

3GPP2 X.S0054-000-0

Version 1.0

Date: December 19, 2007



3RD GENERATION
PARTNERSHIP
PROJECT 2
"3GPP2"

CAN Wireless IP Network Overview and List of Parts

COPYRIGHT

3GPP2 and its Organizational Partners claim copyright in this document and individual Organizational Partners may copyright and issue documents or standards publications in individual Organizational Partner's name based on this document. Requests for reproduction of this document should be directed to the 3GPP2 Secretariat at secretariat@3gpp2.org. Requests to reproduce individual Organizational Partner's documents should be directed to that Organizational Partner. See www.3gpp2.org for more information.

This page is left blank intentionally.

CAN Wireless IP Network Overview and List of Parts

CONTENTS

1
2
3
4
5
6
7
8
9
10
11
12
13
14
15
16
17
18
19
20
21
22
23
24
25
26
27
28
29
30
31
32
33
34
35
36
37
38
39
40
41
42
43
44
45
46
47
48
49
50
51
52
53
54
55
56
57
58
59
60

- 1 Introduction 1
 - 1.1 Scope..... 1
- 2 References 2
 - 2.1 Normative References..... 2
 - 2.2 Informative References 3
- 3 Definitions, Symbols and Abbreviations..... 4
 - 3.1 Definitions 4
 - 3.1.1 Symbols and Abbreviations..... 5
- 4 List of Parts 7
- 5 Network Reference Model 8
 - 5.1 Network Architecture..... 8
 - 5.1.1 Non-Roaming Architecture 9
 - 5.1.2 Roaming Architecture..... 11
 - 5.2 Network Entities 13
 - 5.3 Reference Points 16

LIST OF FIGURES

<i>Figure 1</i>	Non-Roaming Architecture 1 (Split AGW)	9
<i>Figure 2</i>	Non-Roaming Architecture 2 (Single AGW)	10
<i>Figure 3</i>	Roaming Architecture 1 (Split AGW)	11
<i>Figure 4</i>	Roaming Architecture 2 (Single AGW).....	12

1
2
3
4
5
6
7
8
9
10
11
12
13
14
15
16
17
18
19
20
21
22
23
24
25
26
27
28
29
30
31
32
33
34
35
36
37
38
39
40
41
42
43
44
45
46
47
48
49
50
51
52
53
54
55
56
57
58
59
60

LIST OF TABLES

1
2
3
4
5
6
7
8
9
10
11
12
13
14
15
16
17
18
19
20
21
22
23
24
25
26
27
28
29
30
31
32
33
34
35
36
37
38
39
40
41
42
43
44
45
46
47
48
49
50
51
52
53
54
55
56
57
58
59
60

Table 1 List of Parts.....7

REVISION HISTORY

Revision	Date	Remarks
0	December 2007	Initial Release

This document is subject to change.

1
2
3
4
5
6
7
8
9
10
11
12
13
14
15
16
17
18
19
20
21
22
23
24
25
26
27
28
29
30
31
32
33
34
35
36
37
38
39
40
41
42
43
44
45
46
47
48
49
50
51
52
53
54
55
56
57
58
59
60

FOREWORD

(This foreword is not part of this Standard.)

This document was prepared by 3GPP2 TSG-X.

This document is a new specification.

This document is part of a multi-part document consisting of multiple parts that together describes specifications for Converged Access Network (CAN) IP Network .

This document is subject to change following formal approval. Should this document be modified, it will be re-released with a change of release date and an identifying change in version number as follows:

X.S0054-000-X-n

where:

- X an uppercase numerical or alphabetic character [A, B, C, ...] that represents the revision level.
- n a numeric string [1, 2, 3, ...] that indicates a point release level.

This document uses the following conventions:

- “Shall” and “shall not” identify requirements to be followed strictly to conform to this document and from which no deviation is permitted.
- “Should” and “should not” indicate that one of several possibilities is recommended as particularly suitable, without mentioning or excluding others, that a certain course of action is preferred but not necessarily required, or that (in the negative form) a certain possibility or course of action is discouraged but not prohibited.
- “May” and “need not” indicate a course of action permissible within the limits of the document.
- “Can” and “cannot” are used for statements of possibility and capability, whether material, physical or causal.

This page is left blank intentionally.

1 Introduction

This document provides an overview of the series of documents used to specify the Converged Access Network (CAN). The CAN enables optimization and upgrade for packet data access network to support services to the customers. This document also describes the CAN Network Reference Model.

1.1 Scope

This series of documents defines an architecture model and set of specifications for a Converged Access Network (CAN) that can support real time services such as VoIP, Video Telephony, voice and video streaming, etc. The proposed architecture supports multiple access technologies including the Ultra Mobile Braodband™ (UMB™)¹ air interface [12]. This revision of the CAN series of documents provides the following capability:

- Support for UMB air interface only.
- Support for simple IPv4, simple IPv6 [13], Client Mobile IPv4 (CMIP4), and Proxy Mobile IPv4 (PMIP4). RADIUS authentication and authorization support for these protocols is specified. Diameter authentication and authorization support for simple IPv4 and simple IPv6 is specified.
- Support for QoS without SBBC is specified.
- RADIUS-based accounting is specified.

¹ Ultra Mobile Broadband™ and (UMB™) are trade and service marks owned by the CDMA Development Group (CDG).

2 References

2.1 Normative References

This section provides references to other specifications and standards that are necessary to implement this document.

- [1] 3GPP2: X.S0054-100-0 v1.0, “Basic IP Services for Converged Access Network Specifications”, December 2007.
- [2] 3GPP2: X.S0054-102-0 v1.0, “Multiple-Authentication and Legacy Authentication Support for Converged Access Network”, December 2007.
- [3] 3GPP2: X.S0054-110-0 v1.0, “MIPv4 Specification in Converged Access Network”, December 2007.
- [4] 3GPP2: X.S0054-210-0 v1.0, “CMIP Based Inter-AGW Handoff”, December 2007.
- [5] 3GPP2: X.S0054-220-0 v1.0, “Network PMIP Support”, December 2007
- [6] 3GPP2: X.S0054-300-0 v1.0, “QoS Support for Converged Access Network Specification”, December 2007.
- [7] 3GPP2: X.S0054-400-0 v1.0, “Converged Access Network Accounting Specification”, December 2007.
- [8] 3GPP2: X.S0054-910-0 v1.0, “CAN Data Dictionary”, December 2007.
- [9] IETF: draft-leung-mip4-proxy-mode-04.

[Editor’s Note: The above document is a work in progress and should not be referenced unless and until it is approved and published. Until such time as this Editor’s Note is removed, the inclusion of the above document is for informational purposes only.]

- [10] IETF: draft-ietf-netlmm-proxymip6-07

[Editor’s Note: The above document is a work in progress and should not be referenced unless and until it is approved and published. Until such time as this Editor’s Note is removed, the inclusion of the above document is for informational purposes only.]

- [11] 3GPP2: X.S0011-(all parts)-D v1.0, “cdma2000 wireless IP Network Standard”, March 2006.
- [12] 3GPP2: C.S0084-(all parts)-0 v2.0, “Ultra Mobile Broadband (UMB) Air Interface Specification”, September 2007.
- [13] IETF: RFC 3775, “Mobility Support in IPv6”, June 2004.
- [14] 3GPP2: A.S0020-0 v1.0, “Interoperability Specification (IOS) for Ultra Mobile Broadband (UMB) Radio Access Network Interfaces”, November 2007.
- [15] 3GPP2: A.S0008-C v1.0, “Interoperability Specification (IOS) for High Rate Packet Data (HRPD) Radio Access Network Interfaces with Session Control in the Access Network,” July 2007.

- 1
2 [16] 3GPP2: A.S0009-C v1.0, “Interoperability Specification (IOS) for High
3 Rate Packet Data (HRPD) Radio Access Network Interfaces with Session
4 Control in the Packet Control Function,” July 2007.
5
6

7 2.2 Informative References

9 This section provides references to other documents that may be useful for the reader of this
10 document.
11

- 12 <1> 3GPP2: X.S0013-013-0 v1.0, “Service Based Bearer Control – Stage 2”,
13 TBD.
14

15 [Editor's Note: The above document is a work in progress and should not be referenced unless and until it is
16 approved and published. Until such time as this Editor's Note is removed, the inclusion of the above
17 document is for informational purposes only.]
18
19
20
21
22
23
24
25
26
27
28
29
30
31
32
33
34
35
36
37
38
39
40
41
42
43
44
45
46
47
48
49
50
51
52
53
54
55
56
57
58
59
60

3 Definitions, Symbols and Abbreviations

This section contains definitions, symbols and abbreviations that are used throughout the document.

3.1 Definitions

Access Network Route Instance

An Access Network Route Instance (ANRI) is a logical function that has an open route with an AT. An eBS and an SRNC may support an ANRI function. An ANRI is referred to as an Access Network (AN) in [12].

Client Mobile IP

Client Mobile IP refers to use of Mobile IPv4/IPv6 for mobility from the AT. Specifically, the term is used if it is the AT to perform MIP registration with the network. This term is introduced to distinguish from the Proxy MIP where the network entity performs MIP registration on behalf of the AT.

Data Attachment Point

The Data Attachment Point (DAP) is the eBS that receives forward-link user traffic for the AT from the Access Gateway (AGW). The term of DAP in this document is same as DAP eBS in [14].

IP-Session

An IP-Session is a session that is defined by a user's NAI, AAA-Session-ID, and an AT's IP-Address (e.g., IPv4 address, MIPv4 HoA in FA CoA mode, or IPv6 address).

Proxy Mobile IP

Proxy Mobile IP refers to a protocol based on having the Mobile IP client function in a network element to provide mobility support for an unaltered and mobility-unaware device.

Route Set

The set of all ANRIs that have a route with the AT. The Session Anchor ANRI is in the SRNC and is always in the Route Set.

3.1.1 Symbols and Abbreviations

1
2
3
4
5
6
7
8
9
10
11
12
13
14
15
16
17
18
19
20
21
22
23
24
25
26
27
28
29
30
31
32
33
34
35
36
37
38
39
40
41
42
43
44
45
46
47
48
49
50
51
52
53
54
55
56
57
58
59
60

AAA:	Authentication, Authorization, and Accounting
ADP:	Airlink Datagram Protocol
AGW:	Access GateWay
AKA:	Authentication and Key Agreement
AN:	Access Network
ANID:	Access Network Identifier
ANRI:	Access Network Route Instance
AT:	Access Terminal
AVP:	Attribute Vector Pair
BA:	Binding Acknowledgement
BAAA:	Broker AAA
BCE:	Binding Cache Entry
BU:	Binding Update
BS:	Base Station
CAN:	Converged Access Network
CMIP:	Client MIP
CMIP4:	Client MIP version 4
CMIP6:	Client MIP version 6
CN:	Correspondent Node
CoA:	Care-of Address
COA:	Change of Authorization
CVSE:	Critical Vendor/Organization Specific Extension
DAD:	Duplicate Address Detection
DAP:	Data Attachment Point
DHCP:	Dynamic Host Configuration Protocol
DNS:	Domain Name System
DSCP:	Differentiated Service Code Point
DSRK:	Domain Specific Root Key
EAP:	Extensible Authentication Protocol
FLSE:	Forward-Link Serving eBS
FQDN:	Fully Qualified Domain Name
eBS:	evolved Based Station
EMSK:	Extended MSK
ERP:	EAP Reauthentication Protocol
FA:	Foreign Agent
GRE:	Generic Routing Encapsulation
HA:	Home Agent
HAAA:	Home AAA
HoA:	Home Address
HRPD:	High Rate Packet Data
IETF:	Internet Engineering Task Force
IK:	Integrity Key
IKE:	Internet Key Exchange
IMSI :	International Mobile Subscriber Identity
IP:	Internet Protocol
IPv4:	Internet Protocol version 4

IPv6:	Internet Protocol version 6	1
IPsec:	IP Security	2
ISP:	Internet Service Provider	3
LMA:	Local Mobility Agent	4
MEID:	Mobile Equipment Identifier	5
MIN:	Mobile Identification Number	6
MIP:	Mobile IP	7
MIP4:	Mobile IPv4	8
MIP6:	Mobile IPv6	9
MN:	Mobile Node	10
MPA:	Mobility Proxy Agent	11
MSA:	Mobility Security Association	12
MSK:	Master Session Key	13
MSID:	Mobile Station ID	14
NAS:	Network Access Server	15
NAI:	Network Access Identifier	16
NVSE:	Normal Vendor/Organization Specific Extension	17
PCEF:	Policy And Charging Enforcement Function	18
PCRF:	Policy and Charging Rules Function	19
PDSN:	Packet Data Serving Node	20
PMA:	Proxy Mobility Agent	21
PMIP:	Proxy Mobile IP	22
PMIP4:	Proxy Mobile IP Version 4	23
PMIP6:	Proxy Mobile IP Version 6	24
QoS:	Quality of Services	25
RA:	Router Advertisement	26
RADIUS:	Remote Authentication Dial in User Service	27
RAN:	Radio Access Network	28
RLSE:	Reverse-Link Serving eBS	29
RO:	Route Optimization	30
RRQ:	Registration Request	31
RRP:	Registration Reply	32
RS :	Router Solicitation	33
SPI:	Security Parameter Index	34
SRNC:	Session Reference Network Controller	35
UDP:	User Datagram Protocol	36
UDR:	Usage Data Record	37
UMB:	Ultra Mobile Broadband	38
VAAA:	Visited AAA	39
VoIP:	Voice over IP	40
		41
		42
		43
		44
		45
		46
		47
		48
		49
		50
		51
		52
		53
		54
		55
		56
		57
		58
		59
		60

4 List of Parts

The parts that comprise the initial release of this document are shown in Table 1. Each document in the series is numbered as a Part that is placed into a Group. Each Group of parts represents an area of focus within the series of documents.

Table 1 List of Parts

Group	Part	Title
-000		CAN Wireless IP Network Overview and List of Parts
	-000	CAN Wireless IP Network Overview and List of Parts
-100		CAN Wireless IP Network Basic Operations
	-100	Basic IP Services for Converged Access Network Specifications [1]
	-102	Multiple-Authentication and Legacy Authentication Support for Converged Access Network[2]
	-110	MIPv4 Specification in Converged Access Network [3]
-200		CAN Mobility Management
	-210	CMIP Based Inter-AGW Handoff [4]
	-220	Network PMIP Support [5]
-300		CAN QoS and SBBC Support
	-300	QoS Support for Converged Access Network Specifications[6]
-400		CAN Accounting
	-400	Converged Access Network Accounting Specification[7]
-500		CAN Network Applications
-600		Interworking
-900		Data Dictionaries
	-910	CAN Data Dictionary [8]

5 Network Reference Model

5.1 Network Architecture

This document defines architecture reference models for roaming and non-roaming scenarios. These architectures take into account the following considerations for mobility management across different network elements.

- Mobility between two administrative domains or between 3GPP2 and non-3GPP2 access technologies (within the same or different administrative domains) is defined as Inter Domain Mobility.
- Inter-gateway mobility within the same administrative domain is defined as Intra Domain Mobility which is handoff between the Access Gateways under the same technology.
- Both Inter Domain Mobility management and Intra Domain Mobility utilize proxy Mobile IP (PMIP) [9] [10] or client Mobile IP (CMIP) [13].

The data forwarding and context transfer between AGWs, if required for gateway mobility, use an inter-AGW interface. MAG, LMA and PMA are defined in [9], [10]. See section 5.2 for details.

5.1.1 Non-Roaming Architecture

Figure 1 and Figure 2 show the non-roaming architecture models. In Figure 1, U1 provides the mobility between the eBSs and the srv-AGW. U15' provides the mobility between the srv-AGW and the anc-AGW and U16 provides the mobility between the anc-AGW and the LMA/HA. On the other hand, in Figure 2, only one AGW is used for network attachment. U1 provides the mobility between the eBSs and the AGW, U28 provides the mobility between the AGWs, and U26/U27 provide the mobility between AGW and LMA/HA.

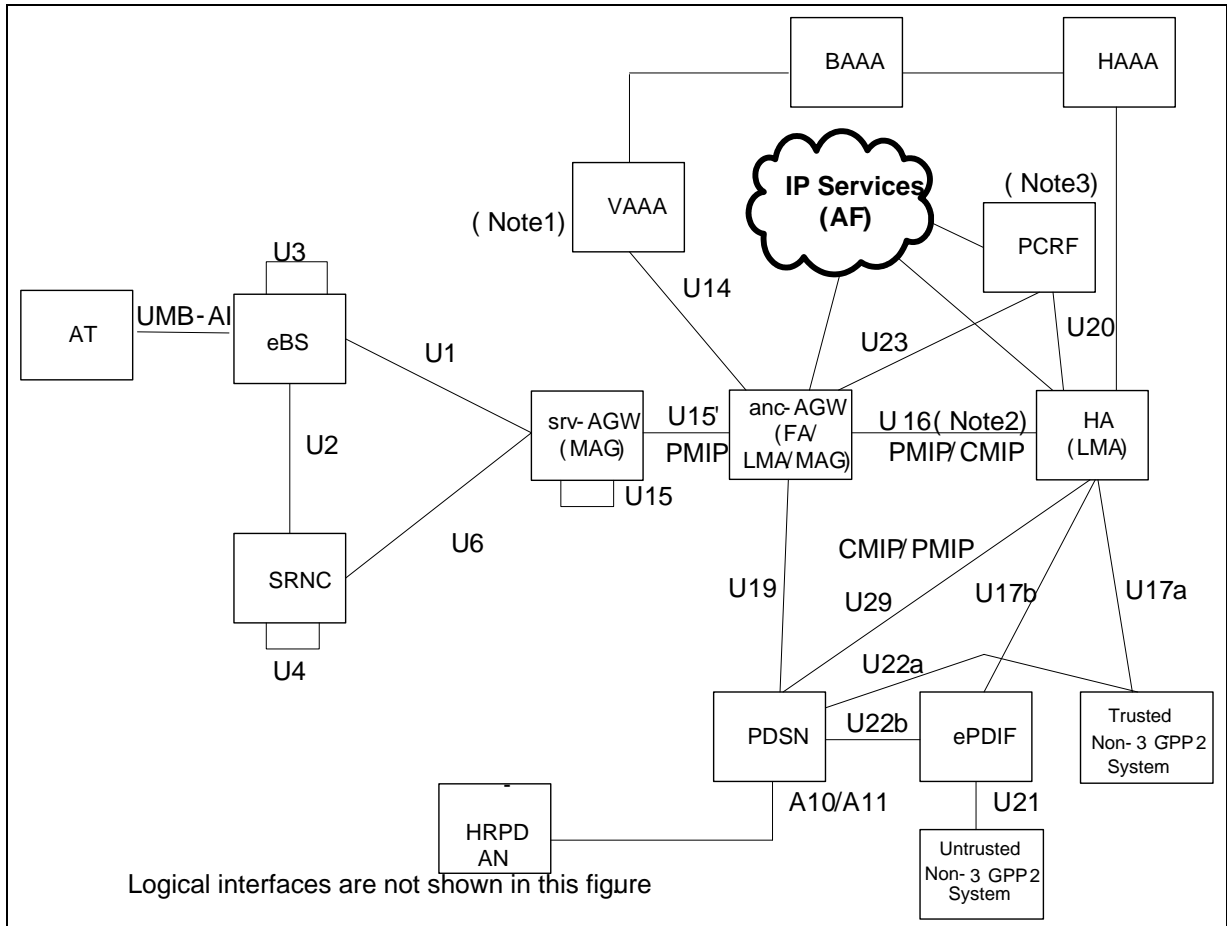

Figure 1 Non-Roaming Architecture 1 (Split AGW)

Note 1 – The access authentication transaction is initiated by the SRNC and is routed via the anc-AGW to the VAAA. That is, there exists a logical interface between the SRNC and the VAAA.

Note 2 – The U16 interface is used for inter-domain or intra-domain mobility, which is either based on PMIP or CMIP.

Note 3 - For policy control, the Application Function (AF) in the IP services network (as shown in the figure) interacts with the Policy and Charging Rules Function (PCRF) and the PCRF directly or indirectly interacts with the Policy and Charging Enforcement Function (PCEF) as instructed by the AF. The PCEF resides in all bearer nodes (i.e., HA, LMA, srv-AGW, anc-AGW, eBS) and performs the following functions:

5.1.2 Roaming Architecture

The Roaming architectures of Figure 3 and Figure 4 support the visited services scenario and bearer traffic local breakout for the home services scenario.

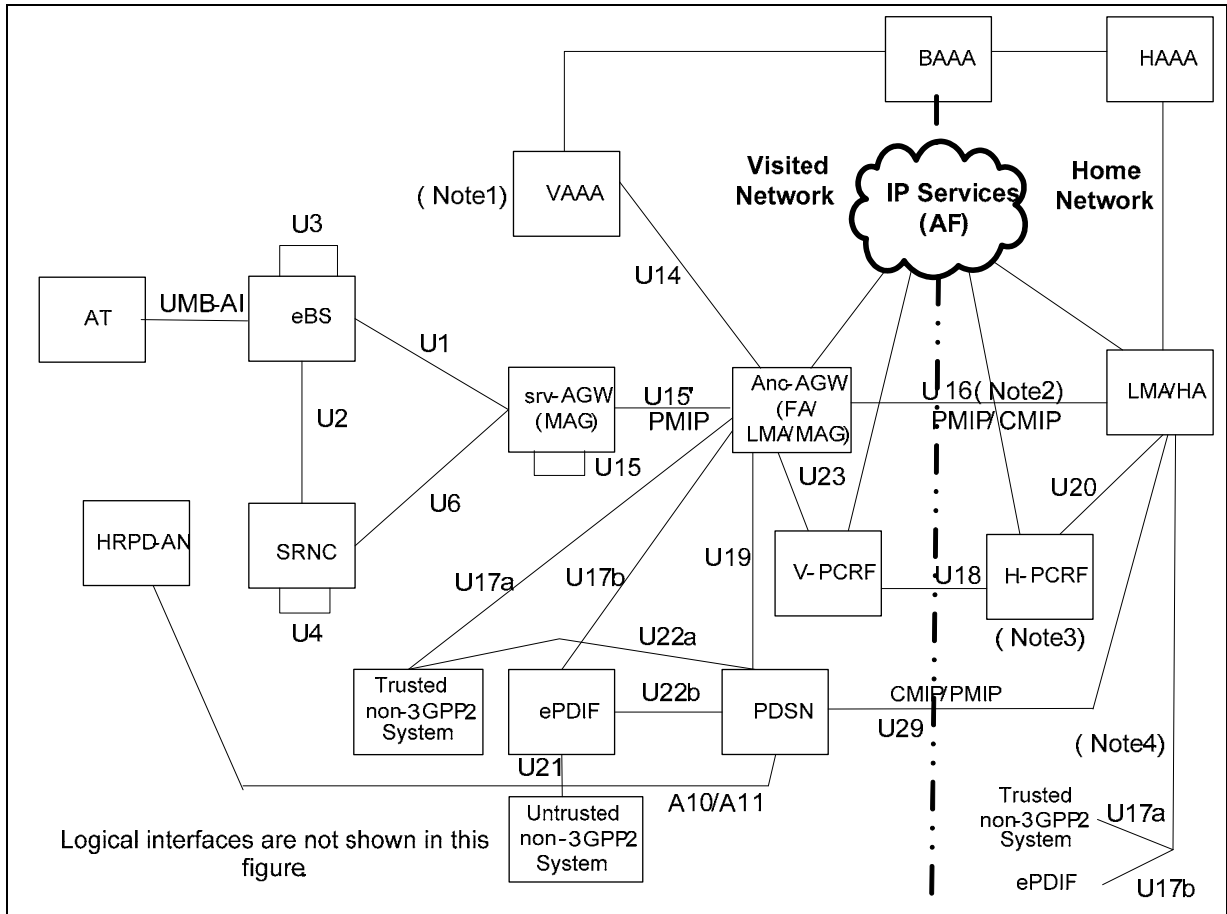

Figure 3 Roaming Architecture 1 (Split AGW)

Note 1 – The access authentication transaction is initiated by the SRNC and is routed via the anc-AGW to the VAAA. I.e., there exists a logical interface between the SRNC and the VAAA.

Note 2 – The U16 interface is either based on PMIP or CMIP as in the non-Roaming scenario.

Note 3 – The role of the PCRF and PCEF are the same as those captured above (see Note 3 under Figure 1 in the non-Roaming case).

Note 4 – If the LMA/HA is allocated in the visited network (e.g., via dynamic LMA/HA allocation) then interfaces 17a/b in the home network are not required. In this case, contrary to the figure above these interfaces terminate in the LMA/HA in the visited network.

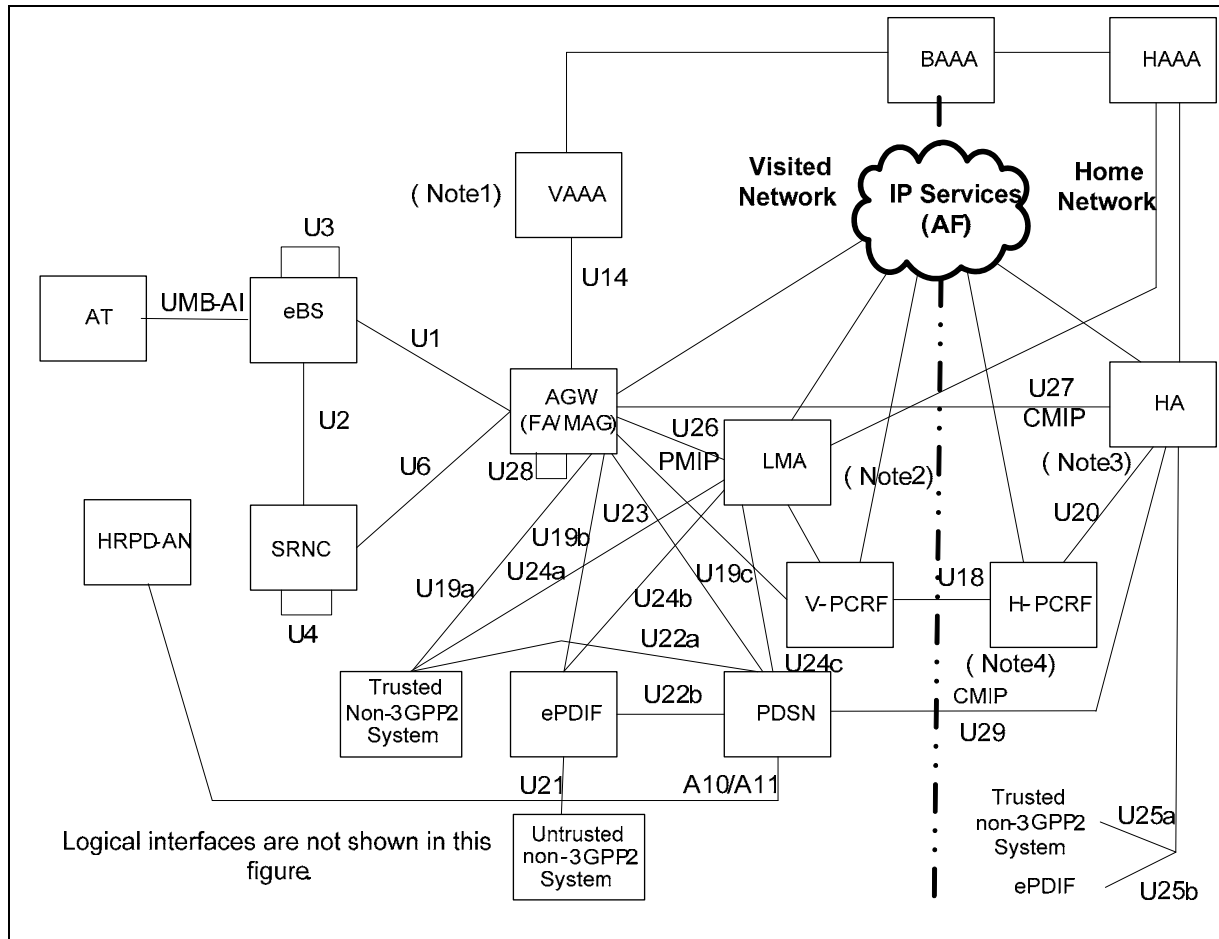

Figure 4 Roaming Architecture 2 (Single AGW)

Note 1 - The access authentication transaction is initiated by the SRNC and is routed via the AGW to the VAAA. That is, there exists a logical interface between the SRNC and the VAAA.

Note 2 - LMA can be located in the home network.

Note 3 - If the HA is allocated in the visited network (via dynamic HA allocation) then interfaces 25a/b in the home network are not required. In this case, contrary to the figure above these interfaces will terminate in the HA in the visited network.

Note 4 - The role of the PCRF and PCEF are the same as those captured above (see Note 2 under Figure 2 in the non-Roaming case).

1
2
3
4
5
6
7
8
9
10
11
12
13
14
15
16
17
18
19
20
21
22
23
24
25
26
27
28
29
30
31
32
33
34
35
36
37
38
39
40
41
42
43
44
45
46
47
48
49
50
51
52
53
54
55
56
57
58
59
60

5.2 Network Entities

A description of each of the network entities are provided below.

Proxy Mobile Agent (PMA) or Mobile Access Gateway (MAG)

Proxy mobile agent (or mobile access gateway) is a function that manages the mobility related signaling for a mobile node that is attached to its access link. It is responsible for tracking the mobile node's attachment to the link and for signaling the mobile node's local mobility anchor. PMA is PMIP4 term and MAG is PMIP6 term.

Local Mobility Anchor (LMA)

Local Mobility Anchor is the home agent for the mobile node in the Proxy Mobile IPv6 domain. It is the topological anchor point for the mobile node's home prefix and is the entity that manages the mobile node's reachability state. The LMA has the functional capabilities of a home agent as defined in Mobile IPv6 base specification [13] and with the additional required capabilities for supporting Proxy Mobile IPv6 as defined in this specification.

AAA

This functional entity provides authentication, authorization, and accounting functions with respect to the AT's use of the network resources. The AAA has roles as a Visited AAA (VAAA), Broker AAA (BAAA), and Home AAA (HAAA).

Home Agent (HA)

Home Agent is used to provide a mobility solution to the AT in a 3GPP2 packet data network. HA is the topological anchor point for the AT's home network and is the entity that manages the AT's reachability state. The home agent intercepts packets destined to the mobile node's home address, encapsulates them, and tunnels them to the mobile node's registered care-of-address. The home agent may also be used for inter-technology mobility. Depending on the architectural configuration, the HA may include the Local Mobility Agent (LMA).

High-Rate Packet Data Access Network (HRPD-AN)

The HRPD-AN is a node in the HRPD legacy packet data network.

ePDIF

The evolved Packet Data Interworking Function (ePDIF) is an Interworking function for connectivity between a 3GPP2 network and an untrusted non-3GPP2 network (for example, WiFi AP.)

IP Services

IP Services comprise any IP based services provided by the operator or 3rd party. This may be part of the Internet or a closed network.

Non-3GPP2

A non-3GPP2 System may be trusted or untrusted. The AT accesses an operator's network via an ePDIF if the access network is untrusted, and the AT accesses an operators network directly (i.e. without an ePDIF) if the access network is trusted.

Access Gateway (AGW)

The Access Gateway (AGW) is an entity that provides the user's "point of IP connectivity" to the network. That is, the AGW is in effect the first-hop router for the mobile terminal. The AGW performs layer 3 services and above, including hot-lining, accounting, policy enforcement, etc. In Split AGW architectures there is a Serving AGW (srv-AGW) and an Anchor AGW (anc-AGW).

Access Terminal (AT)

The access terminal is the subscriber device supported by the network. The UMB air interface requirements for the AT are defined in [12].

Packet Data Serving Node (PDSN)

The PDSN is the node that provides the user's point of IP connectivity in the legacy packet data network. A detailed description of the PDSN functions is provided in [11].

Policy and Charging Rules Function (PCRF)

This term refers to the rules provided by the PCRF to the AGW over the U23 reference point (i.e., Ty). The purpose of the Service Based Bearer Control (SBBC) rule is to:

- a. Detect a packet belonging to a service data flow,
- b. Provide policy control for a service data flow, and to
- c. Provide applicable charging parameters for a service data flow.

For a detailed description of the PCRF functions please refer to [17].

Session Reference Network Controller (SRNC)

The Session Reference Network Controller (SRNC) is responsible for maintaining the session reference with the AT. The SRNC is also responsible for supporting idle state management of the AT, and providing paging control functions when the AT is idle. The SRNC contains a Session Anchor Access Network Route Instance (ANRI) for each AT it is supporting. The requirements for the SRNC are defined in [14].

Evolved Base Station (eBS)

The evolved base station (eBS) provides the over-the-air signaling and user data transport that is used by the AT for connectivity to the radio access network. Refer to [14].

The functions of the eBS include:

- Over-the-air transmission of packets
- Encryption/decryption of packets at the RLP level for over-the-air transmission/reception.
- Scheduling for over-the-air transmission
- Policy enforcement for over-the-air transport.
- Header Compression

1
2 Additionally, although IP and above services are provided in the gateway or above the
3 gateway, the eBS also has visibility to the user's IP packets; at the very least, the base station
4 has visibility to the outermost header that is sent to the mobile terminal. With this IP visibility,
5 the base station can perform optimizations to over-the-air scheduling or other value added
6 functions. In order to perform these optimizations, some policy information may need to be
7 conveyed from the AGW to the eBS.
8
9
10
11
12
13
14
15
16
17
18
19
20
21
22
23
24
25
26
27
28
29
30
31
32
33
34
35
36
37
38
39
40
41
42
43
44
45
46
47
48
49
50
51
52
53
54
55
56
57
58
59
60

5.3 Reference Points

The architecture contains the following reference points:

- U1 The U1 reference point carries control and bearer information between evolved Base Station (eBS) and the Access GateWay (AGW). The U1 reference point includes interfaces for bearer transport (user data and signaling), QoS, and accounting. Refer to [1] [6] [7] [14].
- U2 The U2 reference point provides interfaces for carrying control information between the eBS and the SRNC. Refer to [14].
- U3 The U3 reference point carries control and bearer information between eBSs. Refer to [14].
- U4 The U4 reference point carries control information between SRNCs. Refer to [14].
- U6 The U6 reference point connects the SRNC to the AGW. See also [14].
- U14 The U14 reference point connects the anc-AGW or AGW with the AAA infrastructure via the Visited AAA server (VAAA). This reference point implements a signaling protocol to support user authentication, authorization and accounting..
- U15 The U15 reference point carries control and bearer information between srv-AGW. U15 reference point provides local mobility based on PMIP
- U15' The U15' reference point carries control and bearer information between two AGWs: the Serving AGW (srv-AGW) and the Anchor AGW (anc-AGW). This reference point is not exposed if the srv-AGW and anc-AGW are collocated. This reference point also carries policy information. The anc_AGW acts a proxy between the PCRF and the srv-AGW.
- U16 The U16 reference point carries control and bearer information between the AGW and the Home Agent (HA), and supports bearer transport and signaling for mobility as well.
- U17 The U17 reference point carries control and bearer information between the 3GPP2 network and a non-3GPP2 network. The U17a reference point carries control and bearer information between the 3GPP2 network and a trusted non-3GPP2 network (e.g., 3GPP SAE/LTE or WiMAX). The U17b reference point carries control and bearer information between the 3GPP2 network and a untrusted non-3GPP2 network via the ePDIF (e.g., a WiFi network).
- U18 The U18 reference point carries control information between a Visited PCRF (V-PCRF) and a Home PCRF (H-PCRF) in order to transfer policy and charging rules between domains.
- U19 The U19 reference point carries control and bearer (optional) information between the AGW and the trusted non-3GPP2 System (U19a), and between the AGW and the ePDIF (U19b), and between the anc-AGW/AGW and the PDSN (U19/U19c). The

- 1
2
3
4
5
6
7
8
9
10
11
12
13
14
15
16
17
18
19
20
21
22
23
24
25
26
27
28
29
30
31
32
33
34
35
36
37
38
39
40
41
42
43
44
45
46
47
48
49
50
51
52
53
54
55
56
57
58
59
60
- U19 reference point supports fast/seamless handoff between a CAN and another system.
- U20 The U20 reference point connects the HA and the PCRF, and allows (QoS) policy and charging information to be conveyed to the HA.
- U21 The U21 reference point connects the ePDIF to an untrusted non-3GPP2 access network.
- U22 The U22 reference point provides two separate interfaces: U22a and U22b. The U22a reference point connects the PDSN to a trusted non-3GPP2 network. For this connection the ePDIF is not required to be on the data path. The U22b reference point, however, carries control and bearer information between the PDSN and an untrusted non-3GPP2 network. For this connection the ePDIF is required to be on the data path.
- UMB-AI The UMB air interface [12] carries control and bearer information between the AT and the eBS.
- U23 The U23 reference point carries control information from the (QoS) Policy and Charging Rules Function (PCRF) to the anc-AGW/AGW. The U23 reference point is the same as the Ty reference point described in [17].
- U24 The U24 reference point carries control and bearer information between an LMA and another system. The U24 reference point carries control and bearer information with PMIP between the LMA and the trusted non-3GPP2 System (U24a), and between the LMA and the ePDIF (U24b), and between the LMA and the PDSN (U24c). The U24 reference point supports handoff between a CAN and another system.
- U25 The U25 reference point carries control and bearer information with CMIP between the HA and the trusted non-3GPP2 System (U25a), and between the HA and the ePDIF (U25b). The U25 reference point supports handoff between a CAN and another system.
- U26 The U26 reference point carries control and bearer information with PMIP between the LMA and the AGW and supports handoff between AGWs.
- U27 The U27 reference point carries control and bearer information with CMIP between the HA and the AGW and supports handoff between AGWs.
- U28 The U28 reference point carries control and bearer (optional) information between the AGWs and supports fast inter-AGW handoff.
- U29 The U29 reference point carries control and bearer information between the HA and the PDSN. The U29 reference point carries CMIP and PMIP for the split AGW architectures. The U29 reference point carries CMIP for the single AGW architecture.
- A10/11 The A10/A11 reference point carries control (A11) and bearer (A10) information between the PDSN and HRPD AN. See [15] and [16] for details.