

1 3GPP2 X.S0013-007-0

2 *Version 1.0*

3 *Date: December 2003*



3RD GENERATION
PARTNERSHIP
PROJECT 2
"3GPP2"

4

5

6

7 ***All-IP Core Network Multimedia Domain***

8

9 *IP Multimedia Subsystem - Charging Architecture*

10

11

12

13

14

15

16

17

18

COPYRIGHT NOTICE

3GPP2 and its Organizational Partners claim copyright in this document and individual Organizational Partners may copyright and issue documents or standards publications in individual Organizational Partner's name based on this document. Requests for reproduction of this document should be directed to the 3GPP2 Secretariat at secretariat@3gpp2.org. Requests to reproduce individual Organizational Partner's documents should be directed to that Organizational Partner. See www.3gpp2.org for more information.

19

20

All-IP Core Network Multimedia Domain
IP Multimedia Subsystem - Charging Architecture

Contents

6	FOREWORD	V
7	REVISION HISTORY	V
8	1 SCOPE	1
9	2 REFERENCES	1
10	3 DEFINITIONS, ABBREVIATIONS AND SYMBOLS	1
11	3.1 Definitions	1
12	3.2 Abbreviations	2
13	3.3 Symbols	2
14	4 ARCHITECTURE	3
15	4.1 Charging Mechanisms	3
16	4.1.1 Off-line Charging	3
17	4.1.2 On-line Charging	3
18	4.2 Logical Network and Charging Architecture	3
19	4.2.1 IMS Architecture	3
20	4.2.1.1 Architecture reference model for off-line charging	3
21	4.2.1.2 Architecture reference model for on-line charging	5
22	4.3 Charging Functions	7
23	4.3.1 AAA	7
24	4.3.2 Session Charging Function (SCF)	7
25	4.3.3 Bearer Charging Function (BCF)	7
26	4.3.4 Event Charging Function (ECF)	7
27	4.3.4.1 Subscriber Content Charging Function (SCCF)	8
28	4.3.4.2 Content Provider Charging Function (CPCF)	8
29	4.4 Charging Principles	9
30	4.4.1 Correlation of Charging Information	9
31	4.4.1.1 Charging Correlation Levels	9
32	4.4.1.2 Charging Correlation Capabilities	9
33	4.5 Implementation of Offline and Online Charging	10
34	4.5.1 On-line charging reference point IMS Network Entity - ECF (Ro)	10

1	4.5.2	Usage of Rf and Ro Interfaces.....	10
2	4.5.3	Usage of Rf and ISC Interfaces	10
3			
4			
5			
6			

1 **Foreword**

2 “This document contains portions of material copied from 3GPP document number(s) TS 32.200. The
 3 copyright on the 3GPP document is owned by the Organizational Partners of 3GPP (ARIB - Association of
 4 Radio Industries and Businesses, Japan; CWTS – China Wireless Telecommunications Standards group,
 5 China; ETSI – European Telecommunications Standards Institute; ATIS, USA; TTA - Telecommunications
 6 Technology Association, Korea; and TTC – Telecommunication Technology Committee, Japan), which
 7 have granted license for reproduction and for use by 3GPP2 and its Organizational Partners.”

8

9 **Revision History**

10

<i>REVISION HISTORY</i>		
<i>Revision number</i>	<i>Content changes.</i>	<i>Date</i>
0	Initial Publication	December 2003

11

12

1 Scope

The present document describes the architecture for charging and billing for IMS services.

For the purpose of the present document, the charging data is considered to be generated and collected by charging functions in the network elements.

The objectives of the present document are:

- to describe principles of charging in an IMS network;
- to provide a description of the charging architecture; and
- to provide the descriptions of events and triggers for the generation of charging data.

2 References

The following documents contain provisions which, through reference in this text, constitute provisions of the present document.

- References are either specific (identified by date of publication, edition number, version number, etc.) or non-specific.
- For a specific reference, subsequent revisions do not apply.

For a non-specific reference, the latest version applies

[1] 3GPP2 X.S0013-008: "IP Multimedia Subsystem; Accounting Information Flows and Protocol"

TIA-873-008: "IP Multimedia Subsystem; Accounting Information Flows and Protocol"

[2] 3GPP2 X.S0013-000: "All-IP Core Network Multimedia Domain; Overview"

TIA-873-000: "All-IP Core Network Multimedia Domain; Overview"

3 Definitions, abbreviations and symbols

3.1 Definitions

For the purposes of the present document, the following apply:

accounting: process of apportioning charges between the Home Environment, Serving Network and User.

accounting information record: record generated by a network element for the purpose of passing relevant data or information to a centralized accounting function.

advice of charge: real-time display of the network utilization charges incurred by the Mobile Station. The charges are displayed in the form of charging units. If a unit price is stored by the MS then the display may also include the equivalent charge in the home currency.

billing: function whereby records generated by the charging function are transformed into bills requiring payment.

chargeable event: activity utilizing telecommunications network infrastructure and related services for user to user communication (e.g. a single call, a data communication session or a short message), or for user to network communication (e.g. service profile administration), or for inter-network communication (e.g. transferring calls, signalling, or short messages), or for mobility (e.g. roaming or inter-system handover), which the network operator wants to charge for.

charged party: user involved in a chargeable event who has to pay parts or the whole charges of the

1 chargeable event, or a third party paying the charges caused by one or all users involved in the chargeable
2 event, or a network operator.

3 **charging:** function whereby information related to a chargeable event is formatted and transferred in order
4 to make it possible to determine usage for which the charged party may be billed.

5 **charging data:** data generated by a network element for the purpose of billing a subscriber for the provided
6 service. It includes data identifying the user, the session and the network elements as well as information
7 on the network resources and services used to support a subscriber session.

8 **near real time:** near real time charging and billing information is to be generated, processed, and
9 transported to a desired conclusion in less than 1 minute.

10 **rating:** The act of determining the cost of the service event.

11 **real time:** real time charging and billing information is to be generated, processed, and transported to a
12 desired conclusion in less than 1 second.

13 **settlement:** payment of amounts resulting from the accounting process.

14 **3.2 Abbreviations**

15 For the purposes of the present document, the following abbreviations apply:

16	3G	3 rd Generation
17	AAA	Authentication, Authorization, and Accounting
18	AS	Application Server
19	BCF	Bearer Charging Function
20	BGCF	Breakout Gateway Control Function
21	BS	Billing System
22	CPCF	Content Provider Charging Function
23	CSCF	Call Session Control Function
24	ECF	Event Charging Function
25	ICID	IMS Charging ID
26	ICN	IP Connectivity Network
27	I-CSCF	Interrogating CSCF
28	IMS	IP Multimedia Subsystem
29	IP	Internet Protocol
30	MGCF	Media Gateway Control Function
31	MRFC	Media Resource Function Controller
32	MS	Mobile Station
33	OCS	Online Charging System
34	P-CSCF	Proxy CSCF
35	PDF	Policy Decision Function
36	PDSN	Packet Data Serving Node
37	PLMN	Public Land Mobile Network
38	SCCF	Subscriber Content Charging Function
39	SCF	Session Charging Function
40	S-CSCF	Serving CSCF
41	SDP	Session Description Protocol
42	SGW	Signaling Gateway
43	SIP	Session Initiation Protocol
44	TCID	Transport Charging ID
45	UE	User Equipment

46 **3.3 Symbols**

47 For the purposes of the present document the following symbols apply:

48	Rb	Online Charging Reference Point between Session Charging Function and Correlation 49 Function
----	----	--

1	Rc	Online Charging Reference Point between ECF and Correlation Function
2	Re	Online Charging Reference Point towards a Rating Server
3	Rf	Offline Charging Reference Point between an IMS Network Entity or an AS and AAA
4	Ro	Online Charging Reference Point between an AS or MRFC and the ECF

5 **4 Architecture**

6 **4.1 Charging Mechanisms**

7 The charging functionality is based on the IMS network nodes reporting accounting information upon
 8 reception of various SIP methods or ISUP messages, as most of the accounting relevant information is
 9 contained in these messages. This reporting is achieved by sending Diameter *Accounting Requests (ACR)*
 10 [Start, Interim, Stop and Event] from the IMS nodes to the AAA and/or ECF.

11 **4.1.1 Off-line Charging**

12 For off-line charging the accounting information is gathered from various IMS network nodes where it may
 13 be held for later forwarding to the Billing System. See Section 4.3.2 for further information.

14 **4.1.2 On-line Charging**

15 On-line charging interacts in real time or near real time with the service being provided by the system. The
 16 subscriber's account is decremented in some units based on current usage of the system. Charging may be
 17 based on events, time, or resource usage.

18 **4.2 Logical Network and Charging Architecture**

19 **4.2.1 IMS Architecture**

20 The overall IMS architecture is described in [2].

21

22

Figure 4.1: Null

23 **4.2.1.1 Architecture reference model for off-line charging**

24 Figure 4.2 presents the off-line IMS charging architecture for non-roaming scenario.

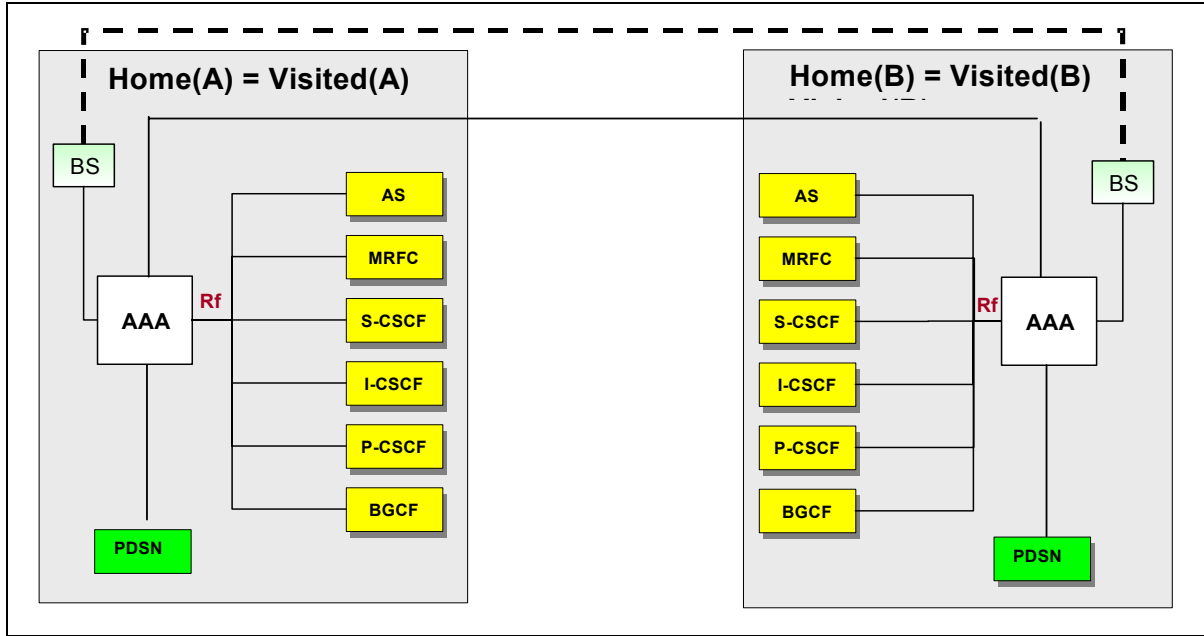

1
2

3

Figure 4.2: Off-line IMS Charging architecture for non-roaming scenario

4

NOTE: The topological merging of some of the lines representing the Rf reference points for connecting with the AAA are performed for figure layout purposes only, and do not imply any other logical or physical association.

5

6

7

The interfaces between the PDSN and AAA and between AAA of User A's Home System and User B's Home System are outside the scope of this specification.

8

9

Figure 4.3 presents the off-line IMS charging architecture for roaming scenario.

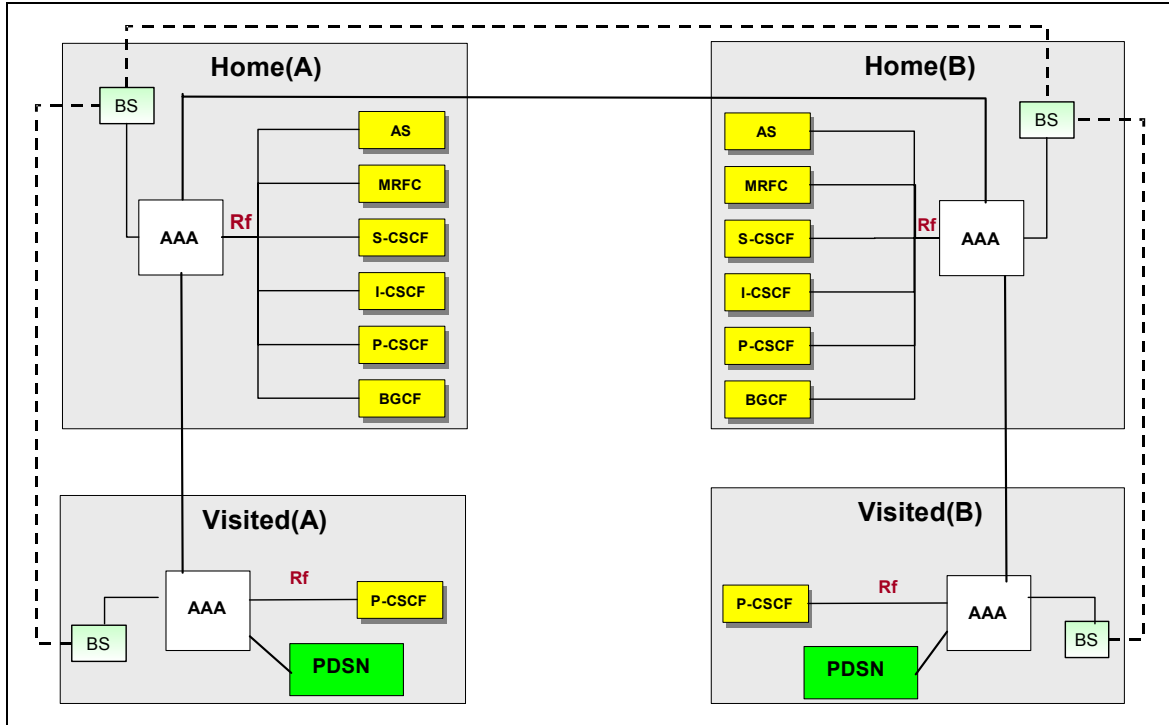

1
2

3

Figure 4.3: Off-line IMS Charging architecture for roaming scenario

4

NOTE 1: The topological merging of some of the lines representing the Rf reference points for connecting with the AAA are performed for figure layout purposes only, and do not imply any other logical or physical association.

6

7

In the off-line charging model operators have traditionally exchanged charging information between billing systems as shown in the figure. Operators may desire to exchange charging information in near real time utilizing the AAA infrastructure. In this case, the AAA in the visited network may pass information to the AAA in the home network. The interface between the PDSN and AAA, those between billing systems and the interfaces between AAA of User A's Home System and User B's Home System are outside the scope of this specification.

10

11

12

13

4.2.1.2 Architecture reference model for on-line charging

14

Figure 4.4 below presents the on-line IMS charging architecture.

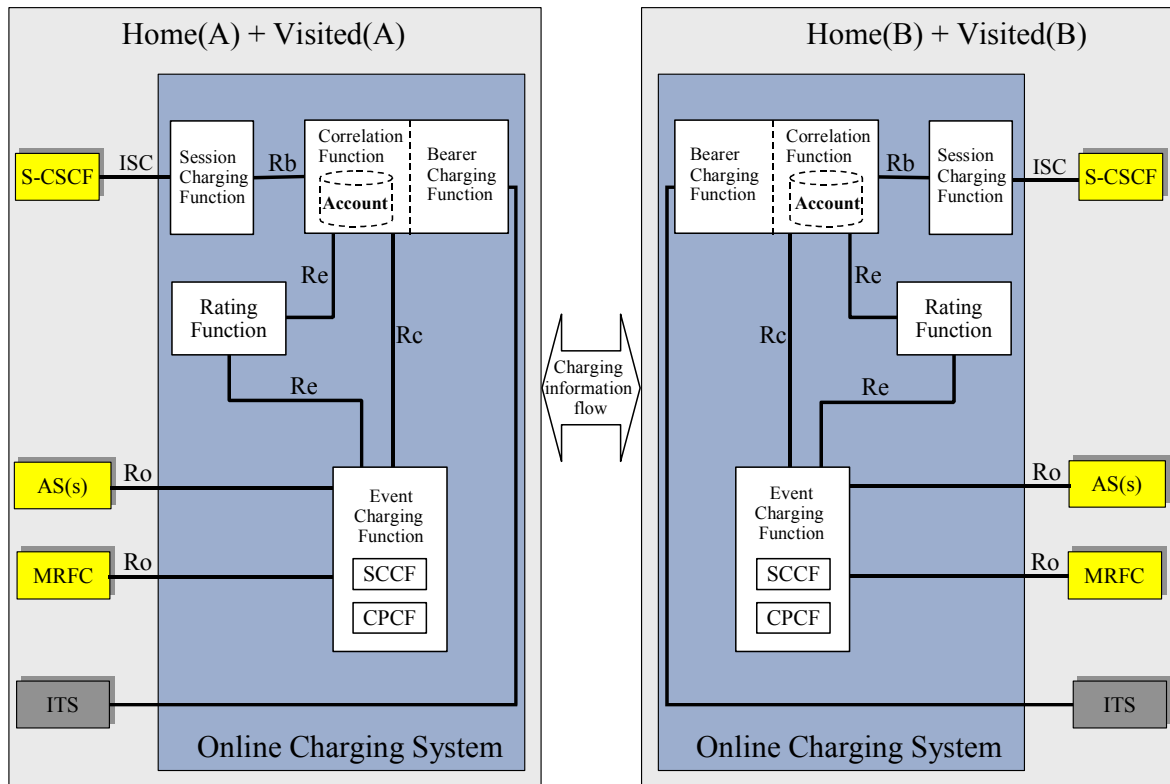

1
2

3 **Figure 4.4: On-line IMS Charging architecture**

4 Access Charging is performed using the appropriate IP Transport Subsystem charging interface to the
5 Bearer Charging Function. This may involve the use of AAA infrastructure to transfer information from the
6 visited network to the home network.

7 Session Charging is performed using the ISC interface between the IMS Session Charging Function and the
8 S-CSCF. Routing to the Session Charging Function is performed as per regular ISC procedures.

9 Event-based charging between an AS or MRFC and the Event Charging Function (ECF) is performed using
10 the Ro reference point. The Ro reference point is described in subclause 4.5.1. ECF address information is
11 distributed using SIP signalling such that Application Servers or MRFCs can use it to find the ECF.

12 Note: It is for further study as to whether the AAA can serve as the Event Charging Function.

13 The Re reference point allows the interaction with a Rating server.

14 The Rc reference point performs the following functions:

- 15 • The Event Charging Function can reach the Session Charging Function or the Bearer Charging
16 Function via the Correlation Function.
- 17 • Correlation
- 18 • Access to the Account of the subscriber.

19 The Rb reference point performs the following functions:

- 20 • . The Session Charging Function can reach the Event Charging Function or the Bearer Charging
21 Function via the Correlation Function.

- 1 • Correlation
- 2 • Access to the Account of the subscriber.

3 The SCCF and the CPCF, which are described in sub-clauses 4.3.4.1 and 4.3.4.2, constitute the ECF.

4 **4.3 Charging Functions**

5 **4.3.1 AAA**

6 The AAA main functionalities for IMS are that it provides the mechanism to transfer charging information
7 from the IMS nodes to the network operator's chosen Billing Systems(s). The main functions of the AAA
8 are:

- 9 - the collection of Session charging information from the IMS nodes;
- 10 - intermediate data storage buffering;
- 11 - the transfer of the charging data to the billing systems.

12 The AAA acts as storage buffer for near real-time charging data collection. It provides the charging data to
13 the billing system. This specification identifies the external interfaces of the AAA for accounting purposes,
14 but does not specify the internal functionality. However, some of the AAA functionality is described to
15 indicate its behavior. The AAA may perform specific activities, such as consolidation of data, pre-
16 processing of data fields, filtering of un-required data fields, and adding of Operator defined fields for
17 specific billing systems. These specific activities may be performed to optimize the charging information
18 that is to be forwarded to the Billing System, which should reduce the load in the Billing System.

19 The AAA can receive data from the IMS nodes in near real-time mode. It should have enough storage to
20 enable it to transmit the collected charging data to the Billing System in file mode. The AAA may have to
21 support several transmission protocols towards the Billing System, depending on the Billing System(s)
22 used. One of the purposes of the AAA is to reduce the number of different interfaces between the Billing
23 System and the IMS nodes sending charging data. If a new Billing System is introduced it shall be
24 interfaced to the AAA, i.e. the protocol stacks and configurations of the IMS nodes do not need to be
25 updated. The usage and load of mass memory media can be more evenly distributed. The AAA may be
26 distributed to several physical nodes to facilitate redundancy.

27 **4.3.2 Session Charging Function (SCF)**

28 The Session Charging Function is responsible for Session Charging including the session control such as
29 e.g. session termination. Other functions such as the Correlation Function communicate with the Session
30 Charging Function via the Rb reference point.

31 **4.3.3 Bearer Charging Function (BCF)**

32 The Bearer Charging Function performs the Bearer Charging.

33 **4.3.4 Event Charging Function (ECF)**

34 The Event Charging Function (ECF) performs event-based charging (content charging). It makes use of the
35 rating function in order to determine the value of the service rendered. The ECF may correlate several
36 event-based charging requests. The ECF provides information via the Rc reference point that triggers the
37 Correlation Function to debit or credit the subscriber's account. Additional information sent by the ECF
38 may also be used in the Correlation Function to correlate Event Charging with Bearer Charging and
39 Session Charging.

40 This specification addresses the following cases:

- 41 - the subscriber account, the ECF and the AS/MRFC (e.g. content server) are located in the same
42 operator network.

1 - the AS/MRFC are in a different operator network than the ECF and the subscriber account.

2 However, the scenario where each of the content charging functions (SCCF and CPCF) is located in
3 different operator networks, and thus in different ECFs, is not addressed in this specification.

4 *The SCCF and the CPCF, which are described below, constitute the ECF.*

5 **4.3.4.1 Subscriber Content Charging Function (SCCF)**

6 The **Subscriber Content Charging Function (SCCF)** is always located in the same operator network as
7 the account of the subscriber. The SCCF handles content charging requests that are made when the
8 subscriber accesses the content. Upon such a content charging request, the SCCF may for example request
9 the Correlation Function to check or to debit the subscriber's account. Content charging requests are
10 received from the Content Provider Charging Function (CPCF).

11 In particular, the SCCF has the following responsibilities:

- 12 • to handle charging requests from the CPCF;
- 13 • to obtain the identity of the subscriber's account;
- 14 • to initiate a procedure to get a charging confirmation from the subscriber, if such a confirmation is
15 needed;
- 16 • to request to debit or to credit a certain amount from/to the subscriber's.

17 **4.3.4.2 Content Provider Charging Function (CPCF)**

18 The **Content Provider Charging Function (CPCF)** manages the account that is maintained for the
19 content provider. Upon receipt of a charging request from the AS/MRFC, the CPCF processes the request
20 and relays it to the SCCF. The CPCF modifies the account of the content provider accordingly.

21 In particular, the CPCF has the following responsibilities:

- 22 • to handle charging requests from the AS/MRFC.
- 23 • to interact with the SCCF that manages the communication with the subscriber's account. This
24 interaction may include requests to the SCCF to charge or to credit the account of the subscriber.

25 As it is not expected that every content provider has a business relationship with every IMS network
26 operator, the CPCF may be located in the operator network or in another network such as for example a
27 Service Provider network that supports the AS/MRFC. However, the second case (CPCF outside of the
28 IMS network operator domain) is not specified in this specification.

1 **4.4 Charging Principles**

2 **4.4.1 Correlation of Charging Information**

3 **4.4.1.1 Charging Correlation Levels**

4 The following levels of correlation for IMS charging shall be considered:

- 5 **1. Correlation within a session.** A session may comprise a number of media components. The IMS
6 Charging ID may be used to correlate the charging data of the different media components
7 belonging to a session.
- 8 **2. Correlation at media component level.** For a session comprising several media components (such
9 as audio and video), charging data is generated for each media component and needs to be correlated
10 between network elements. For this, a component identifier shall be unique and shall clearly identify
11 to which media component of a session this charging information belongs to. This component
12 identifier is not exchanged between network elements and is based on the ordering of media flows in
13 the SDP. This ordering is the same as the one used in the binding information passed to the IP
14 Connectivity Network.

15 Correlation between the IMS and the ICN shall take into account the above described levels.

16 **4.4.1.2 Charging Correlation Capabilities**

17 To support the correlation of charging information, the following capabilities apply to both offline and
18 online charging:

- 19 1) The correlation of charging information for an IMS session is based on the use of IMS Charging
20 Identifiers (ICIDs).
- 21 2) The first IMS network entity within the SIP signalling path is responsible for assigning an ICID.
22 This ICID is then passed along the whole SIP signalling path in an end-to-end manner. However,
23 this shall not preclude further elements (CSCFs) along the session path generating additional
24 identifiers to be passed along. When the AS is the initiator of the session, the AS is responsible for
25 assigning the ICID.
- 26 3) The ICID is passed to all IMS network entities in the SIP signalling path. This is performed using
27 SIP signalling.
- 28 4) For the charging correlation between the ICN and the IMS, one or more Transport Charging IDs,
29 which identify the channels of the session, may be passed from the ICN to the IMS. More
30 specifically, these identifiers need to be transferred from the PDSN to the P-CSCF via the PDF.
- 31 5) The Transport Charging IDs (TCIDs) are passed by the P-CSCF to the S-CSCF and the AS using
32 SIP signalling. Along with the ICID, the S-CSCF passes the TCIDs to on-line and off-line charging
33 functions. The TCIDs are not transferred from one Home IMS (e.g. of the A-Party) to another Home
34 IMS (e.g. the one of the B-Party).
- 35 6) The ICID applies for the duration of the event with which it is associated. For example, an ICID
36 assigned for registration is valid for all registration-related charging procedures until a de-
37 registration occurs, an ICID assigned for session establishment is valid until session termination, etc.
- 38 7) The charging correlation identifiers (ICIDs, TCIDs) will not be passed to the UE. They may
39 however be passed to a content server connected as an endpoint.

40 The charging correlation principles outlined above are applicable to other types of access networks. For
41 instance, it shall be possible to use instead of "Transport Charging ID" an equivalent term of the associated
42 access network.

1 The detailed effects of certain complex scenarios (e.g. forking, multiparty sessions) to these charging
2 correlation principles are for further study.

3 **4.5 Implementation of Offline and Online Charging**

4 The IMS charging architecture, described in this specification specifies that for offline charging all
5 communications between the IMS network entities and the AAA are carried out on the Rf interface. On the
6 other hand, for online charging the Ro interface is used by the AS and MRFC towards the Event Charging
7 Function and the ISC interface is used between the S-CSCF and the Session Charging Function. The rules
8 governing the selection of the proper interfaces are described in the subclauses below.

9 **4.5.1 On-line charging reference point IMS Network Entity - ECF (Ro)**

10 Event-based charging between an AS or MRFC and the ECF is performed using the Ro reference point. Ro
11 is an open interface which is standardized in [1]. The protocol for the Ro reference point is easily
12 extendable to include additional online charging functions. The Ro reference point supports integrity
13 protection and authentication for the case that the AS is outside the operator domain.

14 **4.5.2 Usage of Rf and Ro Interfaces**

15 The AS and MRFC are able to distinguish whether to apply offline or online charging, i.e. whether to send
16 charging information on the Rf interface to the AAA or on the Ro interface to the ECF (or to use both). The
17 decision of which interface to use is based on the information (AAA and/or ECF address) the AS/MRFC
18 receive in the SIP signaling and the system configuration as provisioned by the operator. If the AS/MRFC
19 only receive the AAA address and do not receive an ECF address then they use only the Rf interface. If
20 only the ECF address was provided then they use only the Ro interface. In cases where both AAA and ECF
21 addresses are provided it is possible to use both interfaces simultaneously.

22 However, operators may overrule the addresses received via the SIP signalling and use their own
23 configured rules instead. Operators may configure locally on the AS/MRFC an ECF and/or AAA address.
24 The AAA address may be locally configured on all other IMS nodes. The choice of whether the IMS nodes
25 use the locally configured addresses or the addresses received by SIP signalling, and the decision on which
26 interface(s) to use, is left for operator configuration.

27 **4.5.3 Usage of Rf and ISC Interfaces**

28 All other IMS nodes (S-CSCF, P-CSCF, I-CSCF, BGCF and MGCF) apply offline charging via the Rf
29 interface using the AAA address as received via SIP signaling or the locally configured AAA address. The
30 S-CSCF supports online charging using the ISC interface, i.e. if the application server addressed over ISC
31 is the Session Charging Function of the OCS.

32