

3GPP2 X.S0004-324-E

v 1.0

Date: January 2007



3RD GENERATION  
PARTNERSHIP  
PROJECT 2  
"3GPP2"

## Mobile Application Part (MAP) -

### VOICE FEATURE SCENARIOS: CALLING NUMBER IDENTIFICATION PRESENTATION, CALLING NUMBER IDENTIFICATION RESTRICTION

#### **COPYRIGHT**

3GPP2 and its Organizational Partners claim copyright in this document and individual OPs may copyright and issue documents or standards publications in individual Organizational Partner's name based on this document. Requests for reproduction of this document should be directed to the 3GPP2 Secretariat at [secretariat@3gpp2.org](mailto:secretariat@3gpp2.org). Requests to reproduce individual Organizational Partner's documents should be directed to that Organizational Partner. See [www.3gpp2.org](http://www.3gpp2.org) for more information.

# REVISION HISTORY

Revision	Date	Remarks
X.S0004-324-E v1.0	January 2007	Initial publication.

1  
2  
3  
4  
5  
6  
7  
8  
9  
10  
11  
12  
13  
14  
15  
16  
17  
18  
19  
20  
21  
22  
23  
24  
25  
26  
27  
28  
29  
30  
31  
32  
33  
34  
35  
36  
37  
38  
39  
40  
41  
42  
43  
44  
45  
46  
47  
48  
49  
50  
51  
52  
53  
54  
55  
56  
57  
58  
59  
60

# 1 INTRODUCTION

Unless otherwise noted, the scenarios in this part depict features operating individually; i.e., feature interactions are not considered unless specifically noted.

The scenarios in this part do not include a complete listing of operation parameters, either in the figures or in the accompanying text descriptions. Parameters are included where they are deemed necessary to improve the understanding of the scenario. For a complete description of the parameters associated with each operation, refer to Parts-540 and -550.

## 2 Calling Number Identification Presentation

This section depicts the communications between network entities in various situations related to automatic roaming and Calling Number Identification Presentation (CNIP). These scenarios are for illustrative purposes only.

### 2.1 CNIP Invocation to an Idle Subscriber

This scenario describes CNIP invocation to an idle, authorized MS.

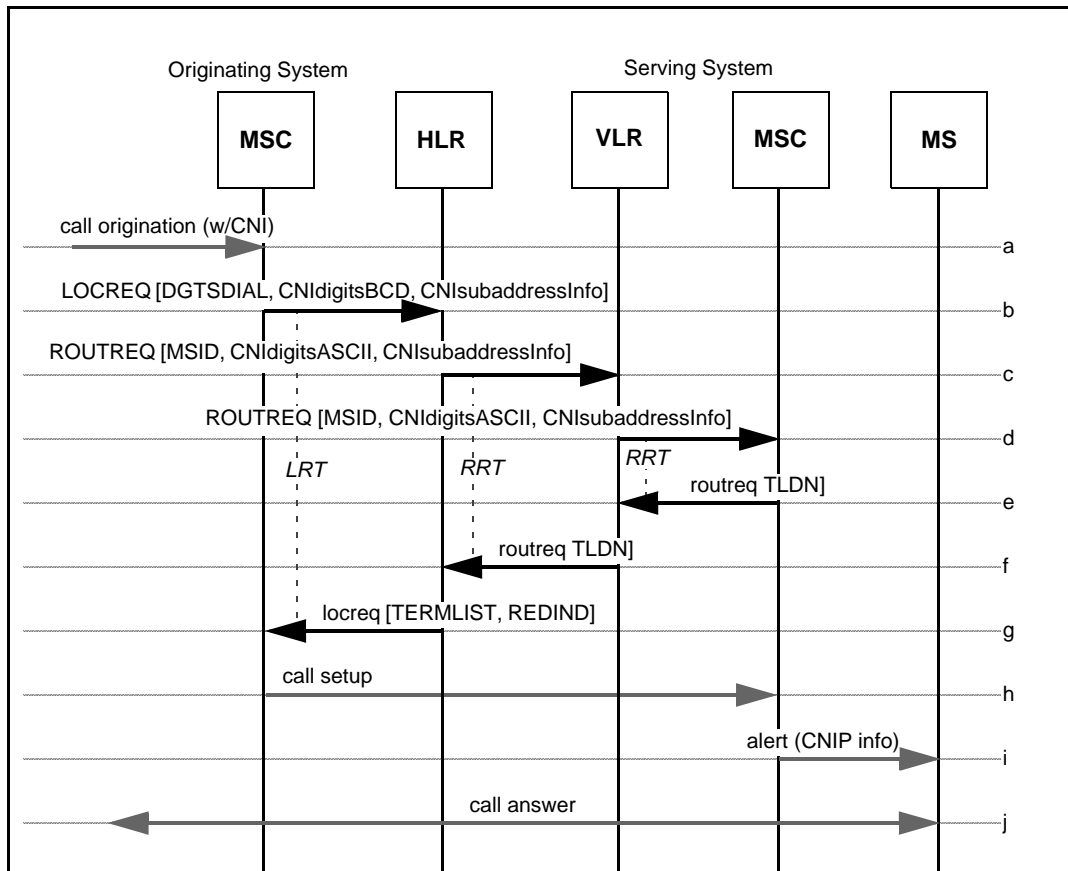

Figure 1 — CNIP Invocation to an Idle Subscriber

- a. A call origination with a dialed MS address digits (i.e., directory number) is received by the Originating MSC. Also included in the call origination is calling number identification (CNI) information, which may include: one or two calling party numbers, a calling party subaddress, a redirecting number, and a redirecting subaddress.
- b. The Originating MSC sends a `LOCREQ` to the MS's HLR, including parameters based on the CNI information received in Step a.

Additional Parameters	Usage	Type
CNIdigitsBCD:	CNI digits parameters in BCD format:	
[CallingPartyNumber-Digits1]	Calling number digits (network-provided), incl. presentation restriction information.	R
[CallingPartyNumber-Digits2]	Calling number digits (user-provided), incl. presentation restriction information.	O
[RedirectingNumber-Digits]	Redirecting number digits, incl. presentation restriction information.	O
CNIsubaddressInfo:	CNI subaddress information:	
[CallingPartySubaddress]	Calling number subaddress (user-provided).	O
[RedirectingSubaddress]	Redirecting number subaddress.	O

- c. The HLR constructs a `ROUTREQ`, including parameters based on the CNI information received in Step b, and sends it to the VLR where the MS is registered.

Additional Parameters	Usage	Type
CNIdigitsASCII:	CNI digits parameters in ASCII format:	
[CallingPartyNumber-String1]	Calling number digits (network-provided), incl. presentation restriction information.	R
[CallingPartyNumber-String2]	Calling number digits (user-provided), incl. presentation restriction information.	O
[RedirectingNumber-String]	Redirecting number digits, incl. presentation restriction information.	O
CNIsubaddressInfo:	CNI subaddress information:	
[CallingPartySubaddress]	Calling number subaddress (user-provided).	O
[RedirectingSubaddress]	Redirecting number subaddress.	O

- d. The VLR forwards the `ROUTREQ` to the current Serving MSC. Parameters are as in Step c.
- e. In reaction to the `ROUTREQ`, the Serving MSC checks its internal data structures and determines that the MS is currently idle. Therefore the Serving MSC allocates a `TLDN` and returns this information to the VLR in the `roureq`. The Serving MSC stores the received CNI information.
- f. The VLR sends the `roureq` to the HLR.
- g. When the `roureq` is received by the HLR, it returns a `locreq` to the Originating MSC. The `locreq` includes routing information in the form of the `TerminationList` parameter, along with an indication of the reason for extending the incoming call (i.e., for CD) in the `DMH_RedirectionIndicator` parameter.

- 1  
2  
3  
4  
5  
6  
7  
8  
9  
10  
11  
12  
13  
14  
15  
16  
17  
18  
19  
20  
21  
22  
23  
24  
25  
26  
27  
28  
29  
30  
31  
32  
33  
34  
35  
36  
37  
38  
39  
40  
41  
42  
43  
44  
45  
46  
47  
48  
49  
50  
51  
52  
53  
54  
55  
56  
57
- h. A voice path is then established between the Originating MSC and the Serving MSC using protocols defined by the interconnection method.<sup>1</sup>
  - i. When the inter-MSC call is received at the Serving MSC, the MS is alerted. Included in the alert is the appropriate Calling Number Identification Presentation information.
  - j. When the served MS answers, the call is established.

---

58  
59  
60

<sup>1</sup> If SS7 ISUP is used end-to-end, the IAM message can be used to deliver CNI information.

## 2.2 CNIP Interaction with CW

This scenario describes CNIP invocation to a busy, authorized MS for which CW is active.

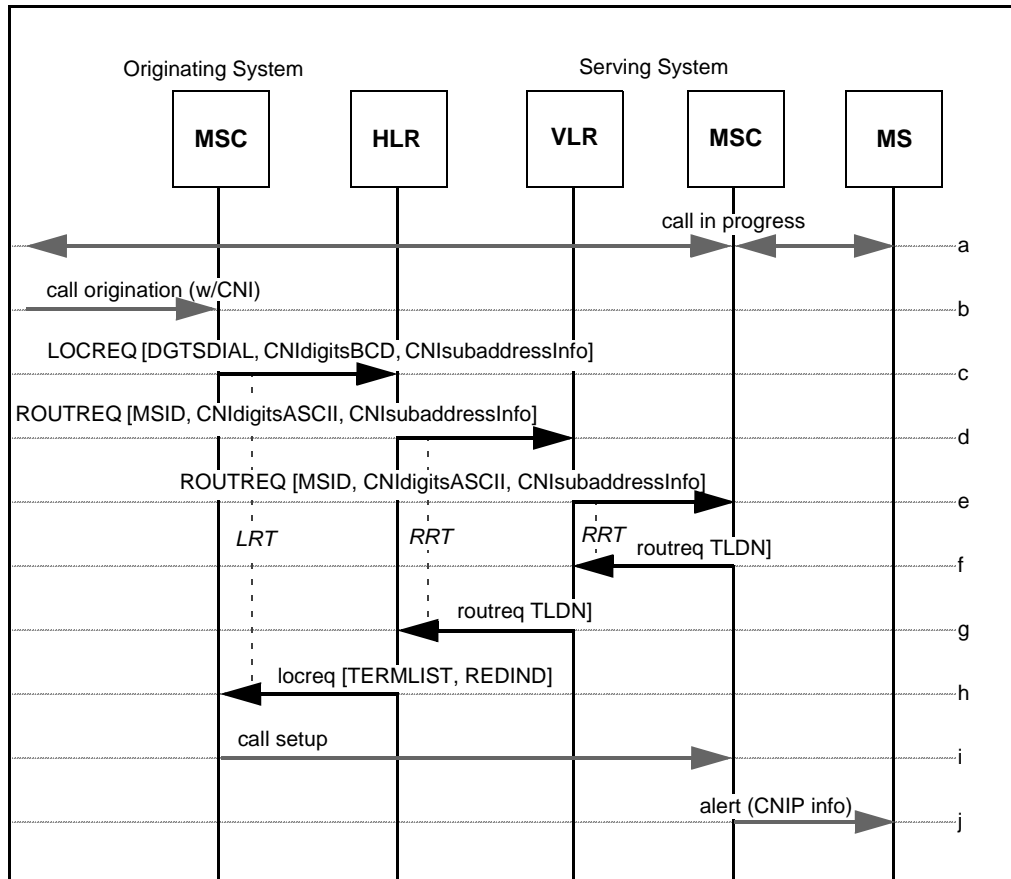

Figure 2 — CNIP Interaction with CW

- a. A call involving the served MS is in progress.
- b-e. Same as CNIP, Section 2.1, Steps a-d, respectively.
- f. In reaction to the ROUTREQ, the Serving MSC checks its internal data structures and determines that the MS is busy in another call but has CW active. Therefore, the Serving MSC allocates a TLDN (Temporary Local Directory Number) and returns this information to the VLR in the routreq. The Serving MSC stores the received CNI information.
- g-i. Same as CNIP, Section 2.1, Steps f-h, respectively.
- j. When the (second) inter-MSC call is received at the Serving MSC, the Serving MSC provides the MS with a CW notification. Included in the notification is the appropriate Calling Number Identification Presentation information.

1  
2  
3  
4  
5  
6  
7  
8  
9  
10  
11  
12  
13  
14  
15  
16  
17  
18  
19  
20  
21  
22  
23  
24  
25  
26  
27  
28  
29  
30  
31  
32  
33  
34  
35  
36  
37  
38  
39  
40  
41  
42  
43  
44  
45  
46  
47  
48  
49  
50  
51  
52  
53  
54  
55  
56  
57  
58  
59  
60

## 2.3 CNIP Interaction with CW After Handoff

This scenario describes CNIP invocation to a busy, authorized MS for which CW is active, after intersystem handoff of the MS.

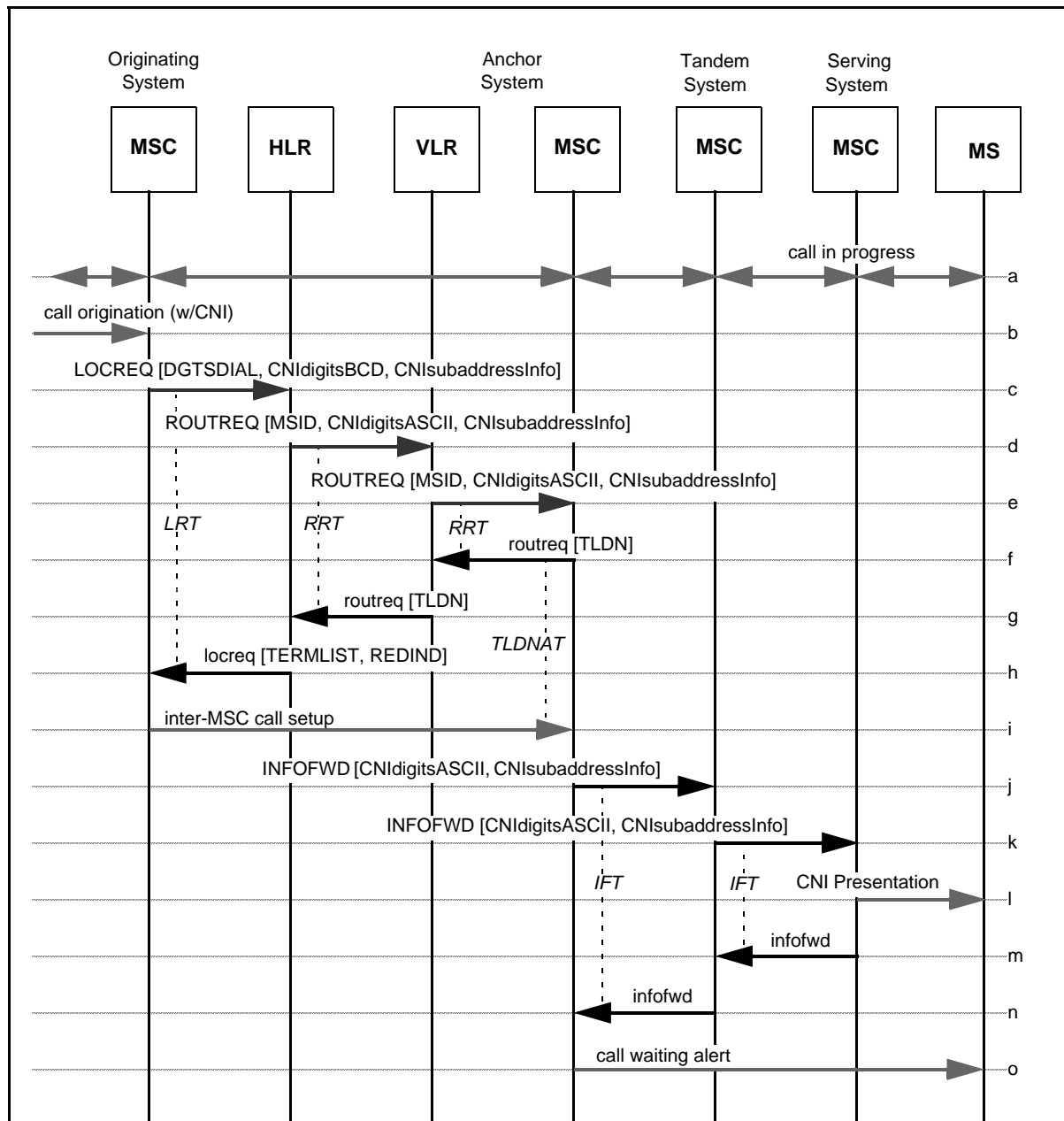

Figure 3 — CNIP Interaction with Call Waiting After Handoff

- a. A call involving the served MS is in progress.
- b-e. Same as CNIP, Section 2.1, Steps a-d, respectively.
- f. In reaction to the **ROUTREQ**, the Serving MSC checks its internal data structures and determines that the MS is busy in another call but has CW active. Therefore, the Serving MSC allocates a TLDN (Temporary Local Directory Number) and returns this information to the VLR in the **roureq**. The Serving MSC stores the received CNI information.

- g-i. Same as CNIP, Section 2.1, Steps f-h, respectively.
- j. The Anchor MSC then sends an INFOFWD to the Tandem MSC, including the CNI information.

Additional Parameters	Usage	Type
CNIdigitsASCII:	CNI digits parameters in ASCII format:	
[CallingPartyNumber-String1]	Calling number digits (network-provided), incl. presentation restriction information.	R
[CallingPartyNumber-String2]	Calling number digits (user-provided), incl. presentation restriction information.	O
[RedirectingNumber-String]	Redirecting number digits, incl. presentation restriction information.	O
CNIsubaddressInfo:	CNI subaddress information:	
[CallingPartySubaddress]	Calling number subaddress (user-provided).	O
[RedirectingSubaddress]	Redirecting number subaddress.	O

- k. The Tandem MSC adjusts the InterMSCCircuitID to identify the circuit between it and the Serving MSC, and forwards the INFOFWD to the Serving MSC.
- l. The Serving MSC presents the CNI information to the served MS in an appropriate fashion.
- m. The Serving MSC acknowledges receipt by sending an infofwd to the Tandem MSC.
- n. The Tandem MSC forwards the infofwd to the Anchor MSC.
- o. When the (second) inter-MSC call is received at the Anchor MSC, the Anchor MSC provides the MS with a Call Waiting notification.

1  
2  
3  
4  
5  
6  
7  
8  
9  
10  
11  
12  
13  
14  
15  
16  
17  
18  
19  
20  
21  
22  
23  
24  
25  
26  
27  
28  
29  
30  
31  
32  
33  
34  
35  
36  
37  
38  
39  
40  
41  
42  
43  
44  
45  
46  
47  
48  
49  
50  
51  
52  
53  
54  
55  
56  
57  
58  
59  
60

## 2.4 CNIP Interaction with CFU

This scenario describes CNIP invocation to an authorized MS for which CFU is active.

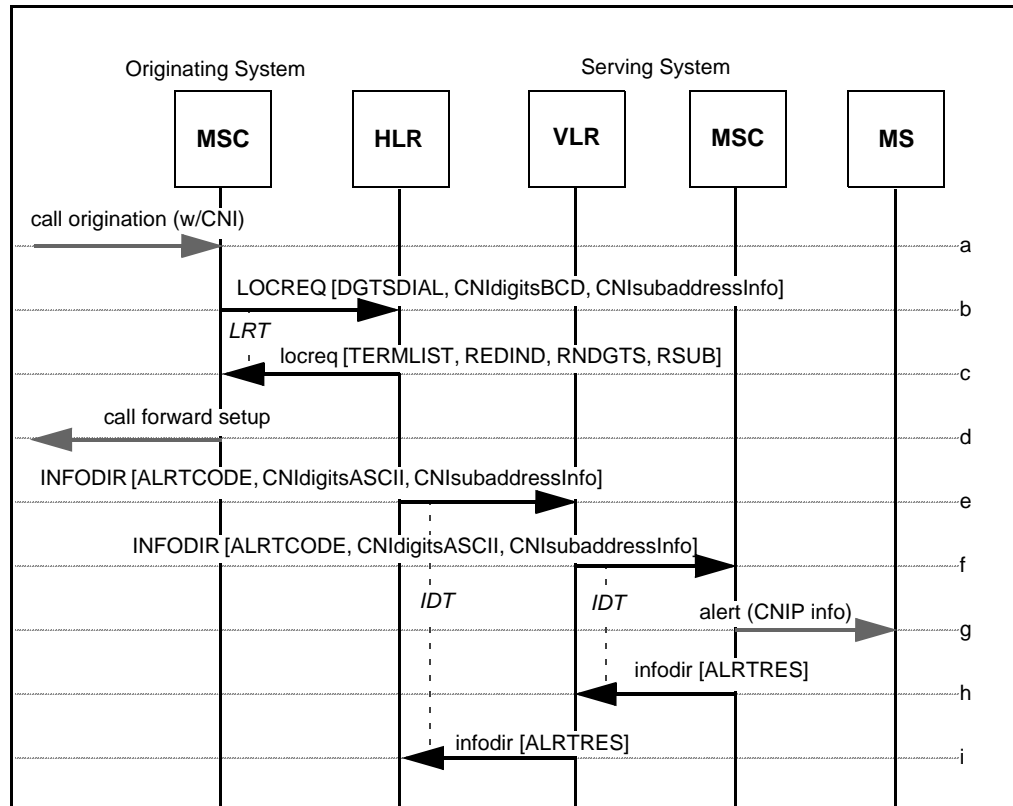

Figure 4 — CNIP Interaction with CFU

- a-b. Same as CNIP, Section 2.1, Steps a-b.
- c. The HLR determines from the MS's service profile that CFU is active. It sends a `locreq` to the Originating MSC providing the forward-to number and other routing information in the `TerminationList` parameter, along with an indication of the reason for extending the incoming call (i.e., for CFU) in the `DMH_RedirectionIndicator` parameter. It includes the MS's directory number in the `RedirectingNumberDigits` parameter. It may also include the MS's subaddress information in the `RedirectingSubaddress` parameter.

Additional Parameters	Usage	Type
RNDGTS	Redirecting number digits, set to MS's directory number.	R
RSUB	Redirecting subaddress. Include if available.	O

- d. The Originating MSC then forwards the call to the specified forward-to number, including the redirecting number information.

- e. If the HLR determines that the MS should be informed that a call has been forwarded unconditionally, it sends an INFODIR to the VLR where the MS is registered, including the CNI information.

Additional Parameters	Usage	Type
CNIdigitsASCII:	CNI digits parameters in ASCII format:	
[CallingPartyNumber-String1]	Calling number digits (network-provided), incl. presentation restriction information.	R
[CallingPartyNumber-String2]	Calling number digits (user-provided), incl. presentation restriction information.	O
[RedirectingNumber-String]	Redirecting number digits, incl. presentation restriction information.	O
CNIsubaddressInfo:	CNI subaddress information:	
[CallingPartySubaddress]	Calling number subaddress (user-provided).	O
[RedirectingSubaddress]	Redirecting number subaddress.	O

- f. The VLR directs the Serving MSC to alert the served MS by sending a INFODIR to the Serving MSC. Parameters are as in Step-e.
- g. The Serving MSC alerts the MS, if idle, via the alerting method specified AlertCode parameter in the received INFODIR; in this case, the MSC applies a single, abbreviated alert signal to the MS and waits to report paging success or failure. Included in the alert is the appropriate Calling Number Identification Presentation information.
- h. The Serving MSC sends an infodir to the VLR, including the result of the alerting action (*e.g., success, not attempted due to MS busy condition*).
- i. The VLR forwards the infodir to the HLR.

## 2.5 CNIP Interaction with CFU after Handoff

This scenario describes CNIP invocation to an authorized MS for which CFU is active, after intersystem handoff of the MS.

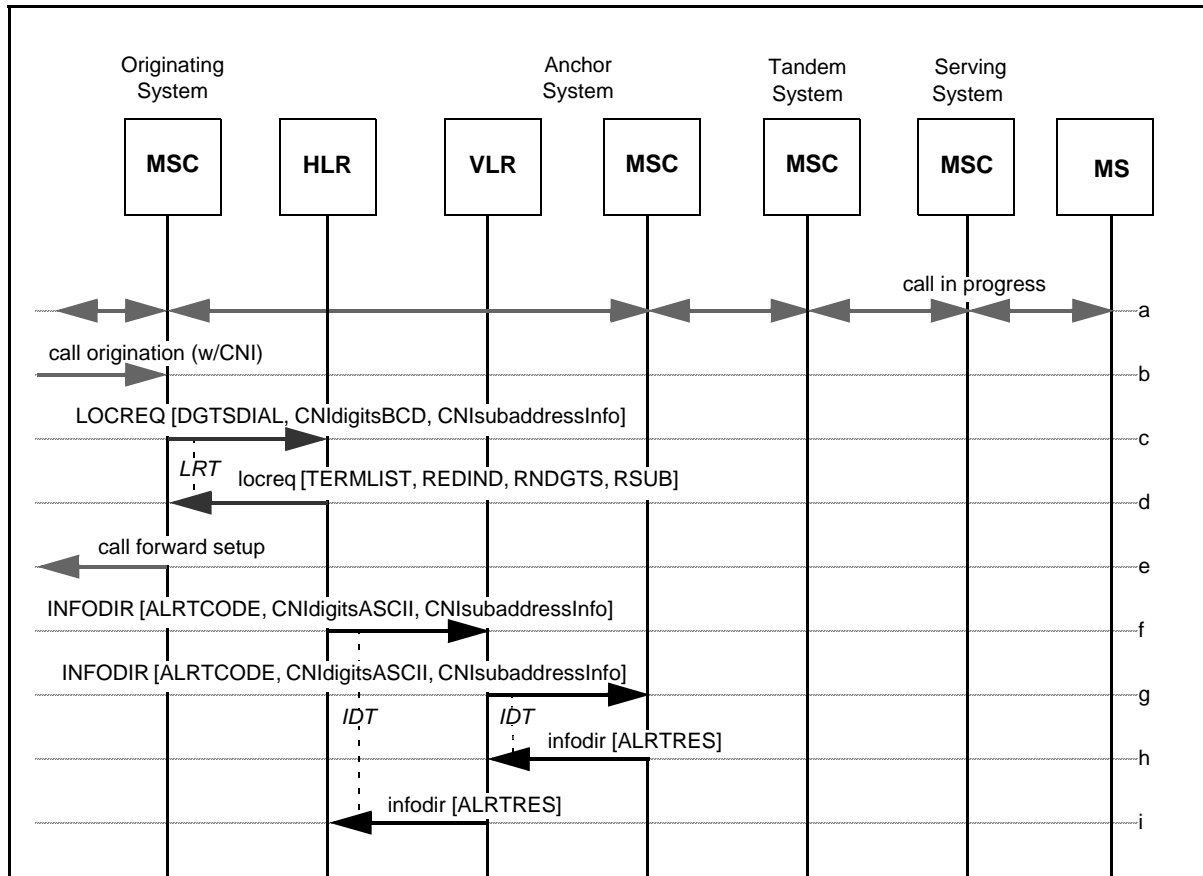

Figure 5 — CNIP Interaction with CFU After Handoff

- a. A call involving the served MS is in progress.
- b-c. Same as CNIP, Section 2.1, Steps a-b, respectively.
- d-g. Same as CNIP, Section 2.4, Steps c-f, respectively.
- h. Since the MS is busy the Anchor MSC reports a paging failure; it sends an *infodir* to the VLR, including the result of the alerting action (*i.e.*, *not attempted due to MS busy condition*).
- i. The VLR forwards the *infodir* to the HLR.

## 2.6 CNIP Invocation to a Forwarded-To Subscriber

This scenario describes CNIP invocation to a idle, authorized MS that is the forwarded-to party of a call redirection.

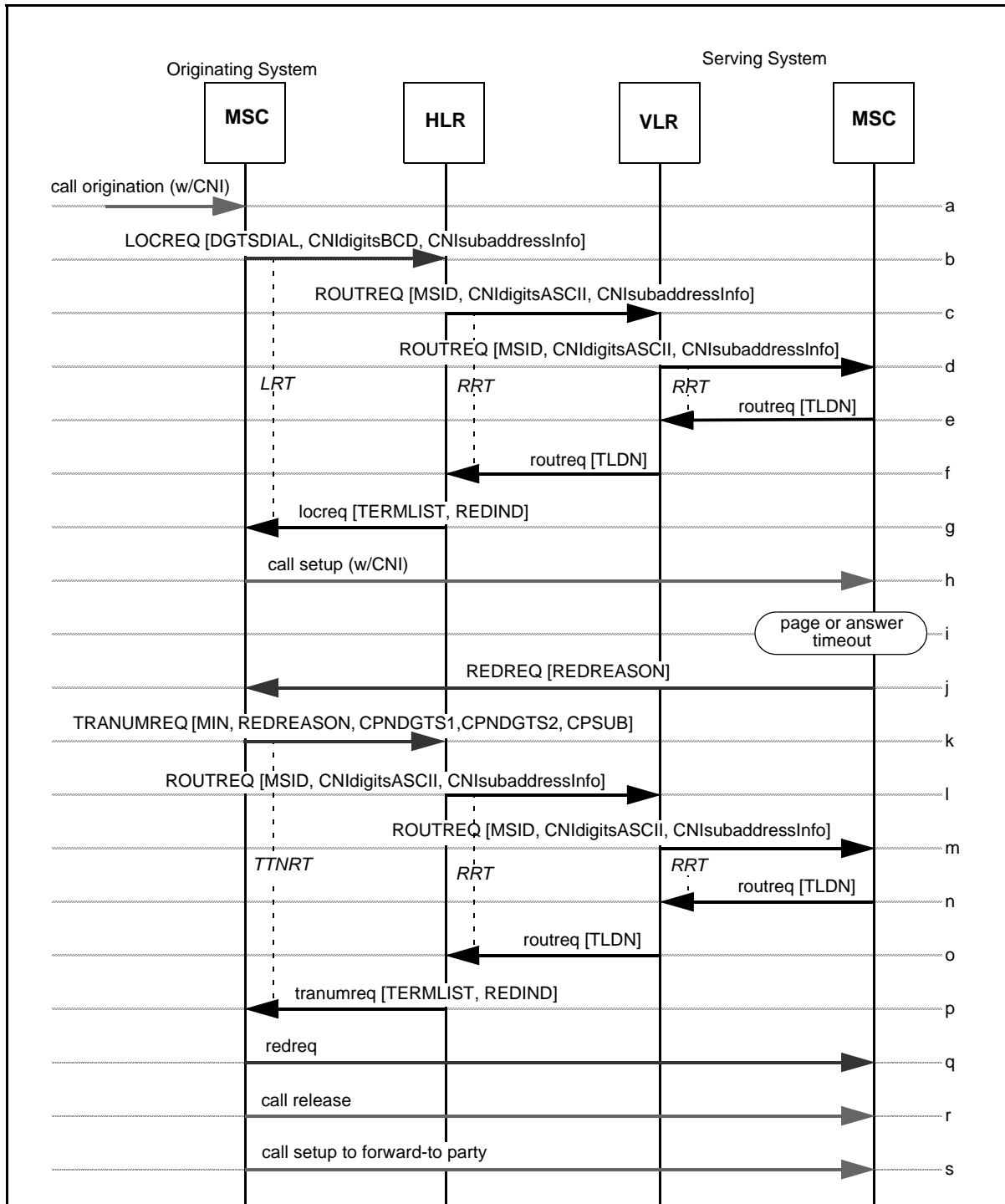

Figure 6 — CNIP Invocation to a Forwarded-To Subscriber

a-h. Same as CNIP, Section 2.1, Steps a-h, respectively.

1  
2  
3  
4  
5  
6  
7  
8  
9  
10  
11  
12  
13  
14  
15  
16  
17  
18  
19  
20  
21  
22  
23  
24  
25  
26  
27  
28  
29  
30  
31  
32  
33  
34  
35  
36  
37  
38  
39  
40  
41  
42  
43  
44  
45  
46  
47  
48  
49  
50  
51  
52  
53  
54  
55  
56  
57  
58  
59  
60

- 1 i. When the inter-MSC call is received at the Serving MSC, the MS is paged and, if a  
2 page response is received, subsequently alerted. If the MS fails to respond to the page  
3 or does not answer after alerting, the Serving MSC determines from the service profile  
4 that the MS has call forwarding active on no answer or no response to page conditions.
- 5 j. The Serving MSC sends a REDREQ to the Originating MSC, indicating that the call is  
6 being redirected due to a *no answer* or *no page response* condition.
- 7 k. The Originating MSC is able to redirect the call, therefore, it sends a TRANUMREQ to  
8 the HLR requesting the forward-to number appropriate for this condition from the  
9 MS's service profile. The Originating MSC includes in the TRANUMREQ the calling  
10 party number-related parameters that were received with the call origination at Step-a.
- 11 l. The HLR determines that the forward-to number associated with the called MS  
12 corresponds to a mobile subscriber. (The forwarded-to MS is active within the same  
13 serving VLR and MSC as the original called MS). The HLR sends a ROUTREQ to the  
14 current Serving VLR of the forwarded-to MS and includes parameters based on the  
15 CNI information received in the TRANUMREQ.
- 16 m. The VLR forwards the ROUTREQ to the current Serving MSC. Parameters are as in  
17 Step-l.
- 18 n. In reaction to the ROUTREQ, the Serving MSC checks its internal data structures and  
19 determines that the MS is currently idle. Therefore, the Serving MSC allocates a  
20 TLDN and returns this information to the VLR in the routreq. The Serving MSC  
21 stores the received CNI information.
- 22 o. The VLR sends the routreq to the HLR.
- 23 p. When the routreq is received by the HLR, it returns a tranumreq to the  
24 Originating MSC. The tranumreq includes routing information in the form of the  
25 TerminationList parameter, along with an indication of the reason for extending the  
26 incoming call (i.e., for CFD) in the DMH\_RedirectionIndicator parameter.
- 27 q. When the tranumreq is received from the HLR, the Originating MSC sends a  
28 redreq to the Serving MSC.
- 29 r. The Originating MSC releases the inter-MSC call leg.
- 30 s. The Originating MSC initiates call forwarding using the specified number. When the  
31 inter-MSC call is received at the Serving MSC, the forwarded-to MS is alerted.  
32 Included in the alert is the appropriate Calling Number Identification Presentation  
33 information.
- 34
- 35
- 36
- 37
- 38
- 39
- 40
- 41
- 42
- 43
- 44
- 45
- 46
- 47
- 48
- 49
- 50
- 51
- 52
- 53
- 54
- 55
- 56
- 57
- 58
- 59
- 60

### 3 Calling Number Identification Restriction

This section depicts the interactions between network entities in various situations related to automatic roaming and Calling Number Identification Restriction (CNIR). These scenarios are for illustrative purposes only.

#### 3.1 CNIR Temporary Activation or De-Activation with Call

This scenario describes the temporary mode activation or de-activation of CNIR by an authorized MS. The activation or de-activation occurs coincident with a call request.

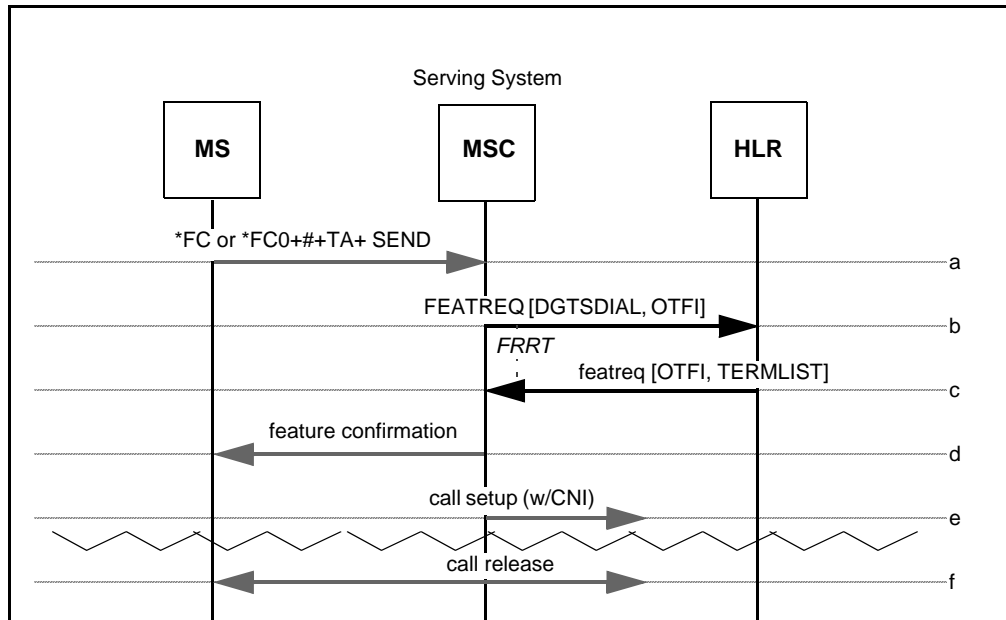

Figure 7 — CNIR Temporary Activation or De-Activation with Call

- a. A call origination and dialed digits are received by the Serving MSC. During analysis of the dialed digits, the Serving MSC detects a feature code string.
- b. The dialed digits are included in a FEATREQ and sent from the Serving MSC to the HLR associated with the MS. The Serving MSC also includes the OneTimeFeatureIndicator parameter if any of its status bits are set (i.e., if any special feature processing is active for the call).

Additional Parameters	Usage	Type
OTFI (Current Call)	Indicates special feature processing active for duration of call in progress.	O

- c. The HLR detects the authorized CNIR request and sends a featreq to the Serving MSC. The featreq includes call routing information in the TerminationList parameter. It also includes the OneTimeFeatureIndicator parameter, with an indication that CNIR is either activated or de-activated for the call.

Additional Parameters	Usage	Type
OTFI (Current Call)	Modify feature processing for duration of call in progress.	R

1  
2  
3  
4  
5  
6  
7  
8  
9  
10  
11  
12  
13  
14  
15  
16  
17  
18  
19  
20  
21  
22  
23  
24  
25  
26  
27  
28  
29  
30  
31  
32  
33  
34  
35  
36  
37  
38  
39  
40  
41  
42  
43  
44  
45  
46  
47  
48  
49  
50  
51  
52  
53  
54  
55  
56  
57  
58  
59  
60

1  
2  
3  
4  
5  
6  
7  
8  
9  
10  
11  
12  
13  
14  
15  
16  
17  
18  
19  
20  
21  
22  
23  
24  
25  
26  
27  
28  
29  
30  
31  
32  
33  
34  
35  
36  
37  
38  
39  
40  
41  
42  
43  
44  
45  
46  
47  
48  
49  
50  
51  
52  
53  
54  
55  
56  
57  
58  
59  
60

- d. The Serving MSC stores the CNIR OneTimeFeatureIndicator, activates or de-activates CNIR, and provides treatment to the served MS as indicated in the `featreq`. In this case, the treatment is to apply feature confirmation.
- e. The Serving MSC extends the call using the call routing information in the TerminationList parameter.
- f. The CNIR OneTimeFeatureIndicator remains active until the end of the call, at which time it is discarded by the Serving MSC. The presentation restriction status then returns to its pre-call condition.

### 3.2 CNIR Interaction with CFU

This scenario describes CNIR invocation for an authorized MS for which CFU is active.

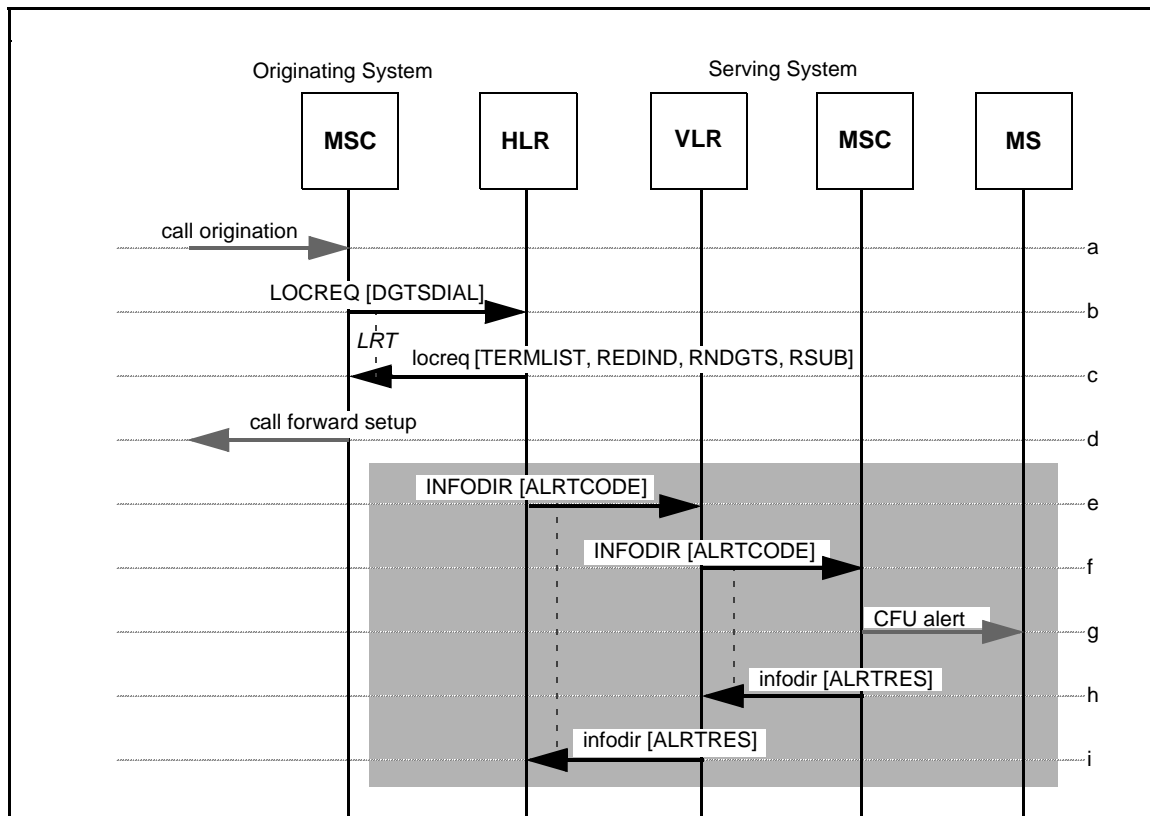

Figure 8 — CNIR Interaction with CFU

- a. A call origination and the dialed MS address digits (i.e., directory number) are received by the Originating MSC.
- b. The Originating MSC sends a LOCREQ to the MS’s HLR.
- c. The HLR determines from the MS’s service profile that CFU and CNIR are active. The HLR sends a locreq to the Originating MSC providing the forward-to number and other routing information in the TerminationList parameter, along with an indication of the reason for extending the incoming call (i.e., for CFU) in the DMH\_RedirectionIndicator parameter. It includes the MS’s directory number in the RedirectingNumberDigits parameter, with an indication that presentation is restricted. It may also include the MS’s subaddress information in the RedirectingSubaddress parameter.

Additional Parameters	Usage	Type
RNDGTS	Redirecting number digits, incl. presentation restriction information. Set to MS’s directory number.	R
RSUB	Redirecting subaddress. Include if available.	O

- d. The Originating MSC then forwards the call to the specified forward-to number, including the redirecting number information with presentation restriction indication.

1  
2  
3  
4  
5  
6  
7  
8  
9  
10  
11  
12  
13  
14  
15  
16  
17  
18  
19  
20  
21  
22  
23  
24  
25  
26  
27  
28  
29  
30  
31  
32  
33  
34  
35  
36  
37  
38  
39  
40  
41  
42  
43  
44  
45  
46  
47  
48  
49  
50  
51  
52  
53  
54  
55  
56  
57  
58  
59  
60

1  
2  
3  
4  
5  
6  
7  
8  
9  
10  
11  
12  
13  
14  
15  
16  
17  
18  
19  
20  
21  
22  
23  
24  
25  
26  
27  
28  
29  
30  
31  
32  
33  
34  
35  
36  
37  
38  
39  
40  
41  
42  
43  
44  
45  
46  
47  
48  
49  
50  
51  
52  
53  
54  
55  
56  
57  
58  
59  
60

- e. If the HLR determines that the MS should be informed that a call has been forwarded unconditionally, it sends an `INFODIR` to the VLR where the MS is registered.
- f. The VLR directs the Serving MSC to alert the MS by sending an `INFODIR` to the Serving MSC.
- g. The Serving MSC alerts the MS, if idle, via the alerting method specified `AlertCode` parameter in the received `INFODIR`; in this case, the MSC applies a single, abbreviated alert signal to the MS and waits to report paging success or failure.
- h. The Serving MSC sends an `infodir` to the VLR, including the result of the alerting action (*e.g., success, not attempted due to MS busy condition*).
- i. The VLR forwards the `infodir` to the HLR.

### 3.3 CNIR Interaction with CFNA or CFD on MS No Answer

This scenario describes CNIR invocation for an authorized MS when a no answer or no response to page condition is encountered. In addition to CNIR, the MS has CFNA or CFD (or both) active.

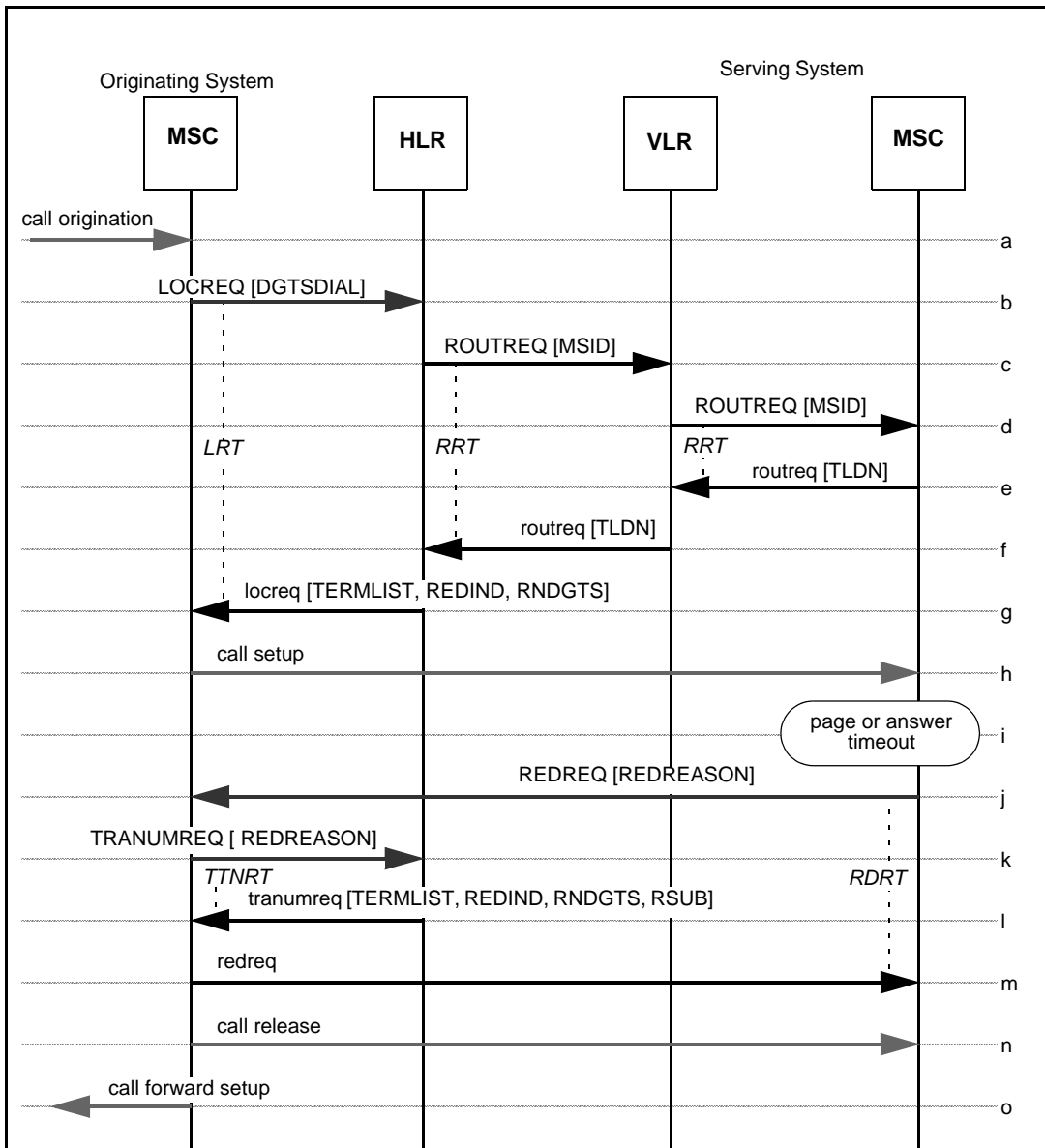

Figure 9 — CNIR Interaction with CFNA or CFD on MS No Answer

- a. A call origination and the dialed MS address digits (i.e., directory number) are received by the Originating MSC.
- b. The Originating MSC sends a LOCREQ to the HLR associated with the MS; this association is made through the dialed MS address digits (which may not be the MIN).
- c. If the dialed MS address digits are assigned to a legitimate subscriber, the HLR sends a ROUTREQ to the VLR where the MS is registered.
- d. The VLR then forwards the ROUTREQ to the current Serving MSC.

1  
2  
3  
4  
5  
6  
7  
8  
9  
10  
11  
12  
13  
14  
15  
16  
17  
18  
19  
20  
21  
22  
23  
24  
25  
26  
27  
28  
29  
30  
31  
32  
33  
34  
35  
36  
37  
38  
39  
40  
41  
42  
43  
44  
45  
46  
47  
48  
49  
50  
51  
52  
53  
54  
55  
56  
57  
58  
59  
60

- 1  
2  
3  
4  
5  
6  
7  
8  
9  
10  
11  
12  
13  
14  
15  
16  
17  
18  
19  
20  
21  
22  
23  
24  
25  
26  
27  
28  
29  
30
- e. The Serving MSC allocates a TLDN (Temporary Local Directory Number) and returns this information to the VLR in the `routreq`.
  - f. The VLR sends the `routreq` to the HLR.
  - g. When the `routreq` is received by the HLR, it returns a `locreq` to the Originating MSC. The `locreq` includes routing information in the form of the TerminationList parameter, along with Redirecting Digits and an indication of the reason for extending the incoming call (i.e., for CD) in the DMH\_RedirectionIndicator parameter.
  - h. Upon receiving the `locreq`, the Originating MSC sets up a voice path to the Serving MSC using the protocols defined by the interconnection method.
  - i. When the inter-MS-C call is received at the Serving MSC, the MS is paged and, if a page response is received, subsequently alerted. If the MS fails to respond to the page or does not answer after alerting, the Serving MSC determines from the service profile that the MS has call forwarding active on no answer or no response to page conditions.
  - j. The Serving MSC sends a REDREQ to the Originating MSC, indicating that the call is being redirected due to a *no answer* or *no page response* condition.
  - k. The Originating MSC sends a TRANUMREQ to the HLR requesting the forward-to number appropriate for the *no answer* or *no page response* condition from the MS's service profile.
  - l. The HLR sends the `tranumreq` to the Originating MSC, including the appropriate forward-to number in the TerminationList parameter, along with an indication of the reason for extending the incoming call (e.g., for CFNA) in the DMH\_RedirectionIndicator parameter. It includes the MS's directory number in the RedirectingNumberDigits parameter, with an indication that presentation is restricted. It may also include the MS's subaddress information in the RedirectingSubaddress parameter.

Additional Parameters	Usage	Type
RNDGTS	Redirecting number digits, incl. presentation restriction information. Set to MS's directory number.	R
RSUB	Redirecting subaddress. Include if available.	O

- 31  
32  
33  
34  
35  
36  
37  
38  
39  
40  
41  
42  
43  
44  
45  
46  
47  
48  
49  
50  
51  
52  
53  
54  
55  
56  
57  
58  
59  
60
- m. When the `tranumreq` is received from the HLR, the Originating MSC sends a `redreq` to the Serving MSC.
  - n. The Originating MSC releases the inter-MS-C call.
  - o. The Originating MSC initiates call forwarding to the specified forward-to number, including the redirecting number information with presentation restriction indication.

### 3.4 CNIR Interaction with CFB or CFD on MS Busy

This scenario describes CNIR invocation for an authorized MS when an MS busy condition is encountered. In addition to CNIR, the MS has CFB or CFD (or both) active.

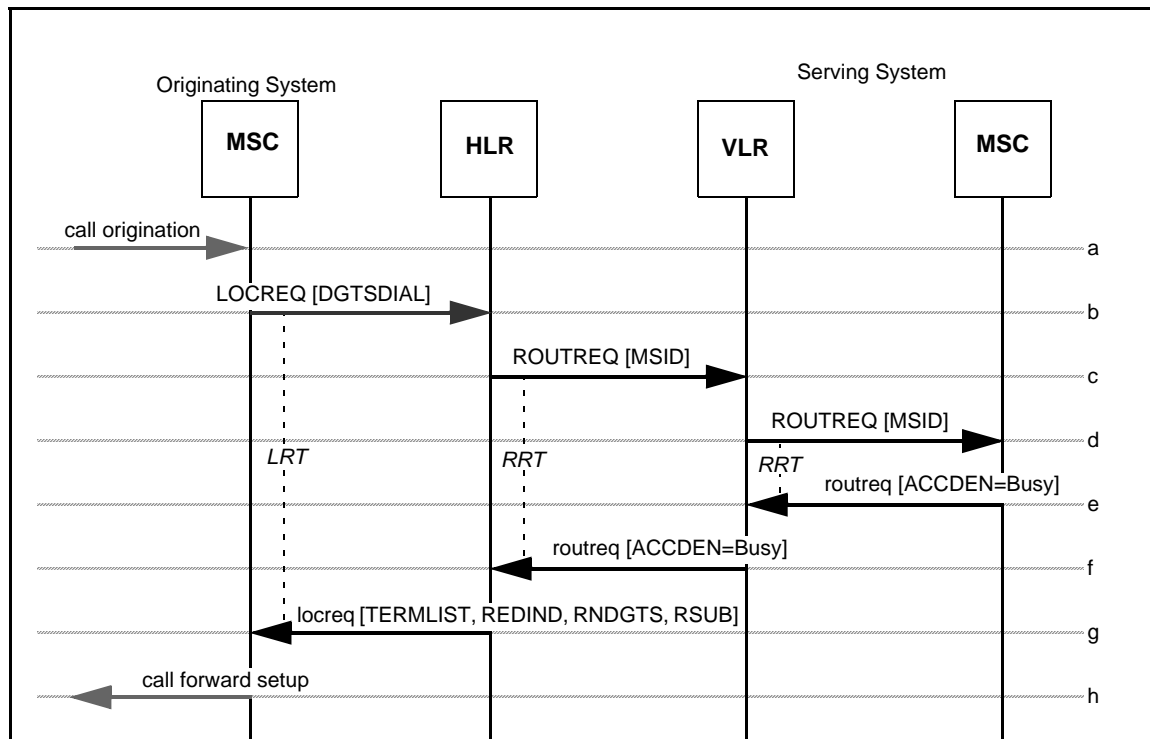

**Figure 10 — CNIR Interaction with CFB or CFD on MS Busy**

- a. A call origination and the dialed MS address digits (i.e., directory number) are received by the Originating MSC.
- b. The Originating MSC sends a LOCREQ to the HLR associated with the MS; this association is made through the dialed MS address digits (which may not be the MIN).
- c. If the dialed MS address digits are assigned to a legitimate subscriber, the HLR sends a ROUTREQ to the VLR where the MS is registered.
- d. The VLR then forwards the ROUTREQ to the current Serving MSC.
- e. In reaction to the ROUTREQ, the Serving MSC checks its internal data structures and determines that the MS is busy in another call. The status of the MS is returned to the VLR by the Serving MSC in the routreq.
- f. The VLR sends the routreq to the HLR.
- g. The HLR determines from the service profile that CFB or CFD (or both) is active. It sends a locreq to the Originating MSC providing the forward-to number and other routing information in the TerminationList parameter, along with an indication of the reason for extending the incoming call (e.g., for CFB) in the DMH\_RedirectionIndicator parameter. It includes the MS's directory number in the RedirectingNumberDigits parameter, with an indication that presentation is restricted. It may also include the MS's subaddress information in the RedirectingSubaddress parameter.

Additional Parameters	Usage	Type
RNDGTS	Redirecting number digits, incl. presentation restriction information. Set to MS's directory number.	R
RSUB	Redirecting subaddress. Include if available.	O

- 1  
2  
3  
4  
5  
6  
7  
8  
9  
10  
11  
12  
13  
14  
15  
16  
17  
18  
19  
20  
21  
22  
23  
24  
25  
26  
27  
28  
29  
30  
31  
32  
33  
34  
35  
36  
37  
38  
39  
40  
41  
42  
43  
44  
45  
46  
47  
48  
49  
50  
51  
52  
53  
54  
55  
56  
57  
58  
59  
60
- h. The Originating MSC then forwards the call to the specified forward-to number, including the redirecting number information with presentation restriction indication.

### 3.5 CNIR Interaction with CFB or CFD on Call Collision

This scenario describes CNIR invocation for an authorized MS when an MS busy condition is encountered; i.e., the MS becomes engaged in a call at the same time that the Originating MSC is delivering a call to the Serving MSC. In addition to CNIR, the MS has CFB or CFD (or both) active.

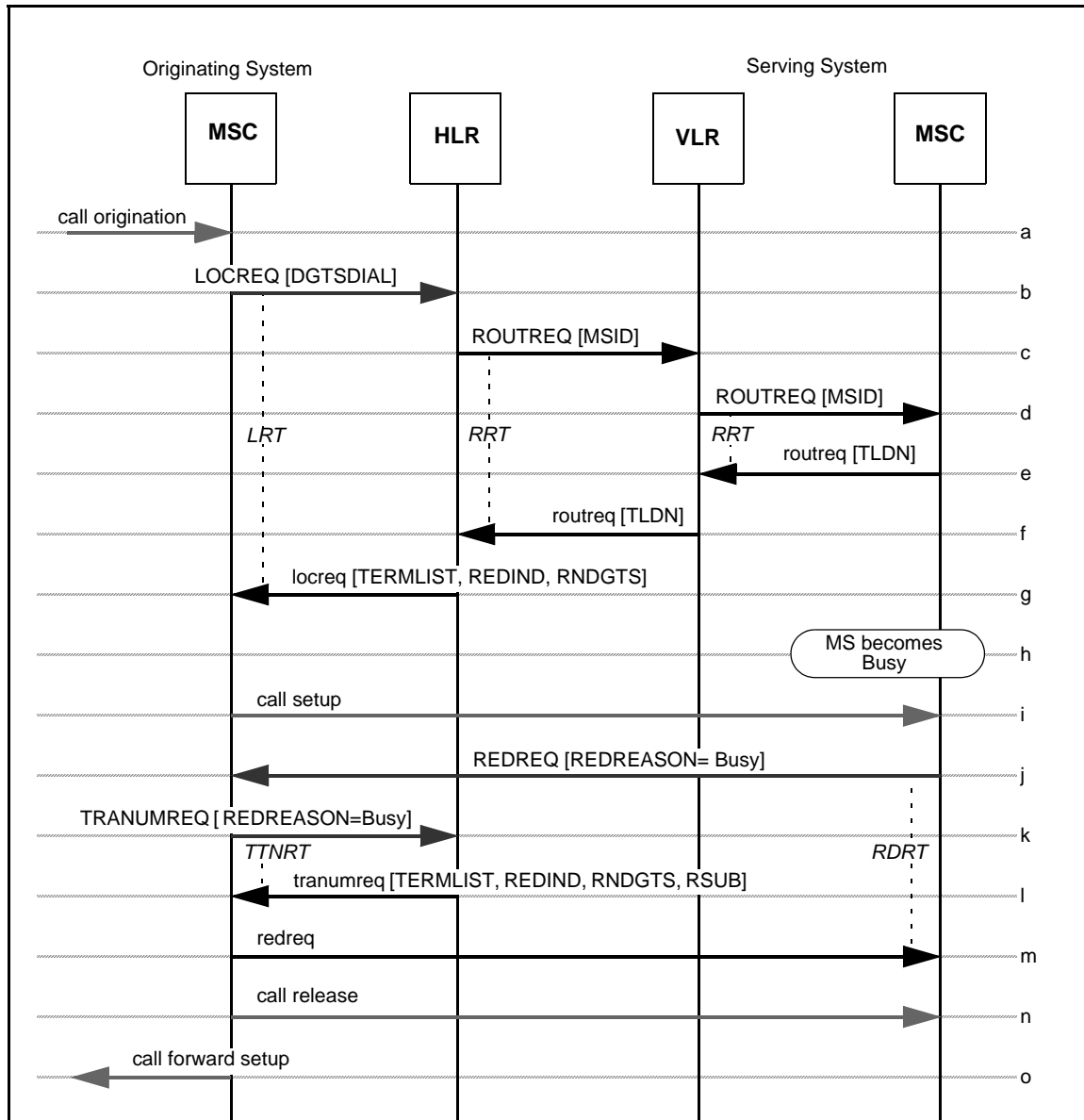

Figure 11 — CNIR Interaction with CFB or CFD on Call Collision

- a-g. Same as CNIR, Section 3.2, Steps a-g.
- h. Sometime after the Serving MSC sends the *routreq* back to the HLR, the MS becomes engaged in another call. This may be the result of an MS origination, a call through the local roamer port or the arrival of an inter-MSC call from a previous ROUTREQ.
- i. Upon receiving the *locreq*, the Originating MSC sets up a voice path to the Serving MSC using the protocols defined by the interconnection method.

1  
2  
3  
4  
5  
6  
7  
8  
9  
10  
11  
12  
13  
14  
15  
16  
17  
18  
19  
20  
21  
22  
23  
24  
25  
26  
27  
28  
29  
30  
31  
32  
33  
34  
35  
36  
37  
38  
39  
40  
41  
42  
43  
44  
45  
46  
47  
48  
49  
50  
51  
52  
53  
54  
55  
56  
57  
58  
59  
60

When the inter-MSC call is received, the Serving MSC checks its internal data structures and determines that the MS is busy in another call. The Serving MSC determines from the service profile that the MS has call forwarding on busy active.

- j. The Serving MSC then sends a REDREQ to the Originating MSC, indicating that the call is being redirected due to a *busy* condition.
- k. The Originating MSC sends a TRANUMREQ to the HLR requesting the forward-to number appropriate for the *busy* condition from the MS's service profile.
- l. The HLR sends the tranumreq to the Originating MSC, including the appropriate forward-to number in the TerminationList parameter, along with an indication of the reason for extending the incoming call (e.g., for CFB) in the DMH\_RedirectionIndicator parameter. It includes the MS's directory number in the RedirectingNumberDigits parameter, with an indication that presentation is restricted. It may also include the MS's subaddress information in the RedirectingSubaddress parameter.

Additional Parameters	Usage	Type
RNDGTS	Redirecting number digits, incl. presentation restriction information. Set to MS's directory number.	R
RSUB	Redirecting subaddress. Include if available.	O

- m. When the tranumreq is received from the HLR, the Originating MSC sends a redreq to the Serving MSC.
- n. The Originating MSC releases the inter-MSC call, and ...
- o. The Originating MSC initiates call forwarding to the specified forward-to number, including the redirecting number information with presentation restriction indication.