



---

# **Green Revised Energy Efficient Network (GREEN)**

---

---

## ***Technology Initiatives Study for cdma2000 Wireless Networks***

---

© 2011 3GPP2

*3GPP2 and its Organizational Partners claim copyright in this document and individual Organizational Partners may copyright and issue documents or standards publications in individual Organizational Partner's name based on this document. Requests for reproduction of this document should be directed to the 3GPP2 Secretariat at [secretariat@3gpp2.org](mailto:secretariat@3gpp2.org). Requests to reproduce individual Organizational Partner's documents should be directed to that Organizational Partner. See [www.3gpp2.org](http://www.3gpp2.org) for more information.*

Editor

Alex Gogic, QUALCOMM, [agogic@qualcomm.com](mailto:agogic@qualcomm.com)

## Revision History

---

| <b>Version</b> | <b>Description</b>                           | <b>Date</b>   |
|----------------|--|---------------|
| v1.0           | Initial publication                          | December 2010 |
| v2.0           | Version update to address TIA legal comments | December 2011 |

1  
2  
3  
4  
5  
6  
7  
8  
9  
10  
11  
12  
13  
14  
15  
16  
17  
18  
19  
20  
21  
22  
23  
24  
25  
26  
27  
28

## Contents

---

|   |    |
|---|----|
| List of Figures .....   | iv |
| List of Tables .....  | v  |
| Foreword.....   | 6  |
| 1 Introduction.....   | 1  |
| 1.1 Overview.....   | 1  |
| 1.2 Scope.....  | 1  |
| 1.3 Document Conventions.....   | 1  |
| 1.4 References.....   | 2  |
| 2 Acronyms, Abbreviations, and Terminology.....                       | 3  |
| 3 Target Scenarios for GREEN Study .....                              | 5  |
| 3.1 Supply of Power from Diverse Sources.....                         | 5  |
| 3.2 Controlling Femtocells and Other Household Objects .....          | 7  |
| 4 Interface Enhancements to Support GREEN.....                        | 8  |
| 4.1 Access Network Enhancements .....                                 | 8  |
| 4.1.1 RF Carrier Control as Function of Demand.....                   | 8  |
| 4.2 Radio Enhancements.....   | 17 |
| 4.3 Packet Data Network Enhancements .....                            | 17 |
| 4.4 OAM&P Enhancements.....   | 18 |
| 4.5 System Enhancements .....   | 18 |
| 4.5.1 Controlling Femtocells.....                                     | 18 |
| 4.5.2 Basic Concept .....   | 18 |
| 4.5.3 PUZL Trigger.....   | 19 |
| 4.5.4 User Zone Registration (Control Plane Signaling) Approach ..... | 20 |
| 4.5.5 Application Signaling Approach.....                             | 21 |
| 4.5.6 System Architecture Considerations.....                         | 21 |

# 1 List of Figures

---

|   |   |    |
|---|---|----|
| 2 | Figure 3.1-1: Power Supply Arrangement.....                             | 5  |
| 3 | Figure 3.1-2: Illustrative Example of Power Supply and Consumption..... | 6  |
| 4 | Figure 4.1-1: Selective RF Carrier Control in a Group of Cells.....     | 13 |
| 5 | Figure 4.5-3: Control Plane Based Architecture .....                    | 22 |
| 6 | Figure 4.5-4: Application Layer Based Architecture .....                | 24 |
| 7 | Figure 4.5-5: Hybrid Architecture.....                                  | 26 |

8

9

1 **List of Tables**

---

2 Table 4.5-1: Registration Message..... 20

3 Table 4.5-2: User Zone Registration Causes..... 21

4

5

1

## 2 Foreword

---

3 This foreword is not part of this document.

4 This 3GPP2 Study for Green Revised Energy Efficient Network (GREEN)  
5 references material initially presented in the following publication:

- 6 • SC.R5003-0 v1.0: “3GPP2 Vision for 2009 and Beyond”

7

# 1 INTRODUCTION

## 1.1 Overview

Complexity and energy sensitivities are a concern in growth and established markets alike. This GREEN Study focuses on recent improvements in energy efficiencies to the design, delivery and deployment of services and equipment in mobile networks. Specifically, enhancements to equipment power-cycles and power delivery are addressed (e.g., sleep and slumber modes for BTSs during off-peak periods of low-usage).

Energy sources will continue to shift to periodic-cycle sources such as solar energy or off-peak electrical grid for temporary storage in batteries for use during peak time slots when electricity demand rises and delivery is not as reliable.

## 1.2 Scope

This GREEN Study investigates protocol enhancements which can potentially reduce power consumption, extend battery life, and better match the available power in both network and terminal equipment. The subject of this work is a Technical Report (TR) regarding energy efficient technology solutions affecting cdma2000<sup>®1</sup> wireless telecommunication systems. Several specific items to be elaborated in this study are included in 3GPP2 Vision document. The work is not to be limited to those items alone.

## 1.3 Document Conventions

“Shall” and “shall not” identify requirements to be followed strictly to conform to this document and from which no deviation is permitted. “Should” and “should not” indicate that one of several possibilities is recommended as particularly suitable, without mentioning or excluding others, that a certain course of action is preferred but not necessarily required, or that (in the negative form) a certain possibility or course of action is discouraged but not prohibited. “May” and “need not” indicate a course of action permissible within the limits of the document. “Can” and “cannot” are used for statements of possibility and capability, whether material, physical or causal.

---

<sup>1</sup> cdma2000<sup>®</sup> is the trademark for the technical nomenclature for certain specifications and standards of the Organizational Partners (OPs) of 3GPP2. Geographically (and as of the date of publication), cdma2000<sup>®</sup> is a registered trademark of the Telecommunications Industry Association (TIA-USA) in the United States.

1 **1.4 References**

2 All references are informative.

3 [1] 3GPP2 C.S0016-D Over-the-Air Service Provisioning of Mobile  
4 Stations in Spread Spectrum Standards

5 [2] 3GPP2 C.S0005 Upper Layer (Layer 3) Signaling Standard for  
6 cdma2000 Spread Spectrum Systems

7 [3] 3GPP2 C.S0024 cdma2000 High Rate Packet Data Air Interface  
8 Specification

9

10

## 2 ACRONYMS, ABBREVIATIONS, AND TERMINOLOGY

| TERMINOLOGY                        | ACRONYM & ABBREVIATION | DEFINITION  |
|------------------------------------|------------------------|---|
| Access Terminal                    | AT                     | Device (e.g., a wireless-enabled hand-held computer) at the mobile end of HRPD wireless telecommunication link.   |
| Code Division Multiple Access      | CDMA                   | Telecommunication technology in which channel separation is accomplished by means of modulation using pseudo-random sequences (codes).  |
| Base Station                       | BS                     | Wireless network element with the primary function to link a mobile station to a wireless network.  |
| Base Transceiver Station           | BTS                    | See Base Station  |
| Blocking Rate                      | BR                     | Percentage of call attempts being blocked (unable to be served due to unavailability of resources) within a given period of time, usually an hour (e.g., Busy Hour Blocking Rate is the rate of blocking in the busiest hour of the day). |
| CDMA Channel List Message          | CCLM                   | A message broadcast by CDMA BS listing all CDMA channels available in this BS.  |
| Extended CDMA Channel List Message | ECLM                   | A version of CCLM with additional contents.   |
| Erlang                             | E                      | Unit of measure of circuit-switched traffic volume in telecommunication systems, corresponding to one voice or other circuit being occupied for one hour.   |
| Femtocell Access Point             | FAP                    | A very small BS, also known as "femtocell", designed to be installed in a home or a small office.   |
| Femtocell Convergence Server       | FCS                    | A server implementing switching and signaling function for femtocells, and an interface to the macrocellular system.  |
| Femtocell Management Server        | FMS                    | A server implementing OAM&P function for femtocells.  |
| Green Energy Efficient Network     | GREEN                  | A set of study topics related to potential standardization aimed at making cdma2000 system more energy efficient.   |
| High Rate Packet Data              | HRPD                   | Version of cdma2000 wireless standards designed to be used for packet-switched communication at high rates of transmission.   |
| Home Location Register             | HLR                    | Database for information related to cellular subscribers.   |

| TERMINOLOGY               | ACRONYM & ABBREVIATION | DEFINITION   |
|---------------------------|------------------------|--|
| Mobile Station            | MS                     | Device (e.g., a handset) at the mobile end of a wireless telecommunication link.   |
| Mobile Switching Center   | MSC                    | A functional entity implementing switching and signaling function for macrocellular system.  |
| Network Identity          | NID                    | Standardized identification given to a wireless network compliant with ANS-41 networking protocol.   |
| Power Amplifier           | PA                     | RF signal amplifier in a BS or MS  |
| Preferred User Zone List  | PUZL                   | A customized database in MS containing information related to location of and access to a set of femtocells.   |
| Quick Paging Channel      | QPC                    | CDMA forward link channel associated with Paging Channel, designed to allow reduction of MS power consumption in idle mode by further reducing on-time in slotted mode operation, to a fraction of paging slot duration.   |
| Radio Frequency           | RF                     | Frequency band used for communication between MS and BS  |
| System Identity           | SID                    | Standardized identification given to a set of wireless networks, each which is designated with a NID.  |
| TR                        |                        | Technical Report   |
| User Zone                 | UZ                     | An area in which geographical grouping of services is defined for a Mobile Station (e.g., CDMA Tiered Service defined in C.S0016-D [1]). Per C.S0016, User Zone is described by geospatial information which may be used by a Mobile Station to determine where to scan for an Access Point. |
|                           | UZRM                   | User Zone Registration Message   |
| Visitor Location Register | VLR                    | A dynamic database of MSs currently registered on an associated MSC (often VLR is implemented as part of an MSC)   |

1

2

### 3 TARGET SCENARIOS FOR GREEN STUDY

#### 3.1 Supply of Power from Diverse Sources

Interest in energy efficient solutions is growing in the mobile communications field. Techniques and technologies that contribute to reducing power consumption of network equipment can be pursued, based on the assumption that various sources of power (e.g., solar energy, battery storage, and commercial electric power) can be used to power base station and other equipment.

Figure 3.1-1 illustrates how multiple (hybrid) sources of power can be used to supply base station or other network equipment with power. In the arrangement shown, three sources of power are used: solar energy generator, commercial power grid, and battery.

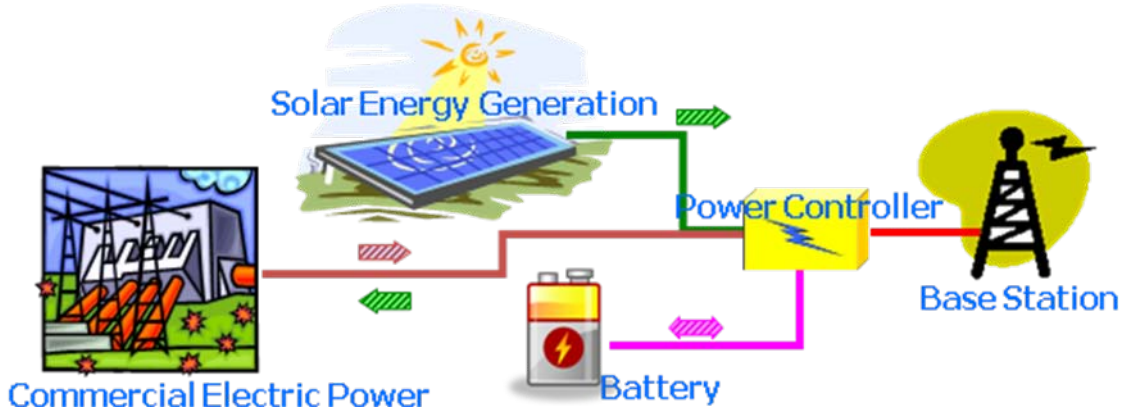
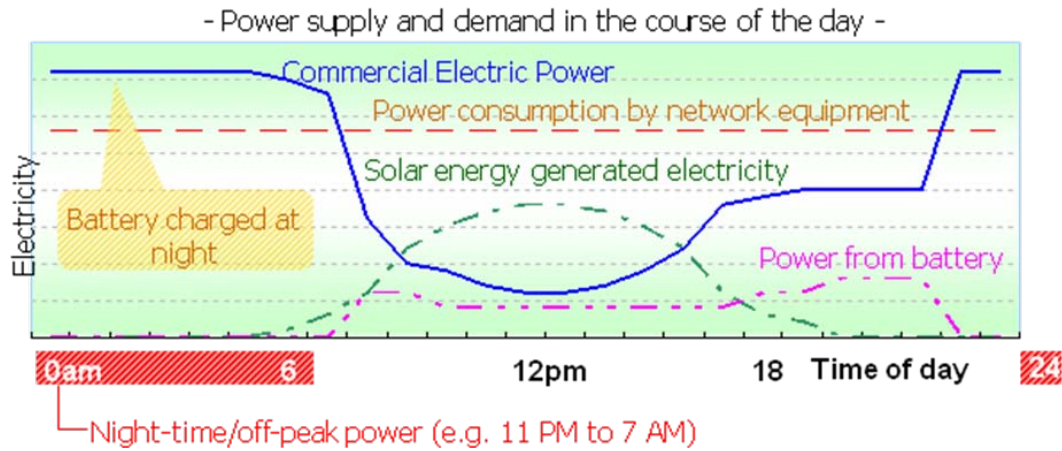

**Figure 3.1-1: Power Supply Arrangement**

The flow of power between three sources is managed by a Power Controller. During a sunny day solar panels generate much power, which can be used to directly supply the base station, with any supplemental power taken from the commercial electric grid. This reduces the power demand on the electric grid, which is at its premium during daylight hours. At night, commercial power demand is low, and can be used not only to supply the base station, but also to charge the battery. At power demand extremes in the power grid, battery can reduce reliance on the external power, and be used as a source of energy to power the base station for a short period of peak demand.

In principle, it is feasible that the commercial power grid can be fed by the excess power generated by solar panels in some situations (if solar panel power generation capacity exceeds the power consumption by the base station equipment).

1 Figure 3.1-2 is an illustrative example of variation of power use from  
 2 the three sources of power during the course of the day, as well as  
 3 power consumption by the network equipment.



4  
 5 **Figure 3.1-2: Illustrative Example of Power Supply and Consumption**

6 Solar panel generated electricity is shown in green dotted line, showing  
 7 no power generated at night, and amount of power rising during  
 8 daylight hours reaching a peak at noon, then dropping back in the  
 9 afternoon hours until it goes down to zero again at night.

10 Power from battery is shown in violet dotted line. In the example,  
 11 battery is recharged at night; hence the power from this source is  
 12 shown as zero at that time. When system demand on the commercial  
 13 electric grid starts going up in the morning, some of the charged power  
 14 from the battery is used to lessen the demand on the electric grid from  
 15 the network equipment. As solar power is entered into the equation,  
 16 the demand on the battery power peaks in the late afternoon and  
 17 evening hours, when solar source of power diminishes.

18 Commercial electric power demand curve in this example scenario is  
 19 shown in solid blue line, and it is roughly an inverse of the solar power,  
 20 with the exception that this power source is largely used for recharging  
 21 the battery. As such, the battery and solar power are used to augment  
 22 and mitigate the use of commercial electric power when it's least  
 23 available.

24 Power demand of the network equipment is shown as dashed red line,  
 25 and it is almost constant over the course of the day. Per energy  
 26 conservation theorem, the sum of the curves from the three sources of  
 27 power shown equals the power demand by the network equipment.  
 28 Figure 3.1-2 graphically illustrates that relationship.

1 Battery can be viewed as energy-neutral, since it is merely a means of  
2 time-shifting the power consumed from other sources. Solar is the  
3 energy efficient source of power, since it does not involve carbon  
4 emissions to the atmosphere. Hence, the commercial electric grid  
5 source of power remains the target for reducing carbon emissions, if we  
6 assume that at least some of the power generated in the grid is caused  
7 by carbon fuels. Hence, one can think of the area under the solid blue  
8 line in the figure as the opportunity to reduce carbon emissions.

9 In conclusion, since the peak demand for communication traffic in the  
10 example illustrated in Figure 3.1-2 is during the time between early  
11 morning hours (e.g., 6 AM) until late evening hours (e.g., 11 PM), the  
12 target of GREEN study is to look for opportunities to lower power  
13 demand in the base station in the remainder of the daily cycle (e.g., 11  
14 PM to 6 AM in the example illustrated in Figure 3.1-2). Note that the  
15 specific usage pattern illustrated in Figure 3.1-2 is only an example for  
16 a given market, and it may look differently elsewhere.

## 17 **3.2 Controlling Femtocells and Other Household Objects**

18 During a large part of the day, a home installed femtocell may idle if no  
19 one is at home. Conversely, during off-business hours, a femtocell  
20 installed at a small business premise may also idle. This idling  
21 operation results in both needless power consumption and creation of  
22 interference to the macro system, particularly if pilot beacon design is  
23 used.

24 As the adoption rate of femtocells increases, femtocell density may  
25 become as high as Wi-Fi density, or higher. The added power  
26 consumption of an idling femtocell may not significantly change the  
27 energy bill for an individual home or business. However, the  
28 cumulative effect of the power of many idle femtocells can be sizable.  
29 Environmental laws require ever increasing efficiency from appliances  
30 and other types devices (e.g., battery chargers for cell phones, laptops,  
31 or MP3 players), including automatic shutdown when idling.

32 In this GREEN target scenario, the goal is to automatically turn off  
33 power to the Femtocell Access Point or FAP (at the very minimum, the  
34 RF circuitry) when femtocell service access is not required. As an  
35 extension, the methodology can enable similar power control of certain  
36 household appliances and environmental controls (e.g., heat, air  
37 conditioning).

## **4 INTERFACE ENHANCEMENTS TO SUPPORT GREEN**

### **4.1 Access Network Enhancements**

#### **4.1.1 RF Carrier Control as Function of Demand**

##### **4.1.1.1 BS Power Consumption Considerations**

In addition to battery life considerations for user terminals, requirements for power consumption by infrastructure functional elements can also be addressed. This is in consideration of the current worldwide drive toward more efficient products and technologies. For example, the following requirement can be considered:

- Wireless traffic volumes vary with time of the day (e.g., traffic may go down at night when users are less active). Base stations supporting multiple carrier frequencies could potentially handle the lower traffic with fewer carriers by moving users to a reduced set of carriers and temporarily turning off transmission of unused ones, or the network may choose to turn off certain base stations to reduce energy consumption with the neighboring base stations if this can be accomplished with no loss of coverage.

In this example, when cellular traffic demand falls, some resources in the base station can be turned off or put on stand-by. As elaborated below, some redistribution of traffic may be necessary. The overall intended result is reduced power consumption by BS equipment.

Depending on base station design, baseband channels can typically be used in combination with any RF carrier. In principle, an unused baseband channel or channel group may be put in stand-by mode with the result that power consumed by baseband processing equipment can be reduced. However, since a physical element typically has multi-channel capability, use of a single channel or all channels in that element results in the need to power up the entire element. In this case, the power consumption does not vary significantly regardless of how many channels are in use within the element.

Baseband processing circuits account for a much lower portion of the total BS power when compared with RF equipment. In particular, a Power Amplifier (PA) is an element with significant power consumption. An RF carrier can use a distinct PA, or a PA may serve multiple RF carriers in a given sector. Either way, if an entire PA or a portion of the carriers served by a PA can be turned off, the power savings can be considerable.

#### 1 **4.1.1.2 Control Procedure Outline for cdma2000 1x**

2 The primary objective is to use existing standards-based capabilities to  
3 automatically control RF carriers as a function of demand. This is illustrated  
4 in the section below.

5 The following terminology is used:

6 N Total number of cdma2000-1x RF carriers deployed ( $N > 1$  in this  
7 discussion)

8 R Number of cdma2000-1x RF carriers being turned off when  
9 demand falls ( $R = 1$  to  $N-1$ ).

10 Note that turning off carriers may be conducted in multiple steps of  
11 varying R.

12 The system monitors network load in each BS and computes running average  
13 of load (Erlangs) and blocking rate (BR). The system also projects the BR when  
14 R carriers are turned off (i.e.,  $N-R$  carriers operating). If the projected BR is  
15 below an operator specified target level, the system initiates a traffic  
16 redistribution sequence and turns off the unneeded RF carriers.

17 The traffic redistribution sequence (i.e., the redistribution of traffic based on a  
18 reduction of number of active carriers) may consist of the following steps:

19 Step 1: Reconfigure CDMA Channel List Message to exclude R carriers  
20 targeted to be turned off; Simultaneously, increment MSG\_SEQ (see  
21 details below) parameter in that message.

22 This is intended to signal to idle mobiles to begin re-hashing on a  
23 reduced set of  $N-R$  RF carriers (see step 3 below). Note that the choice of  
24 which RF carrier(s) to turn off can be based on considerations to reduce  
25 adjacent channel interference (i.e., the remaining  $N-R$  carriers need not  
26 necessarily be adjacent to each other).

27 Step 2: Reconfigure the Neighbor Lists of neighboring cells, if required.

28 Step 3: Start assigning new traffic to a reduced set of  $N-R$  carriers.

29 Note that the MS checks the CDMA Channel list message prior to  
30 entering access state, either as response to a page or to send call  
31 origination message. Therefore, if a MS had not yet re-hashed to one of  
32  $N-R$  RF carriers, it will do so as part of the procedure to enter the access  
33 state. This will minimize the possibility of channel assignment on a  
34 different RF carrier, and therefore maintain maximum possible call setup  
35 reliability.

36 Step 4: For the period of time T31m (600 s), page MSs on both old and new RF  
37 carriers (i.e., assuming hashing among  $N$  and  $N-R$  carriers, respectively).

38

1 T31m is a timer defining maximum time for which configuration  
2 parameters are considered valid (see [C.S0005]). Since this timer runs  
3 independently for each MS, the exact time when the mobile rehashes to  
4 the new set of RF carriers is not known. However, all mobiles will be re-  
5 hashed within the T31m time period.

6 Step 5: Upon expiration of T31m, on any of the R carriers targeted for shut-  
7 down, perform inter-frequency hard handoff of active connections to  
8 distribute among the remaining N-R carriers.

9 Typical call duration is much less than T31m (see below for a  
10 probabilistic estimate). However, there may be cases when a mobile is on  
11 a conference call that lasts a long time and therefore needs to be moved  
12 from a RF carrier targeted for shut-down.

13 Step 6: Turn off R carrier(s).

14 The associated PA can be shut down entirely if the RF carrier or all  
15 carriers served by the PA are being shut down. If a PA serves multiple  
16 carriers, not all of which are being shut down, the procedure may still  
17 result in some power consumption reduction, since pilot, synch, and  
18 paging channels for that carrier are shut down. Each operator can  
19 examine the PA power consumption specifications and decide whether or  
20 not, in their specific case, such RF carrier shutdown without PA  
21 shutdown is desirable.

22 The inverse sequence may occur when traffic demand starts to increase. The  
23 steps are briefly outlined here:

24 Step 1: Monitor Erlang load and BR running average, or a similar statistic  
25 measure.

26 Step 2: Project Erlang load and BR several minutes ahead, and if those values  
27 exceed operator specified target levels, power additional RF carrier(s) as  
28 needed. Alternatively, historical time-of-day load information can be  
29 used as a trigger.

30 Step 3: Reconfigure the Neighbor Lists of neighboring cells, if required.

31 Note: This may not be required for the case that the entire system is  
32 controlled uniformly.

33 Step 4: Reconfigure CDMA Channel List Message to include newly powered-on  
34 R carrier(s); Simultaneously increment MSG\_SEQ (see details below).

35 Step 5: For the period of T31m, page MSs on both the old and the new RF  
36 carrier (assuming hashing among N and N-R carriers, respectively).

37 Step 6: Optionally, assign new traffic to R newly turned-on carriers until load  
38 equalizes.

1 Each of the two sequences outlined above can be implemented with variants:  
 2 conducted in single or multiple steps during the daily control cycle; turning  
 3 on/off one or more RF carriers at a time.

4 To gain an insight as to how many connections may need to undergo hard  
 5 handoff before turning target RF carriers off, the following numerical examples  
 6 are provided for several different assumptions of average and standard  
 7 deviation of call holding time.

8 • With a very conservative assumption of 250 s average and 180 s  
 9 standard deviation, the percentage of traffic left on carrier(s) targeted for  
 10 shut-down after expiration of 600 s is 2.6% in average.

11 • Smaller hold times are more typical values for current user behavior.  
 12 Today in many markets, the trend is a diminishing average voice call  
 13 duration, which can be traced to an increase in the smart phone  
 14 penetration and popularity of messaging and other data communication  
 15 services. People with smart phones are busy doing other things with  
 16 their phones than talking.

17 Recent average call duration in developed markets is less than 120  
 18 seconds. With a standard deviation assumed to be 60 seconds, the  
 19 percentage of traffic remaining after 600 s reduces to 0 (an “8 sigma”  
 20 event).

21 Each operator can do the calculation on the basis of their own actual call  
 22 holding time characteristics. This need not necessarily be approximated by  
 23 Gaussian distribution, but could be actual call duration characteristics data,  
 24 as available for that operator’s network deployment.

#### 25 **4.1.1.3 Role of MSG\_SEQ Parameters**

26 In this section, the role of MSG\_SEQ parameters in executing the procedures  
 27 outlined in the previous section is considered.

28 The existing cdma2000 procedures employ a message sequence structure  
 29 which is used by the network to indicate to the mobiles if any of the network  
 30 parameters have changed. This reduces the need for the mobile station to  
 31 always read system parameters and keep them up to date, as well as the need  
 32 to synchronize precisely the transmission of control messages with mobile’s  
 33 paging cycles.

34 CONFIG\_MSG\_SEQ indicates the current message sequence number for  
 35 several control messages, including CDMA Channel List Message and its  
 36 variants (e.g., Extended CDMA Channel List Message). The MSG\_SEQ is  
 37 contained in each of these control messages and the MS stores a separate  
 38 MSG\_SEQ for each of the control messages.

1 In order to implement the redistribution of idle mobiles in the re-configurations  
 2 discussed in the previous sections, the following needs to occur at the base  
 3 station that is being re-configured:

- 4 • (Extended) CDMA Channel List Message (CCLM/ECLM) is changed to a  
 5 reduced or expanded set, as appropriate
- 6 • CONFIG\_MSG\_SEQ is incremented in CCLM/ECLM and other  
 7 configuration messages

8 The above is sufficient to effect the transitions associated with turning RF  
 9 carriers on and off. However, additional steps supported in the standard can  
 10 supplement the procedure as follows:

- 11 • BS sets the paging indicators for all mobile stations to “ON” for each QPC  
 12 (Quick Paging Channel) slot for a time interval T (in units of 1.28  
 13 seconds), such that  $T = 1.28 \text{ s} * M * 2^{\text{MAX\_SLOT\_CYCLE\_INDEX}}$ .

14 According to C.S0005 [2], M is defined as the number of slots in a  
 15 maximum paging channel cycle. M is defined as:

$$16 \quad M = 2^i \times 16 \quad \text{for } 0 \leq i \leq 7$$

17 where i is equal to MAX\_SLOT\_CYCLE\_INDEX as defined in the System  
 18 Parameter Message.

- 19 • If the BS supports configuration change indicators on the QPC, when  
 20 changing CONFIG\_MSG\_SEQ, the BS sets all configuration change  
 21 indicators to “ON” for each QPC slot for a time interval of T31m.

22 Next, the MS behavior during RF carrier up/down transition is considered.

23 CONFIG\_MSG\_SEQ is included in the General Page Message, allowing MS to  
 24 determine whether the stored configuration parameters are current without  
 25 having to wait for a system configuration message. When timer T31m expires,  
 26 the MS can quickly determine if the configuration has changed by examining  
 27 MSG\_SEQ in the General Page Message (received in its regular paging slot). If  
 28 the configuration has not changed, the MS can restart its T31m timer and  
 29 resume slotted mode operation immediately.

30 When the configuration changes during RF carrier up/down sequence, all MSs  
 31 will become aware of CONFIG\_MSG\_SEQ change within T31m. If the optional  
 32 QPC related BS processing described above is used, the MS will become aware  
 33 of the change in the next paging slot.

34 MS compares received the CONFIG\_MSG\_SEQ with the stored  
 35 CHAN\_LST\_MSG\_SEQ. Since there will be a mismatch in this case, the MS  
 36 updates the CDMA channel list upon receiving CDMA Channel List Message  
 37 and rehashes to a new RF carrier. For the case of turning off RF carriers, the  
 38 result is that idle mobiles will vacate R carriers and move to the remaining N-R  
 39 carriers.

#### 1 **4.1.1.4 Neighbor List Re-Configuration**

2 One of the fundamental questions associated with controlling RF carriers as a  
 3 function of demand is how granular spatially to implement it. In other words,  
 4 does the system make decisions to turn RF carriers OFF and ON based on  
 5 individual BS traffic load, or is that applied to a larger territory (e.g., in large  
 6 sections of a city, or city-wide).

7 For city-wide control area, the procedures are simplified, at least for the cells in  
 8 the interior of the territory being reconfigured, since neighbor configurations  
 9 remain unchanged as the control sequences are executed. In these cases,  
 10 adjustment of the neighbor list is not required.

11 When individual BSs are being controlled, or at the seam of a larger territory  
 12 being controlled, neighbor configurations are adjusted commensurate with  
 13 each control sequence. This is illustrated in Figure 4.1-1, showing a cluster of  
 14 cells 1 ~ 13, where RF carriers in a smaller cluster 1~ 3 are being turned  
 15 ON/OFF, while others retain the same RF carrier configuration.

16

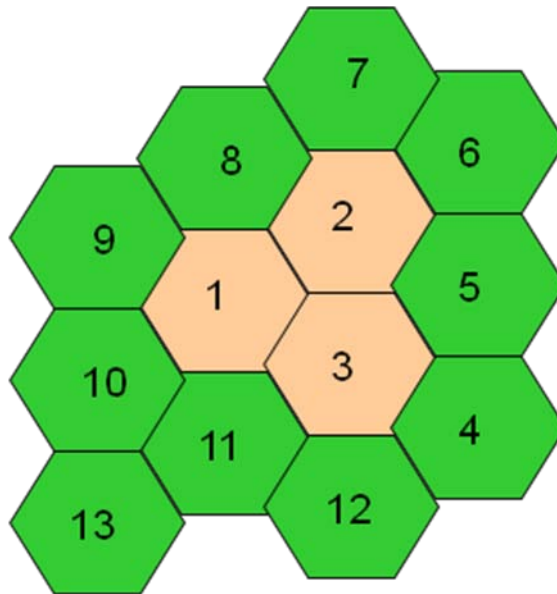

17

18 **Figure 4.1-1: Selective RF Carrier Control in a Group of Cells**

19 cdma2000 standards allow the system to convey some information to MSs  
 20 about neighbor list entries of each cell. The parameter NGHBR\_CONFIG is  
 21 associated with each entry in the neighbor list and can take one of several  
 22 values, which assist the MS in idle handoff.

- 23 • NGHBR\_CONFIG values of '000', '001' indicate that the neighbor cell is  
 24 configured:
  - 25 ○ with the same number of RF carriers containing paging channels;

- 1           ○ with the same RF carriers assignment and same number of paging
- 2           channels;
- 3           ○ with the same ordinal position in Channel List message.
- 4       • NGHBR\_CONFIG value of '010' indicates that the number of RF carriers
- 5       in the subject neighbor cell may be different.

6 In the example above, prior to turning off carriers in cells 1~3, the parameter  
7 NGHBR\_CONFIG is set to '000' or '001' – the latter indicates existence of  
8 Primary Paging Channel in the neighbor cell. At the time CCLM/ECLM is  
9 changed to reduce the number of RF carriers, the NGHBR\_CONFIG values are  
10 also changed for each neighbor from the set 4~13, and pair-wise for its  
11 corresponding neighbor from that set.

12 For example, assuming that cell 3 has neighbor cells 1, 2, 5, 4, 12, 11, and 13,  
13 then the following neighbors will undergo re-configurations:

- 14       • Neighbors 5, 4, 12, 11, and 13 in cell 3 neighbor list
- 15       • Neighbor 3 in neighbor lists of cells 5, 4, 12, 11, and 13

16 A similar analysis applies to cells 1 and 2.

#### 17 **4.1.1.5 Femtocell System Impact**

18 It can be noted that typically the distinct SID/NID pairs control the MS  
19 behavior for macro/femto mobility respectively (e.g., registration when moving  
20 between the macro and femtocell systems). These parameters remain  
21 unaffected by the changes described above in CDMA channel list and neighbor  
22 list re-configuration.

23 If pilot beacon based design is used by the femtocell system, the list of  
24 frequencies for the hopping beacon may be affected. The simple rule is, if a  
25 macro cell whose RF carriers are being turned ON/OFF is in the femtocell's  
26 neighbor list, then that femtocell's hopping beacon is affected. If there is more  
27 than one macro neighbor in a femtocell's neighbor list, the effect is applicable  
28 only if all of the macro neighbors' RF carriers are being turned ON/OFF.

29 Alternatively, an operator may choose not to control the hopping beacons (i.e.,  
30 to continue running the beacons as if no macro re-configuration took place).

31 If RF carriers targeted for turning ON and OFF are such that femtocell  
32 deployment option is transformed from macro/femto reuse to dedicated  
33 femtocell RF carrier, it is desirable that there would not be any impact on re-  
34 configuration. However, users may be impacted (e.g., femtocell coverage may  
35 perceptively change, which may be considered to be a negative impact).  
36 Therefore, the approach of effectively changing femtocell RF deployment option  
37 (co-channel to dedicated channel) is preferable to be avoided by the operator.

38 An important aspect of a successful femtocell system design is the ability of a  
39 FAP to observe the macro system at the locale where the FAP is installed (e.g.,

1 measure the receive signal strength, evaluate neighbors, etc.), if the FAP has  
 2 this capability. In this case, the FAP can properly set its own transmit power,  
 3 configure its neighbor list, etc. Since the FAP may be turned ON and OFF (e.g.,  
 4 by the owner when not in use), the FAP may be re-evaluating its surroundings  
 5 relatively frequently. Typically, the femtocell system infrastructure controls the  
 6 process of such evaluation (e.g., tells the FAP which macro frequency to  
 7 monitor for such purposes). This is a consideration when turning macro RF  
 8 carriers ON and OFF. To reduce the need for FAP re-configurations, it is  
 9 preferred that a macro RF frequency that is used for monitoring by the FAP to  
 10 not be targeted for being powered off.

11 The NGHBR\_CONFIG parameter (described in detail in section 4.1.1.4) can be  
 12 set to '010', indicating that the number of RF carriers in the subject neighbor  
 13 cell may be different. That tells the mobile that it needs to read configuration  
 14 message once it does idle hand-out. This setting of NGHBR\_CONFIG will  
 15 remain unchanged regardless of what macro RF configuration change  
 16 occurred.

#### 17 **4.1.1.6 Control Procedure Outline for HRPD RF Carrier Shutdown**

18 The primary objective is to use existing standards-based capabilities (see  
 19 C.S0024 [3]) to automatically control RF carriers as a function of demand. This  
 20 is illustrated in the section below.

21 The following terminology is used:

- 22 N Total number of HRPD RF carriers deployed (N>1 in this  
 23 discussion)
- 24 R Number of HRPD RF carriers being turned off when demand falls,  
 25 or turned on when demand increases (R= 1 to N-1).

26 Note that turning off carriers may be conducted in multiple steps of  
 27 varying R.

28 The system monitors network load in each BS and computes running average  
 29 of load in terms of the throughput on a per-BS and on a per-carrier basis for  
 30 each of the BS. The system also projects the load when R carriers are turned  
 31 off (i.e., N-R carriers operating). If the projected load is below an operator  
 32 specified target level, the system initiates a traffic redistribution sequence and  
 33 turns off the unneeded RF carriers in a base station or the selected base  
 34 stations.

35 The traffic redistribution sequence for the reduction of number of active  
 36 carriers may consist of the following steps (see C.S0024 [3] for usage of  
 37 parameters mentioned in the description):

38 Step 1: Reconfigure SectorParameters Message to exclude R carriers targeted  
 39 to be turned off; Simultaneously, update the SectorSignature (see details

1 below) parameter in SectorParameters message and in the QuickConfig  
2 message update the 'SectorSignature' field to the new value.

3 This is intended to signal to idle mobiles to begin re-hashing on a  
4 reduced set of N-R RF carriers (see step 3 below). Note that the choice of  
5 which RF carrier(s) to turn off can be based on considerations to reduce  
6 adjacent channel interference (i.e., the remaining N-R carriers need not  
7 necessarily be adjacent to each other).

8 Step 2: Reconfigure the Neighbor Lists of neighboring sectors, if required

9 Note: This may not be required for the case that the entire system is  
10 controlled uniformly.

11 Step 3: Start assigning new traffic to a reduced set of N-R carriers.

12 Note that the AT detects a change in the SectorParameters when it finds  
13 that the SectorSignature parameter in the QuickConfig is different from  
14 the SectorSignature in the last stored SectorParameters message.

15 Step 4: For the period of time  $T_{OMPQCSupervision} + T_{OMPSPSupervision}$ , page ATs on both  
16 old and new RF carriers (i.e., assuming hashing among N and N-R  
17 carriers, respectively).

18  $T_{OMPQCSupervision}$  is the time duration for which the AT waits to receive the  
19 next QuickConfig message.  $T_{OMPSPSupervision}$  is the time duration between  
20 transmissions of the SectorParameters message.

21 Step 5: On any of the R carriers targeted for shut-down, perform inter-  
22 frequency hard handoff of active connections to distribute among the  
23 remaining N-R carriers, if required.

24 Step 6: Turn off R carrier(s).

25 The associated PA can be shut down entirely if the RF carrier or all  
26 carriers served by the PA are being shut down. Each operator can  
27 examine the PA power consumption specifications and decide whether or  
28 not, in their specific case, such RF carrier shutdown without PA  
29 shutdown is desirable.

30 The inverse sequence may occur when the traffic load picks up, for example in  
31 the early morning hours when traffic demand starts to increase. The steps are  
32 briefly outlined here:

33 Step 1: Monitor the running average of the aggregate system load from the  
34 active RF carriers.

35 Step 2: Project the load several minutes ahead. If those values exceed operator  
36 specified target levels, power additional RF carrier(s) as needed.  
37 Alternatively, historical time-of-day load information can be used as a  
38 trigger.

39 Step 3: Reconfigure the Neighbor Lists of neighboring cells, if required.

1 Step 4: Reconfigure SectorParameters message to include newly powered-on R  
2 carrier(s); Simultaneously update SectorSignature.

3 Step 5: For the period of  $T_{OMPQCSupervision} + T_{OMPSPSupervision}$ , page MSs on both the  
4 old and the new RF carrier (assuming hashing among N and N-R  
5 carriers, respectively).

6 Step 6: Optionally, assign new traffic to R newly turned-on carriers until load  
7 equalizes.

8 Each of the two sequences outlined above can be implemented with variants:  
9 conducted in single or more steps in the course of times when the traffic load  
10 increases (for example, morning) or decreases (for example, evening); turning  
11 on/off one or more RF carriers at a time.

#### 12 **4.1.1.7 Control Procedure Outline for BS Shutdown**

13 The network can also make a determination that the base station can be shut  
14 down completely based on traffic load and determination that the ATs currently  
15 being served by that base station can be served by one of the neighboring base  
16 stations.

17 The detailed steps in the scenario where the redistribution of traffic as a result  
18 of completely shutting down a base station is left for any subsequent  
19 specification development, as determined in the work item driven process.

20

## 21 **4.2 Radio Enhancements**

22 Radio interfaces of cdma2000 family of standards (cdma2000 1x and HRPD)  
23 provide support for protocols conducive to energy efficiency.

24 Section 4.1 contains detailed procedures on how RF carriers can be turned off  
25 and on as traffic demand changes in the course of the day. Section 4.5.1  
26 contains procedures on how a femtocell can be turned off automatically, as  
27 authorized users leave the area, or conversely, turned on when at least one  
28 authorized user approaches the area. Similar procedures are applicable for the  
29 case of picocell deployment.

30 The procedure to control macrocell RF carriers is fully compatible with legacy  
31 terminals. The femtocell procedure is for the most part compatible with the  
32 legacy radio interface procedures, however, to enable the intended  
33 functionality, mobiles need to be provisioned and mobile resident application  
34 downloaded and activated.

35

## 36 **4.3 Packet Data Network Enhancements**

37 No specific standards impact has been identified.

1  
2  
3  
4  
5  
6  
7  
8  
9  
10  
11  
12  
13  
14  
15  
16  
17  
18  
19  
20  
21  
22  
23  
24  
25  
26  
27  
28  
29  
30  
31  
32  
33  
34  
35

## **4.4 OAM&P Enhancements**

Section 4.1 describing RF carrier controls as a function of traffic demand can be viewed as an opportunity to enhance OAM&P specifications in support of those procedures, including daily traffic fluctuation analysis, determination of specific triggers to turn an RF carrier or carriers on and off, etc. Provisioning aspects of OAM&P may be applicable to femtocell controls described in Section 4.5.1.

## **4.5 System Enhancements**

### **4.5.1 Controlling Femtocells**

As outlined in Section 3.2 the objective is to develop enhancements which would enable power of much of the femtocell circuitry to be automatically turned off and on, depending on whether or not femtocell service access is required.

This section contains recommendations for a standards-based tool set that could be used by femtocell equipment developers to develop automated power-saver operations in their products with the understanding that the overall power-saving feature design would be a proprietary implementation of that tool set.

### **4.5.2 Basic Concept**

The familiar PUZL (Preferred User Zone Location) concept (see C.S0016-D [1]) can be used to implement “proximity based control” of a femtocell as follows:

- When the MS enters the Home Zone, the femtocell is notified;
- When the MS leaves the Home Zone, the femtocell is notified;
- Based on the presence in the Home Zone of mobile stations associated with this femtocell, femtocell power may be reduced.

This can be extended from femtocell controls to controlling other objects as part of a “smart grid” concept (e.g., appliances, heat, air conditioning, lights, etc.) which can be programmed to be remotely controlled based on some rules, where mobile device proximity status is one of the rules.

In the sections below, two design options are shown, both using PUZL as trigger:

- 1       • User Zone Registration approach (a.k.a. Control Plane Signaling  
2        approach)
- 3       • Application Layer Signaling approach

4       The PUZL based trigger is applicable for cdma2000-1x operation.  
5       Although PUZL is not applicable for HRPD operation, the procedures  
6       described for the “proximity based control” equally apply for HRPD  
7       femtocells. Appropriate signaling mechanisms can be used in the  
8       HRPD operation to approximate the location of the user for triggering  
9       the “proximity based control”.

10      Though PUZL is particularly convenient, other application based trigger  
11      mechanisms can be used (e.g., a geo-fencing application running GPS)  
12      for triggering “proximity based control”.

### 13

#### 14   **4.5.3 PUZL Trigger**

15      PUZL is described in detail in C.S0016-D [1]. Briefly stated, PUZL is an  
16      individualized database stored in a mobile device which may list  
17      femtocells that this mobile device is authorized to use. The MS can  
18      generate and retain PUZL-like information as it learns locations of  
19      femtocells of interest based on its unique pattern of movement (e.g.,  
20      home, office, cafés the user frequents, user’s friends’ homes).

21      In this application of PUZL, a specifically designated PUZL entry, herein  
22      referred to as Home User Zone (HUZ) is programmed to trigger  
23      proximity indication signaling by the MS.

24      The HUZ concept can be extended to multiple PUZL entries for other  
25      locations, each of which triggers such signaling. In each case, this HUZ  
26      signaling can have a distinct meaning, and can cause a distinct  
27      network behavior or distinct action or set actions of a network-resident  
28      application.

29      Note that HUZ (or any other PUZL entry) can be as coarse as a macro  
30      cell or a group of macro cells, but could be refined in more advanced  
31      designs. C.S0016-D [1] already contains parameters that allows such  
32      refinement.

33      The basic concept of the HUZ PUZL trigger is that the MS signals to the  
34      network or to an application server indicating its entrance to or exit  
35      from the HUZ.

#### 4.5.4 User Zone Registration (Control Plane Signaling) Approach

In this approach, the PUZL trigger described in the previous section causes control plane signaling message to be generated by the MS.

General structure of cdma2000 registration message is shown in Table 4.5-1.

**Table 4.5-1: Registration Message**

|                  |      |
|------------------|------|
| REG_TYPE         | 4    |
| SLOT_CYCLE_INDEX | 3    |
| MOB_P_REV        | 8    |
| SCM              | 8    |
| MOB_TERM         | 1    |
| RETURN_CAUSE     | 4    |
| QPCH_SUPPORTED   | 0/1  |
| ENHANCED_RC      | 0/1  |
| UZID_INCL        | 0/1  |
| UZID             | 0/16 |

Message fields of interest are highlighted in yellow, specifically:

- REG\_TYPE: Registration type. The value of '0111' is User Zone Based registration type, as defined in C.S0005 [2] (See Section 2.6.5.1.10).
- RETURN\_CAUSE: Reason of the MS registration or access – this is elaborated upon in the text below.
- UZID: User Zone ID: A 16-bit field which identifies which particular user zone triggered the registration message. This is also defined in C.S0005 [2] for P\_REV 6 or higher. UZID allows more than one “designated” user zone, each of which can have its own unique application (e.g., in addition to the HUZ, which may be defined as the one controlling the femtocell power on or off).

Table 4.5-2 outlines the RETURN\_CAUSE field values in Registration Message. Values in the range '0000' to '0101' are standardized in C.S0005. Highlighted in yellow are two new proposed fields taken from a previously reserved set of values, specifically applicable to User Zone Registration:

1 **Table**

| RETURN_CAUSE | Redirect Failure Condition                          |
|--------------|---|
| 0000         | Normal Access                                       |
| 0001         | Service redirection failed - system not found       |
| 0010         | Service redirection failed - protocol mismatch      |
| 0011         | Service redirection failed - registration rejection |
| 0100         | Service redirection failed – wrong SID              |
| 0101         | Service redirection failed – wrong NID              |
| ...          | Reserved  |
| 1001         | User Zone Registration on entry                     |
| 1010         | User Zone Registration on exit                      |
| ...          | Reserved  |

- 2
- 3 • ‘1001’: User Zone Registration on entry. When the MS enters a
  - 4 User Zone, it would include this value in the RETURN\_CAUSE of
  - 5 the User Zone Registration Message (UZRM).
  - 6 • ‘1010’: User Zone Registration on exit. When the MS exits a User
  - 7 Zone, it would include this value in the RETURN\_CAUSE of the
  - 8 UZRM.

9 Newly proposed RETURN\_CAUSE values are backward compatible with  
10 older versions of C.S0005 [2].

### 11 **4.5.5 Application Signaling Approach**

12 Approach is similar, but MS uses application signaling to convey  
13 entry/exit to a designated zone. The trigger is the same as outlined in  
14 Section 4.4.1.2, using PUZL database stored in the MS. The difference  
15 here is, rather than initiating control plane signaling, the trigger causes  
16 the MS to signal zone entry/exit to an M2M server.

17 In this approach, the wireless system core network is not directly  
18 involved in processing the signaling message. Hence, applications for  
19 controlling the femtocell power on/off, as well as for any other function  
20 (e.g., controlling heat or air conditioning in the household), can be  
21 facilitated by an M2M server.

### 22 **4.5.6 System Architecture Considerations**

23 This section contains brief high level architecture considerations, which  
24 would allow the development of functionality to control femtocell (or  
25 another object) on/off based on MS proximity status.

**4.5.6.1.1 Control Plane Based Architecture Option**

This section outlines the control plane based architecture option illustrated in Figure 4.5-3.

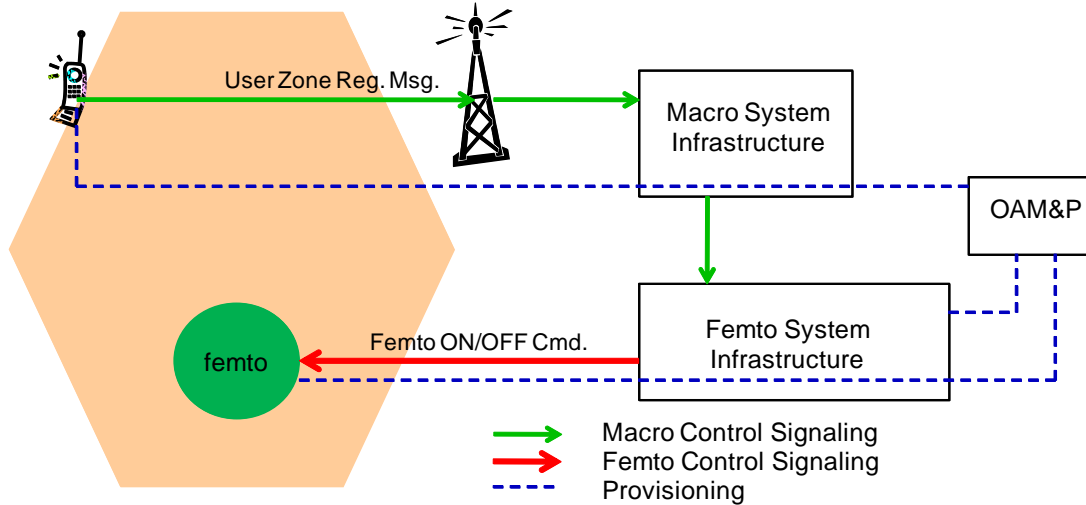

**Figure 4.5-3: Control Plane Based Architecture**

The User Zone surrounding the femtocell (illustrated as a green circle) is depicted as a hexagonal shape in beige. When the MS enters the User Zone, the control cycle begins by the PUZL trigger, causing the MS to send a UZRM (see Section 4.4.1.3) with the following parameters:

- RETURN\_CAUSE: '1001' - User Zone Registration on entry;
- UZID\_INCL: '1' - Yes;
- UZID: Identity of the PUZL entry associated with this User Zone.

The UZRM, as any other registration message, is forwarded by the Access Network to the macro system core network, containing the identity of the MS, as well as contents of the Registration Message, including the parameters listed. So far, the behavior of the macro system is unchanged relative to the existing standards, though the RETURN\_CAUSE had been previously undefined in the standards.

There are several alternative ways to realize this function. A very high level description follows, leaving it up to the standardization effort, if undertaken, to analyze options and specify the details.

Similar principles apply with HRPD network.

1 UZRM, which propagates to the macro system core network, would be  
2 forwarded to the femtocell system infrastructure, requiring new  
3 functionality subject to standardization in the macro core network, as  
4 well as the femtocell system infrastructure. This could require a new  
5 interface from HLR/VLR/MSC to FCS/FMS to be defined.

6 The femtocell system infrastructure, based on the identities of the  
7 user(s) (MS ID and UZID), and in accordance with the control logic for  
8 this GREEN application, commands the FAP to turn all its circuitry  
9 that is not essential for FAP backhaul communication off or on.

#### 10 **4.5.6.1.2 Application Layer Architecture Option**

11 This section outlines the application layer based architecture option  
12 illustrated in Figure 4.5-4.

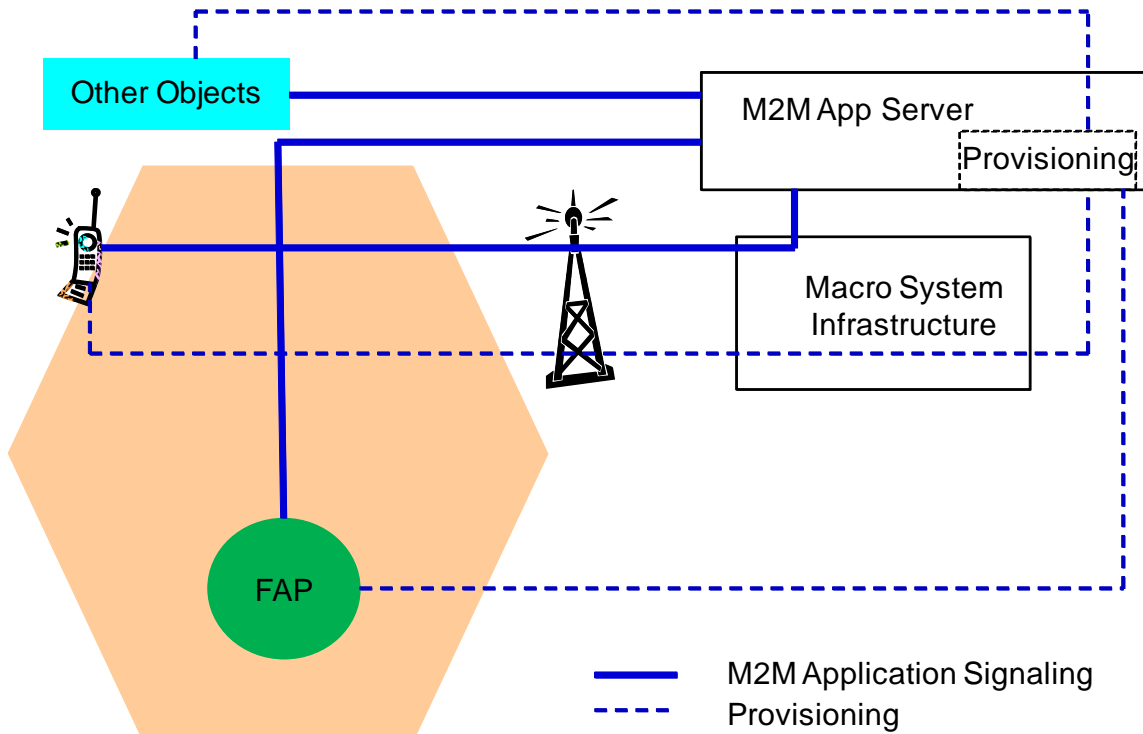

**Figure 4.5-4: Application Layer Based Architecture**

The trigger is the same as described under control plane based option in Section 4.4.1.5.1 (MS detects proximity of a femtocell can be either PUZL based, or any other out-of-band technique like GPS). For the case of PUZL, the trigger occurs when the MS enters the User Zone causing the MS to detect a PUZL match. However, instead of sending a UZRM, this initiates application layer signaling from the MS to an M2M application server. The macro system RAN and other macro infrastructure serve only to transport this signaling, and they are oblivious to its contents. The exact contents of application layer messages are left for detailed standardization, or for the application itself to define. In principle, similar information is conveyed by the MS to the M2M server, as was the case for control plane signaling option, namely:

- MS identity;
- User Zone Identity;
- Entry or exit;

1 Based on application logic, the M2M application server interacts with  
2 the FAP to control its power on/off. This can be done independently of  
3 FMS (as implied in Figure 4.5-4), or in concert with it (e.g., instead of  
4 directly controlling the FAP, the M2M application server interacts with  
5 the FMS and uses it as an intermediary. In the former case, the  
6 femtocell system infrastructure is not involved in the system  
7 implementation. CS-only devices may use SMS or USSD for signaling  
8 interactions with M2M Application Server. PS devices can use IP for  
9 message exchange. In either case, the messages would be exchanged  
10 transparently to legacy macro networks.

11 Extension of this application to other objects of control (e.g., lighting,  
12 heating, air conditioning, TV set-top boxes) is straightforward, as  
13 implied in Fig. 4.5-4. Rather than controlling the femtocell, M2M  
14 application server interacts with those other objects to retrieve status  
15 information, as well as to control them, driven by MS proximity events  
16 described.

17 For the system to work as described, some provisioning needs to take  
18 place, such as:

- 19 • The application software needs to be downloaded to the MS;
- 20 • The MS needs to be configured with the address of the M2M  
21 application server;
- 22 • The MS needs to be configured to trigger application layer signaling  
23 when it determines proximity to the femtocell by mechanisms such  
24 as PUZL, GPS etc.;

25 Provisioning of objects of control, including the FAP (unless FMS is  
26 used as intermediary), is also necessary, for example, exchange of  
27 security credentials, provisioning of M2M server address for the object  
28 to use when reporting status, etc.

29 Provisioning can be implemented by the M2M server or it can be  
30 implemented independently (e.g., implemented by facilities offered by  
31 the wireless network operator's OAM&P system).

#### 32 **4.5.6.1.3 Hybrid Architecture Option**

33 Hybrid architecture is also feasible, where control plane signaling is  
34 used as the initial trigger conveyed to the femtocell system  
35 infrastructure, but the application logic is "outsourced" to an M2M  
36 server. This is illustrated in Fig 4.5-5.

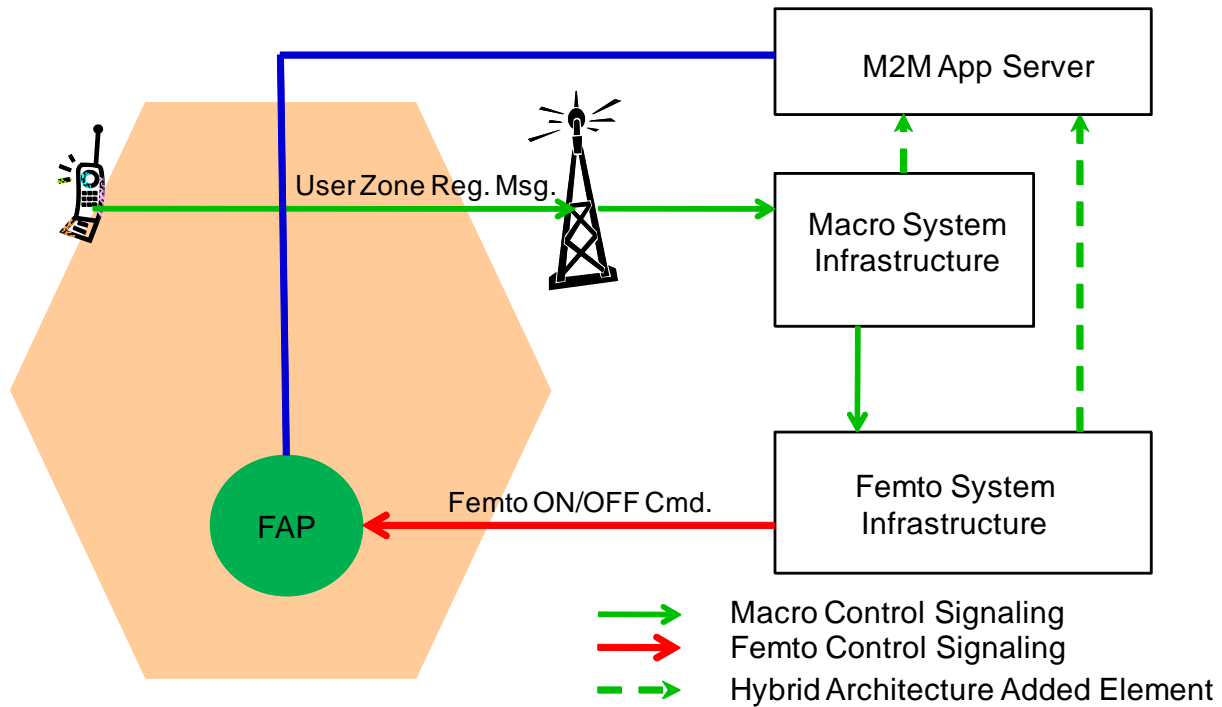

1  
2  
3  
4  
5  
6  
7  
8  
9  
10  
11

**Figure 4.5-5: Hybrid Architecture**

An added element in the hybrid architecture is signaling from the wireless operator’s infrastructure to the M2M application server, notifying it of UZRM reported events. Fig. 4.5-5 assumes M2M server “subscribing” to events occurring in the femtocell system infrastructure, in a fashion similar to what was described in Section 4.4.1.5.1. Alternatively, M2M server can subscribe directly to events occurring in the macro system infrastructure, in which case the green dotted line in the figure above would run between the Macro System Infrastructure and the M2M App Server.