

3GPP2 S.R0014

Version 1.0

Version Date: December 13, 1999



**3RD GENERATION
PARTNERSHIP
PROJECT 2
"3GPP2"**

Tandem Free Operation (Stage 1)

Revision: 0

COPYRIGHT

3GPP2 and its Organizational Partners claim copyright in this document and individual Organizational Partners may copyright and issue documents or standards publications in individual Organizational Partner's name based on this document. Requests for reproduction of this document should be directed to the 3GPP2 Secretariat at secretariat@3gpp2.org. Requests to reproduce individual Organizational Partner's documents should be directed to that Organizational Partner. See www.3gpp2.org for more information.

Revision History

Revision		Date
Rev. 0	Initial Publication	December 1999

1 **CONTENTS**

2

3 CONTENTS3

4 LIST OF FIGURES.....4

5 1 Introduction5

6 2. Terminology.....6

7 2.1 Acronyms 6

8 2.2 Definitions 6

9 3 Scope6

10 4. Tandem Free Operation requirements.....6

11 4.1 Mandatory Tandem Free Operation requirements..... 6

12 4.2 Highly Desired Tandem Free Operation requirements 9

13

LIST OF FIGURES

Figure 1 - Logical Diagram of the Speech Path for Digital Calls from Mobile A to Mobile B..... 5

1 Introduction

It is expected that the need for Tandem Free Operation will be driven by the increasing market penetration of digital technologies, which will result in an increase in the percentage of calls that are mobile-to-mobile calls. In addition, given that the effects of tandem vocoding are greater for lower bit rate vocoders, the need for this feature becomes greater as the use of low bit rate vocoders increases.

The Tandem Free Operation (TFO) feature, also known as Vocoder Bypass, improves the end-to-end voice quality observed in mobile-to-mobile voice calls in wireless networks.

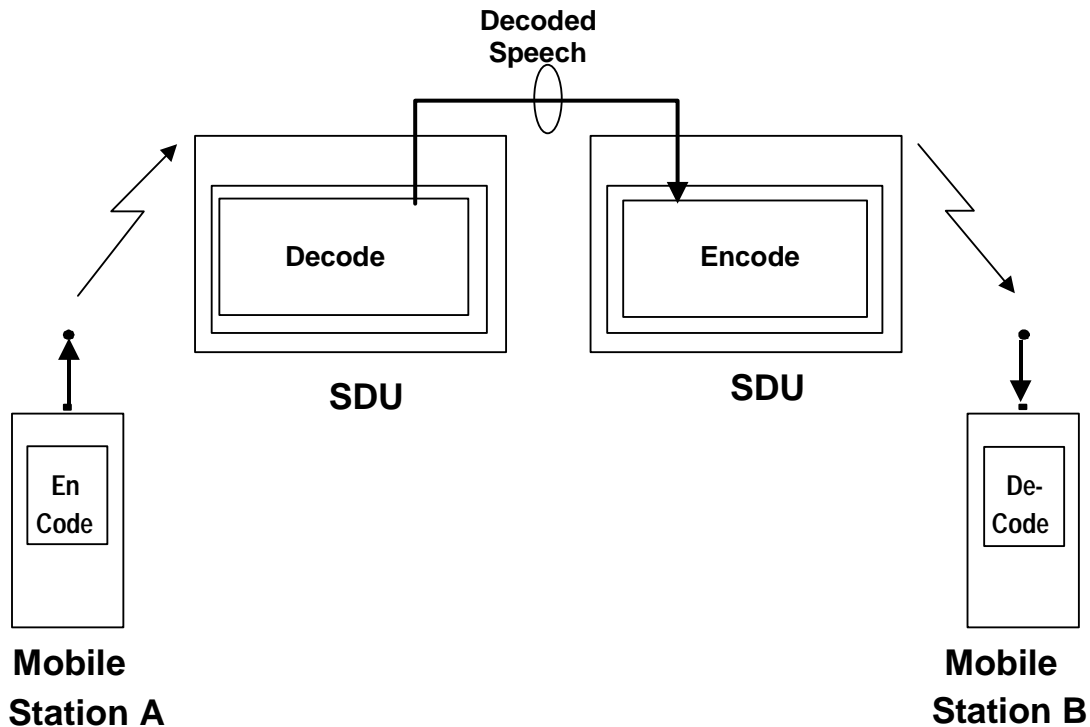

Figure 1 - Logical Diagram of the Speech Path for Digital Calls from Mobile A to Mobile B

Currently, there are four vocoders concatenated together on the call connection for a mobile-to-mobile call. See Figure 1. For example, the vocoder in mobile station A encodes the voice and sends it to SDU A. The vocoder in SDU A decodes the voice and sends it across the network to the vocoder in SDU B. The vocoder in SDU B encodes the voice and sends the encoded voice to the mobile station B where it is then decoded again. Each vocoder degrades the voice quality by introducing speech quantization errors that are inherent in any speech encoding and decoding process. Also each vocoding process introduces additional throughput delay.

The “Tandem Free Operation” feature will enhance current operation by bypassing the vocoding process at the SDUs for mobile to mobile calls. The encoded voice received from the BTS is not decoded at the SDU. Instead the encoded voice is transmitted transparently through the network. The encoded speech is routed to the appropriate SDU where it is converted back to the appropriate signaling format for routing to the BTS.

2. Terminology

2.1 Acronyms

BS	Base Station
BTS	Base Transceiver System
CDMA	Code Division Multiple Access
DS0	Digital Signal Level 0
DTMF	Dual Tone Multi-Frequency
GSM	Global System for Mobile Communication
MS	Mobile Station
MSC	Mobile Switching Center
PSTN	Public Switched Telephone Network
SDU	Selection/Distribution Unit
TDMA	Time Division Multiple Access
TFO	Tandem Free Operations
VoIP	Voice over IP

2.2 Definitions

2G	2nd generation wireless systems.
3G	3rd generation wireless systems.
Decoder	reconstruction of a speech signal from a compressed format according to an appropriate algorithm.
Encoder	compression of a speech signal into a new format for bandwidth efficiency according to an appropriate algorithm.
Mobile	a standalone unit communicating with the BTS over an air interface in a digital wireless communication system. In this document it is interpreted as a mobile station or a fixed wireless terminal.
SDU	a unit for housing the encoder and the decoder required for digital wireless transmission.

3 Scope

This document identifies the mandatory requirements and highly desirable requirements for TFO, which can be used as basis for development of a TFO standard.

4. Tandem Free Operation requirements

4.1 Mandatory Tandem Free Operation requirements

The TFO Feature shall:

1. Be established and maintained on successful communication between local and remote vocoders. The two bypass capable vocoders must be linked directly with a digital connection

- with no analog and digital processes such as digital loss pad or conference bridge between them.
2. Be transparent to both the mobile and land users and it should not have any operational impact on a regular mobile to land call.
 3. Support cdma2000 to cdma2000 mobile to mobile voice calls.
 4. Not prevent voice calls between any 2G or 3G systems regardless if TFO is implemented.
 5. Support TFO between two mobile stations that are on the same MSC.
 6. Support TFO between two mobile stations that are on different MSCs within the same operator's network. This includes calls which transit other networks but terminate on MSCs within the same operator's network.
 7. Support inter-MSC within two different operator's networks using a single technology, subject to other restrictions. This includes calls, which transit other networks but terminate on MSCs within the different operator's networks.
 8. Provide a solution that shall include the ability to inactivate echo cancelers while this feature is enabled, and activate echo cancelers while this feature is disabled. This feature shall not be enabled if echo canceler control is not possible.
 9. Not be impacted by nor impact soft handoff. (i.e., the two are independent).
 10. Support TFO both before and after hard handoff when the vocoder type is the same. Support disabling of TFO after hard handoff when the vocoder types are different.
 11. Support establishment of bypass mode following interruptions, such as supplementary service (e.g., 3-Way calling, etc.) and hard handoff.
 12. Not preclude inband or out-of-band transmission of DTMF. This feature may be temporarily disabled to support transmission of DTMF. This requirement shall not add new DTMF generation requirements.
 13. Not be restricted to mobile to mobile calls as long as conditions for TFO exist. For instance, either endpoint of a call may be a fixed wireless terminal.
 14. Provide a solution that is not required to be supported across an international gateway, for example, T1 to E1, A-law to mu-law.
 15. Provide a solution that shall be capable of functioning in a system that makes use of existing SS7 (ISUP) without impact to signaling and TIA/EIA-41 on the Network-Network interface.
 16. Be backwardly compatible in a 2G system, i.e., the solution shall function in 2G systems updated with this feature.
 17. Avoid impacts to SS7 (ISUP) signaling.
 18. Provide a solution that shall result in perceived voice quality equal to or better than that of the same call without the use of TFO.
 19. Provide a solution that shall have minimal impact on supplementary services, e.g., Call Forwarding, Call Waiting, 3-Way Calling. However, supplementary services shall take precedence over TFO.

20. Allow Lawfully Authorized Electronic Surveillance without degradation of perceived voice quality by the mobile station.
21. Not cause further degradation to perceived voice quality during bad frames compared to the same call without the use of TFO.
22. Not result in degradation to the perceived voice quality in the presence of link impairments (e.g., jitter, insertion of gain or loss padding) between the two speech processing units compared to the same call without use of TFO. This feature may be disabled under persistent link impairment conditions.
23. Support a system that automatically attempts to use TFO when all necessary conditions are met, and the network operator enables the feature. Specifically, the call must be a mobile to mobile voice call or fixed wireless call using the same vocoder type (algorithm) and no supplementary services prevent the use of TFO.
24. Avoid negative audible impacts on the perceived voice quality during transition to and from bypass mode, e.g., during call setup, during handoff, or at the start and stop of supplementary service activities.
25. Be able to be established within 2 seconds of stable call setup, i.e., a trunk has been established between the two SDUs that contains no echo cancelers or other disruptions
26. Allow TFO mode to be established for the active call during the use of Call Waiting when the criteria for bypass mode are met. That is, when the mobile station is connected to a second call as a result of call waiting or call transfer operations and the bypass mode criteria are met, then bypass mode shall be established.
27. Be capable of allowing the network operator to prevent the establishment of TFO, even if the conditions exist for bypass mode.
28. Support the ability of the network at either end of the call to reject establishment of TFO mode.
29. Provide support for the use of TFO calls between any 2G and 3G systems when compatible TFO implementations exist in those systems.
30. Support the following network configurations (assuming that other necessary conditions for TFO are met):
 - Intra-operator, intra-MSC and inter-MSC: direct trunks between MSCs or call delivery via PSTN.
 - Inter-operator: direct trunks between MSCs or call delivery via PSTN.
31. Is not required to work when the span types or companding (A-law / μ -law) are not in agreement.
32. Support transmission across both 64 Kbit/sec clear channels.
33. Allow for TFO operation following cellular network call forwarding to another mobile. (e.g. call forwarding no answer)
34. Require encoding and decoding processes internal to the speech handlers be reactivated on the completion of a mobile to mobile connection, or on the interruption of a clear digital channel between two TFO capable speech applications such as by a digital loss, handoff, conference bridge, etc.

4.2 Highly Desired Tandem Free Operation requirements

The TFO Feature may:

1. Provide support of calls other than cdma2000 to cdma2000 mobile to mobile calls, such as cdma2000 to GSM, TDMA, or Voice over IP (VoIP).
2. Minimize impacts to 2G systems to support TFO. (Example: networks using echo cancelers, gain/loss pad, or voice compression.)
3. Provide a solution that shall allow interoperability with the ETSI-GSM VB standard.
4. Provide a solution that shall allow compatibility with the voice over IP (VoIP) standards.
5. Provide for negotiation towards the use of a common vocoder for the duration of the call in order to establish TFO.
6. As part of the setup negotiation process should permit either end of the system to transcode directly from one vocoder to another. When transcoding is employed, the system using it shall identify to the other end the type of transcoding in use, thus eliminating one of the two intermediate transcoders when different vocoders at the mobiles were unavoidable.
7. Minimize the impact on standards and functions other than those related to speech processing.
8. Support an ATM based interface to permit direct MSC to MSC and BSC to BSC transmission of vocoder frames, thereby reducing the bandwidth requirements between serving systems.
9. Provide benefits by reducing delay. As networks continue to evolve and additional vocoders are introduced, it can be anticipated that a need for vocoder transcoding will be increasingly important. Transacting support will allow, where capable, a network to transact directly between two vocoders without the need to convert to PCM first. While not providing as much benefit as vocoder bypass on the identical vocoders, it will provide benefits by reducing delay and some artifacts.