

*3GPP2 S.R0003*

*Version 1.0.0*

*Date: January 20, 2000*



**3RD GENERATION  
PARTNERSHIP  
PROJECT 2  
"3GPP2"**

---

1

2 **3GPP2 System Capability Guide**

3 **Release A**

4

**COPYRIGHT**

3GPP2 and its Organizational Partners claim copyright in this document and individual Organizational Partners may copyright and issue documents or standards publications in individual Organizational Partner's name based on this document. Requests for reproduction of this document should be directed to the 3GPP2 Secretariat at [secretariat@3gpp2.org](mailto:secretariat@3gpp2.org). Requests to reproduce individual Organizational Partner's documents should be directed to that Organizational Partner. See [www.3gpp2.org](http://www.3gpp2.org) for more information.

1

## 2 Revision History

3

<u>Revision</u>	<u>Description</u>	<u>Date</u>
Version 1.0.0	Initial Publication	January 20, 2000

4

1  
2

TABLE OF CONTENTS

LIST OF FIGURES	5
INTRODUCTION	7
• •DOCUMENT PURPOSE	7
• •DOCUMENT OVERVIEW	7
• •DOCUMENT APPLICABILITY	7
• •DOCUMENT REFERENCES	8
3GPP2 OVERVIEW AND BACKGROUND	9
3GPP2 SYSTEM OVERVIEW	12
• •3GPP2 RELEASE A OBJECTIVES	13
• •3GPP2 NETWORK BASIS	15
• •3GPP2 NETWORK ARCHITECTURE	16
• •3GPP2 AIR INTERFACE SIGNALING LAYERS	18
3GPP2 AIR INTERFACE	23
• •PHYSICAL LAYER	23
• •VOCODER CAPABILITIES	28
• •LOGICAL CHANNELS	29
• •MAC LAYER CAPABILITIES	30
• •LAC LAYER CAPABILITIES	31
• •LAYER 3 SIGNALING CAPABILITIES	33
3GPP2 RADIO ACCESS NETWORK INTERFACE	34
3GPP2 INTERSYSTEM INTERFACE	36
3GPP2 SYSTEM FEATURES	37
3GPP2 DATA SERVICES	39
• •CIRCUIT DATA	41
• •PACKET DATA	42
3GPP2 SYSTEM SERVICES	42
ANALOG OPERATIONS	43
APPENDIX	46
• •3GPP2 DOCUMENT REFERENCE LISTING	47
• •AIR INTERFACE PARAMETER ADMINISTRATION	50

1

## LIST OF FIGURES

2

Figure 1: 3GPP2 ORGANIZATIONAL STRUCTURE	12
Figure 2: 3GPP2 NETWORK REFERENCE MODEL	17
Figure 3: AIR INTERFACE - SIMPLIFIED LAYERING DIAGRAM	18
Figure 4: AIR INTERFACE - GENERAL ARCHITECTURE	19
Figure 5: 3GPP2 AIR INTERFACE CONTROL AND DATA PLANES	21

3

1 INTRODUCTION

2 This document is the 3GPP2 System Capability Guide (SCG) for 3GPP2 wireless  
3 telecommunication systems. It is developed and maintained under the  
4 auspices of 3GPP2 TSG-S, the TSG for Services and Systems Aspects for  
5 3GPP2.

6 • DOCUMENT PURPOSE

7 This objective of this document is to provide an overview for and  
8 reference to the 3GPP2 wireless telecommunication system capabilities,  
9 features, and services. This document is intended for use by persons  
10 and/or companies who are developing and/or deploying 3GPP2 wireless  
11 telecommunication systems or by persons who are otherwise interested  
12 in 3GPP2 wireless telecommunication systems.

13 • DOCUMENT OVERVIEW

14 This document includes the following sections:

- 15 ▪ INTRODUCTION AND 3GPP2 SYSTEM OVERVIEW
- 16 ▪ cdma2000 AIR INTERFACE CAPABILITIES
  - 17 • PHYSICAL LAYER SIGNALING
  - 18 • MAC LAYER SIGNALING
  - 19 • LAC LAYER SIGNALING
  - 20 • LAYER 3 SIGNALING
- 21 ▪ ACCESS NETWORK CAPABILITIES
- 22 ▪ INTERSYSTEM CAPABILITIES
- 23 ▪ OTHER 3GPP2 SYSTEM FEATURES
- 24 ▪ DATA SERVICES
  - 25 • CIRCUIT DATA
  - 26 • PACKET DATA
- 27 ▪ 3GPP2 SYSTEM SERVICES
- 28 ▪ ANALOG AIR INTERFACE OPERATIONS AND CAPABILITIES
- 29 ▪ ACRONYM LISTING AND CROSS REFERENCE

30 • DOCUMENT APPLICABILITY

31 This document is applicable to the 3GPP2 wireless telecommunications  
32 system Release A. However, this document may also include references  
33 to previously issued standards and specifications.

1 • DOCUMENT REFERENCES

2 This document references all 3GPP2 specifications and reports based on  
3 the 3GPP2 Document Reference Listing which is included in the  
4 Appendix of this document. All documents included in that list are also  
5 considered implicit references for this SCG document.

6 The 3GPP2 Service Implementation Guide (SIG) is a companion  
7 document to this SCG document which details the use of existing 3GPP2  
8 signaling to implement new system services. That document is  
9 referenced in the 3GPP2 SYSTEM SERVICES section of this document

## 1 3GPP2 OVERVIEW AND BACKGROUND

2 The 3GPP2 (3rd Generation Partnership Project 2) is a partnership of standards  
3 development organizations (SDOs). The 3GPP2 Organizational Partners  
4 include, along with their regional areas of interest, the following SDOs:

ORGANIZATIONAL PARTNER		REGIONAL AREA OF INTEREST
ARIB	Association of Radio Industries and Business	Japan
CWTS	China Wireless Telecommunication Standard Group	China
TTA	Telecommunications Technology Association	Korea
TTC	Telecommunication Technology Committee	Japan
TIA	Telecommunications Industry Association	NAFTA countries including USA, Canada, and Mexico

5 3GPP2 is an effort spearheaded by the original four (4) Organizational Partners  
6 (i.e., ARIB, TTA, TTC, and TIA) to establish a Partnership Project for the 3G  
7 wireless communication systems using evolved ANSI/TIA/EIA-41, "Cellular  
8 Radio telecommunication Intersystem Operations" networks and related RTTs.  
9 This effort was initiated in response to concerns regarding ETSI's unwillingness  
10 to include non-GSM technologies in their proposal for the establishment of the  
11 3G Partnership Project (3GPP). The inaugural meeting of the 3GPP2 Steering  
12 Committee was held in January 1999 in Vancouver, BC where the partnership  
13 documents and working procedures were also officially agreed. CWTS's  
14 application for membership as an Organizational Partner was officially  
15 accepted in June 1999 in Seoul, Korea.

16 Participating SDOs have the right to submit 3GPP2 technical specifications for  
17 approval and publication as standards, or parts of standards within their home  
18 national or regional processes. This partnership project is a new way of  
19 working among the existing organizations. It addresses the industry's need to  
20 produce globally applicable specifications without altering the national or  
21 regional scope of existing standards organizations.

22 The Technical Specification Groups (TSGs) currently formed within 3GPP2 for  
23 specifying Release A are the following:

- 24 • TSG-A Access Network Interface
  - 25 ▪ Physical links, transports and signaling
  - 26 ▪ Support for access network mobility
  - 27 ▪ 3G Capabilities (e.g. High speed data support)
  - 28 ▪ Abis interface
  - 29 ▪ Interoperability Specification
  - 30 ▪ Support for 3GPP2 Radio Access Technologies

- 1 • TSG-C cdma2000
  - 2 ▪ Radio Layer 1 specification
  - 3 ▪ Radio Layer 2 specification
  - 4 ▪ Radio Layer 3 specification
  - 5 ▪ MS/BS Radio Performance Specifications
  - 6 ▪ Radio Link Protocol
  - 7 ▪ Support for enhanced privacy, authentication and encryption
  - 8 ▪ Digital Speech Codecs
  - 9 ▪ Video Codec adoption
  - 10 ▪ Data and Other Ancillary Services support
  - 11 ▪ Conformance Test Plans
  - 12 ▪ MS-Adapter Interface
- 13 • TSG-N ANSI-41/WIN
  - 14 ▪ Evolution of Core Network for Inter System Operation within the
  - 15 ANSI-41 Family member
  - 16 ▪ UIM support (Detachable and Integrated)
  - 17 ▪ Support for enhanced privacy, authentication, encryption and
  - 18 other security aspects.
  - 19 ▪ VHE (Virtual Home Environment)
  - 20 ▪ Support of New Supplemental Services (including ISDN
  - 21 interworking)
  - 22 ▪ Optimal Interoperability Specification for International Roaming
  - 23 (e.g. Selection of required parameters options)
  - 24 ▪ New Features for International Roaming (Global Emergency
  - 25 Number, Optimal Routing)
  - 26 ▪ IMT-2000 issues as necessary to ensure support of the ANSI-41
  - 27 family member
- 28 • TSG-P Wireless Packet Data Networking
  - 29 ▪ Wireless IP Services (including IP Mobility Management)
  - 30 ▪ Wireless IP network architecture design
  - 31 ▪ Voice over IP
  - 32 ▪ Secure Private Network Access
  - 33 ▪ Internet Access
  - 34 ▪ Packet Data Accounting
  - 35 ▪ Multimedia Support
  - 36 ▪ QoS Support

- 1 • TSG-R Interface of 3GPP Radio Access Technology to 3G Core  
2 Network evolved from ANSI-41
  - 3 ▪ Interface to accommodate evolving UTRA features which may  
4 include WP-CDMA and other features as determined by 3GPP
  - 5 ▪ Minimal enhancements/ modifications of UTRA radio technology, if  
6 necessary, to accommodate ANSI-41 Core Network.
  - 7 ▪ Support handoff between existing cdmaOne (2G) and UTRA radio  
8 technology (both intersystem and intrasystem handoff)
  - 9 ▪ Roaming issues for UTRA handset between GSM core network and  
10 ANSI-41 core network
  - 11 ▪ User terminal equipment and infrastructure for the above
  - 12 ▪ Liaison or joint work efforts, as appropriate, with other 3G groups.
- 13 • TSG-S Services and Systems Aspects
  - 14 ▪ System Capability Set Development
  - 15 ▪ Stage 1 Feature and Service Requirements Definition
  - 16 ▪ System Reference Model Development and Maintenance
  - 17 ▪ Requirements for International Roaming.
  - 18 ▪ Definition of Stage 1 high level requirements for OAM&P across all  
19 TSGs.
  - 20 ▪ High level coordination of the work performed in other TSGs and  
21 monitoring of progress.

1 The organizational structure of 3GPP2 is illustrated in Figure 1 below:

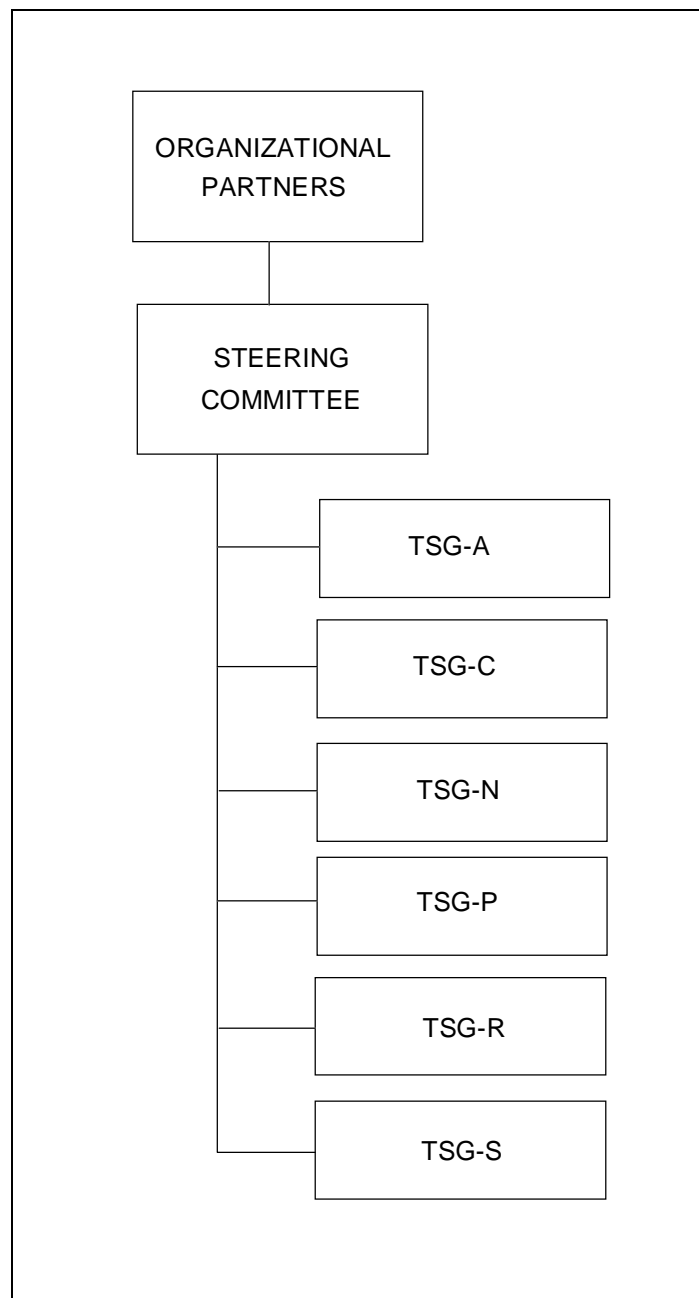

2 **Figure 1: 3GPP2 ORGANIZATIONAL STRUCTURE**

3

4 **NOTE:** Additional and more detailed information on 3GPP2 may be obtained at  
5 <http://www.3gpp2.org>.

1  
2  
3  
4  
5  
6  
7  
8  
9  
10  
11  
12  
13  
14  
15  
16  
17  
18  
19  
20  
21  
22  
23  
24  
25  
26  
27  
28  
29  
30  
31  
32  
33  
34

## 3GPP2 SYSTEM OVERVIEW

The 3GPP2 wireless telecommunication system is a third generation (3G) wireless telecommunication system which was designed based on requirements proposed by the International Telecommunications Union (ITU) in their IMT-2000 initiative.

The 3GPP2 air interface (cdma2000) is a wideband spread spectrum radio interface that utilizes CDMA technology in order to meet the needs of the third generation (3G) wireless communication systems and to meet the requirements for the 3G evolution of the current TIA/EIA-95-B family of standards.

- **3GPP2 RELEASE A OBJECTIVES**

TIA/EIA-IS-2000 was the first 3G system standard published in the world. Basic design objectives of the 3GPP2 Release A system as enhanced from that TIA/EIA-IS-2000 standard are indicated below:

- **CORE CAPABILITY ENHANCEMENTS**

- Complete 1X/3X Upper Layer Support
- Complete 3X Physical Layer Support
- Add Packet Data Support up to a minimum of 384 kbps
- Add Circuit Data Support up to a minimum of 64 kbps
- Add MAC and Non-Transparent RLP for Packet Data Services up to a minimum of 384 kbps
- Add MAC and Non-Transparent RLP for Circuit Data Services up to a minimum of 64 kbps
- Add Enhanced System Access Procedures
- Add Voice and Packet Data Concurrent Support
- Add Direct Spread (DS) and Multi-Carrier (MC) Support
- Add Quality of Service (QoS) Support
  - QoS Negotiation - Start of Call
  - QoS Parameters - Initial list

NOTE: Release A does not include QoS negotiation during a call.

- Add Ability to Select and Invoke Enhanced and Alternative Privacy and Encryption algorithms
- Add Ability to Select and Invoke Enhanced and Alternative Authentication algorithms and schemes

- 1       ▪     Add Support for Handoff between different carrier sizes and  
2       structures (e.g. Soft, Hard, 1x-3x, DS to MC, Inter-generation)
- 3       ▪     Add “hooks” to support MC and DS implementations which are  
4       globally harmonized.

5

6     •     **SERVICE ADDITIONS/ENHANCEMENTS**

- 7       ▪     OTASP/OTAPA Updates
- 8       ▪     Global Emergency Number Support
- 9       ▪     Broadcast Teleservice Transport Categories
- 10      ▪     Circuit Data - ISDN Interworking Support
- 11      ▪     Circuit Data - V.90 Interworking Support
- 12      ▪     Advice of Charge
- 13      ▪     Multiple Character Set Support
- 14      ▪     Feature Activation/De-Activation Messages
- 15      ▪     User Identity Module (UIM) Support including support for  
16      Removable UIM (R-UIM) including UIM-MT (UIM Mobile Terminal)  
17      interface
- 18      ▪     Location Services Support including support for compliance with  
19      U.S. FCC E911 mandate

20

21    •     **Standing SYSTEM Requirements**

- 22      ▪     Increased Battery Life for the Mobile
- 23      ▪     Full Support of cdma2000 Phase 1 Systems (TIA/EIA-95-B and IS-  
24      2000)
- 25      ▪     Physical Layer Optimization and Signaling Layer Support

26

27    NOTE: 3GPP2 Release A supports the following FDD modes:

- 28      ▪     1xRTT
- 29      ▪     MC (multi-carrier, 3xRTT)

30       Support for the TDD and FDD DS modes will be added in a future  
31       release.

32    NOTE: All references to DS in this document refer to the direct spread mode  
33    which has been harmonized between 3GPP and 3GPP2 (DS-41).

1 Additional details on the 3GPP2 wireless telecommunications system are  
 2 indicated below:

3 • **3GPP2 NETWORK BASIS**

4 In general, the 3GPP2 system is defined by the operation of three (3)  
 5 primary system interfaces as listed below:

- 6 ▪ AIR INTERFACE
- 7 ▪ RADIO ACCESS INTERFACE (i.e., A-INTERFACE)
- 8 ▪ INTERSYSTEM INTERFACE

9 The basis of the 3GPP2 wireless telecommunications system is  
 10 summarized as follows:

- 11 ▪ Intersystem interface and network architecture are based on ANSI-  
 12 41.
- 13 ▪ Radio access interface is based on the InterOperability System  
 14 (IOS) standard. Compliance 3GPP2 A.S-0001 is required for full  
 15 support of all applicable capabilities, features, and services listed  
 16 herein.
- 17 ▪ Air interface is based on enhanced cdma2000 and is designed as  
 18 follows:

19 • **BAND CLASS DESIGNATORS**

BAND CLASS DESIGNATOR	BAND
0	NORTH AMERICAN CELLULAR BAND
1	NORTH AMERICAN PCS BAND
2	TACS BAND
3	JTACS BAND
4	KOREAN PCS BAND
5	NMT-450 BAND
6	IMT-2000 BAND

20

- **BAND CLASS FREQUENCY BANDS**

- **NORTH AMERICAN CELLULAR BAND**

System Designator	Transmit Frequency Band (MHz)	
	Mobile Station	Base Station
A	824.025-835.005 844.995-846.495	869.025-880.005 889.995-891.495
B	835.005-844.995 846.495-848.985	880.005-889.995 891.495-893.985

- **NORTH AMERICAN PCS BAND**

Block Designator	Transmit Frequency Band (MHz)	
	Mobile Station	Base Station
A	1850-1865	1930-1945
D	1865-1870	1945-1950
B	1870-1885	1950-1965
E	1885-1890	1965-1970
F	1890-1895	1970-1975
C	1895-1910	1975-1990

- **OTHER BANDS**

Band Class Value (Binary)	Frequency Band	Associated Standards
00000	800 MHz Cellular System	TIA/EIA-95-B
00001	1.850 to 1.990 GHz Broadband PCS	TIA/EIA-95-B
00010	872 to 960 MHz TACS Band	None
00011	832 to 925 MHz JTACS Band	ARIB STD-T53
00100	1.750 to 1.870 GHz Korean PCS	TTA.KO-006.0013
00101	450 MHz NMT	None
00110	2 GHz IMT-2000 Band	TIA/EIA/IS-2000
00111 -11111	Reserved	None

1  
2  
3  
4  
5  
6  
7  
8  
9  
10  
11  
12  
13  
14  
15  
16  
17

- **PHYSICAL CHANNELS**
  - **1.25 MHz SINGLE CHANNEL**
  - **3x MULTI-CARRIER CHANNEL (MC)**
- **OTHER BASIC CAPABILITIES**
  - **SUPPORTS 2G MOBILES**
  - **SUPPORT HANDOFF BETWEEN 2G/3G SYSTEMS AND BETWEEN 3G CHANNELS**

Compliance with 3GPP2 C.S0001 through C.S0006 is required for full support of all applicable capabilities, features, and services listed herein.

- **3GPP2 NETWORK ARCHITECTURE**

The 3GPP2 Network Reference Model (NRM) is illustrated in Figure 2. It is described in substantially more detail in the 3GPP2 Network Reference Model document (3GPP2 S.R0005-A). Compliance with 3GPP2 S.R0005-A is required for full support of all applicable capabilities, features, and services listed herein.

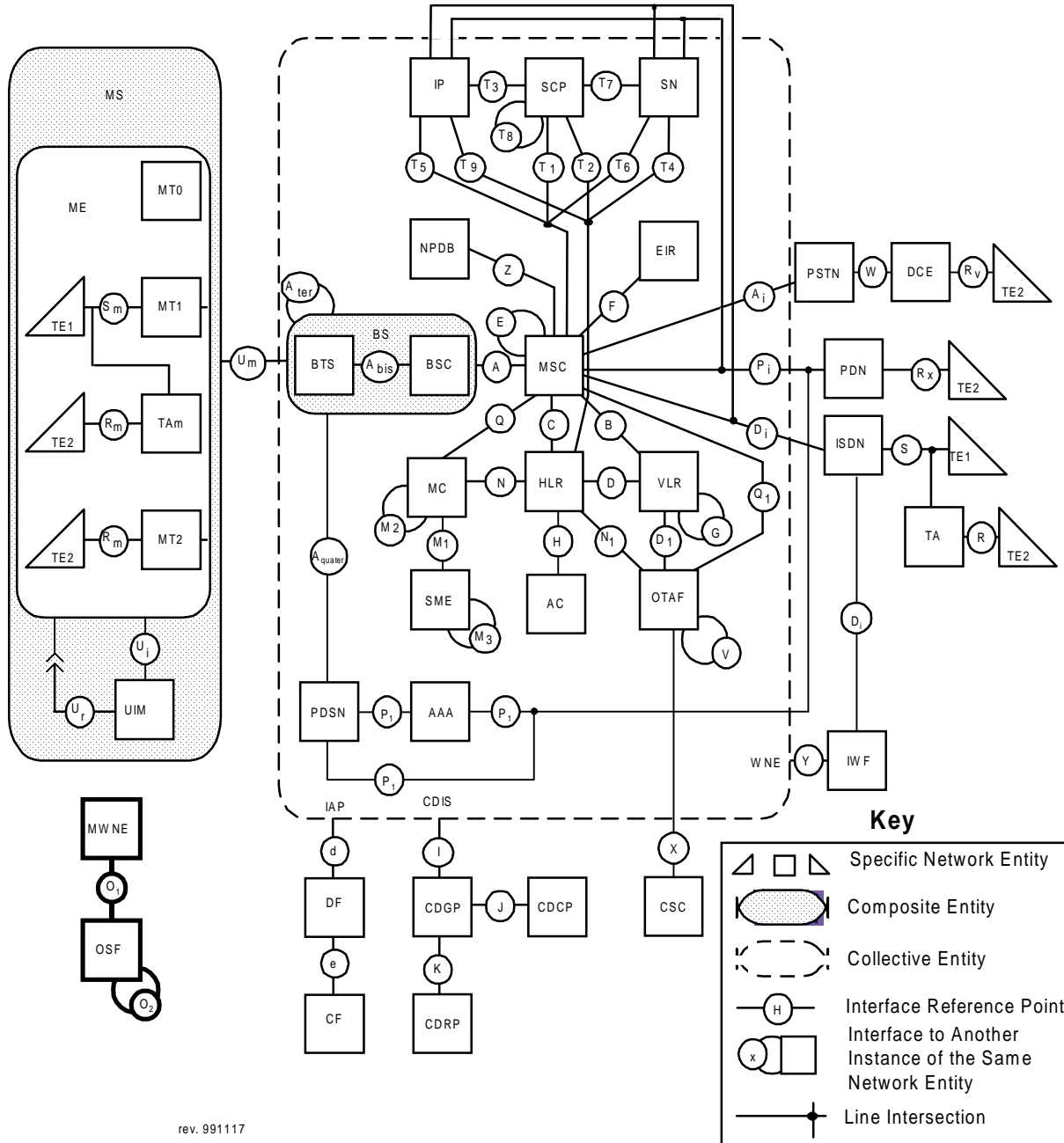

rev. 991117

1  
2  
3

Figure 2: 3GPP2 NETWORK REFERENCE MODEL

1 • **3GPP2 AIR INTERFACE SIGNALING LAYERS**

2 The air interface of 3GPP2 systems has been developed based on the  
 3 ISO/OSI Reference Model layering requirements. The 3GPP2 layer  
 4 structure is illustrated below in Figure 3:

5

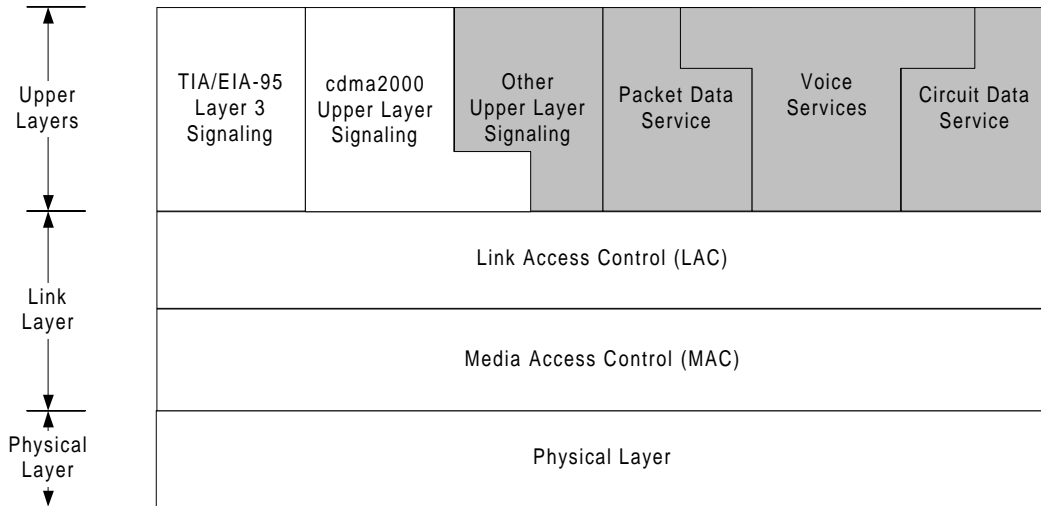

6

7 **Figure 3: AIR INTERFACE - SIMPLIFIED LAYERING DIAGRAM**

1 A more detailed architectural diagram is detailed in Figure 4 below:

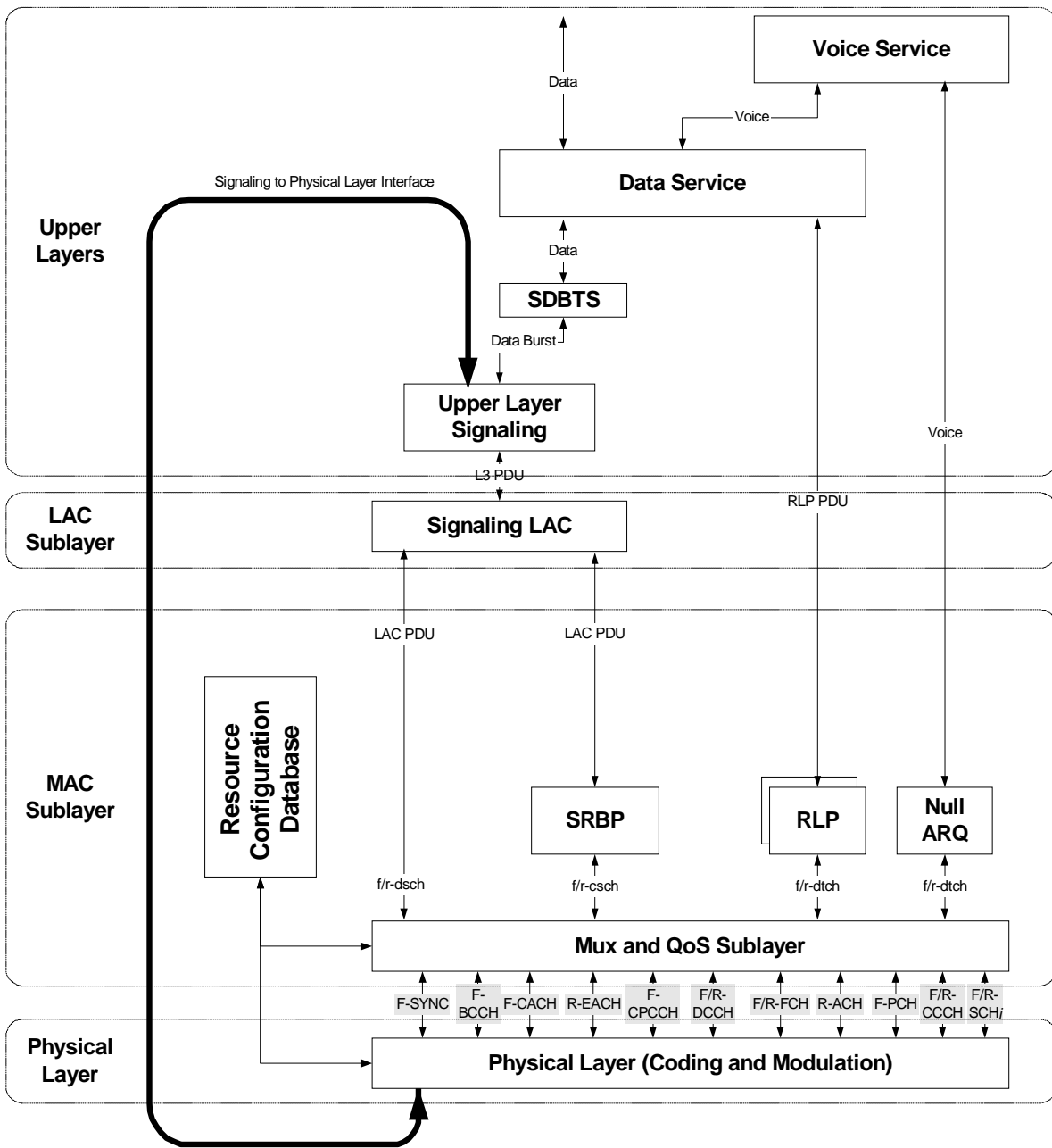

2  
3 Figure 4: AIR INTERFACE - GENERAL ARCHITECTURE

4 NOTE: An explanation of the terms used in Figure 2 may be obtained from the  
5 "TIA Subcommittee TR-45.5 Final Inputs for the Draft IMT.RSPC Section 5" at  
6 <http://www.itu.int/itudoc/itu-r/sg8/docs/tg8-1/1998-99/18th/index.html> .  
7 However, an ITU-R TIES password is required for access.

1 Definitions of the 3GPP2 air interface layers are indicated below:

- 2     ▪     **PHYSICAL LAYER:** Supports actual transmission and reception of  
3 signals between the mobile station and the base station including  
4 frequency selection with appropriate modulation and demodulation  
5 operations. The Physical Layer supports RF channel bandwidths  
6 of  $N \times 1.25$  MHz, where N is the Spreading Rate number and  $N = 1$   
7 and 3. The data rates, channel encoding, and modulation pa-  
8 rameters supported on the Traffic Channels are specified by radio  
9 configurations. For Spreading Rates 1 and 3, there are six radio  
10 configurations for the reverse link and there are nine radio con-  
11 figurations for the forward link. Collectively, these radio configu-  
12 rations form the FDD MC-CDMA 1X and 3X. Spreading Rate 1  
13 corresponds to 1X. Spreading Rate 3 corresponds to 3X. Radio  
14 Configurations 1 and 2 are specified to be backward compatible  
15 with TIA/EIA-95-B systems. The 3GPP2 air interface also supports  
16 a class of operational band plans as specified in the TIA/EIA/IS-  
17 2000 standard. The Physical Layer signaling corresponds to  
18 ISO/OSI Reference Model physical layer (i.e., layer 1).
- 19     ▪     **MEDIA ACCESS CONTROL (MAC) LAYER:** Supports multiple  
20 data service state machine instances, one for each active packet or  
21 circuit data service instance, with applicable QoS mechanisms on  
22 each. This layer supports the complex multi-media multi-service  
23 capabilities which are targeted for 3G wireless systems. The MAC  
24 Layer signaling corresponds to the “lower” portion (i.e., interface to  
25 the Physical Layer) of the ISO/OSI Reference Model Link Layer (i.e.,  
26 layer 2). The MAC services are considered to be null when encoded  
27 voice data is transported directly by the Physical Layer (i.e.,  
28 backward compatible with TAI/EIA-95-B). NOTE: The MAC Layer  
29 for 3GPP2 Release A includes support for one (1) voice and/or one  
30 (1) packet data service (data rates up to 144 kbps) instance. The  
31 full multi-media call model will be supported in a future MAC  
32 Layer release.
- 33     ▪     **LINK ACCESS CONTROL (LAC) LAYER:** Supports point-to-point  
34 transmission over the air for signaling services and (optionally) for  
35 circuit data services. The LAC Layer also provides the framework  
36 and services to transport encoded voice data in the form of packet  
37 data or circuit data traffic as a part of a multimedia call. The LAC  
38 Layer signaling corresponds to the “upper” portion (i.e., interface to  
39 the MAC Layer) of the ISO/OSI Reference Model Link Layer (i.e.,  
40 layer 2). The LAC services are considered to be null when encoded  
41 voice data is transported directly by the Physical Layer (i.e.,  
42 backward compatible with TAI/EIA-95-B).

- 1     ▪     **LAYER 3 SIGNALING:** Supports all other application and upper  
2     layer protocols (e.g. Signaling Services, Voice Services, Data Serv-  
3     ices (Packet Data and Circuit Data)). Layer 3 signaling  
4     corresponds to layers 3 and above as appropriate of the ISO/OSI  
5     Reference Model.
  
- 6     ▪     The 3GPP2 layering structure is composed of two (2) separate  
7     planes: the Control Plane and the Data Plane. The principal  
8     advantage of this structuring is the clear definition of the service  
9     interfaces between all of the functional entities described by the  
10    cdma2000 layering structure. The major functional blocks of the  
11    Control and Data Planes are depicted in Figure 5.

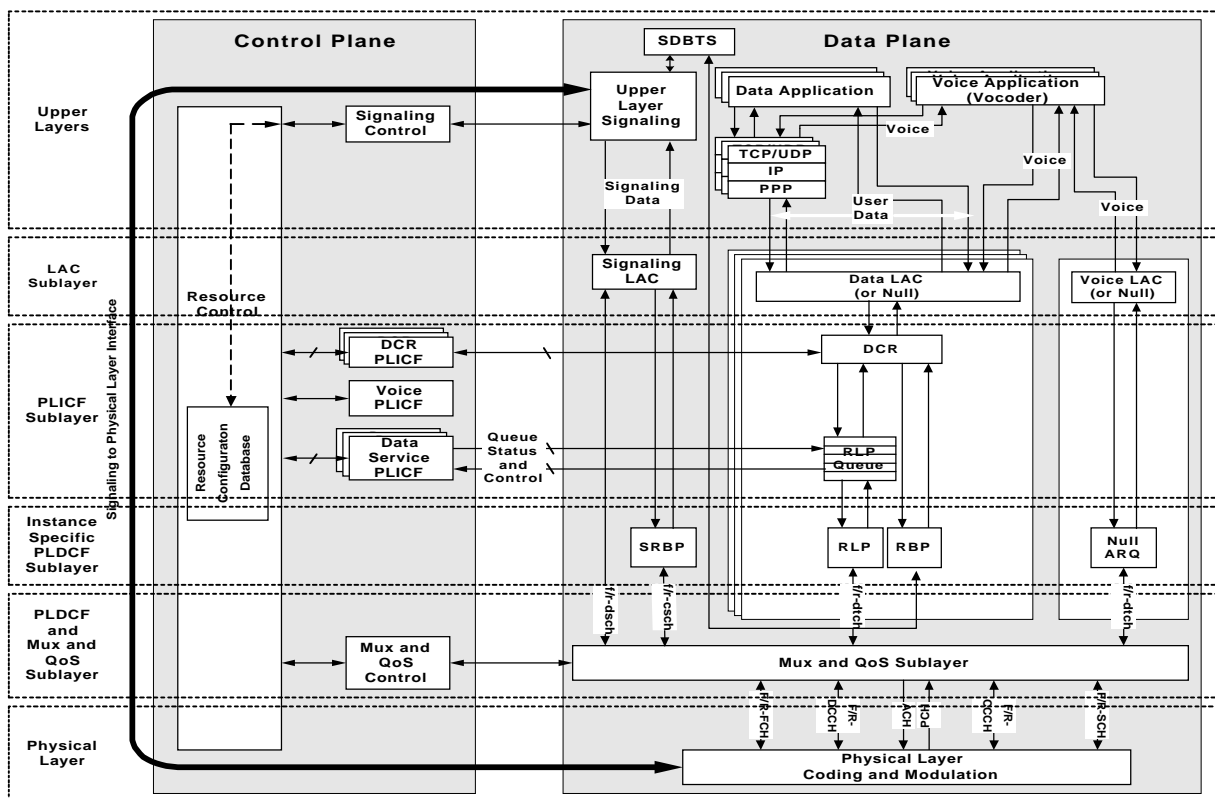

Figure 5: 3GPP2 AIR INTERFACE CONTROL AND DATA PLANES

NOTE: This air interface layering applies to CDMA modes only. It does not apply to dual-mode phones operating in analog mode.

NOTE: Additional and more detailed technical information on the 3GPP2 air interface (cdma2000) may be obtained from the TIA Subcommittee TR-45.5 Final Inputs for the Draft IMT.RSPC Section 5 at <http://www.itu.int/itudoc/itu-r/sg8/docs/tg8-1/1998-99/18th/index.html>. However, an ITU-R TIES password is required for access.



1 3GPP2 AIR INTERFACE

2 This section details the capabilities and features of the 3GPP2 air interface (cdma2000).

3 • PHYSICAL LAYER

4 The following are general physical layer capabilities of the 3GPP2 system.

CAPABILITY/FEATURE	CATEGORY	ACRONYM	REFERENCE
BAND CLASS	BAND CLASS 0		C.S0002 Section 2.1.1.1.1 C.S0002-A Section 2.1.1.1.1
	BAND CLASS 1		C.S0002 Section 2.1.1.1.2 C.S0002-A Section 2.1.1.1.2
	BAND CLASS 2		C.S0002-A Section 2.1.1.1.3
	BAND CLASS 3		C.S0002-A Section 2.1.1.1.4
	BAND CLASS 4		C.S0002-A Section 2.1.1.1.5
	BAND CLASS 5		C.S0002-A Section 2.1.1.1.6
	BAND CLASS 6		C.S0002-A Section 2.1.1.1.7
CDMA SYSTEM TIME			C.S0002 Section 1.3 C.S0002-A Section 1.3
LOGICAL CHANNEL NAMING CONVENTION			C.S0001 Section 2.2.1 C.S0001-A Section 2.2.1
CDMA CHANNEL MODULATION	FORWARD CDMA CHANNELS		C.S0002 Section 3.1.3.1 C.S0002-A Section 3.1.3.1
	REVERSE CDMA CHANNELS		C.S0002 Section 2.1.3.1 C.S0002-A Section 2.1.3.1

1

PHYSICAL CHANNELS	ACCESS CHANNEL	R-ACH	C.S0002 Section 2.1.3.3 C.S0002-A Section 2.1.3.3
	BROADCAST CHANNEL	F-BCH	C.S0002 Section 3.1.3.5 C.S0002-A Section 3.1.3.5
	COMMON POWER CONTROL CHANNEL	F-CPCCH	C.S0002 Section 3.1.3.7 C.S0002-A Section 3.1.3.7
	COMMON ASSIGNMENT CHANNEL	F-CACH	C.S0002 Section 3.1.3.8 C.S0002-A Section 3.1.3.8
	ENHANCED ACCESS CHANNEL	R-EACH	C.S0002 Section 2.1.3.4 C.S0002-A Section 2.1.3.4
	FORWARD COMMON CONTROL CHANNEL	F-CCCH	C.S0002 Section 3.1.3.9 C.S0002-A Section 3.1.3.9
	FORWARD DEDICATED CONTROL CHANNEL	F-DCCH	C.S0002 Section 3.1.3.10 C.S0002-A Section 3.1.3.10
	FORWARD FUNDAMENTAL CHANNEL	F-FCH	C.S0002 Section 3.1.3.11 C.S0002-A Section 3.1.3.11
	FORWARD SUPPLEMENTAL CHANNEL	F-SCH	C.S0002 Section 3.1.3.12 C.S0002-A Section 3.1.3.12
	FORWARD SUPPLEMENTAL CODE CHANNEL	F-SCCH	C.S0002 Section 3.1.3.13 C.S0002-A Section 3.1.3.13
	PAGING CHANNEL	F-PCH	C.S0002 Section 3.1.3.4 C.S0002-A Section 3.1.3.4
	PILOT CHANNELS	F-PICH	C.S0002 Section 3.1.3.2 C.S0002-A Section 3.1.3.2
	QUICK PAGING CHANNEL	F-QPCH	C.S0002 Section 3.1.3.6 C.S0002-A Section 3.1.3.6
REVERSE PILOT CHANNEL	R-PICH	C.S0002 Section 2.1.3.2 C.S0002-A Section 2.1.3.2	

REVERSE COMMON CONTROL CHANNEL	R-CCCH	C.S0002 Section 2.1.3.5 C.S0002-A Section 2.1.3.5
REVERSE DEDICATED CONTROL CHANNEL	R-DCCH	C.S0002 Section 2.1.3.6 C.S0002-A Section 2.1.3.6
REVERSE FUNDAMENTAL CHANNEL	R-FCH	C.S0002 Section 2.1.3.7 C.S0002-A Section 2.1.3.7
REVERSE POWER CONTROL SUBCHANNEL		C.S0002 Section 2.3.1.10
REVERSE SUPPLEMENTAL CHANNEL	R-SCH	C.S0002 Section 2.1.3.8 C.S0002-A Section 2.1.3.8
REVERSE SUPPLEMENTAL CODE CHANNEL	R-SCCH	C.S0002 Section 2.1.3.9 C.S0002-A Section 2.1.3.9
SYNC CHANNEL	F-SYNCH	C.S0002 Section 3.1.3.3 C.S0002-A Section 3.1.3.3

1 The following are mobile station capabilities which are supported by the 3GPP2 system.

CAPABILITY/FEATURE	CATEGORY	ACRONYM	REFERENCE
MINIMUM PERFORMANCE REQUIREMENTS			C.S0011
TRANSMITTER	FREQUENCY PARAMETERS		C.S0002 Section 2.1.1 C.S0002-A Section 2.1.1
	OUTPUT POWER CHARACTERISTICS		C.S0002 Section 2.1.2 C.S0002-A Section 2.1.2
	MODULATION CHARACTERISTICS		C.S0002 Section 2.1.3 C.S0002-A Section 2.1.3
	LIMITATIONS ON EMISSIONS		C.S0002 Section 2.1.4 C.S0002-A Section 2.1.4
	SYNCHRONIZATION AND TIMING		C.S0002 Section 2.1.5 C.S0002-A Section 2.1.5
	TRANSMITTER PERFORMANCE REQUIREMENTS		C.S0002 Section 2.1.6 C.S0002-A Section 2.1.6
RECEIVER	CHANNEL SPACING AND DESIGNATION		C.S0002 Section 2.2.1 C.S0002-A Section 2.2.1
	DEMODULATION CHARACTERISTICS		C.S0002 Section 2.2.2 C.S0002-A Section 2.2.2
	LIMITATIONS ON EMISSIONS		C.S0002 Section 2.2.3 C.S0002-A Section 2.2.3
	MALFUNCTION DETECTION		C.S0002 Section 2.2.4 C.S0002-A Section 2.2.4

2

1 The following are base station capabilities which are supported by the 3GPP2 system.

CAPABILITY/FEATURE	CATEGORY	ACRONYM	REFERENCE
MINIMUM PERFORMANCE REQUIREMENTS			C.S0010
TRANSMITTER	FREQUENCY PARAMETERS		C.S0002 Section 3.1.1 C.S0002-A Section 3.1.1
	OUTPUT POWER CHARACTERISTICS		C.S0002 Section 3.1.2 C.S0002-A Section 3.1.2
	MODULATION CHARACTERISTICS		C.S0002 Section 3.1.3 C.S0002-A Section 3.1.3
	LIMITATIONS ON EMISSIONS		C.S0002 Section 3.1.4 C.S0002-A Section 3.1.4
	SYNCHRONIZATION, TIMING, AND PHASE		C.S0002 Section 3.1.5 C.S0002-A Section 3.1.5
	TRANSMITTER PERFORMANCE REQUIREMENTS		C.S0002 Section 3.1.6 C.S0002-A Section 3.1.6
RECEIVER	CHANNEL SPACING AND DESIGNATION		C.S0002 Section 3.2.1 C.S0002-A Section 3.2.1
	DEMODULATION CHARACTERISTICS		C.S0002 Section 3.2.2 C.S0002-A Section 3.2.2
	LIMITS ON EMISSIONS		C.S0002 Section 3.2.3 C.S0002-A Section 3.2.3
	RECEIVER PERFORMANCE REQUIREMENTS		C.S0002 Section 3.2.4 C.S0002-A Section 3.2.4

2

1 • **VOCODER CAPABILITIES**

2 The following vocoder capabilities are supported by the 3GPP2 system.

FEATURE	CATEGORY	ACRONYM	REFERENCE
MINIMUM PERFORMANCE STANDARD FOR SPEECH OPTION 1			C.S0012
HIGH REATE (13 kbps) SPEECH SO			C.S0020
- HIGH RATE SPEECH SO TTY/TDD ADDENDUM			C.S0020-1
- MINIMUM PERFORMANCE STANDARD FOR HR (13 kpbs)			C.S0021
ENHANCED VARIABLE RATE VOCODER		EVRC	C.S0014
- EVRC ADDENDUM FOR REMOVAL OF BIT EXACT			C.S0014-1
- EVRC TTY/TDD ADDENDUM			C.S0014-2
- MINIMUM PERFORMANCE STANDARD FOR EVRC			C.S0018

3

1 • LOGICAL CHANNELS

2 The following logical channels are supported by the 3GPP2 Release A system.

CAPABILITY/FEATURE	CATEGORY	ACRONYM	REFERENCE
LOGICAL CHANNELS	FORWARD COMMON SIGNALING CHANNEL	f-csch	C.S0003 C.S0003-A
	FORWARD DEDICATED MAC CHANNEL	f-dmch	C.S0003 C.S0003-A
	FORWARD DEDICATED SIGNALING CHANNEL	f-dsch	C.S0003 C.S0003-A
	FORWARD DEDICATED TRAFFIC CHANNEL	f-dtch	C.S0003 C.S0003-A
	REVERSE COMMON SIGNALING CHANNEL	r-csch	C.S0003 C.S0003-A
	REVERSE DEDICATED MAC CHANNEL	r-dmch	C.S0003 C.S0003-A
	REVERSE DEDICATED SIGNALING CHANNEL	r-dsch	C.S0003 C.S0003-A
	REVERSE DEDICATED TRAFFIC CHANNEL	r-dtch	C.S0003 C.S0003-A

3

1 • **MAC LAYER CAPABILITIES**

2 The following are general MAC layer capabilities of the 3GPP2 system.

CAPABILITY/FEATURE	CATEGORY	ACRONYM	REFERENCE
OVERVIEW AND DEFINITION OF MAC COMPONENTS			C.S0003 Section 1.7.1 C.S0003-A Section 1.7.1
LAYERING MODEL			C.S0003 Section 1.7.2 C.S0003-A Section 1.7.2
SERVICE INTERFACES			C.S0003 Section 2.1 C.S0003-A Section 2.1
ENTITIES OF MAC LAYER			C.S0003 Section 2.2 C.S0003-A Section 2.2
- RESOURCE CONTROL			C.S0003 Section 2.2.1 C.S0003-A Section 2.2.1
- OBJECTS			C.S0003 Section 2.2.2
- CONTROL PLANE ENTITIES			C.S0003 Section 2.2.3
- DATA PLANE ENTITIES			C.S0003 Section 2.2.4
- MAC SUBLAYER FUNCTIONAL ENTITIES			C.S0003-A Section 2.2.2
- SUPERVISORY PROCEDURES			C.S0003 Section 2.2.5 C.S0003-A Section 2.2.3

3

1 • LAC LAYER CAPABILITIES

2 The following reference is the conceptual model for the LAC Sublayer.

CAPABILITY/FEATURE	CATEGORY	ACRONYM	REFERENCE
CONCEPTUAL MODEL FOR THE LAC SUBLAYER			C.S0004 Annex A C.S0004-A Section 1.2
TIMERS AND CONSTANTS			C.S0004 Annex B C.S004-A Annex A

3

4 The following are general LAC layer capabilities of the 3GPP2 system for mobile stations.

CAPABILITY/FEATURE	CATEGORY	ACRONYM	REFERENCE
COMMON CHANNEL OPERATION			C.S0004 Section 2.1 C.S0004-A Section 2.1
- TRANSMISSION ON R-CSCH			C.S0004 Section 2.1.1 C.S0004-A Section 2.1.1
- RECEPTION ON F-CSCH			C.S0004 Section 2.1.2 C.S0004-A Section 2.1.2
DEDICATED CHANNEL OPERATION			C.S0004 Section 2.2 C.S0004-A Section 2.2
- TRANSMISSION ON R-CSCH			C.S0004 Section 2.2.1 C.S0004-A Section 2.2.1
- RECEPTION ON F-CSCH			C.S0004 Section 2.2.2 C.S0004-A Section 2.2.2

5

1 The following are general LAC layer capabilities of the 3GPP2 system for base stations.

CAPABILITY/FEATURE	CATEGORY	ACRONYM	REFERENCE
COMMON CHANNEL OPERATION			C.S0004 Section 3.1 C.S0004-A Section 3.1
- RECEPTION ON R-CSCH			C.S0004 Section 3.1.1 C.S0004-A Section 3.1.1
- TRANSMISSION ON F-CSCH			C.S0004 Section 3.1.2 C.S0004-A Section 3.1.2
DEDICATED CHANNEL OPERATION			C.S0004 Section 3.2 C.S0004-A Section 3.2
- RECEPTION ON R-CSCH			C.S0004 Section 3.2.1 C.S0004-A Section 3.2.1
- TRANSMISSION ON F-CSCH			C.S0004 Section 3.2.2 C.S0004-A Section 3.2.2

2

1 • **LAYER 3 SIGNALING CAPABILITIES**

2 The following references illustrate the general overview of Layer 3 Signaling.

CAPABILITY/FEATURE	CATEGORY	ACRONYM	REFERENCE
SIGNALING ARCHITECTURE			C.S0005 Section 1.2 C.S0005-A Section 1.2
SIGNALING AND FUNCTIONALITY			C.S0005 Section 1.3 C.S0005-A Section 1.2

3

4 The following are general Layer 3 Signaling capabilities of the 3GPP2 system for mobile stations.

CAPABILITY/FEATURE	CATEGORY	ACRONYM	REFERENCE
SECURITY AND IDENTIFICATION			C.S0005 Section 2.3 C.S0005-A Section 2.3
MONITORED QUANTITIES AND STATISTICS			C.S0005 Section 2.4
ACCUMULATED STATISTICS			C.S0005-A Section 2.4
CALL PROCESSING			C.S0005 Section 2.6
LAYER 3 PROCESSING			C.S0005-A Section 2.6
PDU FORMATS FOR MOBILE STATIONS			C.S0005 Section 2.7 C.S0005-A Section 2.7

5

1 The following are general Layer 3 Signaling capabilities of the 3GPP2 system for base stations.

CAPABILITY/FEATURE	CATEGORY	ACRONYM	REFERENCE
SECURITY AND IDENTIFICATION			C.S0005 Section 3.3 C.S0005-A Section 3.3
SUPERVISION			C.S0005 Section 3.4 C.S0005-A Section 3.4
CALL PROCESSING			C.S0005 Section 3.6
LAYER 3 PROCESSING			C.S0005-A Section 3.6
PDU FORMATS FOR MESSAGES			C.S0005 Section 3.7 C.S0005-A Section 3.7

2

3 The following are the hooks and extensions to the 3GPP2 system for support of 3GPP cross mode operations.

CAPABILITY/FEATURE	CATEGORY	ACRONYM	REFERENCE
CDMA DS ON ANSI-41			C.S0007
CDMA MC ON GSM-MAP			C.S0008

## 1 3GPP2 RADIO ACCESS NETWORK INTERFACE

2 This section details the capabilities and features of the 3GPP2 access network interface (i.e., A Interface).

CAPABILITY/FEATURE	CATEGORY	ACRONYM	REFERENCE
MSC-BS INTERFACE MODEL			A.S0001 Section 1.7
CALL PROCESSING AND SUPPLEMENTARY SERVICES			A.S0001 Section 2
- CALL CONTROL			A.S0001 Section 2.1
- A1 INTERFACE CALL SETUP			A.S0001 Section 2.2
- CALL CLEARING PROCEDURE			A.S0001 Section 2.3
- TRAFFIC CHANNEL RADIO LINK SUPERVISION			A.S0001 Section 2.4
- SUPPORT OF SUPPLEMENTARY SERVICES			A.S0001 Section 2.5
- DATA CALLS			A.S0001 Section 2.6
- SUPPORT OF SHORT MESSAGE SERVICE			A.S0001 Section 2.7
- SUPPORT OF OVER-THE-AIRSERVICE-PROVISIONING (OTASP)			A.S0001 Section 2.8
- ERROR HANDLING			A.S0001 Section 2.9
RADIO RESOURCE MANAGEMENT			A.S0001 Section 3
- RADIO CHANNEL SUPERVISION			A.S0001 Section 3.1
- RADIO CHANNEL MANAGEMENT			A.S0001 Section 3.2
- HANDOFF VIA MSC			A.S0001 Section 3.3
- HANDOFF VIA DIRECT BS-TO-BS SIGNALING			A.S0001 Section 3.4
- HANDOFF CALL FLOWS			A.S0001 Section 3.5

S.R0003: 3GPP2 System Capability Guide - Release A v1.0.0

CAPABILITY/FEATURE	CATEGORY	ACRONYM	REFERENCE
MOBILITY MANAGEMENT, AUTHENTICATION, AND PRIVACY			A.S0001 Section 4
- MOBILITY MANAGEMENT			A.S0001 Section 4.1
- AUTHENTICATION AND PRIVACY			A.S0001 Section 4.2
LAYERS 1 & 2 AND TERRESTRIAL FACILITY MANAGEMENT			A.S0001 Section 5
- PHYSICAL LAYER SPECIFICATION (LAYER 1)			A.S0001 Section 5.1
- ANSI SS7 TRANSPORT SPECIFICATION (LAYER 2)			A.S0001 Section 5.2
- USE OF ATM (LAYER 2)			A.S0001 Section 5.3
- TRANSPORT PROTOCOLS			A.S0001 Section 5.4
- TERRESTRIAL CIRCUIT MANAGEMENT PROCEDURES			A.S0001 Section 5.5
MESSAGES, INFORMATION ELEMENTS, AND TIMER DEFINITIONS			A.S0001 Section 6
SUPPLEMENTARY SERVICES ANNEX			A.S0001 Annex
ABIS INTERFACE			A.R0003
- FUNCTIONAL ARCHITECTURE AND INTERFACES			A.R0003 Section 4
- CALL PROCESSING			A.R0003 Section 5
- AB INTERFACE MESSAGE FORMATS			A.R0003 Section 6
- INFORMATION ELEMENT DEFINITIONS			A.R0003 Section 7

1 3GPP2 INTERSYSTEM INTERFACE

2 This section details the capabilities and features of the 3GPP2 intersystem interface.

FEATURE	CATEGORY	ACRONYM	REFERENCE
CELLULAR RADIOTELECOMMUNICATIONS INTERSYSTEM OPERATIONS			N.S0005
- PCS MULTI-BAND BASED ON IS-41-C			N.S0006
- DCCH BASED ON IS-41-C			N.S0007
- IMSI			N.S0009
- ANSI-41-D MISCELLANEOUS ENHANCEMENTS			N.S0015
- TIA/EIA-41-D ENHANCEMENTS FOR INTERNATIONALIZATION			N.S0016
- INTERNATIONAL IMPLEMENTATION OF WIRELESS TELECOMMUNICATIONS SYSTEMS COMPLIANT WITH TIA/EIA-41			N.S0017
- INTERSYSTEM LINK PROTOCOL			N.S0019

1 3GPP2 SYSTEM FEATURES

2 This section details the features of the 3GPP2 system.

FEATURE	CATEGORY	ACRONYM	REFERENCE
CELLULAR FEATURES DESCRIPTIONS			S.R0006
ADVANCE FEATURES IN WIDEBAND SPREAD SPECTRUM SYSTEMS			N.S0010
ADVICE OF CHARGE	STAGE 1	AOC	S.R0011
ANSWER HOLD	STAGE 1 STAGE 2/3	AH	S.R0008 N.S0002
CALLING NAME PRESENTATION / CALLING NAME RESTRICTION		CNAP/CNAR	N.S0012
FREEPHONE			N.S0004
GLOBAL EMERGENCY CALL ORIGINATION	STAGE 1	GECO	S.R0013
PREFERRED LANGUAGE ENHANCEMENT	STAGE 1 STAGE 2/3		S.R0010 N.S0004
PREMIUM RATE CHARGING			N.S0004
PREPAID CHARGING			N.S0018
REJECTION OF UNDESIRE ANNOYING CALLS	STAGE 1 STAGE 2/3	RUAC	S.R0012 N.S0004
USER SELECTIVE CALL FORWARDING	STAGE 1 STAGE 2/3	USCF	S.R0007 N.S0001
REMOVABLE USER IDENTITY MODULE	STAGE 1 STAGE 2/3	R-UIM	S.R0009 N.S0003

1 3GPP2 DATA SERVICES

2 This section details the data services, circuit and packet, support by the 3GPP2 system.

3 • CIRCUIT DATA

CAPABILITY/FEATURE	CATEGORY	ACRONYM	REFERENCE
CDMA DATA SERVICES			C.S0017 Section 3
- SERVICE OPTIONS FOR DATA SERVICES			C.S0017 Section 3.1
- ASYNC AND FAX SERVICES			C.S0017 Section 3.2
- PACKET DATA BEARER SERVICE			C.S0017 Section 3.3
- STU-III SERVICE			C.S0017 Section 3.4
- ANALOG FAX SERVICE			C.S0017 Section 3.5
- HIGH SPEED PACKET BEARER SERVICE			C.S0017 Section 3.6
INTERSYSTEM SUPPORT			C.S0017 Section 4
- PROTOCOL ARCHITECTURE			C.S0017 Section 4.1
- INTERSYSTEM INTERFACE			C.S0017 Section 4.2
DATA SERVICE OPTIONS FOR SPREAD SPECTRUM SYSTEMS: RADIO LINK PROTOCOL (RLP)			C.S0017 -1-10
DATA SERVICE OPTIONS FOR SPREAD SPECTRUM SYSTEMS: cdma2000 HIGH SPEED DATA SERVICES			C.S0017 -1-11

1 • **PACKET DATA**

CAPABILITY/FEATURE	CATEGORY	ACRONYM	REFERENCE
PROTOCOL REFERENCE MODEL			P.S0001 Section 4
SIMPLE IP OPERATION			P.S0001 Section 5
MOBILE IP OPERATION			P.S0001 Section 6
MOBILITY MANAGEMENT			P.S0001 Section 7
QUALITY OF SERVICE (QOS)			P.S0001 Section 8
ACCOUNTING			P.S0001 Section 9
R-P INTERFACE			P.S0001 Section 10
RADIO NETWORK REQUIREMENTS			P.S0001 Section 11
AIR INTERFACE			P.S0001 Section 12

1 3GPP2 SYSTEM SERVICES

2 This section details the system services supported by the 3GPP2 system.

FEATURE	CATEGORY	ACRONYM	REFERENCE
3G WIRELESS NETWORK MANAGEMENT	STAGE 1		S.R0017
AUTHETICATION			N.S0014
AUTOMATIC CODE GAPPING	STAGE 1		S.R0016
ISDN INTERWORKING	STAGE 1		S.R0015 C.S0017-0-2
LOCATION SERVICES			C.S0022
MOBILE STATION LOOPBACK TEST			C.S0013
OVER-THE-AIR SERVICE PROVISIONING		OTASP	C.S0016
OVER-THE-AIR PARAMETER ADMINISTRATION		OTAPA	N.S0011
SHORT MESSAGE SERVICE		SMS	C.S0015
TANDEM FREE OPERATION	STAGE 1	TFO	S.R0014 A.S0004
SERVICE OPTIONS:			
- SPEECH SERVICE OPTION			C.S0009
- DATA SERVICE OPTIONS FOR SPREAD SPECTRUM SYSTEMS			C.S0017
SERVICES IMPLEMENTED USING EXISTING PROTOCOLS			
- INTERNATIONAL ACCESS/+ CODE DIALING			S.R0004 Section 1
- CREDIT CARD CALLING SERVICE			S.R0004 Section 2
- CLOSED USER GROUP		CUG	S.R0004 Section 3
- ENHANCED ROUTING			S.R0004 Section 4

S.R0003: 3GPP2 System Capability Guide - Release A v1.0.0

FEATURE	CATEGORY	ACRONYM	REFERENCE
- INTERNATIONAL ROAMING			S.R0004 Section 5
- SPECIAL SERVICE DIALING		SPD	S.R0004 Section 6

1 ANALOG OPERATIONS

2 This section details the capabilities and features of the 3GPP2 analog operations.

CAPABILITY/FEATURE	CATEGORY	ACRONYM	REFERENCE
REQUIREMENTS FOR MOBILE STATION ANALOG OPERATION			C.S0006 Section 2 C.S0006 -A Section 2
- TRANSMITTER			C.S0006 Section 2.1 C.S0006 -A Section 2.1
- RECEIVER			C.S0006 Section 2.2 C.S0006 -A Section 2.2
- SECURITY AND IDENTIFICATION			C.S0006 Section 2.3 C.S0006 -A Section 2.3
- SUPERVISION			C.S0006 Section 2.4 C.S0006 -A Section 2.4
- MALFUNCTION DETECTION			C.S0006 Section 2.5 C.S0006 -A Section 2.5
- CALL PROCESSING			C.S0006 Section 2.6 C.S0006 -A Section 2.6
- SIGNALING FORMATS			C.S0006 Section 2.7 C.S0006 -A Section 2.7

S.R0003: 3GPP2 System Capability Guide - Release A v1.0.0

CAPABILITY/FEATURE	CATEGORY	ACRONYM	REFERENCE
REQUIREMENTS FOR BASE STATION ANALOG OPERATION			C.S0006 Section 3 C.S0006 -A Section 3
- TRANSMITTER			C.S0006 Section 3.1 C.S0006 -A Section 3.1
- RECEIVER			C.S0006 Section 3.2 C.S0006 -A Section 3.2
- SECURITY AND IDENTIFICATION			C.S0006 Section 3.3 C.S0006 -A Section 3.3
- SUPERVISION			C.S0006 Section 3.4 C.S0006 -A Section 3.4
- MALFUNCTION DETECTION			C.S0006 Section 3.5 C.S0006 -A Section 3.5
- CALL PROCESSING			C.S0006 Section 3.6 C.S0006 -A Section 3.6
- SIGNALING FORMATS			C.S0006 Section 3.7 C.S0006 -A Section 3.7
REQUIREMENTS FOR MOBIULE STATION OPTIONS			C.S0006 Section 4 C.S0006 -A Section 4
REQUIREMENTS FOR BASE STATION OPTIONS			C.S0006 Section 5 C.S0006 -A Section 5

## 1 APPENDIX

## 2 • 3GPP2 DOCUMENT REFERENCE LISTING

3GPP2 DOCUMENT #	TITLE	TIA REF #
<b>TSG-A RADIO ACCESS INTERFACE</b>		
A.S0001	3G-IOS	Rev.0 is 3G-IOS V4. Future point releases such as 3G-IOS V4.1 and V4.2 will correspond to rev.A, rev.B and so on. 3G-IOS V5 will be the next available revision number.
A.S0003	Abis interface specification	
A.S0004	Tandem Free Operation	
<b>TSG-C cdma2000 AIR INTERFACE</b>		
C.S0001-0	cdma2000 - Introduction	IS-2000-1
C.S0002-0	cdma2000 - Physical Layer	IS-2000-2
C.S0003-0	cdma2000 - MAC	IS-2000-3
C.S0004-0	cdma2000 - Layer 2 LAC	IS-2000-4
C.S0005-0	cdma2000 - Layer 3	IS-2000-5
C.S0006-0	cdma2000 - Analog	IS-2000-6
C.S0007-0	G3G CDMA-DS on ANSI-41	
C.S0008-0	G3G CDMA-MC on GSM-MAP	
C.S0009-0	Speech Service Option	TIA/EIA-96-C
C.S0010-0	Base Station Minimum Performance	TIA/EIA-97-D
C.S0011-0	Mobile Station Minimum Performance	TIA/EIA-98-D
C.S0012-0	Minimum Performance Standard for Speech SO 1	TIA/EIA-125-A
C.S0013-0	Mobile Station Loopback Test	TIA/EIA-126-C
C.S0014-0	Enhanced Variable Rate Codec (EVRC)	IS-127
C.S0014-0-1	EVRC addendum for removal of bit exact	IS-127-1
C.S0014-0-2	EVRC TTY/TDD addendum	IS-127-2
C.S0015-0	Short Message Service	TIA/EIA-637-A
C.S0016-0	OTASP of MS in Spread Spectrum Systems	IS-683-A

S.R0003: 3GPP2 System Capability Guide - Release A v1.0.0

3GPP2 DOCUMENT #	TITLE	TIA REF #
C.S0017-0	(14.4 kbps) Data SOs for Spread Spectrum Systems - STU III Transparent + Non-Trans - Async Data + G3 Fax - Packet (Internet + CDPD) - Analog Fax (Rate Set 1+2)	IS-707-A
C.S0017-0-1	Addendum for cdma2000 RLP and additional packet data support	IS-707-A-1
C.P0017-0-2	Data SOs for Spread Spectrum Systems	IS-707-A-2
C.S0018-0	Minimum Performance Specification for EVRC	IS-718
C.S0020-0	High Rate (13 kbps) Speech SO	IS-733
C.S0020-0-1	High Rate Speech SO TTY/TDD addendum	IS-733-1
C.S0021-0	Minimum Performance for HR (13 kbps)	IS-736-A
C.S0022-0	Location Services (Position Determination Service)	IS-801
C.S0023	Removable User Identity Module	IS-820
C.R1000-0	Requirements Mapping for cdma2000	TSB2000
C.R1001-0	Parameter Value Assignments	TSB58-B
C.P9001	SMV (Selectable Mode Vocoder)	PN-4575
<b>TSG-N INTERSYSTEM INTERFACE</b>		
N.S0001	User Selective Call Forwarding	PN-4551
N.S0002	Answer Hold	PN-4550
N.S0003	User Identity Module	PN-4582
N.S0004	WIN Phase 2 - Triggers for Preferred Language - Advice of Charge - Rejection of Undesired Annoying Calls - Premium Rate Charging - Freephone	PN-4289
N.S0005	Cellular Radiotelecommunications Intersystem Operations	ANSI-41-D
N.S0006	PCS Multi-band-Based on IS-41-C	TSB-76
N.S0007	DCCH Based on IS-41-C	IS-730
N.S0008	Circuit Modes Services-Data-Based on IS-41-C	IS-737
N.S0009	IMSI	IS-751
N.S0010	Advanced Features in Wideband Spread Spectrum Systems	IS-735
N.S0011	OTASP and OTAPA	IS-725-A
N.S0012	CNAP/CNAR	IS-764
N.S0013	WIN	IS-771

S.R0003: 3GPP2 System Capability Guide - Release A v1.0.0

3GPP2 DOCUMENT #	TITLE	TIA REF #
N.S0014	Authentication Enhancements	IS-778
N.S0015	ANSI-41-D Miscellaneous Enhancements	
N.S0016	TIA/EIA-41-D Enhancements for Internationalization	IS-807
N.S0017	International Implementation of Wireless Telecommunication Systems Compliant with TIA/EIA-41	TSB-29-C
N.S0018	TIA/EIA-41-D Prepaid Charging	PN-4287
N.S0019	Intersystem Link Protocol	IS-728
<b>TSG-P PACKET DATA SERVICES</b>		
P.S0001	Wireless IP Network Architecture based on IETF Protocols	
P.S0002	Wireless IP Network Standard	PN-4286
<b>TSG-S SERVICES AND SYSTEMS ASPECTS</b>		
S.R0001	3GPP2 Specifications List	
S.R0002	3G Capability Descriptions	
S.R0003	System Capability Guide	
S.R0004	System Implementation Guide	
S.R0005	3GPP2 Network Reference Model	
S.R0006	Cellular Features Description	IS-664-A
S.R0007	User Selective Call Forwarding (Stage1)	PN-4551
S.R0008	Answer Hold (Stage1)	PN-4550
S.R0009	User Identity Module (Stage1)	PN-4582
S.R0010	Preferred Language Enhancement (Stage1)	
S.R0011	Advice of Charge (Stage1)	PN-4289
S.R0012	Rejection of Undesired Annoying Calls (Stage1)	PN-4289
S.R0013	Global Emergency Call Origination (Stage1)	
S.R0014	Tandem Free Operation (Stage1)	
S.R0015	ISDN Interworking (Stage1)	
S.R0016	Automatic Code Gapping (Stage1)	PN-4410
S.R0017	3G Wireless Network Management System High Level Requirements (Stage 1)	[IS-4108]
S.R0018	Prepaid Charging (Stage 1)	PN-4287
S.R0019	Location Services System Support (Stage 1)	IS-801

1 • AIR INTERFACE PARAMETER ADMINISTRATION

CAPABILITY/FEATURE	REFERENCE
3GPP2 PARAMETER ADMINISTRATION PROCESS	C.R1001 Section 2
SERVICE OPTION NUMBER ASSIGNMENTS	C.R1001 Section 3
DATA BURST MESSAGE TYPE ASSIGNMENTS	C.R1001 Section 4
MULTIPLEX OPTION NUMBER ASSIGNMENTS	C.R1001 Section 5
MANUFACTURER-SPECIFIC OTASP ASSIGNMENTS	C.R1001 Section 7
ROAMING DISPLAY INDICATOR ASSIGNMENTS	C.R1001 Section 8
SHORT MESSAGE SERVICES ASSIGNMENTS	C.R1001 Section 9

2  
3