

1  
2  
3  
4  
5

3GPP2 P.S0001-A  
Version 3.0  
Version Date: July 16, 2001



3RD GENERATION  
PARTNERSHIP  
PROJECT 2  
"3GPP2"

6  
7

---

## **Wireless IP Network Standard**

8

9

10

11  
12  
13  
14  
15

### **COPYRIGHT**

*3GPP2 and its Organizational Partners claim copyright in this document and individual Organizational Partners may copyright and issue documents or standards publications in individual Organizational Partner's name based on this document. Requests for reproduction of this document should be directed to the 3GPP2 Secretariat at [shoyler@tia.eia.org](mailto:shoyler@tia.eia.org). Requests to reproduce individual Organizational Partner's documents should be directed to that Organizational Partner. See [www.3gpp2.org](http://www.3gpp2.org) for more information.*

16

**CONTENTS**

1  
2  
3  
4

5 **1 INTRODUCTION..... 5**

6 **2 GLOSSARY AND DEFINITIONS ..... 7**

7 2.1 ACRONYMS ..... 7

8 2.2 DEFINITIONS..... 8

9 **3 REFERENCES.....10**

10 3.1 MOBILE IP.....10

11 3.2 PPP.....10

12 3.3 DIFFERENTIATED SERVICES .....10

13 3.4 RADIUS .....11

14 3.5 IP SECURITY.....11

15 3.6 IETF OTHER.....11

16 3.7 3GPP2 AND TIA .....11

17 3.8 ITU-T.....12

18 **4 PROTOCOL REFERENCE MODEL .....13**

19 4.1 SIMPLE IP .....13

20 4.2 MOBILE IP.....13

21 4.3 RADIUS .....14

22 4.4 NETWORK REFERENCE MODELS .....15

23 **5 SIMPLE IP OPERATION .....18**

24 5.1 COMMON SERVICE SPECIFICATION.....18

25 5.1.1 *PPP Session* .....18

26 5.2 PDSN REQUIREMENTS .....18

27 5.2.1 *PPP Session* .....18

28 5.2.1.1 Establishment .....18

29 5.2.1.2 Termination .....18

30 5.2.1.3 Authentication.....19

31 5.2.1.4 Addressing with IPCP .....19

32 5.2.1.5 Compression .....19

33 5.2.1.6 PPP Octet synchronous Framing .....19

34 5.2.1.7 Simultaneous Simple IP and Mobile IP Service .....19

35 5.2.2 *RADIUS Support* .....19

36 5.2.2.1 NAI Construction in the Absence of CHAP.....20

37 5.2.3 *Ingress Address Filtering* .....21

38 5.3 RADIUS SERVER REQUIREMENTS .....21

39 5.4 MOBILE STATION REQUIREMENTS.....21

40 5.4.1 *PPP Session* .....22

41 5.4.1.1 Establishment.....22

42 5.4.1.2 Termination .....22

43 5.4.1.3 Authentication.....22

44 5.4.1.4 Addressing with IPCP .....22

45 5.4.1.5 Compression .....22

46 5.4.1.6 PPP Framing.....23

47 **6 MOBILE IP OPERATION.....24**

48 6.1 COMMON SERVICE SPECIFICATION.....24

49 6.1.1 *PPP Session* .....24

50 6.1.2 *Mobile IP* .....24

1	6.2	PDSN REQUIREMENTS .....	24
2	6.2.1	<i>PPP Session</i> .....	24
3	6.2.1.1	Establishment .....	24
4	6.2.1.2	Termination .....	24
5	6.2.1.3	Authentication .....	25
6	6.2.1.4	Addressing with IPCP .....	25
7	6.2.1.5	Compression .....	25
8	6.2.1.6	PPP Octet Synchronous Framing.....	25
9	6.2.2	<i>MIP Registration</i> .....	25
10	6.2.2.1	Agent Advertisements .....	25
11	6.2.2.2	Addressing and Mobile IP .....	26
12	6.2.2.3	MIP Extensions .....	26
13	6.2.2.4	Private Network Support .....	26
14	6.2.2.5	Reverse Tunneling .....	26
15	6.2.3	<i>RADIUS Support</i> .....	27
16	6.2.4	<i>IP Security Support</i> .....	27
17	6.2.5	<i>Ingress Address Filtering</i> .....	29
18	6.3	HOME AGENT REQUIREMENTS.....	29
19	6.3.1	<i>Multiple Registrations</i> .....	30
20	6.3.2	<i>IP Security Support</i> .....	30
21	6.3.3	<i>Dynamic Home Address Assignment</i> .....	30
22	6.3.4	<i>Authentication</i> .....	30
23	6.4	RADIUS SERVER REQUIREMENTS .....	31
24	6.5	MOBILE STATION REQUIREMENTS.....	31
25	6.5.1	<i>PPP Session</i> .....	31
26	6.5.1.1	Establishment .....	31
27	6.5.1.2	Termination .....	31
28	6.5.1.3	Authentication with CHAP .....	31
29	6.5.1.4	Addressing with IPCP .....	32
30	6.5.1.5	Compression .....	32
31	6.5.1.6	PPP Framing .....	32
32	6.5.2	<i>MIP Registration</i> .....	32
33	6.5.2.1	Agent Discovery.....	32
34	6.5.2.2	Registration Messages.....	32
35	6.5.2.3	MIP Extensions .....	33
36	6.5.2.4	Private Network Support .....	33
37	<b>7</b>	<b>MOBILITY MANAGEMENT .....</b>	<b>34</b>
38	7.1	MOBILITY WITHIN RADIO NETWORK.....	34
39	7.2	PCF TO PCF HANDOFF .....	34
40	7.3	PDSN TO PDSN HANDOFF.....	34
41	<b>8</b>	<b>QUALITY OF SERVICE (QOS).....</b>	<b>36</b>
42	8.1	DIFFERENTIATED SERVICES SPECIFICATION .....	36
43	8.2	PDSN REQUIREMENTS FOR DIFFERENTIATED SERVICES.....	36
44	8.2.1	<i>Service Specification</i> .....	36
45	8.2.2	<i>3GPP2 Differentiated Service Class Option</i> .....	37
46	8.3	RN REQUIREMENTS FOR DIFFERENTIATED SERVICE .....	37
47	8.4	MOBILE STATION REQUIREMENTS FOR DIFFERENTIATED SERVICE .....	37
48	<b>9</b>	<b>ACCOUNTING .....</b>	<b>38</b>
49	9.1	GENERAL.....	38
50	9.2	AIRLINK RECORDS .....	38
51	9.2.1	<i>R-P Session Setup Airlink Record</i> .....	39
52	9.2.2	<i>Active Start Airlink Record</i> .....	40
53	9.2.3	<i>Active Stop Airlink Record</i> .....	40
54	9.2.4	<i>SDB Airlink Record</i> .....	40

1	9.3	PDSN USAGE DATA RECORD (UDR) .....	41
2	9.4	ACCOUNTING FORMATS.....	42
3	9.5	PDSN PROCEDURES.....	46
4	9.5.1	<i>R-P Session Setup Airlink Record Arrives</i> .....	46
5	9.5.2	<i>Packet Data Service Establishment</i> .....	47
6	9.5.3	<i>Packet Data Service Termination</i> .....	47
7	9.5.4	<i>User Data Through PDSN</i> .....	47
8	9.5.5	<i>Active Start Airlink Record Arrives</i> .....	47
9	9.5.6	<i>Active Stop Airlink Record Arrives</i> .....	48
10	9.5.7	<i>SDB Airlink Record Arrives</i> .....	48
11	9.5.8	<i>Interim Record Trigger</i> .....	48
12	9.5.9	<i>Stop Record Trigger</i> .....	48
13	9.5.10	<i>Time of Day Timer Expires</i> .....	48
14	<b>10</b>	<b>R-P INTERFACE .....</b>	<b>50</b>
15	<b>11</b>	<b>RADIO NETWORK REQUIREMENTS.....</b>	<b>51</b>
16	11.1	R-P GENERAL HANDOFF REQUIREMENTS.....	51
17	<b>12</b>	<b>AIR INTERFACE .....</b>	<b>52</b>
18		<b>ANNEX A: IKE/ISAKMP PAYLOADS .....</b>	<b>53</b>
19		<b>ANNEX B: CERTIFICATES .....</b>	<b>56</b>
20		<b>ANNEX C: RADIUS ATTRIBUTES .....</b>	<b>58</b>
21		<b>ANNEX D: INTERIM RADIUS ACCOUNTING .....</b>	<b>62</b>

22  
23  
24  
25  
26  
27  
28  
29  
30  
31  
32  
33  
34  
35  
36  
37  
38  
39  
40  
41  
42  
43

**Figures**

Figure 1: Protocol Reference Model for Simple IP .....	13
Figure 2: Protocol Reference Model for Mobile IP Control and IKE.....	14
Figure 3: Protocol Reference Model for Mobile IP User Data.....	14
Figure 4: RADIUS Protocol Reference Model.....	15
Figure 5: Reference Model for Access with Mobile IP .....	16
Figure 6: Reference Model for Access with Simple IP.....	17
Figure 8: Accounting Architecture.....	38
Figure 9: 3GPP2 RADIUS Attribute Format.....	58

**Tables**

Table 1: R-P Session Setup Airlink Fields.....	39
Table 2: Active Start Airlink Fields.....	40
Table 3: Active Stop Airlink Fields.....	40
Table 4: SDB Airlink Fields.....	41
Table 5: Complete UDR .....	42
Table 6: Accounting Parameter Attribute RADIUS Definitions.....	45

1 **Reason for Addendum**

2 This addendum of P.S0001 has been created for the following reasons:

3

4 - New mechanism for PDSN/HA pre-shared key distribution for IKE

5 - Security status is replaced by *IKE Pre-shared Secret Request* attribute

6 - New counters G15 and G16 for Mobile IP signaling

7 - Clarifications with respect to counters G1 and G2

8 - A new indicator in RADIUS stop message to indicate session still in progress (to avoid  
9 release of the IP address)

10 - Removal of RADIUS accounting fields H1, I2, and I3

11 - New accounting session to be created when F1, F2 accounting fields vary

12 - Non-zero and zero IP address in IP Configuration option in IPCP is treated as simple IP by  
13 PDSN. Mobile IP is supported with null IP address configuration option (i.e., not included).

14

1

2 **1 Introduction**

3 This specification defines requirements for support of wireless packet data networking capability  
4 on a third generation wireless system based on cdma2000. This specification is based on  
5 P.R0001; cdma2000 Wireless IP Network Architecture based on IETF protocols.

6 This specification defines the two methods for accessing Public networks (Internet) and Private  
7 networks (Intranets): Simple IP and Mobile IP, and the required Quality of Service and  
8 Accounting support. IETF protocols are widely employed whenever possible to minimize the  
9 number of new protocols required and to maximize the utilization of well accepted standards and  
10 hence the speed to market. References to the required IETF protocols are provided in Section 3  
11 of this specification.

12 Following this introduction, the Glossary and Definitions are given in Section 2, and References  
13 are provided in Section 3. Section 4 describes the protocol reference models for Simple IP,  
14 Mobile IP, RADIUS, and the overall wireless packet data network. Sections 5 and 6 describe  
15 Simple IP operation and Mobile IP operation, respectively. The common service specification  
16 and the requirements placed on the network elements (PDSN, HA, and RADIUS Server) and the  
17 mobile station to support each operation are described in the corresponding section. Section 7  
18 describes Mobility Management for PCF-PCF and PDSN-PDSN handoff. Specifications required  
19 for Quality of Service and Accounting are described in Sections 8 and 9, respectively. Sections  
20 10, 11, and 12 describe the R-P Interface, Radio Network Requirements, and Air Interface,  
21 respectively.

22

## 1    **2    Glossary and Definitions**

### 2    **2.1    *Acronyms***

3		
4	AAA	Authentication, Authorization, and Accounting
5	ACCM	Asynchronous Control Character Map
6	AH	Authentication Header
7	CA	Certificate Authority
8	CCP	Compression Control Protocol
9	CHAP	Challenge Handshake Authentication Protocol
10	COA	Care-of-Address
11	CRL	Certificate Revocation List
12	DSA	Digital Signature Algorithm
13	DOI	Domain of Interpretation
14	ESP	Encapsulating Security Payload
15	FA	Foreign Agent
16	FAC	Foreign Agent Challenge
17	GRE	Generic Routing Encapsulation
18	HA	Home Agent
19	HLR	Home Location Register
20	IANA	Internet Assigned Numbering Authority
21	IETF	Internet Engineering Task Force
22	IKE	Internet Key Exchange
23	IMSI	International Mobile Station Identity
24	IMT-2000	International Mobile Telecommunications - 2000
25	IP	Internet Protocol
26	IPCP	IP Control Protocol
27	IPsec	IP Security
28	IRM	International roaming MIN
29	ISAKMP	Internet Security Association and Key Management Protocol
30	ISP	Internet Service Provider
31	LAC	Link Access Control
32	LCP	Link Control Protocol
33	MAC	Medium Access Control
34	MIN	Mobile Identification Number
35	MIP	Mobile IP
36	MS	Mobile Station
37	MSID	Mobile Station ID
38	NAI	Network Access Identifier
39	PAP	Password Authentication Protocol
40	PCF	Packet Control Function
41	PDSN	Packet Data Serving Node
42	PHB	Per Hop Behavior
43	PL	Physical Layer
44	PPP	Point-to-Point Protocol
45	PSI	PCF Session ID
46	QoS	Quality of Service
47	RADIUS	Remote Authentication Dial In User Service
48	RN	Radio Network
49	RRP	Mobile IP Registration Reply
50	RRQ	Mobile IP Registration Request
51	RSA	Rivest-Shamir-Adleman public key algorithm
52	SA	Security Association

1	SDB	Short Data Burst
2	SHA	Secure Hash Algorithm
3	SPI	Security Parameter Index
4	SS7	Signaling System 7
5	TCP	Transmission Control Protocol
6	UDR	Usage Data Record
7	UDP	User Datagram Protocol
8	VLR	Visitor Location Register

9     **2.2     Definitions**

10  
11  
12  
  
13  
14  
15  
16  
17  
18  
  
19  
20  
  
21  
22  
  
23  
24  
25  
  
26  
27  
28  
29  
  
30  
31  
32  
33  
34  
35  
36  
  
37  
38  
39  
  
40  
41  
42  
43  
44  
45  
46

Access Provider Network:

An IMT-2000 cellular network providing access to the mobile user.

Broker RADIUS:

An intermediate RADIUS server that has security relationships with the *Visited RADIUS* and the *Home RADIUS* and is used to securely transfer RADIUS messages between the *Visited Access Provider Network* and the *Home IP Network*. In some situations, there may be more than one broker RADIUS in the path between visited RADIUS and home RADIUS.

Broker RADIUS Network:

A network with an administrative domain that contains the *Broker RADIUS*.

Home RADIUS:

The RADIUS server that resides in the *Home IP Network*.

Home Access Provider Network:

The IMT-2000 cellular network that is the home for the mobile subscriber unit. The user may have a different home network for data services.

Home IP Network:

The home network that provides IP based data services to the user. This network is where the user's NAI is homed. This network may be a private corporate network, publicly accessible ISP network, or an IMT-2000 network.

IMT-2000 network:

An IMT-2000 home/visited network is characterized by its ability to provide IMT-2000 capabilities to its users as identified in the IMT-2000 capability sets (ITU-Q.1701).

Packet data service:

A general term describing a packet switched data service offered by an IMT-2000 network to a mobile subscriber (user).

Packet data service option:

A service option provides a means between MS and RN to establish and maintain cdma2000 Traffic Channels for packet data service.

Packet data session:

Describes an instance of continuous use of packet data service by the user. A packet data session begins when the user invokes packet data service. A packet data session ends when the user or the network terminates packet data service. During a particular packet data session, the user may change locations but the same IP address is maintained.

1 For Simple IP service, moving from the coverage area of one PDSN to another PDSN  
2 constitutes a change in packet data session because a new IP address is assigned by  
3 the new PDSN. For Simple IP service, a packet data session and a PPP session are  
4 concurrent. For Mobile IP service, a packet data session can span several PDSNs as  
5 long as the user continuously maintains mobility bindings at the Home Agent and there is  
6 no lapse in Mobile IP registrations/re-registrations (i.e., the IP address is persistent). For  
7 Mobile IP service, the Packet Data session can exist through several changes of the  
8 PPP session.

9 PPP Session:

10 A PPP session describes the time during which a particular PPP connection instance is  
11 maintained in the open state in both the mobile station and PDSN. The PPP session is  
12 maintained during periods when the mobile station is dormant. If a user hands off from  
13 one RN to another RN but is still connected to the same PDSN, the PPP session  
14 remains. If a user changes PDSN, a new PPP session is created at the new PDSN.

15 Private Network:

16 A *Home IP Network* that resides behind a firewall and that may use private IP addresses.

17 Radio Network:

18 The RN is equivalent to the BS as defined in the Network Reference Model  
19 (TIA/EIA/TSB100), and corresponds to the collection of radio access equipment that  
20 includes the functional entities Radio Resource Control (RRC) and Packet Control  
21 Function (PCF) as described in P.R0001. At times the terms PCF and RN are used  
22 interchangeably in this document when describing handoffs across the R-P interface.  
23

24 R-P Interface:

25 The interface between the Radio Network (specifically the PCF) and the PDSN. This  
26 interface is also referred to as the  $A_{\text{quarter}}$  interface and the A10/A11 interface in A.S0001.

27 R-P session:

28 The R-P session is a logical connection established over the R-P interface for a  
29 particular PPP session. If a user changes RNs during packet data service, the R-P  
30 session is between the previous RN and PDSN is released and a new R-P session is  
31 established between the new RN and the same or new PDSN.

32 Service Provider Network:

33 An IMT-2000 network operated by either the home service provider or the visited service  
34 provider. The home service provider maintains the customer business relationship with  
35 the user. The visited service provider provides IMT-2000 access services through the  
36 establishment of a service agreement with a home service provider.

37 Visited Access Provider Network:

38 The IMT-2000 cellular network providing service to the user when he is roaming outside  
39 his home access provider network.

40 Visited RADIUS:

41 The RADIUS server that resides in the Visited Access Provider Network.

42

1   **3   References**

2   **3.1    *Mobile IP***

- 3   Perkins, IPv4 Mobility, RFC 2002, May 1995.  
4  
5   Perkins, IP Encapsulation within IP, RFC 2003, October 1996.  
6  
7   Perkins, Minimal Encapsulation within IP, RFC 2004, October 1996.  
8  
9   Solomon, Applicability Statement for IP Mobility support, RFC 2005, October 1995.  
10  
11   Cong, Hamnlen, Perkins, The Definitions of Managed Objects for IP Mobility Support Using  
12   SMLv2, RFC 2006, October 1995.  
13  
14   Montenegro, Reverse Tunneling for Mobile IP, RFC 2344, May 1998.  
15  
16   Calhoun, Perkins, Mobile IPv4 Challenge/Response Extensions, RFC 3012, November 2000.  
17  
18   Calhoun, Perkins, Mobile NAI Extension RFC 2794. March 2000.

19   **3.2    *PPP***

- 20   Simpson, The Point to Point Protocol (PPP), RFC 1661, July 1994.  
21  
22   Simpson, Mobile-IPv4 Configuration Option for PPP IPCP, RFC 2290, February 1998.  
23  
24   Simpson, PPP in HDLC-like Framing, RFC 1662, July 1994.  
25  
26   Rand, The PPP Compression Control Protocol (CCP), RFC 1962, June 1996.  
27  
28   Friend, Simpson, PPP Stac LZS Compression Protocol, RFC 1974, August 1996.  
29  
30   Woods, PPP Deflate Protocol, RFC 1979, August 1996.  
31  
32   Simpson, PPP Challenge Handshake Authentication Protocol (CHAP), RFC 1994, August 1996.  
33  
34   McGregor, The PPP Internet Protocol Control Protocol (IPCP), RFC 1332, May 1992.  
35  
36   Pall , Microsoft Point-To-Point Compression (MPPC) Protocol, RFC 2118, March 1997.  
37  
38   Zorn, PPP LCP Internationalization Configuration Option, RFC 2484, January 1999.

39   **3.3    *Differentiated Services***

- 40   Nichols, Blake, Baker, Black, Definition of the Differentiated Services Field (DS Field) in the  
41   IPv4 and IPv6 Headers, RFC 2474, December 1998.  
42  
43   Blake, Black, Carlson, Davies, Wang, Weiss, An Architecture for Differentiated Services, RFC  
44   2475, December 1998.  
45  
46   Heinanen, Baker, Weiss, Wroclawski, Assured Forwarding PHB Group, RFC 2597, June 1999.  
47  
48   Jacobson, Nichols, Poduri, An Expedited Forwarding PHB, RFC 2598, June 1999.

1 **3.4 RADIUS**

2 Rigney, RADIUS Accounting, RFC 2139, April 1997.

3  
4 Rigney, Rubens, Simpson, Willens, Remote Authentication Dial In User Service (RADIUS), RFC  
5 2138, August 1997.

6  
7 Rivest, R., and S. Dusse, "The MD5 Message-Digest Algorithm", RFC 1321, MIT Laboratory for  
8 Computer Science, RSA Data Security Inc., April 1992.

9  
10 Zorn et al., RADIUS Attributes for Tunnel Support, RFC 2868, June 2000.

11 **3.5 IP Security**

12 Kent, Atkinson, Security Architecture for the Internet Protocol, RFC 2401, November 1998.

13  
14 Kent, Atkinson, IP Encapsulating Security Payload (ESP), RFC 2406, November 1998.

15  
16 Kent, Atkinson, IP Authentication Header, RFC 2402, November 1998.

17 **3.6 IETF Other**

18 Postel, User Datagram Protocol, RFC 768, August 1980.

19  
20 Internet Protocol, RFC 791, Sept. 1981.

21  
22 Postel, Internet Control Message Protocol, RFC 792, September 1981.

23  
24 Transmission Control Protocol, RFC 793, September 1981.

25  
26 Braden, Requirements for Internet Hosts - Communication Layers, RFC 1122, October 1989.

27  
28 Address Allocation for Private Internets, RFC 1918, February, 1996.

29  
30 Jacobson, Compressing TCP/IP Headers for Low Speed Serial Links, RFC 1144, February 1990.

31  
32 Harkins, Carrel, The Internet Key Exchange (IKE), RFC 2409, November 1998.

33 **3.7 3GPP2 and TIA**

34 P.R0001, Wireless IP Network Architecture based on IETF Protocols, July 2000.

35  
36 A.S0001-A, 3GPP2 Access Network Interfaces, Interoperability Specification, December, 2000.

37  
38 TIA/EIA/IS-707-A-2.12: cdma2000 High Speed Packet Data Service Option 33, March 2001.

39  
40 C.S0001-A: Introduction to cdma2000 Standards for Spread Spectrum Systems, June 2000.

41  
42 C.S0002-A: Physical Layer Standard for cdma2000 Spread Spectrum Systems, June 2000.

43  
44 C.S0003-A: Medium Access Control (MAC) Standard for cdma2000 Spread Spectrum Systems,  
45 June 2000.

46  
47 C.S0004-A: Signaling Link Access Control (LAC) Standard for cdma2000 Spread Spectrum  
48 Systems, June 2000.

49  
50 C.S0005-A: Upper Layer (Layer 3) Signaling Standard for cdma2000 Spread Spectrum Systems,  
51 June 2000.

1

2 TIA/EIA-553: Mobile Identification Number (MIN).

3

4 TIA/EIA/TSB29-A, International Implementation of Cellular Radiotelephone Systems Compliant  
5 with ANSI/EIA/TIA 553, September 1992.

6 **3.8** *ITU-T*

7 ITU-T Recommendation E.212, The International Identification Plan for Mobile Terminals and  
8 Mobile Users.

9

10 ITU-T recommendation X.509, Public-key and attribute certificate frameworks.

11

12

1 **4 Protocol Reference Model**

2 This section will specify the protocol architecture between the entities of the Wireless IP Network  
 3 architecture. Refer to P.R0001 for a general description of the Wireless IP Network architecture,  
 4 its components and message flows.

5  
 6 The mobile station either may be a single MT0 type device or may consist of a MT2 and a TE2  
 7 device. For a MT0 type mobile station, the protocols involving the mobile station terminate  
 8 within the single MT0 device as shown in the Figures below. In the case of a MT2 TE2 type  
 9 mobile station, the protocol termination within the mobile station are as shown in Figures 1 and 2  
 10 of IS-707-A-2.12.

11  
 12 Although Mobile IP and Simple IP services are represented in different protocol reference  
 13 models, the network is able to provide both Simple IP and Mobile IP service simultaneously to a  
 14 mobile station using the same PPP session.

15 **4.1 Simple IP**

16 Figure 1 shows the protocol reference model for Simple IP service.  
 17  
 18

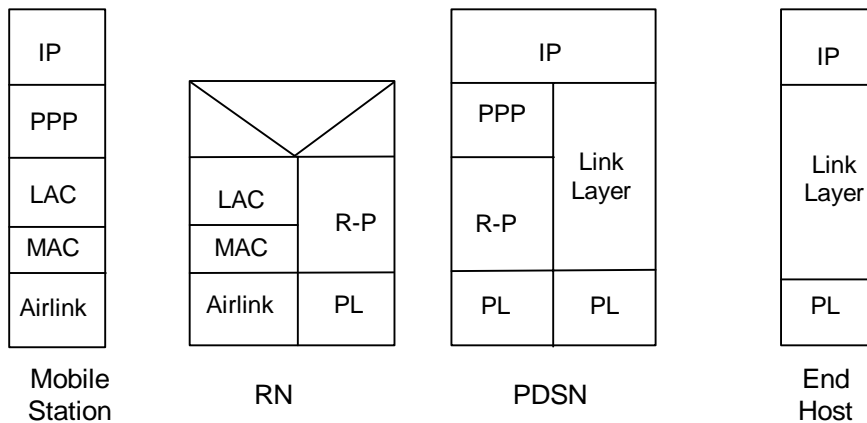

19  
 20  
 21  
 22

**Figure 1: Protocol Reference Model for Simple IP**

23 **4.2 Mobile IP**

24 Figures 2 and 3 show the protocol reference model for Mobile IP control and data, respectively.  
 25 IPsec in Figures 2 and 3 will be necessary in some situations and not in other situations, as  
 26 detailed in Section 6.2.4.  
 27

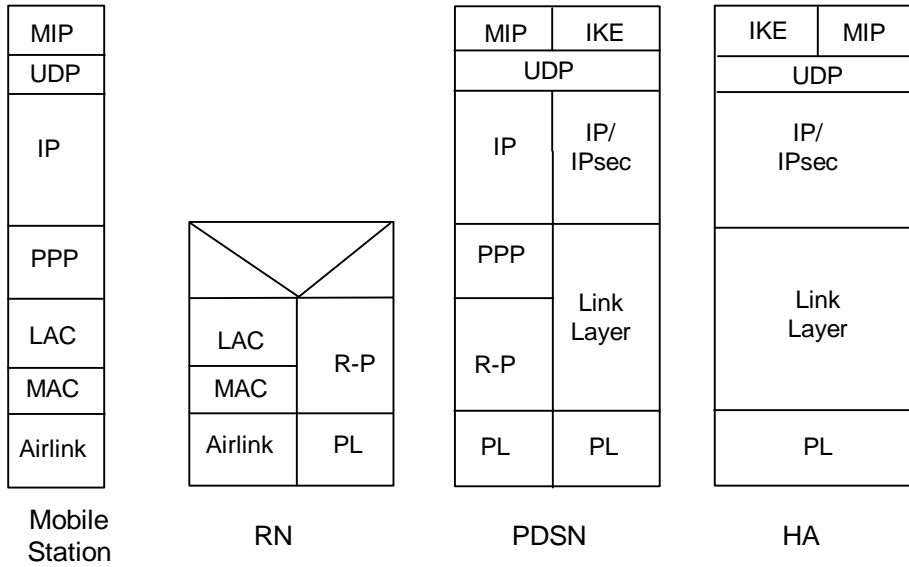

Figure 2: Protocol Reference Model for Mobile IP Control and IKE

1  
2  
3  
4  
5

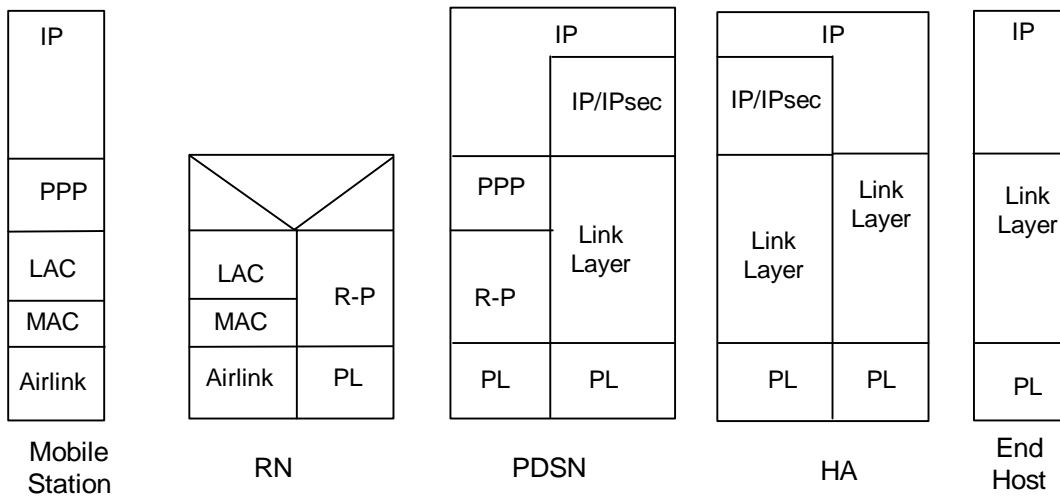

Figure 3: Protocol Reference Model for Mobile IP User Data

6  
7  
8

9 **4.3 RADIUS**

10 Figure 4 shows the protocol reference model for RADIUS server to wireless data entity. In the  
11 protocol reference model of Figure 4, the RADIUS servers in the visited access provider and  
12 home IP network communicate via RADIUS proxy servers and one or more RADIUS brokers.

13 Note: The broker is optional.  
14  
15

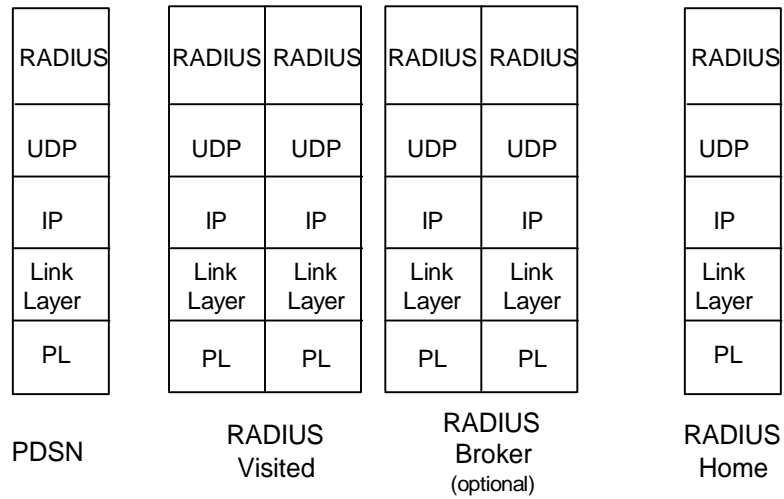

1  
2  
3  
4

**Figure 4: RADIUS Protocol Reference Model**

5 **4.4 Network Reference Models**

6 Figure 5 shows an IMT-2000 network control plane reference model with IMT-2000 service  
7 provider boundaries. For the case of Mobile IP Service to the local and public network access in  
8 which the mobile station is roaming, the HA will reside in a home access provider network. For  
9 private network or home ISP access, the HA will reside in the respective external network.

10  
11 For the Simple IP Service, the HA will not be required, as shown in Figure 6.

12  
13 Note: The IP Network entity in Figures 5 and 6 represent IP Networks that may reside in the  
14 public Internet as well as private IP networks within access provider networks and home IP  
15 networks.

16

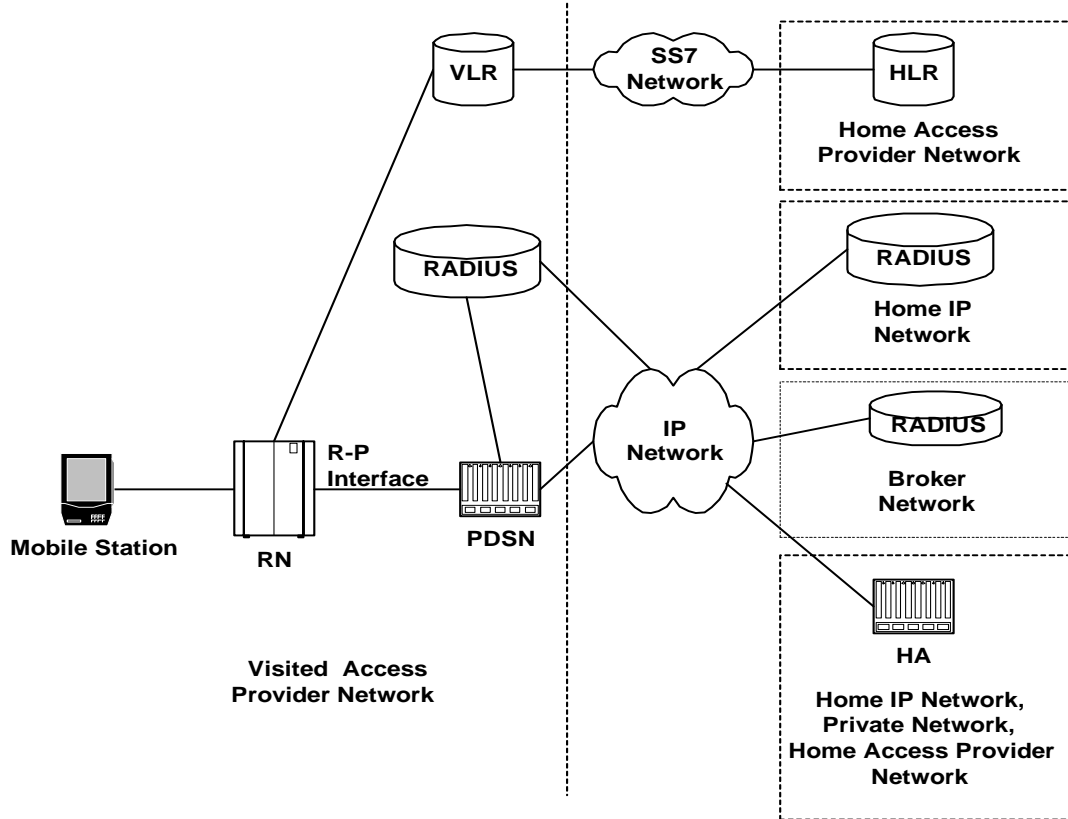

1  
2  
3  
4

Figure 5: Reference Model for Access with Mobile IP

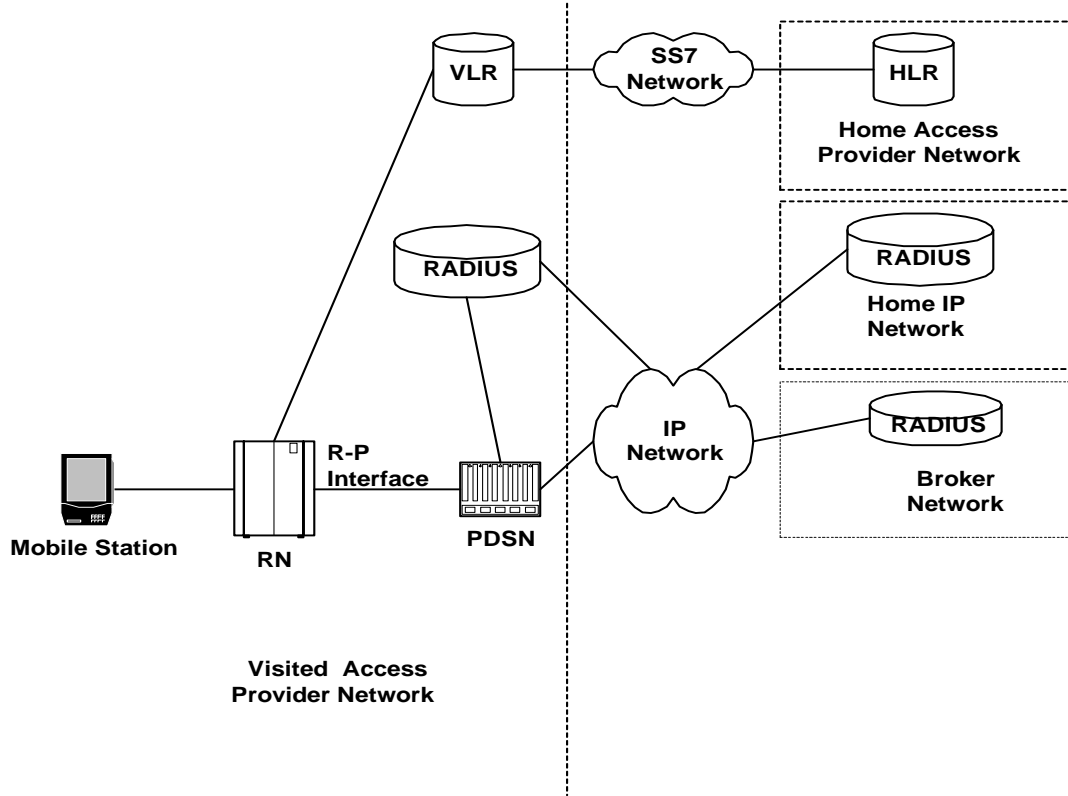

- 1
- 2
- 3
- 4
- 5

Figure 6: Reference Model for Access with Simple IP

## 1    **5       Simple IP Operation**

2    This section describes the requirements and procedures for Simple IP operation. In this  
3    specification, Simple IP refers to a service in which the user is assigned a dynamic IP address  
4    from the local PDSN and is provided IP routing service by a service provider network. The user  
5    retains its IP address as long as it is served by a radio network which has connectivity to the  
6    address assigning PDSN. There is no IP address mobility beyond this PDSN. Secure access to  
7    a home network via Simple IP is beyond the scope of this specification.

### 8    **5.1       Common Service Specification**

9    The common requirements for several network elements (e.g., PDSN and mobile station) for  
10   Simple IP operation are described here.

#### 11   **5.1.1     PPP Session**

12   PPP shall be the data link protocol between the mobile station and the PDSN. PPP is  
13   established prior to any IP datagrams being exchanged between the mobile station and the  
14   PDSN.

15  
16   PPP shall be supported as defined in the following standards with any limitations or extensions  
17   described in this specification:

- 18       ▪ Point to Point Protocol [RFC 1661];
- 19       ▪ PPP byte oriented HDLC [RFC 1662];
- 20       ▪ IPCP [RFC 1332]

21  
22   PPP encryption shall not be negotiated by either the mobile station or PDSN. Only one PPP  
23   session shall be supported between the mobile station and the PDSN.

### 24   **5.2       PDSN Requirements**

25   The PDSN shall support Simple IP operation.

#### 26   **5.2.1     PPP Session**

##### 27   **5.2.1.1   Establishment**

28   Immediately after the RN opens an R-P session for a mobile station, the PDSN shall send an  
29   LCP Configure-Request for a new PPP session to the mobile station. If the RN establishes an R-  
30   P session corresponding to a mobile station for which a PPP session already exists, the PDSN  
31   shall not send an LCP Configure-Request to the mobile station.

32  
33   PPP shall support transparency in accordance with section 4.2 of RFC 1662. The PDSN shall  
34   attempt to negotiate a control character mapping with the minimum number of escaped  
35   characters by proposing an ACCM of 0x00000000.

##### 36   **5.2.1.2   Termination**

37   The PDSN shall clear the PPP state if there is no established underlying R-P session for the  
38   mobile station. The PDSN shall clear the R-P session whenever the PPP session is closed. If  
39   the PDSN receives IP packets for a mobile station for which there is no established PPP session  
40   for the mobile station, the PDSN shall discard the packet and send an ICMP destination  
41   unreachable packet to the source.

42  
43   The PDSN shall support a PPP inactivity timer for each PPP session. When the inactivity timer  
44   expires, the PDSN shall terminate the PPP session and shall take usual steps such as release of  
45   the R-P session to the RN that supports the expired PPP session.

1  
2 The PDSN shall clear the R-P session whenever the PPP Session is closed by the mobile station.

### 3 **5.2.1.3 Authentication**

4 The PDSN shall support the authentication mechanisms CHAP and PAP. The PDSN shall also  
5 support a configuration option to allow a MS to receive Simple IP service without CHAP or PAP.  
6 The PDSN shall always propose CHAP as a PPP option in an initial LCP Configure-Request  
7 during the PPP establishment.

8  
9 If the MS does not support or does not want to use CHAP, but prefers to use PAP, it will send an  
10 LCP Configure Nak proposing PAP. The PDSN will accept PAP by sending an LCP Configure-  
11 Request with PAP.

12  
13 If the MS does not support either CHAP or PAP, it will send an LCP Configure Reject. If the  
14 PDSN is configured to allow the MS to receive Simple IP service without CHAP or PAP, the  
15 PDSN will adhere to the guidelines in 5.2.2.1.

### 16 **5.2.1.4 Addressing with IPCP**

17 The PDSN shall assign the mobile station a dynamic IP address for Simple IP service during the  
18 IPCP phase of PPP. The IP address may be a private address as per RFC 1918.

19  
20 If the MS did not authenticate itself using CHAP or PAP, and the PDSN is not configured to allow  
21 the MS to receive Simple IP service without CHAP or PAP, the PDSN shall end the PPP session  
22 if the MS sends an IPCP Configure-Request containing the IP Address Configuration Option with  
23 value 0.0.0.0.

### 24 **5.2.1.5 Compression**

25 The PDSN shall support CCP [RFC 1962] for the negotiation of PPP compression. The PDSN  
26 shall support Van Jacobson TCP/IP header compression [RFC 1144].

27  
28 The PDSN shall support the following types of PPP compression:

- 29
- 30 ▪ Stac-LZS [RFC 1974];
- 31 ▪ Microsoft Point-To-Point Compression Protocol [RFC 2118] compression;
- 32 ▪ Deflate [RFC 2394]

33  
34 The PDSN may support other PPP payload compression algorithms.

### 35 **5.2.1.6 PPP Octet synchronous Framing**

36 The PDSN shall frame PPP packets sent on the PPP link layer using the octet synchronous  
37 framing protocol defined in RFC 1662, except that there shall be no inter-frame time fill (see  
38 4.4.1 of RFC 1662). That is, no flag octets shall be sent between a flag octet that ends one PPP  
39 frame and the flag octet that begins the subsequent PPP frame.

### 40 **5.2.1.7 Simultaneous Simple IP and Mobile IP Service**

41 This specification allows simultaneous Mobile IP and Simple IP service to the mobile station. If  
42 the user desires Simple IP service after previously requesting Mobile IP service, the mobile  
43 station must re-negotiate PPP.

### 44 **5.2.2 RADIUS Support**

45 The PDSN shall act as a RADIUS client in accordance with RFC 2138 and shall communicate  
46 user CHAP or PAP authentication information to the local RADIUS server in a RADIUS Access-

1 Request. On receipt of the CHAP or PAP response from the mobile station, the PDSN shall  
2 create an Access-Request containing at a minimum:

- 3
- 4 User-Name (1)<sup>1</sup> = NAI
- 5 User-password (2) = password (if PAP)
- 6 CHAP-Password (3) = CHAP ID and CHAP-response (if CHAP)
- 7 NAS-IP-Address (4) = IP address of PDSN<sup>2</sup>
- 8 CHAP-Challenge (60) = challenge value issued by PDSN (if CHAP)<sup>3</sup>
- 9 Correlation ID (as defined in Table 6, Accounting parameter attribute RADIUS definition) =  
10 An ID that correlates all accounting sessions authorized for this NAI by this access  
11 request
- 12

13 Correlation ID is in addition to those fields specified by RFC 2138.

14  
15 The local RADIUS server will send a RADIUS Access-Accept message to the PDSN. The  
16 RADIUS Access Accept message may contain the Differentiated Service Class Option attribute.  
17 This attribute is defined in Annex C.

18  
19 The PDSN shall act as a RADIUS accounting client in accordance with RFC 2139 and shall  
20 communicate user accounting information to the local RADIUS server in RADIUS Accounting-  
21 Requests. The Accounting-Request shall contain the Accounting Session ID attribute (44)  
22 generated by the PDSN.

23  
24 The security of communications between PDSN and RADIUS server may optionally be protected  
25 with IP security. The establishment of the security association is outside the scope of this  
26 specification.

#### 27 **5.2.2.1 NAI Construction in the Absence of CHAP**

28 In the event that the mobile station does not negotiate CHAP or PAP, no mobile station NAI is  
29 received by the PDSN. In this case, the PDSN shall not perform additional authentication of the  
30 user. If the PDSN is capable of constructing a properly formatted NAI [RFC 2486] based on the  
31 MSID then accounting records will be generated and these records are keyed on the user NAI.  
32 The NAI shall be constructed in the form <MSID>@<realm>, where <MSID> is the MSID of the  
33 mobile station, and <realm> is the Internet realm of the home network that owns the mobile  
34 station MSID. If the PDSN is unable to construct an NAI for an MS, then the PDSN may deny  
35 service to the MS.

36  
37 The mobile station shall use one of the following MSID formats:

- 38
- 39 ▪ International Mobile Station Identity (IMSI) [E.212]
- 40 ▪ Mobile Identification Number (MIN) [TIA/EIA-553]
- 41 ▪ International Roaming MIN (IRM) [TIA/EIA/TSB29]
- 42
- 43

44 The PDSN shall write the constructed NAI into accounting records and the realm value may  
45 optionally be used by the visited RADIUS server to forward these records to the correct home

---

<sup>1</sup> The numbers in this list correspond to the RADIUS attribute types defined in RFC 2138 and RFC 2139.

<sup>2</sup> This is the IP address the PDSN uses as a source address in the RADIUS Accept-Request.

<sup>3</sup> Per RFC 2138, if the CHAP Challenge value is 16 octets long, the CHAP Challenge may be placed in a Request Authenticator.

1 RADIUS server for proper summary and settlement<sup>4</sup>. The constructed NAI shall not be used for  
 2 authentication. The PDSN shall send RADIUS accounting messages to the local RADIUS server  
 3 using the constructed NAI in the absence of CHAP if configured by the operator.  
 4  
 5  
 6

7 **5.2.3 Ingress Address Filtering**

8 The PDSN shall check the source IP address of every packet received on the PPP link from the  
 9 mobile station. If the address is not associated with the PPP Session to the mobile station, and  
 10 is not a MIP RRQ or Agent Solicitation, then the PDSN shall discard the packet, and send an  
 11 LCP Configure-Request to restart the PPP session<sup>5</sup>.

12 **5.3 RADIUS Server Requirements**

13 RADIUS Server shall follow the guidelines specified in RFC 2138 and RFC 2139.  
 14

15 The local RADIUS server shall also support, and the broker RADIUS server should support, the  
 16 Interim Accounting Record in Annex D and accounting attributes listed in Section 9.4.  
 17

18 The local RADIUS server shall also support, and the broker and home RADIUS servers should  
 19 support, the Differentiated Services Class attribute in Annex C.  
 20

21 If the mobile station uses CHAP or PAP, the RADIUS server will receive a RADIUS Access-  
 22 Request from the PDSN with CHAP or PAP authentication information, and shall forward the  
 23 RADIUS Access-Request to the home network or a peer (e.g., a broker) if it does not have the  
 24 authority to accept/deny the request. This is in accordance with RFC 2138. In that case, the  
 25 RADIUS server will later receive a RADIUS Access-Accept message from the home or broker  
 26 network. The RADIUS server shall then send the RADIUS Access-Accept to the PDSN.  
 27

28 The RADIUS server will receive a RADIUS Accounting Start from the PDSN. The RADIUS  
 29 server later receives a RADIUS Accounting Stop from the PDSN in accordance with RFC 2139.  
 30 The RADIUS server may also receive Interim Accounting records between the Accounting Start  
 31 and Stop messages as necessary in accordance with Annex C. If the RADIUS server is in the  
 32 visited network, the visited RADIUS server shall forward the RADIUS accounting messages to  
 33 the home or broker network.  
 34

35 The security of communications between RADIUS servers may optionally be protected with IP  
 36 security. The establishment of the security association is outside the scope of this specification.  
 37 Also see RFC 2138 for additional RADIUS security requirements.

38 **5.4 Mobile Station Requirements**

39 The mobile station may optionally support Simple IP. When the mobile station wants to use  
 40 Simple IP, the mobile station shall use packet data service option 33 as specified in TIA/EIA/IS-  
 41 707-A-2.12.

---

<sup>4</sup> The home RADIUS server may require an MSID to user conversion table to map the constructed NAI to the user's actual NAI to complete the billing process in cases where the constructed NAI differs from the actual NAI.

<sup>5</sup> The reason to restart PPP is because the user could have started a Simple IP session during a previous dormant handoff to another PDSN and returned; in this case the current PDSN would not know the mobile station had invoked Simple IP and received another IP address. Thus, restarting PPP will force the Simple IP session to get a topologically correct address.

1 **5.4.1 PPP Session**

2 The mobile station shall use PPP as the data link protocol for Simple IP.

3 **5.4.1.1 Establishment**

4 The mobile station shall exchange LCP messages as described in RFC 1661.

5

6 PPP shall support control escaping in accordance with 4.2 of RFC 1662. The PPP Link Layer  
7 shall support negotiation of Asynchronous Control Character Mapping as defined in RFC 1662.  
8 The mobile station should negotiate a control character mapping. If the mobile station  
9 negotiates control character mapping, it should attempt the minimum number of escapes by  
10 negotiating an ACCM of 00000000.

11 **5.4.1.2 Termination**

12 When the mobile station wishes to terminate packet data service, the mobile station should send  
13 LCP-terminate to the PDSN to gracefully close the PPP session before terminating the packet  
14 data service with the RN.

15

16 If the mobile station becomes aware that the RN has terminated packet data service, the mobile  
17 station may consider its PPP session closed at that point.

18 **5.4.1.3 Authentication**

19 The mobile station shall support CHAP authentication for Simple IP. However, the network  
20 operator may configure a mobile station to not use CHAP. In that case, the mobile station shall  
21 be permitted to skip over the CHAP phase by sending a Configure-Reject to the PDSN in  
22 response to a Configure-Request that offers the CHAP option.

23

24 The mobile station may support PAP authentication for Simple IP. If the mobile station uses PAP,  
25 it shall respond to an LCP Configure-Request for CHAP with an LCP Configure-Nak proposing  
26 PAP.

27

28 For both CHAP and PAP, the MS shall send an NAI of the form user@realm.

29 **5.4.1.4 Addressing with IPCP**

30 The mobile station shall send an IP address of 0.0.0.0 during the IPCP phase to request a  
31 dynamic IP address from the network. The mobile station shall accept the address provided by  
32 the PDSN.

33 **5.4.1.5 Compression**

34 The mobile station shall support Van Jacobson TCP/IP header compression [RFC 1144]. The  
35 TCP/IP header compression shall be configured through IPCP. The mobile station may support  
36 PPP Compression Control Protocol [RFC 1962]. If the mobile station wishes PPP payload  
37 compression, the mobile station should use PPP Compression Control Protocol to negotiate a  
38 PPP payload compression algorithm, and the mobile station shall support one of the following  
39 compression algorithms:

- 40 ▪ Stac-LZS [RFC 1974];
- 41 ▪ Microsoft Point-To-Point Compression Protocol [RFC 2118];
- 42 ▪ Deflate [RFC 2394]

43

44 The mobile station may support additional PPP payload compression algorithms.

1 **5.4.1.6 PPP Framing**

2 The mobile station shall use the octet-synchronous framing protocol defined in RFC 1662. One  
3 exception is there shall be no inter-frame time fill, i.e., no flag octets shall be sent between a flag  
4 octet that ends one PPP frame and the flag octet that begins the subsequent PPP frame.<sup>6</sup>

5

---

<sup>6</sup> If the mobile station consists of a laptop and a relay-model handset, the laptop may send inter-frame time fill that prevents the mobile from becoming dormant.

## 1    **6    Mobile IP Operation**

2    This section describes the requirements and procedures for Mobile IP operation. In this  
3    specification, Mobile IP refers to a service based on a set of RFCs (including RFC 2002), in  
4    which the user is provided IP routing service to a public IP network and/or secure IP routing  
5    service to predefined private IP networks. The MS is able to use either a non-zero static IP  
6    address or a dynamically assigned IP address belonging to its home IP network HA. The MS  
7    shall have a non-zero static Home Agent address assigned regardless of whether the mobile  
8    station has a static or dynamic Home Address. The user is able to maintain a persistent IP  
9    address even when handing off between radio networks connected to separate PDSNs.

### 10   **6.1    Common Service Specification**

11    The common requirements for several network elements (e.g., PDSN and mobile station) for  
12    Mobile IP operation are described here.

#### 13    **6.1.1    PPP Session**

14    See Section 5.1.1.

15  
16    For Mobile IP, neither CHAP nor PAP should be performed. If CHAP or PAP is performed,  
17    longer initial setup time and re-establishment time will occur as the result of an additional  
18    RADIUS traversal.

19  
20    Note that the MN-AAA Challenge Extension procedures [RFC 3012] shall be performed  
21    regardless of whether or not CHAP is performed.

#### 22    **6.1.2    Mobile IP**

23    Mobile IP operation shall be supported as defined in the following standards with any limitations  
24    or extensions described in this specification:

- 25
- 26    ▪    RFC 2002-2006;
- 27    ▪    Reverse Tunneling [RFC 2344];
- 28    ▪    Foreign Agent Challenge/Response [RFC 3012];
- 29    ▪    NAI Extension [RFC 2794]

### 30    **6.2    PDSN Requirements**

31    The PDSN shall support Mobile IP operation.

#### 32    **6.2.1    PPP Session**

33    The PDSN shall support multiple Mobile IP home addresses over the single PPP session.

##### 34    **6.2.1.1    Establishment**

35    See Section 5.2.1.1.

##### 36    **6.2.1.2    Termination**

37    The PDSN shall clear the PPP state if there is no established underlying R-P session for the  
38    mobile station. The PDSN shall clear the R-P session whenever the PPP session is closed. If  
39    the PDSN receives IP packets for a mobile station for which there is no established PPP session  
40    for the mobile station, the PDSN shall discard the packet and send an ICMP destination  
41    unreachable packet to the source. If the PDSN receives a failure code in the RRP where the  
42    RRQ may not be retransmitted, and there are no other active IP addresses on the PPP link, then  
43    the PDSN should clear the PPP session after delivering the RRP to the mobile station. If the

1 PDSN generates a failure code other than 69, and there are no other active IP addresses on the  
2 PPP link, the PDSN should deliver the RRP and clear the PPP sessions.

3  
4 For Mobile IP service, the PPP inactivity timer shall be set to a value larger than the FA's  
5 maximum allowable values for Mobile IP registration lifetime.

### 6 **6.2.1.3 Authentication**

7 The PDSN shall propose CHAP in an LCP Configure-Request. For Mobile IP the mobile station  
8 should not use CHAP or PAP and should respond with an LCP Configure-Reject requesting no  
9 CHAP or PAP authentication. The PDSN shall re-send an LCP Configure-Request without the  
10 authentication option after receiving the LCP Configure-Reject (CHAP or PAP) from mobile  
11 stations. Mobile stations will respond with an LCP Configure-Ack as described in RFC 1661.

### 12 **6.2.1.4 Addressing with IPCP**

13 For both Mobile IP static home address assignment and dynamic home address assignment,  
14 prior to the initial MIP registration:

- 15 ▪ The mobile station shall not include an IP-Address Configuration Option in the IPCP  
16 Configure-Request to the PDSN, and,<sup>8</sup>
- 17 ▪ The PDSN shall not assign an IP address to the mobile station.

18  
19 The PDSN shall not support RFC 2290. If the mobile station uses the Mobile IPv4 Configuration  
20 Option [RFC 2290], the PDSN shall reply with an IPCP Configure-Reject.

### 21 **6.2.1.5 Compression**

22 See Section 5.2.1.5.

### 23 **6.2.1.6 PPP Octet Synchronous Framing**

24 See Section 5.2.1.6.

## 25 **6.2.2 MIP Registration**

### 26 **6.2.2.1 Agent Advertisements**

27 For the mobile station that uses Mobile IP, the PDSN shall begin transmission of an operator  
28 configurable number of Agent Advertisements immediately following establishment of PPP, or  
29 upon reception of an Agent Solicitation message from the mobile station. If the mobile station  
30 sends a Mobile IP RRQ to the PDSN, the PDSN shall cease sending Agent Advertisements.  
31 Once the PDSN sends the configurable number of Advertisements, the PDSN shall not send  
32 further Advertisements, unless it receives an Agent Solicitation message from the mobile station.  
33 For Simple IP service, the PDSN shall not send any Agent Advertisements to the mobile station  
34 following establishment of PPP.

35  
36 The Mobile IP Registration Lifetime field in the Agent Advertisement shall be smaller than the  
37 PPP inactivity timer.

38  
39 Upon receiving a handoff indication including SID/NID/PZID of the previous PCF and  
40 SID/NID/PZID of the current PCF, if the PDSN already supports a Mobile IP service for the  
41 mobile station, the PDSN shall use this information to determine whether or not Mobile IP re-  
42 registration is required for the mobile station. If re-registration is required, then the PDSN shall  
43 re-negotiate PPP and send Agent Advertisements.

---

<sup>8</sup> If the mobile station includes an IP-Address Configuration Option in the IPCP Configure-Request to the PDSN, the PDSN will consider it as a mobile station using Simple IP service. In this case, the PDSN will send a Nack and then a Configure-Request that proposes a new IP address. The MS should then send a Configure-Request with the new IP address.

1  
2 In order to minimize Agent Advertisements sent over the air, the PDSN shall not send unsolicited  
3 Agent Advertisements to a mobile station periodically to refresh the FA advertisement lifetime.  
4 The mobile station may send Agent Solicitations when the FA advertisement lifetime expires.  
5 The Advertisement Lifetime is a configurable value and the recommended value should be set to  
6 9000 seconds (the maximum ICMP router advertisement lifetime).

#### 7 **6.2.2.2 Addressing and Mobile IP**

8 The PDSN shall support both static and dynamic home address assignments. For dynamic  
9 home address assignment, the PDSN shall accept Mobile IP RRQs with a 0.0.0.0 source address  
10 from the mobile station. For dynamic home address assignment, the PDSN will acquire the  
11 home address from the Mobile IP RRP. In order to provide public network access and to  
12 provide private network access across the Internet, the PDSN must use a publicly routable and  
13 visible care-of-address.

#### 14 **6.2.2.3 MIP Extensions**

15 The PDSN shall include MN-FA Challenge Extension [RFC 3012] in the Agent Advertisement.  
16 Since Advertisements are rarely sent (to save air resources) the PDSN shall include in the RRP  
17 the next challenge that the mobile should use in its next re-registration with this PDSN. On re-  
18 registration, the PDSN may communicate user FAC authentication information to the home  
19 RADIUS server, via broker servers if required, in a RADIUS Access-Request. The frequency of  
20 this re-authentication and re-authorization is configurable by the operator. The challenge shall  
21 be changed on a serving access provider configurable basis.

22 The PDSN shall not remove the MN-FA Challenge Extension and MN-AAA Authentication  
23 Extension from the RRQ.

24 If the PDSN receives an RRQ that does not contain an MN-HA Authentication Extension, it shall  
25 send an RRP to the mobile station with an error code of 70 to indicate the RRQ was poorly  
26 formed.

#### 27 **6.2.2.4 Private Network Support**

28 The PDSN shall support private home addresses. If the mobile station desires a private home  
29 address then the mobile station will negotiate reverse tunneling [RFC 2344]. If the mobile station  
30 desires a private home address but does not negotiate reverse tunneling, the PDSN shall send a  
31 failed RRP with error code 75. The PDSN shall form a logical association that contains the R-P  
32 Session ID, the mobile station's home address, and the Home Agent address. When the PDSN  
33 receives a packet for a registered mobile station from the Home Agent, the PDSN shall map the  
34 mobile station's Home Agent address and the home address to one association, and shall  
35 transmit the packet on the R-P connection indicated by the R-P Session ID of the association.  
36

37 If two Home Agents assign a single mobile station the same address, the PDSN shall send a  
38 failed RRP with an Administratively-Prohibited error code (65) to the mobile station. The first  
39 assigned address is not affected.

#### 40 **6.2.2.5 Reverse Tunneling**

41 The PDSN shall reject a Mobile IP registration with an error code of 75 if a private home address  
42 as defined in RFC 1918 is present in either the RRQ or RRP, and the RRQ did not indicate  
43 reverse tunneling.  
44

45 If the home RADIUS server sends a Reverse Tunnel Specification attribute in the RADIUS  
46 Access-Accept indicating that reverse tunneling is required, and the mobile station did not  
47 indicate reverse tunneling in the RRQ, the PDSN shall reject the registration with an error code  
48 of 75. If the mobile station negotiates reverse tunneling, then the PDSN shall reverse tunnel

1 both direct delivered and encapsulated packets. This applies to unicast, multicast, and  
 2 broadcast IP destination addresses, even if the direct delivery mode is used.

3  
 4 The PDSN must support both direct delivered and encapsulated packets.

5 **6.2.3 RADIUS Support**

6 The PDSN shall act as a RADIUS client in accordance with RFC 2138. On initial mobile access,  
 7 the PDSN shall communicate user FAC authentication information to the home RADIUS server,  
 8 via the broker RADIUS servers if required, in a RADIUS Access-Request. On receipt of the MIP  
 9 RRQ from the mobile station, the PDSN shall create an Access Request containing at a  
 10 minimum the following:

- 11 User-Name (1) = MN-NAI field in the MN-NAI Extension
- 12 CHAP-Password (3) =
- 13 CHAP Ident field = High-order byte of the Challenge Field in the MN-FA Challenge
- 14 Extension
- 15 String field = Authenticator field from the MN-AAA Extension
- 16 CHAP-Challenge (60) = MD5 (Preceding MIP RRQ, Type, Length, SPI), followed by the
- 17 least-order 237 bytes of the Challenge Field in the MN-FA Challenge Extension.
- 18 The MD5 checksum is computed over the MIP RRQ data preceding the MN-AAA
- 19 Extension and the Type, Length, SPI fields of the MN-AAA Extension.
- 20 NAS-IP-Address (4) = IP address of the PDSN COA contained in RRQ
- 21 Home Agent Address (as defined in Annex C) = HA address contained in the RRQ
- 22 Correlation ID (as defined in Table 6, Accounting parameter attribute RADIUS definition)
- 23 = An ID that correlates all accounting sessions authorized for this NAI by this access
- 24 request
- 25 IKE Pre-shared Secret Request (as defined in Annex C) = security state that may
- 26 currently exist between the PDSN and HA
- 27
- 28

29 If the authentication succeeds, the local RADIUS server will send a RADIUS Access-Accept  
 30 message to the PDSN. The RADIUS Access-Accept message may contain the 3GPP2 RADIUS  
 31 attributes list in Annex C. If the authentication fails, the local RADIUS server will send a RADIUS  
 32 Access-Reject to the PDSN.

33  
 34 The PDSN shall act as a RADIUS accounting client in accordance with RFC 2139 and shall  
 35 communicate user accounting information to the local RADIUS server in RADIUS Accounting-  
 36 Requests. The PDSN shall determine at completion of the IPCP phase that an Accounting-  
 37 Request Start message shall be sent to the server following a successful Mobile IP registration  
 38 Reply received from the HA. The Accounting-Request Start shall contain the Accounting  
 39 Session ID and Correlation ID attribute generated by the PDSN.

40  
 41 The security of communications between PDSN and RADIUS server may optionally be protected  
 42 with IP security. The establishment of security is outside the scope of this specification.

43 **6.2.4 IP Security Support**

44 There may be a statically configured shared secret for computing the Mobile IP HA/FA  
 45 authentication extension in Mobile IP registration messages. If such a shared secret exists, the  
 46 PDSN and HA shall use it.

47  
 48 Additional security associations between the PDSN and HA may also be supported for the  
 49 protection of Mobile IP control messages and user data. This specification supports the following  
 50 options:

- 51 ▪ IKE and public certificates
- 52 ▪ Dynamic pre-shared IKE secret distributed by the home RADIUS server
- 53 ▪ Statically configured IKE pre-shared secret

1  
2 The PDSN shall support IPsec and IKE, including a shared secret for IKE that may be statically  
3 or dynamically provisioned. The implementation of IPsec implies support for IPsec AH as a  
4 minimum requirement. The PDSN shall support the capability to accept a shared key from the  
5 home RADIUS server, and the PDSN may support X.509 based certificates. The Home RADIUS  
6 server optionally supports the *3GPP2 RADIUS* attributes and the PDSN shall support the *3GPP2*  
7 *RADIUS* attributes.

8  
9 The security association shall be determined as follows:

10  
11 Upon receiving a MIP RRQ from a mobile station, the PDSN sends an Access-Request message  
12 as outlined in Section 6.2.3. That Access-Request shall contain the *IKE Pre-shared Secret*  
13 *Request* attribute that has one of the possible values:

- 14
- 15     ▪ The PDSN requests a pre-shared secret for IKE.
- 16     ▪ The PDSN does not request a pre-shared secret for IKE.
- 17

18 The appropriate *3GPP2 Security Level* attribute included in the Access-Accept message allows  
19 the home RADIUS server to indicate whether IP security should be applied on registration  
20 messages and/or tunneled data from PDSN to HA, or not to use IPsec at all. The mobile stations  
21 served by a given PDSN belonging to the same HA will receive the same security service  
22 between PDSN and HA. In the event the service should be provided to the user, the home  
23 RADIUS server authorizes the PDSN to either use an existing security association with the  
24 corresponding HA or to establish a new security association if no prior SA exists.

25  
26 If IPsec services are authorized, and the *IKE Pre-shared Secret Request* attribute in the Access-  
27 Request from the PDSN indicate that a pre-shared IKE secret is desired, the home RADIUS If  
28 IPsec services are authorized, and the *IKE Pre-shared Secret Request* attribute in the Access-  
29 server may distribute a key identifier and pre-shared secret for IKE to the PDSN using the *Pre-*  
30 *Shared-Secret* and *KeyID* attributes in the Access-Accept. The Home RADIUS server generates  
31 a pre-shared key by processing the Home RADIUS IP address, FA IP address, and a timestamp  
32 as well as a secret key, known as the 'S' key, through the *HMAC-MD5* hashing algorithm. The 'S',  
33 key is known between the Home RADIUS server and HA. The 'S' key is retrieved on the HA via  
34 the Home RADIUS server and has a configurable lifetime. The lifetime of the 'S' key is a home  
35 RADIUS local policy, and is based on the cryptographic strength of 'S'. The pre-share key is  
36 generated using the following formula;

$$37$$

$$38 \quad K = \text{HMAC-MD5} (\text{Home RADIUS IP address, FA IP address, timestamp, 'S'})$$

39  
40 If certificates or static pre-shared keys are not available then the PDSN shall request a pre-  
41 shared secret from the home RADIUS server. If the PDSN has included an IKE Pre-shared  
42 Secret Request with a value of 1, and the Home RADIUS server does not return a pre-shared  
43 key, and if the PDSN is mandated via *Security Level* attribute to use IPsec, then the PDSN shall  
44 reject the RRQ with administratively prohibited code of 65.

45  
46 If the Home RADIUS server has indicated that an IP security association shall be used between  
47 the PDSN and HA, the PDSN shall provide IPsec services as indicated in the *3GPP2 security*  
48 *level* attribute. If no security association currently exists, the PDSN shall attempt to establish the  
49 security association using the HA X.509 certificates. If no HA X.509 certificate exists, but the  
50 root certificate exists, the PDSN shall attempt to establish the security association using X.509  
51 certificates as received in Phase 1 IKE. If the necessary certificates do not exist, the PDSN shall  
52 attempt to use the dynamically distributed shared secret for IKE received in the Access-Accept  
53 message. If no shared secret was sent, the PDSN shall attempt to use a statically configured  
54 IKE pre-shared secret if one exists.  
55

1 If the PDSN does not receive the 3GPP2 security level attribute from the home RADIUS server,  
 2 and an IPsec security association to the HA already exists, the PDSN shall continue to use the  
 3 same security association. If no security association exists, then the PDSN shall follow local  
 4 security policy.

5  
 6 If reverse tunneling is supported by the Home Agent as indicated by the RADIUS server in the  
 7 *3GPP2 Reverse Tunnel Specification* attribute, IPsec security is authorized for tunneled data,  
 8 and the mobile requests reverse tunneling, then the PDSN will provide security on the reverse  
 9 tunnel.

10  
 11 The PDSN shall not delete existing IPsec security associations to a HA if the home RADIUS  
 12 server does not authorize security for the mobile. This is because IPsec should be authorized  
 13 per PDSN-HA pair and thus other mobiles may be using the same IPsec security association.  
 14 When the PDSN determines that an IPsec security association to protect control messages has  
 15 already been established to the Home Agent, the PDSN shall ensure the IPsec security  
 16 association is maintained throughout the Mobile IP registration lifetime by periodically refreshing  
 17 the security association. The PDSN shall not forward a MIP RRQ to the HA unless an IPsec  
 18 security association exists first, if the home network authorizes IPsec services. The PDSN shall  
 19 send a failed MIP RRP to the mobile station if the RADIUS Access-Reject is received or if it is  
 20 unable to establish an IPsec security association to the HA and IPsec security is authorized by  
 21 the home RADIUS server.

22  
 23 The home RADIUS server will hide pre-shared secrets for IKE using a method based on the RSA  
 24 Message Digest Algorithm MD5 [RFC 1321] as described in Section 3.5 of RFC 2868.

25  
 26 The PDSN shall comply with the specifications in IKE [RFC 2409] and the Annexes A and B in  
 27 this specification.

28  
 29 In the case of a carrier owned HA, the PDSN must have a security association with an IMT-2000  
 30 HA in order for a registration request to be successfully processed. The security association may  
 31 formally be via IPsec (e.g., ESP or AH) or via Mobile IP HA-FA authentication extension<sup>7</sup>.

### 32 **6.2.5 Ingress Address Filtering**

33 The PDSN shall perform filtering on the source address for packets originating from the mobile  
 34 station to ensure that the mobile station is using address(es) assigned by the Home Agent and  
 35 for which the registration lifetime has not expired. If a mobile station uses an address not  
 36 assigned by the Home Agent, and is not a MIP RRQ or Agent Solicitation, then the PDSN shall  
 37 discard the packet, and send an LCP Configure-Request to restart the PPP session<sup>8</sup>.

### 38 **6.3 Home Agent Requirements**

39 The Home Agent shall support basic MIP [RFC 2002-2006], reverse tunneling [RFC 2344], and  
 40 Mobile IP NAI extension [RFC 2794]. In order to provide public network access and to provide  
 41 private network access across the public network, the HA shall use a globally routable and visible  
 42 care-of-address.

---

<sup>7</sup> This requirement is to prevent users from using collocated COA from high speed interfaces or other interfaces external to an access service provider. Such access circumvents accounting and could result in malicious overloading of the carrier owned HA that adversely affects from wireless data service of users accessing via air interfaces which are subject to charging.

<sup>8</sup> The reason to restart PPP is because the user could have started a Simple IP session during a previous dormant handoff to another PDSN and returned; in this case the current PDSN would not know the mobile station had invoked Simple IP and received another IP address. Thus, restarting PPP will force the Simple IP session to get a topologically correct address.

### 1 **6.3.1 Multiple Registrations**

2 The Home Agent shall support:

- 3 ▪ Multiple registrations for the same NAI using different static addresses
- 4 ▪ Multiple registrations for different NAIs using static or dynamic address assignments

### 5 **6.3.2 IP Security Support**

6 The HA shall determine which type of security associations (if any) are required with a PDSN.  
7 The HA shall use the same security policy as specified in the home RADIUS server and returned  
8 to the PDSN in the 3GPP2 Security Level attribute.

9  
10 Security associations may be authorized for MIP control and/or payload tunnels. Also, IKE  
11 negotiation results in all mobile stations on a given PDSN belonging to the same HA receiving  
12 the same security between the PDSN and HA for either registration messages and/or tunneled  
13 data.

14  
15 The HA shall save the 'S' key received from Home RADIUS servers. Each 'S' key shall have a  
16 lifetime set by Home RADIUS server.

17  
18 When an IKE request is received, the HA shall validate the timestamp in the KeyID field.

19 Each HA shall have a configurable allowable time skew to be used to validate the freshness of  
20 'K'. This timestamp eliminates the possibility of re-using a previously generated 'K' value while  
21 'S' is still valid on the HA.

22  
23 The Home Agent shall maintain expired 'S' keys for a configurable amount of time. This expired  
24 key shall be used when KeyIDs are received, that refer to the expired 'S' key, but falls within the  
25 allowable time skew.

26  
27 If there is no previously assigned 'S' key or if the timestamp in the KeyID is greater than the 'S'  
28 expiration time, the HA will send a RADIUS Access-Request message to Home RADIUS server.  
29 That Access-Request shall contain the 'S' Request Attribute that has one of the possible values:

- 30
- 31 • The HA requests a 'S' for IKE.
- 32 • The HA does not request a 'S' for IKE.
- 33

34 The HA shall compute the pre-shared key using KeyID (Annex C) and the 'S' key (see section  
35 6.2.4). The HA shall check the 'S' key indexed by Home RADIUS server IP address. If the 'S'  
36 key is not found, HA shall request a secret key 'S' from the Home RADIUS server in an Access-  
37 Request by using a concatenation of the PDSN's care of address and home agent address  
38 placed in the user name attribute. The Access-Accept from Home RADIUS server shall include  
39 'S' key and its lifetime. The security method used between the HA and the Home RADIUS  
40 server is outside the scope of this specification.

41  
42 The HA-Home Radius may encrypt S-key and S-Lifetime using a method based on the RSA  
43 Message Digest Algorithm MD5 [RFC 1321] as described in Section 3.5 of RFC 2868.

### 44 **6.3.3 Dynamic Home Address Assignment**

45 The mobile station may send the home agent a MIP RRQ with a 0.0.0.0 home address. If the  
46 Home Agent successfully authenticates the MIP RRQ, the Home Agent shall assign a home  
47 address to the mobile station. The assigned address shall be inserted in the home address field  
48 of the MIP RRP. The Home Agent shall release the home address when the registration expires.

### 49 **6.3.4 Authentication**

50 Based on the policy of the home network, the HA may optionally process the MN-AAA. If the HA  
51 policy dictates that the HA must process the MN-AAA authentication extension, then the HA shall

1 authenticate the registration by sending a RADIUS Access-Request to the Home RADIUS server  
 2 with the following:

- 3
- 4       User-Name (1) = MN-NAI field in the MN-NAI Extension
- 5       CHAP-Password (3) =
- 6            CHAP Ident field = High-order byte of the Challenge Field in the MN-FA Challenge
- 7            Extension
- 8            String field = Authenticator field from the MN-AAA Extension
- 9       CHAP-Challenge (60) = MD5 (Preceding MIP RRQ, Type, Length, SPI), followed by the
- 10       least-order 237 bytes of the Challenge Field in the MN-FA Challenge Extension.
- 11       The MD5 checksum is computed over the MIP RRQ data preceding the MN-AAA
- 12       Extension and the Type, Length, SPI fields of the MN-AAA Extension.
- 13

#### 14 **6.4 RADIUS Server Requirements**

15 See Section 5.3.

16

17 The local RADIUS server shall also support, and the broker and home RADIUS server should  
 18 support, the following attributes in Annex C:

- 19
- 20   ▪ IKE Pre-shared Secret Request Attribute
- 21   ▪ Security Level Attribute
- 22   ▪ Reverse Tunnel Specification
- 23   ▪ Differentiated Services Class Attribute
- 24   ▪ Pre-Shared Secret Attribute
- 25   ▪ Correlation ID Attribute
- 26   ▪ Home Agent Attribute
- 27   ▪ KeyID Attribute
- 28

29 The Home RADIUS server shall also support sending the secret 'S' key and its lifetime to the HA  
 30 using the RADIUS Access-Accept message.

#### 31 **6.5 Mobile Station Requirements**

32 The mobile station may optionally support Mobile IP. If the mobile station wants to use Mobile IP,  
 33 the mobile station shall use packet data service option 33 as specified in TIA/EIA/IS-707-A-2.12.

##### 34 **6.5.1 PPP Session**

35 The mobile station shall use PPP as the data link protocol for Mobile IP. The mobile station may  
 36 support multiple Mobile IP home addresses over a single PPP session.

##### 37 **6.5.1.1 Establishment**

38 Same as Section 5.4.1.1.

##### 39 **6.5.1.2 Termination**

40 Same as Section 5.4.1.2.

##### 41 **6.5.1.3 Authentication with CHAP**

42 The mobile station should not use CHAP for Mobile IP. When the mobile station receives a LCP  
 43 Configuration-Request requesting CHAP authentication, the mobile station should reply with a  
 44 LCP Configure-Reject requesting no CHAP authentication. The PDSN will re-send an LCP  
 45 Configure-Request without the authentication option after receiving the LCP Configure-Reject  
 46 (CHAP) from mobile stations. Mobile stations shall respond with an LCP Configure-Ack as  
 47 described in RFC 1661.

1  
2 If CHAP is performed, performance degradation will occur as the result of an unnecessary  
3 RADIUS traversal.

4  
5 Note that the FAC shall be performed regardless of whether or not CHAP is performed.

#### 6 **6.5.1.4 Addressing with IPCP**

7 If the mobile station uses a static home address or a dynamic home address assigned through  
8 Mobile IP, the mobile station shall not use the IP-Address Configuration Option [RFC 1332]. On  
9 subsequent PPP establishments while maintaining a MIP registration, the mobile station shall  
10 omit the option<sup>9</sup>. Since the PDSN will not support RFC 2290, if the mobile station uses Mobile  
11 IPv4 Configuration Option, the PDSN will reply with an IPCP Configure-Reject.

#### 12 **6.5.1.5 Compression**

13 Same as Section 5.4.1.5.

#### 14 **6.5.1.6 PPP Framing**

15 Same as Section 5.4.1.6.

### 16 **6.5.2 MIP Registration**

#### 17 **6.5.2.1 Agent Discovery**

18 Immediately after PPP is established, the mobile station may send Agent Solicitations. In this  
19 case, the mobile station should use the same procedure as described in Section 2.4 of RFC 2002.  
20 If the mobile station does not have a home address, the mobile station shall use zero in the  
21 Source IP Address field of the IP packet that contains the Agent Solicitation. The Agent  
22 Advertisement received in response to the Agent Solicitation will contain the Foreign Agent  
23 Challenge.

#### 24 **6.5.2.2 Registration Messages**

25 Upon receiving Agent Advertisements, the mobile station shall send a Mobile IP RRQ.

26  
27 If the mobile station uses a static home address, the mobile station shall insert the address into  
28 the home address field of the Mobile IP RRQ.

29  
30 If the mobile station wants a dynamic home address, the mobile station shall use zero in the  
31 Home Address field of the Mobile IP RRQ, and the mobile station shall use zero in the Source IP  
32 Address field of the IP packet that contains the Mobile IP RRQ. In this case the NAI is used to  
33 identify the mobile station. The mobile station shall obtain a home address in the Mobile IP RRP.  
34 On subsequent re-registrations while retaining the same home address, the mobile station shall  
35 insert the assigned address into the home address field of the Mobile IP RRQ.

36  
37 If the mobile station desires reverse tunneling, the mobile station shall set the T-bit in the Mobile  
38 IP RRQ.

39  
40 If the mobile station and PDSN negotiate in IPCP to use Van Jacobson header compression,  
41 then the mobile station shall not set the 'V' bit in the RRQ.

---

<sup>9</sup> If the mobile station that uses Mobile IP uses the IP-Address Configuration Option [RFC-1332] to indicate the home address, the PDSN will consider it as a mobile station using Simple IP service and send a NAK with an alternative address to the mobile station. The mobile station will respond with an IP configure request with the alternative address.

1 **6.5.2.3 MIP Extensions**

2 The mobile station shall include the MN-FA Challenge Extension [RFC 3012], MN-AAA  
3 Extension [RFC 3012], and MN-NAI Extension [RFC 2794]. The mobile station shall use a static  
4 HA address and shall include the MN-HA Authentication Extension in the RRQ because the  
5 mobile station shares a security association with the HA. The mobile station's processing of the  
6 MN-HA Authentication Extension is specified in RFC 3012. Because advertisements are rarely  
7 sent to save air resources, the mobile station should use the challenge value contained in the  
8 last received RRP in the case of re-registrations as described in RFC 3012.

9  
10 The mobile station shall compute the MN-AAA Extension, according to RFC 3012, based on the  
11 shared secret the mobile station has with the home RADIUS server. The mobile station shall  
12 compute the MN-HA Authentication Extension, according to RFC 2002, based on the shared  
13 secret the mobile station has with the HA. The mobile station may use the same shared secret  
14 or different shared secrets in the computation of the MN-AAA Extension and MN-HA  
15 Authentication Extension. This will be coordinated between the mobile station and its home  
16 network.

17 **6.5.2.4 Private Network Support**

18 If the mobile station wants private network access through Mobile IP, the mobile station shall use  
19 reverse tunneling.

20

## 1 **7 Mobility Management**

### 2 **7.1 Mobility within Radio Network**

3 In this specification the term "handoff" is defined to mean continuity of some state during an  
4 interface change from one entity to another. In the absence of any continuity of state  
5 whatsoever, this specification will not refer to such interface changes as "handoffs".

### 6 **7.2 PCF to PCF Handoff**

7 The link layer mobility management function is used to manage the change of the R-P session  
8 point of attachment while maintaining the PPP session and IP address(es). The R-P session  
9 point of attachment is the PCF. When a mobile station moves from one PCF to another PCF, a  
10 new R-P session is required to be setup for every packet data session.

11

12 PCF to PCF handoff may happen while a mobile station is active or dormant. The purpose of  
13 dormant PCF handoff is to maintain the PPP session while a mobile station is dormant while  
14 minimizing the use of airlink resources.

15

16 The PCF to PCF handoff involves:

17

- 18 ▪ PDSN selection
- 19 ▪ New R-P session setup
- 20 ▪ Previous R-P session tear down

21

22 The new PCF triggers a new R-P session setup. If the PDSN selected is the same (current)  
23 PDSN for the mobile station, then the PDSN triggers a release of the previous R-P session. If a  
24 different PDSN is selected, the old R-P session will expire, unless the mobile station returns to  
25 the previous PDSN before the R-P session expires. During PCF to PCF handoff, the selection of  
26 the same PDSN should be given priority in order to maintain the PPP session to the mobile  
27 station. If a different PDSN is selected and the mobile station still desires packet data service,  
28 then a new PPP session must be established.

29

30 Each PCF will be uniquely identified by the combination of the System ID (SID), Network ID  
31 (NID), and Packet Zone ID (PZID). At handoff the new PCF will perform PDSN selection and will  
32 forward the previous PCF's SID/NID/PZID and the current SID/NID/PZID to the selected PDSN.  
33 The PDSN will use this information to determine whether Mobile IP re-registration is required for  
34 the mobile station. If re-registration is required, the PDSN will re-negotiate PPP and will then  
35 send Agent Advertisements.

### 36 **7.3 PDSN to PDSN Handoff**

37 Mobile IP provides the IP layer mobility management function that maintains persistent IP  
38 addresses across PDSNs. There is no similar IP layer mobility management function support  
39 between PDSNs for Simple IP service. For Mobile IP mobile stations, in order to maintain  
40 persistent IP addresses, the mobile station will effect a PDSN to PDSN handoff by registering  
41 with its Home Agent as per RFC 2002 with extensions as outlined in Section 6 above.

42

43 A PDSN to PDSN handoff requires the mobile station be active or to transition to the active  
44 state. The PDSN to PDSN handoff for Mobile IP involves:

45

- 46 ▪ Establishment of new PPP session
- 47 ▪ Detection of new Foreign Agent via the Agent Advertisement Message
- 48 ▪ Authentication by RADIUS infrastructure
- 49 ▪ Registration with the Home Agent

1  
2

## 1 **8 Quality of Service (QoS)**

2 This section specifies extensions to the Simple IP and Mobile IP services. QoS in this  
 3 Specification is limited to support for differentiated services. This extension includes  
 4 differentiated services behavior of the mobile station and PDSN, and 3GPP2 Differentiated  
 5 Service Class Options indicated in the user's RADIUS profile. The 3GPP2 Differentiated Service  
 6 Class Options specify groupings of differentiated services classes.

### 7 **8.1 Differentiated Services Specification**

8 The mobile station may optionally support, and the PDSN should support, differentiated services  
 9 as defined in:

- 10
- 11 ▪ Definition of the Differentiated Services Field (DS Field) in the IPv4 and IPv6 Headers [RFC  
 12 2474];
- 13 ▪ An Architecture for Differentiated Services [RFC 2475];
- 14 ▪ An Expedited Forwarding PHB [RFC 2598];
- 15 ▪ Assured Forwarding PHB Group [RFC 2597].

### 16 **8.2 PDSN Requirements for Differentiated Services**

#### 17 **8.2.1 Service Specification**

18 When a mobile station has marked packets with a differentiated services class, the PDSN may  
 19 optionally accept the marking or may remark the packet based on the user profile's 3GPP2  
 20 Differentiated Service Class Options from the home RADIUS server. When the mobile station  
 21 has not marked the packets, the PDSN may optionally mark packets from the mobile station to  
 22 specific differentiated service classes based on the user profile's 3GPP2 Differentiated Service  
 23 Class Options. The user profile may indicate no differentiated services are authorized for the  
 24 user, and if so, the PDSN will mark the user's packets as configured by the service provider  
 25 network.

26

27 For Mobile IP service, the Home Agent will copy the differentiated services class of each packet  
 28 to the differentiated service field of the tunnel, in accordance with RFC 2002. For Mobile IP  
 29 service with reverse tunneling enabled, the PDSN shall determine the differentiated services  
 30 field of each tunneled packet to the Home Agent based on the user profile and other  
 31 considerations specified in this section.

32

33 The PDSN shall send packets received from the IP network for a mobile station onto the R-P  
 34 session for the mobile station in accordance with differentiated class behavior of the packet and  
 35 the user profile's 3GPP2 Differentiated Service Class Options. The PPP frames that carry the  
 36 user packets are encapsulated in GRE packets, which in turn are carried over IP. PPP frame  
 37 boundaries may or may not be aligned with GRE packets.

38

39 The PDSN shall use sequential numbering in the GRE packet header, to insure sequential  
 40 delivery of packets over the R-P interface, if at least one of the following events occur:

- 41
- 42 ▪ The PDSN is configured to send GRE packets that contain incomplete PPP frames or  
 43 multiple PPP frames.
- 44 ▪ The mobile station negotiates a PPP payload compression algorithm that requires PPP  
 45 frames to be delivered in sequence.
- 46 ▪ The mobile station negotiates Van Jacobson TCP/IP header compression in which the  
 47 Connection ID may be compressed.
- 48

49 If the PDSN uses sequential numbering in the GRE packet header, the PDSN shall indicate one  
 50 and only one differentiated service class for all IP packets of the R-P session based on the user

1 profile's 3GPP2 Differentiated Service Class Options from the home RADIUS server. The  
2 3GPP2 provider must insure that it does not exceed its service level agreements (SLA) with its  
3 supporting ISPs; however, the procedures to insure that SLAs are satisfied are beyond the scope  
4 of this specification.

5  
6 For packets received from the RN, the PDSN shall not process the differentiated services class  
7 field associated with the R-P interface.

### 8 **8.2.2 3GPP2 Differentiated Service Class Option**

9 As indicated above, the 3GPP2 Differentiated Service Class Options specify groupings of  
10 differentiated services classes. For some 3GPP2 Differentiated Service Class Options, not all  
11 differentiated service classes may be supported. This option is contained in a user profile  
12 parameter in the home RADIUS server, and is returned to the PDSN in the RADIUS Access  
13 Accept message. The format of the RADIUS attribute is given in Annex C. The actual  
14 parameters associated with these classes, such as classification rules and policing parameters  
15 are configured into the PDSN by the visited access provider, and are not sent in the RADIUS  
16 profile parameter. The method by which carriers agree to the same PDSN configuration  
17 definitions for each class, as well as the method to inform private network owners and ISPs of  
18 these class definitions, is outside the scope of this specification.

### 19 **8.3 RN Requirements for Differentiated Service**

20 The RN may use the Differentiated Service indication from the R-P interface generated by the  
21 PDSN to deliver packets to the mobile station. The RN shall not reorder packets of the same  
22 differentiated service class.

23  
24 The RN does not perform general differentiated services processing functions such as policing,  
25 nor does it examine the actual PPP frame itself to perform additional differentiated services  
26 information beyond those supported by the PDSN.

### 27 **8.4 Mobile Station Requirements for Differentiated Service**

28 The mobile station may support differentiated services or may rely on the network to perform  
29 packet marking.

30

1 **9 Accounting**

2 **9.1 General**

3 Packet Accounting parameters are divided into radio specific parameters collected by the RN,  
 4 and IP network specific parameters collected by the PDSN. The PDSN merges the radio  
 5 specific parameters for a given user session with the IP network specific ones to form a Usage  
 6 Data Record (UDR). After merging, the PDSN will send the UDR to a local RADIUS Server.  
 7 The PDSN will maintain the UDR information until the PDSN receives positive acknowledgment  
 8 from the RADIUS server that the RADIUS server has correctly received the UDR.

9  
 10 The PDSN will formulate one UDR per IP address per mobile station.

11  
 12 The RADIUS server will maintain the UDR until the record is removed by the operator billing  
 13 system. The method by which this is done is beyond the scope of this specification as is the  
 14 summary, reconciliation, and billing process used by the carriers.

15  
 16 The RN sends radio specific parameters in messages called airlink records across the R-P  
 17 interface. Once the PDSN combines these with IP network specific parameters, the UDR is sent  
 18 to the RADIUS server as a RADIUS Accounting-Request message. This is outlined as below in  
 19 Figure 8, and detailed in the subsequent sections.

20

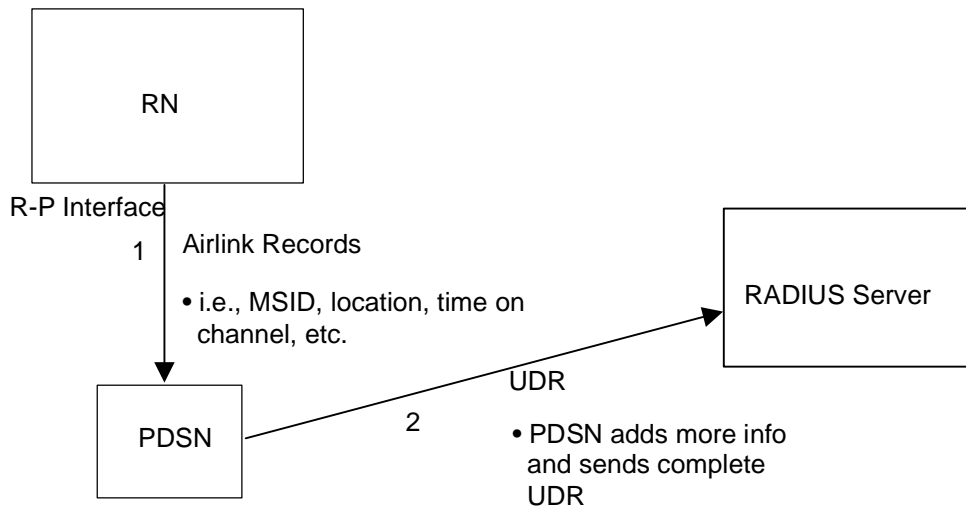

21  
 22  
 23  
 24  
 25  
 26  
 27  
 28

**Figure 7: Accounting Architecture**

Table 5 in Section 9.3 contains a complete listing of UDR attributes. Tables 1-4 contains fields in various air link records generated by the RN. Note that a lower case letter implies a field in an air link record whereas a capital letter implies an attribute in a UDR.

29 **9.2 Airlink Records**

30 The RN generates one of four types of airlink records over the R-P interface:

31  
 32  
 33  
 34

- A Connection Setup when the RN establishes an R-P session.
- An Active Start record when the MS has started to use traffic channel(s).
- An Active Stop record when the MS has stopped using traffic channel(s).

- 1   ▪ A Short Data Burst (SDB) record when a forward or reverse short data burst is exchanged
- 2     with the MS.

3  
4   The R-P Session ID is the PSI used at A10 establishment (session specific extension) and in the  
5   GRE key used on the A10 connection.

6  
7   All the airlink records would include a sequence number initialized to zero at R-P session setup.  
8   The sequence number is unique for a single identification triplet (R-P Session ID, PCF ID, and  
9   MSID). Upon receiving the connection setup airlink record, the PDSN updates the UDR with the  
10   airlink record information and stores the sequence number. The PCF shall increment the  
11   sequence number modulo 256 in the subsequent airlink record transmitted over the  
12   corresponding R-P session. The PDSN will then compare the received sequence number with  
13   the previously stored sequence number (N). If the received sequence number is in the range  
14   from (N+1) modulo 256 to (N+127) modulo 256, inclusive, the PDSN shall act accordingly based  
15   on the information contained in the airlink record, and shall update its stored sequence number.  
16   If the received sequence number is in the range from (N-128) modulo 256 to (N-1) modulo 256,  
17   inclusive, the PDSN shall ignore the message. The same procedure continues for all the  
18   subsequent airlink records, until the closing of the R-P session.

19  
20   Note that in the event of retransmission, the PCF shall retransmit with the same sequence  
21   number, and the PDSN shall not update the UDR if the same sequence number corresponding to  
22   a single identification triplet is received. There should be only one outstanding unacknowledged  
23   airlink record at any given time.

24  
25   Detailed specifications of airlink records are in section 6.2.2.166 of A.S0001-A.

26   **9.2.1 R-P Session Setup Airlink Record**

27   Table 1 contains fields present in R-P Session Setup airlink records.

28

Item	Parameter	Max Payload Length	Format
y1	Airlink Record Type = 1 (Connection Setup)	4	integer
y2	R-P Session ID	4	integer
y3	Airlink Sequence Number	4	integer
a1	MSID	15	string
d3	Serving PCF	4	ip-addr
d4	BSID	12	string

29  
30                   **Table 1: R-P Session Setup Airlink Fields**

31  
32   Each R-P session and each airlink record is indexed via the R-P Session ID.

1 **9.2.2 Active Start Airlink Record**

2 Table 2 contains fields present in Active Start airlink records.

3

Item	Parameter	Max Payload Length	Format
y1	Airlink Record Type = 2 (Active Start)	4	integer
y2	R-P Session ID	4	integer
y3	Airlink Sequence Number	4	integer
e1	User Zone	4	integer
f1	Forward Mux Option	4	integer
f2	Reverse Mux Option	4	integer
f5	Service Option	4	integer
f6	Forward Traffic Type(Primary, Secondary)	4	integer
f7	Reverse Traffic Type(Primary, Secondary)	4	integer
f8	Fundamental Frame Size (0/5/20 ms)	4	integer
f9	Forward Fundamental RC	4	integer
f10	Reverse Fundamental RC	4	integer
f14	DCCH Frame Size (0/5/20ms)	4	integer
i4	Airlink Quality of Service (QoS)	4	integer

4

5

6

**Table 2: Active Start Airlink Fields**

7

If the e1, f1, f2, and/or i4 parameters in Table 2 change during the active session, the RN shall send an Active Stop airlink record, and an Active Start airlink record with the new parameters.

8

9

f1 to f10 are fields from service configuration record.

10

11 **9.2.3 Active Stop Airlink Record**

12 Table 3 contains fields present in Active Stop airlink records.

13

Item	Parameter	Max Payload Length	Format
y1	Airlink Record Type = 3 (Active Stop)	4	integer
y2	R-P Session ID	4	integer
y3	Airlink Sequence Number	4	integer
g8	Active Connection Time in Seconds	4	integer

14

15

**Table 3: Active Stop Airlink Fields**

16 **9.2.4 SDB Airlink Record**

17 Table 4 contains fields present in SDB airlink records.

18

Item	Parameter	Max Payload Length	Format
y1	Airlink Record Type = 4 (SDB)	4	integer
y2	R-P Session ID	4	integer
y3	Airlink Sequence Number	4	integer
y4	Mobile Originated/Mobile Terminated Indicator	4	integer
g10	SDB Octet Count	4	integer

19

Table 4: SDB Airlink Fields

### 9.3 PDSN Usage Data Record (UDR)

The Accounting Session ID is a unique accounting ID created by the PDSN that allows start and stop RADIUS records from a single R-P session to be matched. The Correlation ID is a unique accounting ID created by the PDSN that allows multiple related R-P sessions to be matched.

Table 5 contains the complete UDR and the description of each field.

Item	Parameter	Description
<b>A. Mobile Identifiers</b>		
A1	MSID	Mobile Station ID (e.g., IMSI, MIN, IRM)
<b>B. User Identifiers</b>		
B1	IP Address	IP address of the mobile station.
B2	Network Access Identifier (NAI)	user@domain construct which identifies the user and home network of the mobile station.
<b>C. Session Identifiers</b>		
C1	Account Session ID	A unique accounting ID created by the PDSN that allows stop and start records to be matched in a log file.
C2	Correlation ID	An ID that correlates all accounting sessions authorized for this NAI by this access request
C3	Session Continue	This attribute when set to 'true' means it is not the end of a Session and an Accounting Stop is immediately followed by an Account Start Record. 'False' means end of a session.
<b>D. Infrastructure Identifiers</b>		
D1	MIP Home Agent (HA)	The IP address of the HA
D2	PDSN/FA Address	IP address or other identifier.
D3	Serving PCF	The IP address of the serving PCF
D4	BSID	Base station ID
<b>E. Zone Identifiers</b>		
E1	User Zone	Tiered Services user zone.
<b>F. Session Status</b>		
F1	Forward Mux Option	Forward direction multiplex option
F2	Reverse Mux Option	Reverse direction multiplex option
F5	Service Option	CDMA air interface service option
F6	Forward Traffic Type	Primary or Secondary
F7	Reverse Traffic Type(Primary, Secondary)	Primary or Secondary
F8	Fundamental Frame Size	The fundamental channel has the choice of 5 or 20 ms size. The 5ms frame size allows fast response for short signaling messages (short frame can be decoded quickly). However, depending on the configuration, the fundamental may not be present.
F9	Forward Fundamental RC	
F10	Reverse Fundamental RC	
F11	IP Technology	Identifies Simple IP, Mobile IP, or another technology.
F12	Compulsory Tunnel Indicator	Indicator of invocation of compulsory tunnel established on behalf of MS for providing private network and/or ISP access during a single packet data connection.
F13	Release Indicator	Specifies reason for sending a stop record.
<b>G. Session Activity</b>		
G1	Data Octet Count (Terminating)	The total number of octets in IP packets sent to the user.
G2	Data Octet Count (Originating)	The total number of octets in IP packets sent by the user.
G3	Bad PPP frame count	The total number PPP frames from the mobile station dropped by PDSN due to uncorrectable errors.

G4	Event Time	Indicates start of accounting session or stop of accounting session if part of a RADIUS start message or stop message, respectively. It is also used in a RADIUS interim message to indicate the time of the event which triggered the interim message.
G8	Active Time	The total active connection time on traffic channel in seconds.
G9	Number of Active Transitions	The total number of non-active to Active transitions by the user.
G10	SDB Octet Count (Terminating)	The total number of octets sent to the user via Short Data Bursts.
G11	SDB Octet Count (Originating)	The total number of octets sent by the user via Short Data Bursts.
G12	Number of SDBs (Terminating)	The total number of Short Data Burst transactions.
G13	Number of SDBs (Originating)	The total number of Short Data Burst transactions.
G14	Number of HDLC layer bytes received	The count of all bytes received in the reverse direction by the HDLC layer in the PDSN.
G15	In-Bound Mobile IP Signaling Octet Count	This is the total number of octets in registration requests and solicitations sent by the mobile.
G16	Outbound Mobile IP Signaling Octet Count	This is the total number of octets in registration replies and agent advertisements, sent to the mobile.
<b>I. Quality of Service</b>		
I1	IP Quality of Service (QoS)	The differentiated Services code points associated with the user data
I4	Airlink Quality of Service (QoS)	Identifies airlink QoS associated with the user data. This is currently a priority level in C.S0001-A.

1  
2

**Table 5: Complete UDR**

3 **9.4 Accounting Formats**

4 The RADIUS server will support RADIUS attribute formats as defined in RFC 2138 and RFC  
5 2139. RN parameters transmitted across the R-P interface shall follow the RADIUS format.  
6 Table 6 lists each accounting parameter and its associated RADIUS attribute.

7

8 Note: Attributes of type "26" defined in RFC 2138 and RFC 2139 are vendor specific, and are  
9 used to transport 3GPP2 specific parameters. The default Vendor ID value in Vendor Specific  
10 attributes shall be 5535 defined in IANA in order for cdma2000 packet data service to support  
11 global roaming.

1  
2  
3  
4  
5  
6  
7  
8

RADIUS Attribute Definitions						
Item	Parameter	Type/ Vendor Type	Maximum Payload Length	Format	Field	Special Values
<b>A. Mobile Identifiers</b>						
A1	MSID	31	15	string	Calling_ID	
<b>B. User Identifiers</b>						
B1	IP Address	8	4	ip-addr	Framed IP Address	
B2	Network Access Identifier (NAI)	1	64	string	User-Name	
<b>C. Session Identifiers</b>						
C1	Account Session ID	44	8	string	Acct_Session_Id	ASCII string of session ID
C2	Correlation ID	26/44	8	string	Correlation_Id	ASCII string of correlation ID
C3	Session Continue	26/48	4	integer	3GPP2_Session_cont	0=False, 1=True
<b>D. Infrastructure Identifiers</b>						
D1	MIP Home Agent (HA)	26/7	4	ip-addr	3GPP2_HA_IP_Addr	
D2	PDSN/FA Address	4	4	ip-addr	NAS Address	
D3	Serving PCF	26/9	4	ip-addr	3GPP2_PCF_IP_Addr	
D4	BSID	26/10	12	string	3GPP2_BSID	A number formed from the concatenation of SID+ NID+ BSC ID, where each item is encoded using four hexadecimal upper case ASCII characters.
<b>E. Zone Identifiers</b>						
E1	User Zone	26/11	4	integer	3GPP2_User_ID	Least significant 16 bits hold user zone ID (UZ_ID) next significant 15 bits hold user zone system ID (UZ_SID) and most significant bit always zero. UZ_ID and UZ_SID are defined in IS-638-B.
<b>F. Session Status</b>						
F1	Forward Mux Option	26/12	4	integer	3GPP2_FMUX	
F2	Reverse Mux Option	26/13	4	integer	3GPP2_RMUX	
F5	Service Option	26/16	4	integer	3GPP2_SO	
F6	Forward Traffic Type	26/17	4	integer	3GPP2_FTYPE	0=Primary, 1=Secondary
F7	Reverse Traffic Type(Primary, Secondary)	26/18	4	integer	3GPP2_RTYPE	0=Primary, 1=Secondary
F8	Fundamental Frame Size	26/19	4	integer	3GPP2_FSIZE	0=no fundamental, 1=5ms frame, 2=20ms frame
F9	Forward Fundamental RC	26/20	4	integer	3GPP2_FRC	
F10	Reverse Fundamental RC	26/21	4	integer	3GPP2_RRC	

F11	IP Technology	26/22	4	integer	3GPP2_IP_Tech	1=Simple IP, 2=Mobile IP
F12	Compulsory Tunnel Indicator	26/23	4	integer	3GPP2_Comp_Flag	0=no tunnel 1=non-secure tunnel 2=secure tunnel
F13	Release Indicator	26/24	4	integer	3GPP2_Reason_Ind	Reasons for stop record: 0=unknown 1=PPP/Service timeout 2=Handoff  3=PPP termination 4=Mobile IP registration failure
F14	DCCH Frame Format (0/5/20ms)	26/50	4	integer	3GPP2_F_Size	Frame Sizes: 0/5/20ms

1

**G. Session Activity**

G1	Data Octet Count (Terminating)	43	4	integer	Acct_Output_Octets	
G2	Data Octet Count (Originating)	42	4	integer	Acct_Input_Octets	
G3	Bad PPP Frame Count	26/25	4	integer	3GPP2_Bad_Frame_Count	
G4	Event Time	55	4	time	3GPP2_Event_Timestamp	See Annex C
G8	Active Time	26/49	4	integer	3GPP2_Active_Time	
G9	Number of Active Transitions	26/30	4	integer	3GPP2_Num_Active	
G10	SDB Octet Count (Terminating)	26/31	4	integer	3GPP2_SDB_Input_Octets	
G11	SDB Octet Count (Originating)	26/32	4	integer	3GPP2_SDB_Output_Octets	
G12	Number of SDBs (Terminating)	26/33	4	integer	3GPP2_NumSDB_Input	
G13	Number of SDBs (Originating)	26/34	4	integer	3GPP2_NumSDB_Output	
G14	Number of HDLC layer bytes received	26/43	4	integer	3GPP2_Num_Bytes_Received_Total	The count of all bytes received in the reverse direction by the HDLC layer in the PDSN.
G15	In-Bound Mobile IP Signaling Octet Count	26/46	4	Integer	3GPP2_Mobile_IP_Signaling_In-Bound_Count	This is the total number of octets in registration requests and solicitations sent by the mobile.
G16	Outbound Mobile IP Signaling Octet Count	26/47	4	Integer	3GPP2_Mobile_IP_Signaling_Out-Bound_Count	This is the total number of octets in registration replies and agent advertisements, sent to the mobile.

2

**I. Quality of Service**

I1	IP Quality of Service (QOS)	26/36	4	integer	3GPP2_IP_QOS	0=Best Effort 10=AF11 12=AF12 14=AF13 18=AF21 20=AF22 22=AF23 26=AF31 28=AF32 30=AF33 34=AF41 36=AF42 38=AF43 46=EF
I4	Airlink Quality of Service (QOS)	26/39	4	integer	3GPP2_Air_QOS	Least significant 4 bits hold the QoS priority as defined in C.S0001-A in the subscriber profile.

1 **Y. Airlink Record Specific Parameters**

Y1	Airlink Record Type	26/40	4	integer	3GPP2_Airlink_Record_Type	1=Connection Setup 2=Active Start 3=Active Stop 4=SDB Record
Y2	R-P Session ID	26/41	4	integer	3GPP2_R-P_Session_ID	
Y3	Airlink Sequence Number	26/42	4	Integer	3GPP2_Airlink_Sequence_Number	
Y4	Mobile Originated / Mobile Terminated Indicator	26/45	4	Integer	3GPP2_Mobile_Terminated_Originated_Indicator	0=Mobile Originated 1=Mobile Terminated

2 **Z. Container**

Z1	Container	26/6	Variable	string	3GPP2_Container	See Annex C
----	-----------	------	----------	--------	-----------------	-------------

3  
4  
5 **Table 6: Accounting Parameter Attribute RADIUS Definitions**

## 1 **9.5 PDSN Procedures**

2 There are several kinds of events that cause the PDSN to take some action:

- 3
- 4 ▪ Reception of R-P session setup airlink record.
- 5 ▪ Data service establishment on the PDSN. This includes a PPP session and packet service
- 6 (Simple IP or Mobile IP).
- 7 ▪ Data service termination on the PDSN. This includes releasing the PPP session.
- 8 ▪ Arrival of forward direction or reverse direction user data.
- 9 ▪ Reception of Active Start airlink record.
- 10 ▪ Reception of Active Stop airlink record.
- 11 ▪ Reception of SDB airlink record.
- 12 ▪ Interim record trigger.
- 13 ▪ Stop record trigger.
- 14 ▪ Time of day timer expiry.

15

16 A UDR is associated with an NAI, IP address pair within a PPP session. A UDR stores the

17 accounting information for an NAI, IP pair for the duration of the packet data service in a single

18 PDSN. RADIUS accounting messages are generated from the information in the UDR. The

19 Correlation ID is used to match different accounting records (accounting session IDs) across R-P

20 sessions on a single PDSN. One correlation ID is maintained for the life of a UDR. The Account

21 Session ID is used to match a single RADIUS Start and Stop pair. The R-P Session ID

22 corresponds to an R-P connection. A new R-P connection due to intra-PDSN handoff between

23 PCFs would result in a new R-P Session ID. The MSID is used to select the proper UDR after an

24 intra-PDSN handoff. One R-P Session ID may be associated with multiple simultaneous NAI, IP

25 pairs in the PDSN.

26

27 Airlink records are only associated with an R-P session. The PDSN matches the R-P Session ID

28 in the airlink record to the R-P Session ID in the appropriate UDR(s). If more than one UDR

29 matches, the actions are applied to all UDRs.

30

31 Some events cause certain UDR fields to change in the middle of a session. When this happens,

32 one of two approaches must be taken: (1) a container attribute as specified in Annex C is created

33 and the changed fields embedded in that container attribute. This allows the UDR to continue to

34 accumulate accounting information after an event without transmitting a RADIUS message.

35 Alternatively (2), the PDSN may send a RADIUS-Stop record to capture accounting data before

36 the event, followed by a RADIUS-Start record with the new field values. In fact, a PDSN may

37 send a RADIUS-Stop and RADIUS-Start anytime during a single session as long as no

38 accounting data is lost. In these cases, the PDSN shall send the same Correlation ID in both the

39 RADIUS-Start and RADIUS-Stop records.

40

41 The subsequent sections specify the actions to take for each event.

### 42 **9.5.1 R-P Session Setup Airlink Record Arrives**

43 When the PDSN receives a Connection Setup Airlink record as a result of a handoff, then the

44 PDSN shall:

- 45
- 46 ▪ Use the MSID to find the correct UDR.
- 47 ▪ Either, create a new Container attribute in the UDR with Container-Reason ← Handoff,
- 48 Event-timestamp ← current time and attributes D2, D3, D4, G1, G2, G3, and G8-16.
  - 49 • Use information received from the RN to fill the following fields: D2, D3, and D4.
  - 50 • Zero fields G1, G2, G3, G8-16.
- 51 ▪ Or, add a Session Continue attribute in the UDR with the value set to 1 (True).
  - 52 • Send a RADIUS Accounting-Request Stop record based on the current UDR.
  - 53 • Use information received from the RN to fill the following fields: D2, D3, and D4.

- 1       • Zero fields G1, G2, G3, and G8-16.  
 2       • Send a RADIUS Accounting-Request Start record containing a new Accounting Session  
 3       ID and same Correlation ID.  
 4

5       Otherwise, the PDSN shall use information it receives from the RN to fill the following fields of  
 6       the new UDR(s):

- 7  
 8       ▪ A1, D3, and D4.  
 9

10      The PDSN will populate the remaining fields of the UDR at a later point in time.

11      **9.5.2 Packet Data Service Establishment**

12      After the PDSN establishes packet data service (i.e., Simple IP or Mobile IP service) to the  
 13      mobile station, the PDSN shall:

- 14  
 15      ▪ Fill the following fields: B1, B2, C1, C2, D1, D2, F11, F12, and I1.  
 16      ▪ Zero fields G1, G2, G3, and G8-13.  
 17      ▪ Send a RADIUS Accounting-Request Start record based on the current UDR.

18      **9.5.3 Packet Data Service Termination**

19      After the PDSN terminates data service to the mobile station the PDSN shall:

- 20  
 21      ▪ Add a Session Continue attribute in the UDR with the value set to 0 (False).  
 22      ▪ Send a RADIUS Accounting-Request Stop record based on the current UDR.  
 23      ▪ Delete the UDR after receiving acknowledgment from the RADIUS server that it has  
 24      successfully received the UDR.  
 25      ▪

26      **9.5.4 User Data Through PDSN**

27      For any user data processed by the PDSN in the forward direction, the PDSN shall:

- 28  
 29      ▪ Increment G1 by the number of octets in IP packets sent to the user.  
 30      ▪ Increment G16 by the number of octets in Mobile IP signaling sent to the user.  
 31

32      For any user data processed by the PDSN in the reverse direction, the PDSN shall:

- 33  
 34      ▪ Increment G2 by the number of octets in IP packets sent by the user.  
 35      ▪ Increment G14 by the number of octets received at the HDLC layer.  
 36      ▪ Increment G15 by the number of octets in Mobile IP signaling sent by the user.

37      **9.5.5 Active Start Airlink Record Arrives**

38      When the PDSN receives an Active Start airlink record from the RN, the PDSN performs the  
 39      following.

40  
 41      If the UDR is new (some fields are blank), the PDSN shall:

- 42  
 43      ▪ Set UDR fields according to airlink record:  $E1 \leftarrow e1$ ,  $F1-F10 \leftarrow f1-f10$ ,  $F14 \leftarrow f14$ , and  $I4 \leftarrow$   
 44       $i4$   
 45

46      Otherwise, if airlink record indicates parameters E1, F1, F2, or I4 have changed, the PDSN shall:

- 47  
 48      ▪ Either, create a new Container attribute in the UDR with Container-Reason  $\leftarrow$  Parameter  
 49      change, Event-timestamp  $\leftarrow$  current time and attributes E1, G1, G2, G3, G8-G16, and I4.

- 1       • Set UDR fields according to airlink record.  $E1 \leftarrow e1$ ,  $F1 \leftarrow f1$ ,  $F2 \leftarrow f2$ ,  $I4 \leftarrow i4$  and zero
- 2       fields G1, G2, G3, and G8-16.
- 3       ▪ Or, add a Session Continue attribute in the UDR with the value set to 1 (True).
- 4       ▪ Send a RADIUS Accounting-Request Stop record based on the current UDR.
- 5       ▪ Set UDR fields according to airlink record.  $E1 \leftarrow e1$ ,  $F1 \leftarrow f1$ ,  $F2 \leftarrow f2$ ,  $I4 \leftarrow i4$  and zero
- 6       fields G1, G2, G3, and G8-16.
- 7       ▪ Send a RADIUS Accounting-Request Start record based on UDR containing a new Account
- 8       Session ID and same Correlation ID.

9  
10 Finally, the PDSN shall increment G9 by one.

#### 11 **9.5.6 Active Stop Airlink Record Arrives**

12 When the PDSN receives an Active Stop airlink record from the RN, the PDSN shall:

- 13
- 14       ▪ Increment G8 by the value of g8.

#### 15 **9.5.7 SDB Airlink Record Arrives**

16 When the PDSN receives an SDB airlink record from the RN, the PDSN performs the following:

17  
18 If the mobile originated / mobile terminated indicator is equal to one (mobile terminated SDB),  
19 the PDSN shall:

- 20
- 21       ▪ Increment G10 by the value of g10.
- 22       ▪ Increment G12 by one.
- 23

24 If the mobile originated / mobile terminated indicator is equal to zero (mobile originated SDB),  
25 the PDSN shall:

- 26
- 27       ▪ Increment G11 by the value of g10.
- 28       ▪ Increment G13 by one.

#### 29 **9.5.8 Interim Record Trigger**

30 When the Interim Record Trigger initiates, the PDSN shall send a RADIUS Accounting-Request  
31 Interim record based on current UDR. The Interim Record Trigger is an operator configurable  
32 time interval since the last RADIUS accounting record was sent for a UDR.

#### 33 **9.5.9 Stop Record Trigger**

34 Additional conditions may trigger a RADIUS Accounting Request Stop record to be sent by the  
35 PDSN such as:

- 36
- 37       ▪ When the size of the RADIUS accounting record to be sent for the UDR exceeds an operator
- 38       configurable threshold.
- 39       ▪ Any time during a session as an implementation dictates.
- 40

41 When the Stop Record Trigger initiates, the PDSN shall add a Session Continue attribute in the  
42 UDR with the value set to 1 (True). Send a RADIUS Accounting-Request Stop record based on  
43 current UDR and fields G1, G2, G3, and G8-16 are zeroed. Immediately afterwards, the PDSN  
44 shall send a RADIUS Accounting-Request Start record based on current UDR containing a new  
45 Account Session ID and same Correlation ID.

#### 46 **9.5.10 Time of Day Timer Expires**

47 The time of day timer(s) shall be a set of operator configurable parameters for certain time(s) of  
48 day. These timers may be used, for example, to delineate peak and off-peak billing hour  
49 boundaries.

1  
2  
3  
4  
5  
6  
7  
8  
9  
10  
11  
12

When an accounting time of day timer expires, the PDSN shall:

- Either, create a new Container attribute in the UDR with Container-Reason ← Tariff Boundary, Event-timestamp ← current time and attributes G1, G2, G3, and G8-G16.
  - Zero fields G1, G2, G3, and G8-16.
- Or, add a Session Continue attribute in the UDR with the value set to 1 (True) S
  - End a RADIUS Accounting-Request Stop record based on the current UDR.
  - Zero fields G1, G2, G3, and G8-16.
  - Send a RADIUS Accounting-Request Start record based on current UDR containing a new Account Session ID and same Correlation ID.

1 **10 R-P Interface**

2 The PDSN and RN will support the R-P interface defined as A10 and A11 interfaces of A.S0001-  
3 A.

4  
5 This document has been completed between standardization of A.S0001 and A.S0001-A. This  
6 document incorporates key issues identified in A.S0001 that are to be standardized in A.S0001-A.  
7 This document does not include all features and fixes added to A.S0001-A, nor attempt to  
8 identify potential issues with regards to A.S0001 and A.S0001-A interworking. For example, if the  
9 RN supports a prior version of the R-P interface, as for example defined in A.S0001, the mobility  
10 detection (i.e., handoff) by the PDSN is not optimal. The overall system performance may suffer.

11  
12  
13

## 1 **11 Radio Network Requirements**

2 The PDSN interfaces to the Radio Network only through the R-P interface and there are no RN  
3 dependent signaling messages transmitted to the PDSN. However, there are some general  
4 requirements placed on the RN:

- 5
- 6 ▪ Each RN will be connected to at least one PDSN.
- 7 ▪ The RN will relay PPP frames between the MS and PDSN.
- 8 ▪ The RN will establish an R-P session for each MS initiating a packet data session.
- 9 ▪ The RN will terminate the R-P session if the MS terminates a packet data session or the MS  
10 indicates that is no longer reachable.
- 11 ▪ The RN will manage radio resources to exchange user data with mobile stations.
- 12 ▪ The RN will buffer user data from the PDSN when radio resources are not in place or  
13 insufficient to support the flow of data.
- 14 ▪ The RN will pass octets between the mobile station and PDSN without any framing  
15 conversion.

### 16 **11.1 R-P General Handoff Requirements**

17 These requirements cover the duration of a packet data session and include periods when the  
18 RN does not allocate radio resources to the MS (if such a dormant/standby capability is  
19 supported by the RN).

- 20
- 21 ▪ The RN will have the capability to determine when an MS enters its coverage area.
- 22 ▪ The RN will be able to determine with which PDSN an MS currently has a PPP session, if a  
23 PPP session already exists.
- 24 ▪ During a packet data session, an MS may move outside the coverage area on an RN into the  
25 coverage area of another RN. If the old and new RN have connectivity to the same PDSN,  
26 the RNs will release and re-establish the R-P session so that it connects the new RN serving  
27 the MS and the PDSN in such a way that the MS maintains the same PPP session.
- 28 ▪ During a packet data session, an MS may move outside the coverage area on an RN into the  
29 coverage area of another RN. If the old and new RN do not have connectivity to the same  
30 PDSN, the new RN will immediately establish a new R-P session to a new PDSN.

31  
32 Specific handoff procedures for the R-P are not called out in this specification but can be found  
33 in A.S0001.

34

1 **12 Air Interface**

2 The mobile station and RN will support the air interface as specified in:

3

- 4 • C.S0001-A Introduction to cdma2000 Standards for Spread Spectrum Systems
- 5 • C.S0002-A Physical Layer Standard for cdma2000 Spread Spectrum Systems
- 6 • C.S0003-A Medium Access Control (MAC) Standard for cdma2000 Spread Spectrum
- 7 Systems
- 8 • C.S0004-A Signaling Link Access Control (LAC) Standard for cdma2000 Spread
- 9 Spectrum Systems
- 10 • C.S0005-A Upper Layer (Layer 3) Signaling Standard for cdma2000 Spread Spectrum
- 11 Systems

12

## 1 **Annex A: IKE/ISAKMP Payloads**

2 Interoperability between HA and PDSN/FA implementations is a major goal of this specification.  
 3 This Annex addresses ISAKMP payloads in which multiple options exist. The following  
 4 requirements must be met by the PDSN and HA, assuming IP security between the HA and  
 5 PDSN/FA is required. Payloads in which no options exist do not appear in this Annex.

6  
 7 Note: If the HA (home network) does not require any security then Annex A does not apply nor  
 8 does it apply to mobile stations using collocated COA for Mobile IP.

### 9 10 **ISAKMP Fixed Header**

11  
 12 The PDSN in this specification shall use a Major and Minor Version of 0. The HA shall  
 13 minimally accept Major and Minor Version of 0. This specification does not make use of  
 14 the Fixed Header Authentication (A) bit. Subsequent revisions of this specification will  
 15 allow for other ISAKMP Major and Minor Versions to accommodate advances in  
 16 ISAKMP and IKE standards.

### 17 18 **Security Association Payload:**

19  
 20 All Security Association Payloads will use the IPsec DOI. The Phase 1 ISAKMP Security  
 21 Payload will specify a situation of SIT\_IDENTITY\_ONLY. Phase 2 ISAKMP Security  
 22 Payloads will specify situations of SIT\_IDENTITY\_ONLY for all cases where privacy or  
 23 only authentication applies (as outlined in the PDSN and HA "IP Security" sections of  
 24 this specification).

### 25 26 **Proposal Payload:**

27  
 28 Because the mobile station first makes contact with the PDSN, the PDSN shall be the  
 29 Initiator of the Phase 1 ISAKMP SA. The HA shall be the Responder. The PDSN shall  
 30 propose ISAKMP to the HA for the Phase 1 ISAKMP SA. Non-service provider owned  
 31 HA security policies are outside the scope of this specification, but may reasonably be  
 32 expected to support the same Proposal.

33  
 34 For Phase 2 Quick Mode exchanges, both the PDSN and HA will be Initiators and  
 35 Responders because symmetrical, bi-directional security between PDSN and HA will be  
 36 required. The PDSN and HA shall propose either IPsec AH for message authentication,  
 37 or IPsec ESP for message privacy. The PDSN may choose to use both ESP and AH.

38  
 39 Mobile IP registration control packets and IP in IP tunneled packets may be protected by  
 40 IPsec AH or ESP (or both). Security policies to be used between PDSN and HA in this  
 41 specification will be dictated by the home network not the access provider network. The  
 42 PDSN shall propose two proposals, IPsec ESP and AH. Service provider owned HAs  
 43 shall propose only one Proposal (e.g., IPsec ESP), and the PDSN shall accept this  
 44 proposal. The Home RADIUS may deliver a User Profile to the Foreign RADIUS and  
 45 PDSN that indicates whether security should be supported for IP in IP packets. If the  
 46 Home RADIUS indicates a request for no security on the IP-in-IP tunneled packets, the  
 47 PDSN shall not delete existing IPsec security associations to the HA. This is because  
 48 IPsec should be authorized per PDSN-HA pair and thus other mobiles may be using  
 49 those IPsec security associations.

50  
 51 The SPI shall be four octets.

### 52 53 **Transform Payload:**

1  
2 For Phase 1, the PDSN shall use KEY\_IKE as the transform identifier. All  
3 implementations must support 3DES and RSA.  
4

5 For Phase 2 Quick Exchange, the PDSN shall minimally support the ESP\_3DES  
6 transform identifier within a Transform Payload for IPsec ESP Proposal Payload. It must  
7 also support both HMAC-MD5 and HMAC-SHA1 as transform identifiers within a  
8 Transform payload for IPsec AH Proposal Payload. Service provider HAs shall likewise  
9 support these two transforms. The PDSN may optionally support and propose other  
10 transforms. An HA shall select one of the transforms offered by the PDSN.  
11

## 12 **Key Exchange Payload**

13  
14 The PDSN and HA will exchange D-H (Diffie-Hellman) public values computed in the D-  
15 H group negotiated as part of a protection suite in the first message exchange of Phase  
16 1 for ISAKMP SA establishment. The PDSN shall specify Phase 1 authentication with  
17 certificates when the peer's (root CA or HA) is available. Otherwise, if a pre-shared key  
18 is available, the PDSN shall specify Phase 1 authenticated with a pre-shared key mode  
19 of operation.  
20

## 21 **Identification Payload**

22  
23  
24 For Phase 1 negotiation, the PDSN must set the Protocol-Id field to zero or UDP. The  
25 port number must be set to zero or 500. If the HA receives any other values for these  
26 two fields in the Identification Payload, IKE negotiation must be aborted.  
27

28 For IKE authentication using pre-shared keys the PDSN and HA shall minimally support  
29 ID\_KEY\_ID in the ID Type field. For IKE authentication using Revised Public Key  
30 Encryption with RSA using X.509 certificates, the PDSN and HA shall minimally support  
31 ID\_DER\_ASN1\_DN in the ID Type field.  
32

33 For Phase 2 (Quick Mode), both the PDSN and HA shall include the client identifiers in  
34 the form of optional Client Identification Payloads as specified in IKE (i.e., IDci and IDcr).  
35 Two separate Quick Mode negotiations must be performed to establish two different  
36 types of IPsec security associations between the PDSN and HA to protect mobile IP  
37 control messages and tunneled user data.  
38

39 For IPsec security for Mobile IP control packets, the PDSN and HA shall exchange IDci  
40 and IDcr. The protocol field shall be set to UDP and port number to 434 for both IDci and  
41 IDcr.  
42

43 IDci: Protocol field = UDP, Port = 434, Idtype = ID\_KEY\_ID, Identification\_data =  
44 PDSN\_IPV4\_ADDR

45 IDcr: Protocol field = UDP, Port = 434, Idtype = ID\_KEY\_ID, Identification\_data =  
46 HA\_IPV4\_ADDR  
47

48 For IPsec on the user's tunneled data, the PDSN and the HA shall exchange client  
49 identification using a tunnel protocol type that matches the encapsulation type requested  
50 by the mobile station's RRQ. Examples of IDci and IDcr values when IP-IP tunnel is  
51 used are:  
52

53 IDci: Protocol field = IP-IP, Idtype = ID\_KEY\_ID, Identification\_data =  
54 PDSN\_IPV4\_ADDR

55 IDcr: Protocol field = IP-IP, Idtype = ID\_KEY\_ID, Identification\_data = HA\_IPV4\_ADDR  
56

1 **Certificate Payload**

2

3

The Certificate Payload shall carry X.509 version three certificates.

4

5 **Signature Payload**

6

7

The PDSN and HA shall not include this payload.

8

9

**Notification Payload**

10

11

The Notification Payload carries error messages and reason codes regarding failure for a peer to be able to establish a security association. The PDSN and HA handling of a failed security association establishment is specified in the main body of the Specification.

12

13

14

15

16

The PDSN and HA shall use the "SA Lifetime Notify" code as a trigger to refresh the indicated security association.

17

18

19 **Delete Payload**

20

21

The PDSN shall send a delete payload upon a SA refresh or upon request from a service provider administrator.

22

23

## 1 **Annex B: Certificates**

2 PDSNs and HAs shall use X.509 Version 3 certificates in conformance with RFC 2459. Each  
3 PDSN and HA in a service provider network may have a unique certificate which will be  
4 configured into the PDSN and HA. The method of configuration of certificates is outside the  
5 scope of this specification.

6  
7 Note: This Annex only applies to FA COA. Security between a collocated COA mobile station  
8 and the HA is outside the scope of this specification.

9  
10 Each service provider may be a Certificate Authority for itself and its client private networks and  
11 partner ISPs for PDSNs and for HAs that may be accessed by PDSNs. All PDSNs and HAs shall  
12 be configured with all service provider CA certificates. There should be one CA root certificate  
13 from each service provider.

### 14 **Certificates for PDSNs and HAs**

15  
16  
17 The Distinguished Name contained in the Issuer field is of form:

18  
19 `cdma2000.service-provider-name`

20  
21 The PDSN or HA determines the issuing service-provider (i.e., the CA) from the service-  
22 provider-*name* attribute of the Issuer's Distinguished Name. The PDSN and HA then use the  
23 service-provider-*name* attribute to locally access the CA's public key.

24  
25 The PDSN and HA shall use the SHA-1 as a hash function and either the RSA or DSA signing  
26 algorithm, as specified in RFC 2459 to verify a certificate. The private network or ISP shall  
27 provide the public key and Distinguished Name of the certificate.

28  
29 The Distinguished Name contained in the Subject field is of form:

30  
31 `cdma2000. service-provider-name.PDSN.service-provider-identifier`  
32 `cdma2000. service-provider-name.HA.service-provider-identifier`

33  
34 Certificates in the PDSN and HA will not use the Unique-Identifier field.

35  
36 Certificate extensions for PDSN and HA certificates shall not be supported.

37  
38 The method of providing PDSNs and HAs signed certificates to PDSNs and HAs is outside the  
39 scope of this specification.

### 40 **CA Certificates**

41  
42  
43 Service-providerCA certificates shall be configured into all PDSNs and HAs. A service-  
44 providerCA contains the public key that the PDSN or HA shall use to verify the signature of a  
45 certificate received in a Phase 1 ISAKMP exchange.

46  
47 A CA certificate shall conform to the X.509 V3 certificates in RFC 2459. Since the service-  
48 providerCA distributes its own certificate, the Authority Key Identifier and Subject Key Identifier  
49 extensions shall not be included in the certificate.

50  
51 The method by which service-providers exchange their CA certificates, as well as of providing  
52 certificates into PDSNs and HAs, is outside the scope of this specification.

53

1 **Certificate Revocation List (CRL)**

2

3 CRLs shall be used to store the identities of certificates that have been compromised or are  
4 otherwise invalid. CRLs shall conform to X.509 v2 as specified in RFC 2459. A future version of  
5 this specification will make use of the Online Certificate Status Protocol.

6

7 Service-providers shall exchange revoked certificate information (e.g., serial number). The  
8 frequency of the exchange is outside the scope of this specification.

9

10 Possession of a certificate does not imply service since the RADIUS and Mobile IP functions still  
11 control the user obtaining service, as well as the HA allowing access to the PDSN.

12

13 The CA certificate shall indicate the service provider CA as Issuer of the CRL. The DN of the  
14 Issuer shall be of form:

15

16 `cdma2000.service-provider-name`

17

18 CRLs exchanged between service providers shall use the SHA-1 as a hash function and either  
19 the RSA and DSA signing algorithm as specified in RFC 2459.

20

21 CRL extensions shall not be supported.

22

23 The method of exchanging CRLs between service providers, or to conveying certificates client  
24 private network or partnering ISP, as well providing this information into PDSNs and HAs, is  
25 outside the scope of this specification.

26

1 **Annex C: RADIUS Attributes**

2 This is the general Vendor Specific Format for all 3GPP2 RADIUS attributes. The type and  
 3 vendor ID are the same for every attribute. The vendor type, vendor length, and value are  
 4 specified below.  
 5

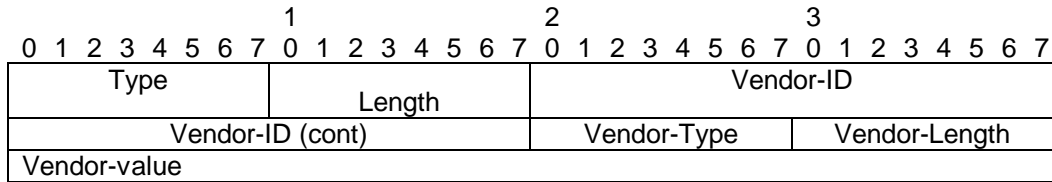

6  
 7 Type = cdma specific  
 8 Length >= 9  
 9

10 **Figure 8: 3GPP2 RADIUS Attribute Format**

11  
 12 **Type:** 26

13  
 14 **Length:** greater than 9

15  
 16 **3GPP2 Vendor ID:** 5535

17  
 18 **IKE Pre-shared Secret Request:** Indicates whether the PDSN needs a pre-shared secret for  
 19 Phase 1 IKE negotiation with the HA. This optionally appears in an Access-Request.  
 20

- 21 Vendor-Type = 1  
 22 Vendor-Length = 6  
 23 Vendor-Value =  
 24 1 - The PDSN requests a pre-shared secret for IKE  
 25 2 - The PDSN does not request a pre-shared secret for IKE  
 26

27 **Security level:** Indicates the type security that the home network mandates on the visited  
 28 network; this attribute optionally appears in the Access-Accept.  
 29

- 30 Vendor-Type = 2  
 31 Vendor-Length = 6  
 32 Vendor-Value =  
 33 1 - IPsec for registration messages  
 34 2 - IPsec for tunnels  
 35 3 - IPsec for tunnels and registration messages  
 36 4 - No IPsec security  
 37

38 **Pre-shared secret:** A pre-shared secret for IKE that optionally appears in an Access-Accept.  
 39

- 40 Vendor-Type = 3  
 41 Vendor-Length = 18  
 42 Vendor-Value = binary value of the pre-shared key  
 43

44 **Reverse Tunnel Specification:** Indicates the style of reverse tunneling that is required, and  
 45 optionally appears in an Access-Accept.  
 46

- 47 Vendor-Type = 4

1 Vendor-Length = 6  
2 Vendor-Value =  
3 0 - Reverse tunneling is not required  
4 1 - Reverse tunneling is required  
5

6 **Differentiated Services Class Option Attribute:** The Home RADIUS server authorizes  
7 differentiated service via the Differentiated Services Class Options Attribute, and optionally  
8 appears in an Access-Accept.  
9

10 Vendor-Type = 5  
11 Vendor-Length = 6  
12 Vendor-Value  
13 0 - Best Effort  
14 10 - AF11  
15 12 - AF12  
16 14 - AF13  
17 18 - AF21  
18 20 - AF22  
19 22 - AF23  
20 26 - AF31  
21 28 - AF32  
22 30 - AF33  
23 34 - AF41  
24 36 - AF42  
25 38 - AF43  
26 46 - EF  
27

28 The above values are taken from RFC 2597 and RFC 2598. There is no intention to convey the  
29 actual traffic specification parameters of the differentiated-services service.  
30

31 **Home Agent Attribute:** The address of the Home Agent that appears in an Access-Request and  
32 accounting messages.  
33

34 Vendor-Type = 7  
35 Vendor-Length = 6  
36 Vendor-Value = 4 octet IP address.  
37  
38

1 **Event Time Stamp:** Contains the start or end of the accounting session.

2

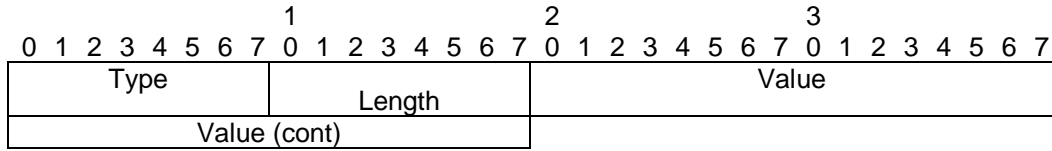

3

4

5

6

7

8

9

10 **Accounting Container:** Contains embedded 3GPP2 accounting attributes.

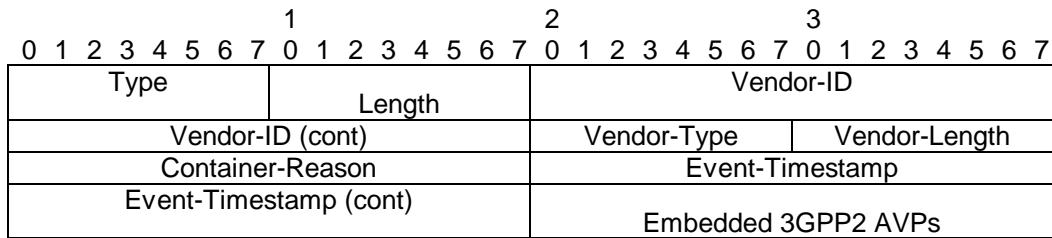

11

12

13

14

15

16

17

18

19

20

21

22

23

24

25

26

27

28

29

30

31

32

33

34

35

36

37

38

39

40

**KeyID Attribute:** Contains the KeyID parameter used during IKE exchange between the PDSN and the HA. This parameter is returned by the Home RADIUS server to the PDSN in Access-Accept.

Vendor-Type = 8  
Vendor-Length = 22  
Vendor-Value =

A number formed from the concatenation of the Home RADIUS IP Address, and the FA IP address, and a 32-bit timestamp, where each address is encoded using eight hexadecimal ASCII characters. The timestamp contains the number of seconds since January 1, 1970 00:00 UTC.

**'S' Attribute:** Contains the 'S' secret parameter used to make Pre-shared secret. This parameter is returned by the Home RADIUS to the HA in Access-Accept.

Vendor-Type = 11  
Vendor-Length = 3 or greater  
Vendor-Value = binary value of the secret.

1 **'S' lifetime Attribute:** Contains the lifetime of 'S' secret parameter used to make Pre-shared  
2 secret. This parameter is returned by the Home RADIUS to the HA in Access-Accept.

3 Vendor-Type = 12

4 Vendor-Length = 6

5 Vendor-Value = Number of seconds since January 1, 1970 00:00 UTC.

6

7 **'S' Request Attribute:** Indicates whether the HA requests a shared secret "S". This appears in  
8 an Access-Request to the Home RADIUS server:

9 Vendor-Type = 13

10 Vendor-Length = 6

11 Vendor-Value =

12 0. The HA does not request a 'S' secret for IKE

13 1. The HA requests a 'S' secret for IKE

14

1 **Annex D: Interim RADIUS Accounting**

2 An Interim Accounting record (with Acct-Status-Type = Interim-Update (3)) shall contain all of the  
3 attributes found in an Accounting Stop message with the exception of the Acct-Term-Cause  
4 attribute. The values of the attributes in the Interim Accounting record shall be cumulative since  
5 the Accounting-Request Start record.

6  
7 Since the accounting information is cumulative, the PDSN should ensure that only a single  
8 generation of an interim Accounting message for a given user and IP address is present in  
9 retransmission queues at any given time.

10  
11 The PDSN may add a random delay between Interim Accounting messages for separate  
12 sessions. This will ensure that a cycle where all messages are sent at once is prevented.  
13