

3GPP2 C.S0074-A

Version 1.0

Date: 25 January 2010



3RD GENERATION  
PARTNERSHIP  
PROJECT 2  
"3GPP2"

---

## ***UICC-Terminal interface - Physical and Logical Characteristics for cdma2000 Spread Spectrum Systems***

**© 2010 3GPP2**

3GPP2 and its Organizational Partners claim copyright in this document and individual Organizational Partners may copyright and issue documents or standards publications in individual Organizational Partner's name based on this document. Requests for reproduction of this document should be directed to the 3GPP2 Secretariat at [secretariat@3gpp2.org](mailto:secretariat@3gpp2.org). Requests to reproduce individual Organizational Partner's documents should be directed to that Organizational Partner. See [www.3gpp2.org](http://www.3gpp2.org) for more information.

## Revision History

<u>Revision</u>	<u>Description</u>	<u>Date</u>
C.S0074-0	Release 0	December 2005
C.S0074-0	v1.0 Replacement Text	February 2009
C.S0074-A	Revision A	January 2010

Note: This is a replacement version. Corrections have been made to the title page.

## CONTENTS

1	SCOPE.....	1
2	DEFINITIONS, SYMBOLS, ABBREVIATIONS AND CODING CONVENTIONS.....	1
3	UICC-TERMINAL INTERFACE; PHYSICAL AND LOGICAL CHARACTERISTICS.....	1
4	APPLICATION INDEPENDENT FILES .....	1
4.1	DF <sub>MMSS</sub> (MULTIMODE SYSTEM SELECTION) .....	1
4.1.1	EF <sub>MLPL</sub> (MMSS LOCATION ASSOCIATED PRIORITY LIST).....	2
4.1.2	EF <sub>MSPL</sub> (MMSS SYSTEM PRIORITY LIST).....	3
4.1.3	EF <sub>MMSSMODE</sub> (MMSS MODE SETTINGS) .....	4
ANNEX A	(NORMATIVE) LIST OF SFI VALUES AND FILES STRUCTURE OF DFMMSS .....	5
ANNEX B	(INFORMATIVE) SUGGESTED CONTENTS OF APPLICATION INDEPENDENT EFS AT PRE-PERSONALIZATION .....	6

**TABLES**

TABLE A-1 SFI VALUES FOR EFs UNDER DFMMSS .....5  
TABLE B-1 SUMMARY OF APPLICATION INDEPENDENT EF .....6

**FOREWORD**

1  
2  
3  
4  
5  
6  
7  
8  
9  
10  
11  
12  
13  
14  
15

(This foreword is not part of this specification)

This document was prepared by 3GPP2 TSG-C WG1.

The present document specifies the interface between the UICC and the Terminal for cdma2000<sup>®1</sup> network operation.

The present document specifies:

- the requirements for the physical characteristics of the UICC;
- the electrical interface between the UICC and the Terminal;
- the initial communication establishment and the transport protocols;
- the model which serves as a basis for the logical structure of the UICC;
- the communication commands and the procedures;
- the application-independent files and protocols.

The administrative procedures and initial card management are not part of the present document.

---

<sup>1</sup> cdma2000<sup>®</sup> is the trademark for the technical nomenclature for certain specifications and standards of the Organizational Partners (OPs) of 3GPP2. Geographically (and as of the date of publication), cdma2000<sup>®</sup> is a registered trademark of the Telecommunications Industry Association (TIA-USA) in the United States.

1 **NOTES**

- 2 1. The following verbal forms are used: "Shall" and "shall not" identify requirements  
3 to be followed strictly to conform to the standard and from which no deviation is  
4 permitted. "Should" and "should not" indicate that one of several possibilities is  
5 recommended as particularly suitable, without mentioning or excluding others;  
6 that a certain course of action is preferred but not necessarily required; or that  
7 (in the negative form) a certain possibility or course of action is discouraged but  
8 not prohibited. "May" and "need not" indicate a course of action permissible  
9 within the limits of the standard. "Can" and "cannot" are used for statements of  
10 possibility and capability, whether material, physical, or causal.
- 11 2. Footnotes appear at various points in this specification to elaborate and to  
12 further clarify items discussed in the body of the specification.
- 13 3. Unless indicated otherwise, this document presents numbers in decimal form.
- 14 Binary numbers are distinguished in the text by the use of single quotation  
15 marks. In some tables, binary values may appear without single quotation marks  
16 if table notation clearly specifies that values are binary. The character 'x' is used  
17 to represent a bit of unspecified value. For example 'xxx00010' represents any 8-  
18 bit binary value such that the least significant five bits equal '00010'.
- 19 Hexadecimal numbers (base 16) are distinguished in the text by use of the form  
20 0xhh where hh represents a string of hexadecimal digits. For example, 0x2fa1  
21 represents a number whose binary value is '0010111110100001' and whose  
22 decimal value is 12193. Note that the exact number of bits in the binary  
23 representation of a hexadecimal number strictly depends upon the  
24 implementation requirements for the variable being represented.
- 25 4. "Base station" refers to the functions performed on the fixed network, which are  
26 typically distributed among a cell, a sector of a cell, and a mobile communications  
27 switching center.
- 28

## REFERENCES

The following standards are referenced in this text. At the time of publication, the editions indicated were valid. All standards are subject to revision, and parties to agreements based upon this document are encouraged to investigate the possibility of applying the most recent editions of the standards indicated below. ANSI and TIA maintain registers of currently valid national standards published by them.

### ***Normative References:***

1. ETSI TS 102 221 v8.3.0, *Smart Cards; UICC-Terminal interface; Physical and logical characteristics*, August 2009.
2. 3GPP TS 31.101 v9.0.0, *UICC-Terminal interface; Physical and logical characteristics*, Release December 2009.
3. 3GPP2 C.S0016-D v1.0, *Over-The-Air Service Provisioning of Mobile Station in Spread Spectrum Systems*, January 2010.
4. 3GPP2 C.S0079-0, *Remote APDU Structure for CDMA Card Application Toolkit (CCAT) Applications*, November 2006.
5. 3GPP2 C.S0065-B v1.0, *cdma2000 Application on UICC for Spread Spectrum Systems*, January 2010.

### ***Informative References:***

6. ETSI TS 102 225 v8.2.0, *Smart Cards; Secured packet structure for UICC based applications*, April 2009.
7. ETSI TS 102 226 v9.1.0, *Smart Cards; Remote APDU structure for UICC based applications*, October 2009.

1

## 1 1 SCOPE

2 The present document defines a generic Terminal/Integrated Circuit Card (ICC)  
3 interface for cdma2000 applications. The present document is based on [1], which  
4 defines a generic platform for any IC card application. Requirements that are common  
5 to all cdma2000 smart card based applications are also listed in this specification.

6 The aim of the present document is to ensure interoperability between an ICC and a  
7 terminal independently of the respective manufacturer, card issuer or operator. The  
8 present document does not define any aspects related to the administrative  
9 management phase of the ICC. Any internal technical realization of either the ICC or  
10 the terminal is only specified where these are reflected over the interface.

11 Application specific details for applications residing on an ICC are specified in the  
12 respective application specific documents.

13 References to this document from cdma2000 application specifications related to  
14 functionalities that are not described in the present document are to be considered as  
15 direct references to [1].

## 16 2 DEFINITIONS, SYMBOLS, ABBREVIATIONS AND CODING CONVENTIONS

17 All definitions, symbols, abbreviations applicable to the UICC-terminal interface in  
18 CDMA Spread Spectrum Systems are specified in [1].

## 19 3 UICC-TERMINAL INTERFACE; PHYSICAL AND LOGICAL CHARACTERISTICS

20 The UICC-Terminal interface in the context of CDMA Spread Spectrum systems shall  
21 comply with all requirements specified in [2]. "3GPP" shall be interpreted as "3GPP2" in  
22 the context of CDMA Spread Spectrum Systems.

## 23 4 APPLICATION INDEPENDENT FILES

### 24 4.1 DF<sub>MMSS</sub> (Multimode System Selection)

25 If Multimode System Selection (MMSS) is supported by UICC, DF<sub>MMSS</sub> '5F3C' shall be  
26 present under DF<sub>TELECOM</sub>. If an ME supports MMSS, it shall select DF<sub>MMSS</sub> and read the  
27 parameters and settings from the EFs under DF<sub>MMSS</sub>. The parameters and settings  
28 which are present in the EFs under DF<sub>MMSS</sub> shall take precedence over the ones  
29 present in the terminal it is inserted to.

30 The following EFs can use various provisioning mechanisms such as: the standard  
31 Remote File Management procedures defined for UICC as defined in [4], for updating  
32 and modifications, and the commands, e.g., OTASP/OTAPA related commands defined  
33 in [5].

34

1 4.1.1 EF<sub>MLPL</sub> (MMSS Location Associated Priority List)

2 This EF stores the Multimode System Selection Location Associated Priority List as  
 3 defined in section 3.5.13.3 of [3].

Identifier: '4F20'		Structure: transparent		Optional	
SFI: '01'					
File size: X bytes			Update activity: Low		
Access Conditions:					
READ		PIN			
UPDATE		ADM			
DEACTIVATE		ADM			
ACTIVATE		ADM			
Bytes	Description			M/O	Length
1 to X	MLPL as defined in [3]			M	X bytes

4 MLPL: This is the MMSS Location Associated Priority List

5 Coding: See 4.5.11.2 of [3]

6 Unused bytes shall be set to 'FF'.

7 This EF is stored using the convention from [3], i.e. fields are placed into octets starting  
 8 with the MSB of the first field into bit 8 of the first octet, followed by the remaining  
 9 fields placed in sequence into the remaining bits allocated for those fields. A multi-  
 10 octet integer is stored by placing the octet with the MSB into the lowest numbered  
 11 available octet allocated for that integer in the EF.

12

1 4.1.2 EF<sub>MSPL</sub> (MMSS System Priority List)

2 This EF Stores the Multimode System Selection System Priority List as defined in  
 3 section 3.5.13.4 of [3].

Identifier: '4F21'		Structure: transparent		Optional	
SFI: '02'					
File size: X bytes			Update activity: Low		
Access Conditions:					
READ		PIN			
UPDATE		ADM			
INVALIDATE		ADM			
REHABILITATE		ADM			
Bytes	Description			M/O	Length
1 to X	MSPL as defined in [3]			M	X bytes

4 MSPL: This is the MMSS System Priority List

5 Coding: See 4.5.11.3 of [3]

6 Unused bytes shall be set to 'FF'

7 This EF is stored using the convention from [3], i.e. fields are placed into octets starting  
 8 with the MSB of the first field into bit 8 of the first octet, followed by the remaining  
 9 fields placed in sequence into the remaining bits allocated for those fields. A multi-  
 10 octet integer is stored by placing the octet with the MSB into the lowest numbered  
 11 available octet allocated for that integer in the EF.

12

1 4.1.3 EF<sub>MMSSMODE</sub> (MMSS Mode Settings)

2 This EF stores the Multimode System Selection Mode Settings as defined in section  
 3 3.5.13.2 of [3].

Identifier: '4F22'		Structure: transparent		Optional	
SFI: '03'					
File size: 1 byte			Update activity: Low		
Access Conditions:					
READ		PIN			
UPDATE		ADM			
DEACTIVATE		ADM			
ACTIVATE		ADM			
Bytes	Description		M/O	Length	
1	MMSS Mode Settings as defined in [3]		M	1 byte	

4 This EF is stored using the convention from [3], i.e. fields are placed into octets starting  
 5 with the MSB of the first field into bit 8 of the first octet, followed by the remaining  
 6 fields placed in sequence into the remaining bits allocated for those fields. A multi-  
 7 octet integer is stored by placing the octet with the MSB into the lowest numbered  
 8 available octet allocated for that integer in the EF.

9

1

1 ANNEX A (NORMATIVE) LIST OF SFI VALUES AND FILES STRUCTURE OF  
 2 DFMMSS

3 Table A-1 SFI values for EFs under DFMMSS

File Identification	SFI	Description
'4F20'	'01'	MMSS Location Associated Priority List
'4F21'	'02'	MMSS System Priority List
'4F22'	'03'	MMSS Mode Settings

4

see TS  
 102.221  
 [1]

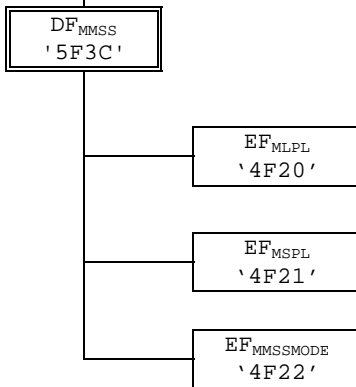

5

6

1

1 **ANNEX B (INFORMATIVE) SUGGESTED CONTENTS OF APPLICATION**  
 2 **INDEPENDENT EFS AT PRE-PERSONALIZATION**

3 Table B-1 is a general outline of the files defined in this specification.

- 4 1. All values are sized in bytes unless otherwise noted.  
 5 2. Default Values are specified when available and are intended to be guidelines  
 6 only. In some cases, operators must specify explicit parameter values as no  
 7 logical default exists. In the case where the parameter values are necessary,  
 8 valid values and/or ranges are listed.  
 9 3. Default and Parameter values are for general quick reference only and not  
 10 intended to specify details. Refer to the corresponding file for details.  
 11 4. Default Values and Parameter Values are specified in Hexadecimal, unless  
 12 otherwise noted.

13 If EFs have an unassigned value, it may not be clear from the main text what this  
 14 value should be. This annex suggests values in these cases.

15 **Table B-1 Summary of Application Independent EF**

File Name	File ID	File Type	Access Read	Access Update	Access Invalidate - Rehabilitate	Size in Bytes	Mandatory Or Optional	Default Values (D) and/or Parameter Values (P) in Bytes
<b>Multimode System Selection Parameters</b>								
EF <sub>MLPL</sub>	4F20	TR	PIN	ADM	ADM-ADM	Variable	O	Specified by Operator
EF <sub>MSPL</sub>	4F21	TR	PIN	ADM	ADM-ADM	Variable	O	Specified by Operator
EF <sub>MMSSMODE</sub>	4F22	TR	PIN	ADM	ADM-ADM	Variable	O	Specified by Operator

16