

3GPP2 C.S0061-0

Version 1.0

Version Date: 22 June 2005



3RD GENERATION  
PARTNERSHIP  
PROJECT 2  
"3GPP2"

# Signaling Conformance Test Specification for Short Message Service

## ***COPYRIGHT NOTICE***

*3GPP2 and its Organizational Partners claim copyright in this document and individual Organizational Partners may copyright and issue documents or standards publications in individual Organizational Partner's name based on this document. Requests for reproduction of this document should be directed to the 3GPP2 Secretariat at [secretariat@3gpp2.org](mailto:secretariat@3gpp2.org). Requests to reproduce individual Organizational Partner's documents should be directed to that Organizational Partner. See [www.3gpp2.org](http://www.3gpp2.org) for more information.*



# CONTENTS

		1
		2
		3
		4
		5
1	Introduction.....	1-1
	1.1 General Description .....	1-1
	1.2 References .....	1-2
	1.2.1 Normative and Informative References .....	1-2
	1.3 Definitions, Symbols and Abbreviations.....	1-3
	1.3.1 Supplementary Terms and Definitions .....	1-3
	1.4 Test Setup and Channel conditions .....	1-6
	1.4.1 Test Setup .....	1-6
	1.4.2 Channel Conditions .....	1-6
2	SMS Relay Layer Test.....	2-1
	2.1 Common Channel SMS Delivery – Mobile Terminated .....	2-2
	2.1.1 Mobile Station Test .....	2-2
	2.1.2 Base Station Test.....	2-3
	2.2 Traffic Channel SMS Delivery while in the Conversation Substate – Mobile Terminated.....	2-4
	2.2.1 Mobile Station Test .....	2-4
	2.2.2 Base Station Test.....	2-5
	2.3 Delivery of Maximum Length Message.....	2-6
	2.3.1 Mobile Station Test .....	2-6
	2.3.2 Base Station Test.....	2-7
	2.4 Common Channel SMS Delivery – Mobile Originated.....	2-8
	2.4.1 Mobile Station Test .....	2-8
	2.4.2 Base Station Test.....	2-9
	2.5 Traffic Channel SMS Delivery – Mobile Originated .....	2-10
	2.5.1 Mobile Station Test .....	2-10
	2.5.2 Base Station Test.....	2-11
	2.6 Traffic Channel SMS Delivery while in the Conversation Substate – Mobile Originated... 2-12	2-12
	2.6.1 Mobile Station Test .....	2-12
	2.6.2 Base Station Test.....	2-13
3	SMS Transport Layer Test.....	3-1
	3.1 SMS Acknowledgement Message.....	3-2
	3.1.1 Mobile Station Test .....	3-2
	3.1.2 Base Station Test.....	3-3
	3.2 SMS Delivery Error - Mobile Station Short Message Buffer Full .....	3-5
	3.2.1 Mobile Station Test .....	3-5
	3.2.2 Base Station Test.....	3-6
	3.3 SMS Delivery Error - Unknown Destination Address .....	3-7
	3.3.1 Mobile Station Test .....	3-7
	3.3.2 Base Station Test.....	3-8
	3.4 SMS Delivery Error - Mobile Station Originated SMS Disabled .....	3-10
	3.4.1 Mobile Station Test .....	3-10
	3.4.2 Base Station Test.....	3-11

1  
2  
3  
4  
5  
6  
7  
8  
9  
10  
11  
12  
13  
14  
15  
16  
17  
18  
19  
20  
21  
22  
23  
24  
25  
26  
27  
28  
29  
30  
31  
32  
33  
34  
35  
36  
37  
38  
39  
40  
41  
42  
43  
44  
45  
46  
47  
48  
49  
50  
51  
52  
53  
54  
55  
56  
57  
58  
59  
60

- 3.5 SMS Delivery Error - SMS Not Supported by Base Station..... 3-13
  - 3.5.1 Mobile Station Test ..... 3-13
  - 3.5.2 Base Station Test..... 3-14
- 3.6 Authentication Upon SMS Originations..... 3-16
  - 3.6.1 Mobile Station Test ..... 3-16
  - 3.6.2 Base Station Test..... 3-17
- 3.7 Broadcast SMS Delivery ..... 3-18
  - 3.7.1 Mobile Station Test ..... 3-18
  - 3.7.2 Base Station Test..... 3-20
- 4 SMS Teleservice Layer Test ..... 4-1
  - 4.1 Voice Mail Notification ..... 4-3
    - 4.1.1 Mobile Station Test ..... 4-3
    - 4.1.2 Base Station Test..... 4-4
  - 4.2 Setting of Message Identifier Field..... 4-5
    - 4.2.1 Mobile Station Test ..... 4-5
    - 4.2.2 Base Station Test..... 4-6
  - 4.3 Unique Message Identification – Mobile Terminated..... 4-7
    - 4.3.1 Mobile Station Test ..... 4-7
    - 4.3.2 Base Station Test..... 4-8
  - 4.4 User Acknowledgement Request ..... 4-9
    - 4.4.1 Mobile Station Test ..... 4-9
    - 4.4.2 Base Station Test..... 4-10
  - 4.5 SMS Delivery Acknowledgement Request ..... 4-11
    - 4.5.1 Mobile Station Test ..... 4-11
    - 4.5.2 Base Station Test..... 4-11
  - 4.6 Read Acknowledgement Request ..... 4-13
    - 4.6.1 Mobile Station Test ..... 4-13
    - 4.6.2 Base Station Test..... 4-14
  - 4.7 Mobile Station Terminated Enhanced Messaging Services [EMS] Tests:..... 4-15
    - 4.7.1 Concatenated Short Message EMS Message Delivery ..... 4-15
    - 4.7.2 Delivery of Predefined EMS Information Elements..... 4-17
    - 4.7.3 Delivery of User Defined EMS Information Elements..... 4-21
    - 4.7.4 Delivery of Formatted Text ..... 4-27
  - 4.8 Mobile Station Originated Enhanced Messaging Services [EMS] Tests:..... 4-29
    - 4.8.1 Concatenated Short Message EMS Message Delivery ..... 4-29
    - 4.8.2 Delivery of Predefined EMS Information Elements..... 4-31
    - 4.8.3 Delivery of User Defined EMS Information Elements..... 4-35
    - 4.8.4 Delivery of Formatted Text ..... 4-41

# LIST OF FIGURES

Figure 1 Test Setup..... 1-6  
Figure 2 Functional Setup for Broadcast SMS Tests..... 3-18

1  
2  
3  
4  
5  
6  
7  
8  
9  
10  
11  
12  
13  
14  
15  
16  
17  
18  
19  
20  
21  
22  
23  
24  
25  
26  
27  
28  
29  
30  
31  
32  
33  
34  
35  
36  
37  
38  
39  
40  
41  
42  
43  
44  
45  
46  
47  
48  
49  
50  
51  
52  
53  
54  
55  
56  
57  
58  
59  
60

1  
2  
3  
4  
5  
6  
7  
8  
9  
10  
11  
12  
13  
14  
15  
16  
17  
18  
19  
20  
21  
22  
23  
24  
25  
26  
27  
28  
29  
30  
31  
32  
33  
34  
35  
36  
37  
38  
39  
40  
41  
42  
43  
44  
45  
46  
47  
48  
49  
50  
51  
52  
53  
54  
55  
56  
57  
58  
59  
60

No text.

# LIST OF TABLES

*Table 1.* SMS Relay Layer Tests ..... 2-1

*Table 2.* SMS Transport Layer Tests ..... 3-1

*Table 3.* Broadcast Messages and Priority ..... 3-19

*Table 4.* SMS Teleservice Layer Tests ..... 4-2

1  
2  
3  
4  
5  
6  
7  
8  
9  
10  
11  
12  
13  
14  
15  
16  
17  
18  
19  
20  
21  
22  
23  
24  
25  
26  
27  
28  
29  
30  
31  
32  
33  
34  
35  
36  
37  
38  
39  
40  
41  
42  
43  
44  
45  
46  
47  
48  
49  
50  
51  
52  
53  
54  
55  
56  
57  
58  
59  
60

1  
2  
3  
4  
5  
6  
7  
8  
9  
10  
11  
12  
13  
14  
15  
16  
17  
18  
19  
20  
21  
22  
23  
24  
25  
26  
27  
28  
29  
30  
31  
32  
33  
34  
35  
36  
37  
38  
39  
40  
41  
42  
43  
44  
45  
46  
47  
48  
49  
50  
51  
52  
53  
54  
55  
56  
57  
58  
59  
60

No text.

# FOREWORD

(This foreword is not part of this Standard.)

This Specification was prepared by Technical Specification Group C of the Third Generation Partnership Project 2 (3GPP2). This Specification is the first revision of the document and tests the signaling conformance requirements of C.S0015-B (SMS for Wideband Spread Spectrum Systems). Other signaling conformance specifications such as C.S0043-0 (Signaling Conformance Test Specification for cdma2000<sup>®</sup> Spread Spectrum System) do not cover SMS signaling conformance tests.

## SCOPE

This specification defines SMS signaling conformance tests for CDMA base stations and mobile stations. In this document, 'mobile station' refers to a subscriber terminal, handset, PDA, wireless local loop unit, or any other subscriber terminal that communicates with the base station at the air interface. 'Base station' refers to the composite functionality of the base station and connected network elements or emulators.

*"cdma2000<sup>®</sup> is the trademark for the technical nomenclature for certain specifications and standards of the Organizational Partners (OPs) of 3GPP2. Geographically (and as of the date of publication), cdma2000<sup>®</sup> is a registered trademark of the Telecommunications Industry Association (TIA-USA) in the United States."*

1  
2  
3  
4  
5  
6  
7  
8  
9  
10  
11  
12  
13  
14  
15  
16  
17  
18  
19  
20  
21  
22  
23  
24  
25  
26  
27  
28  
29  
30  
31  
32  
33  
34  
35  
36  
37  
38  
39  
40  
41  
42  
43  
44  
45  
46  
47  
48  
49  
50  
51  
52  
53  
54  
55  
56  
57  
58  
59  
60

1  
2  
3  
4  
5  
6  
7  
8  
9  
10  
11  
12  
13  
14  
15  
16  
17  
18  
19  
20  
21  
22  
23  
24  
25  
26  
27  
28  
29  
30  
31  
32  
33  
34  
35  
36  
37  
38  
39  
40  
41  
42  
43  
44  
45  
46  
47  
48  
49  
50  
51  
52  
53  
54  
55  
56  
57  
58  
59  
60

No text.

# 1 Introduction

---

## 1.1 General Description

---

The objective of these tests is to demonstrate mobile station or base station compliance to over-the-air messaging and protocol requirements in the cdma2000 family of standards, with emphasis on reference [1], indicated in the Traceability sections of each test case. This standard does not address all possible test cases.

Execution Strategy: Separate signaling conformance tests are specified for mobile stations and base stations. Tests are typically performed using an emulator to interface with the unit under test, with a cabled connection for the RF interface. Any test should be executed only if unit under test supports corresponding feature.

1  
2  
3  
4  
5  
6  
7  
8  
9  
10  
11  
12  
13  
14  
15  
16  
17  
18  
19  
20  
21  
22  
23  
24  
25  
26  
27  
28  
29  
30  
31  
32  
33  
34  
35  
36  
37  
38  
39  
40  
41  
42  
43  
44  
45  
46  
47  
48  
49  
50  
51  
52  
53  
54  
55  
56  
57  
58  
59  
60

## 1.2 References

---

### 1.2.1 Normative and Informative References

---

The following standards are referenced in this text. At the time of publication, the editions indicated were valid. All standards are subject to revision, and parties to agreements based on this standard are encouraged to investigate the possibility of applying the most recent editions of the standards indicated below. ANSI and TIA maintain registers of currently valid national standards published by them.

#### Normative References:

- [1] 3GPP2 C.S0015-B (TIA-637-C), Short Message Service for Wideband Spread Spectrum Systems, 2004
- [2] 3GPP TS 23.040 *Technical realization of the Short Message Service (SMS)*
- [3] C.S0005-A (TIA/EIA/IS-2000.5-A) *Upper Layer (Layer 3) Signaling Standard for cdma2000 Spread Spectrum Systems*
- [4] N.S0005 (TIA/EIA-41-D), *Cellular Radiotelecommunications Intersystem Operations*

#### Informative References:

- [5] C.R1001-D v1.0 (TSB-58F) *Administration of Parameter Values for cdma2000 Spread Spectrum Standards*

## 1.3 Definitions, Symbols and Abbreviations

---

### 1.3.1 Supplementary Terms and Definitions

---

#### **AFI**

---

Authority and Format Identifier (AFI). The high order octet of the NSAP-Address.

#### **Base Station**

---

A fixed station that is used for communicating with mobile stations. Depending upon the context, the term base station may refer to a cell, a sector, an MSC, or another part of the wireless system. See also MSC.

#### **Bearer Service**

---

The portion of the SMS system responsible for delivery of messages between the message center and mobile user equipment. In this standard, the bearer service protocol is divided into a Transport Layer and a Relay Layer.

#### **Broadcast**

---

The bearer layer mechanism that is used to deliver SMS messages on the Paging Channel, Primary Broadcast Control Channel, or on the Forward Traffic Channel- to all available mobile stations.

#### **Broadcast Messaging Service**

---

A teleservice that allows an SMS message to be sent to all mobile stations.

#### **CATPT**

---

Card Application Toolkit Protocol Teleservice (CATPT) that is used for data download to the R-UIM via SMS.

#### **CMT**

---

Cellular Messaging Teleservice. See also Wireless Messaging Teleservice.

#### **CPT**

---

Cellular Paging Teleservice. See also Wireless Paging Teleservice.

#### **EMS**

---

Enhanced Messaging Service. This service is further described in [2].

#### **End Point**

---

An element of the SMS delivery system that can originate or terminate SMS messages.

1  
2  
3  
4  
5  
6  
7  
8  
9  
10  
11  
12  
13  
14  
15  
16  
17  
18  
19  
20  
21  
22  
23  
24  
25  
26  
27  
28  
29  
30  
31  
32  
33  
34  
35  
36  
37  
38  
39  
40  
41  
42  
43  
44  
45  
46  
47  
48  
49  
50  
51  
52  
53  
54  
55  
56  
57  
58  
59  
60

**IWF**

---

An interworking function provides information conversion. A data service IWF provides functions needed for a mobile station to communicate with data terminal equipment connected to the network.

**MC**

---

SMS Message Center.

**Mobile Equipment (ME)**

---

An R-UIM capable mobile station without an R-UIM inserted.

**Mobile Switching Center (MSC)**

---

A configuration of equipment that provides wireless radio telephone service. Also called Mobile Telephone Switching Office (MTSO).

**Mobile-Originated**

---

Submitted to an SMS service provider by a mobile station.

**Mobile Station**

---

A station, fixed or mobile, which serves as the end user's wireless communication link with the base station. Mobile stations include portable units (e.g., hand-held mobile units) and units installed in vehicles.

**Mobile-Terminated**

---

Delivered to a mobile station by an SMS service provider.

**NSAP**

---

Network Service Access Point (NSAP). The NSAP is an abstraction of a point where the Network Layer service user and the Network Layer service provider meet. Each Network Entity may be accessed through one or more NSAPs by its users. Each NSAP has one or more NSAP-Addresses.

**Removable User Identity Module (R-UIM)**

---

See User Identity Module.

**Relay Layer**

---

The layer of the bearer service protocol responsible for the interface between the Transport Layer and the Link Layer used for message transmission.

**Relay Point.**

---

An element of the SMS delivery system that forwards SMS messages.

**SCPT**

---

Service Category Programming Teleservice (SCPT) that is used to add or remove Broadcast Service Categories in the mobile station profile.

---

## SMS

Short Message Service.

---

## Teleservice Layer

The protocol layer providing the end-to-end SMS application.

---

## TE

Terminal Equipment.

---

## Transport Layer

The layer of the bearer service protocol responsible for the end-to-end delivery of messages.

---

## User Identity Module (UIM)

The UIM contains subscription information such as the NAM and may contain subscription feature information. The UIM can be integrated into any mobile terminal or it may be removable.

---

## Universal Coordinated Time (UTC)

An internationally agreed-upon time scale maintained by the Bureau International de l'Heure (BIH) used as the time reference by nearly all commonly available time and frequency distribution systems (i.e., WWV, WWVH, LORAN-C, Transit, Omega, and GPS).

---

## VMN

Voice Mail Notification.

---

## WAP

Wireless Application Protocol.

---

## WEMT

Wireless Enhanced Messaging Teleservice (WEMT) that is used to carry Enhanced Messaging Service (EMS) over SMS.

---

## WMT

Wireless Messaging Teleservice. WMT is a point-to-point service only.

---

## WPT

Wireless Paging Teleservice. WPT is a point-to-point service only.

## 1.4 Test Setup and Channel conditions

---

### 1.4.1 Test Setup

---

Unless specified otherwise in a test case, the following conditions apply for all test cases in this document:

- ?? Transport Layer message shall enable the Bearer Reply Option.
- ?? Power-up registration shall be enabled by setting POWER\_UP\_REG = '1' in the *System Parameters Message* or the *ANSI-41 System Parameters Message*

Unless specified otherwise in a test case, setup shown in Figure 1 shall be used for all test cases in this document.

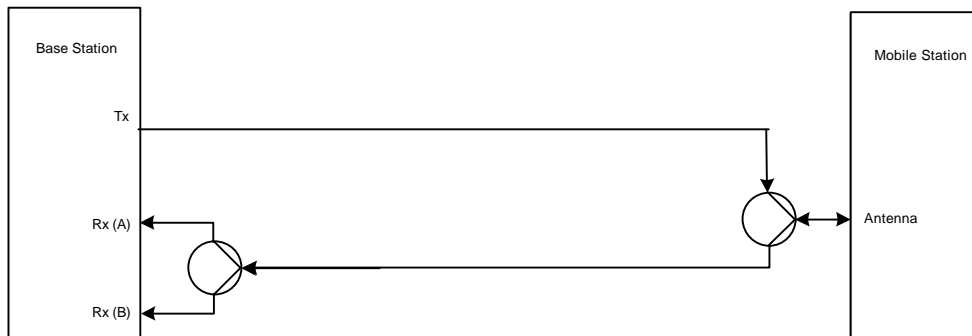

Figure 1 Test Setup

### 1.4.2 Channel Conditions

---

Unless specified otherwise in a test case, channel conditions for a test shall be set to have low FER.

No text.

- 1
- 2
- 3
- 4
- 5
- 6
- 7
- 8
- 9
- 10
- 11
- 12
- 13
- 14
- 15
- 16
- 17
- 18
- 19
- 20
- 21
- 22
- 23
- 24
- 25
- 26
- 27
- 28
- 29
- 30
- 31
- 32
- 33
- 34
- 35
- 36
- 37
- 38
- 39
- 40
- 41
- 42
- 43
- 44
- 45
- 46
- 47
- 48
- 49
- 50
- 51
- 52
- 53
- 54
- 55
- 56
- 57
- 58
- 59
- 60



## 2 SMS Relay Layer Test

Table 1 lists SMS Relay Layer tests:

Test No.	Title
2.1	Common Channel SMS Delivery – Mobile Terminated
2.2	Traffic Channel SMS Delivery – Mobile Terminated
2.3	Traffic Channel SMS Delivery while in the Conversation Substate – Mobile Terminated
2.4	Delivery of Maximum Length Message
2.5	Common Channel SMS Delivery – Mobile Originated
2.6	Traffic Channel SMS Delivery – Mobile Originated
2.7	Traffic Channel SMS Delivery while in the Conversation Substate – Mobile Originated

**Table 1. SMS Relay Layer Tests**

## 2.1 Common Channel SMS Delivery – Mobile Terminated

---

### 2.1.1 Mobile Station Test

---

#### 2.1.1.1 Definition

---

This test verifies that a short message can be sent to a mobile station in the *Mobile Station Idle State*.

#### 2.1.1.2 Traceability

---

(See [1]):

2.4.1.1.1.1: *Mobile SMS Message Termination*

2.4.2.1.1.2: *Mobile SMS Message Termination*

#### 2.1.1.3 Method of Measurement

---

- a. Clear all short messages stored in the mobile station.
- b. Delete all outstanding short messages in the network for the mobile station.
- c. Create a short message in the Message Center for the mobile station. Ensure that the short message length is less than the maximum allowed size on the f-csch so that it can be sent to the mobile station on the f-csch<sup>1</sup>.
- d. Power on the mobile station and wait until it is in the *Mobile Station Idle State*.
- e. Instruct the network to send the short message to the mobile station. Ensure that the base station sends a *Data Burst Message* to the mobile station with the following fields set as follows:

Field	Value
MSG_NUMBER	1 ('00000001')
BURST_TYPE	3 ('000011')
NUM_MSGS	1 ('00000001')
NUM_FIELDS	Greater than 0

- f. Upon receiving the *Data Burst Message* at the mobile station, verify the following:

---

<sup>1</sup> This is base station implementation dependent.

1. The mobile station alerts the user for the incoming short message and correctly displays the received short message, when selected.
2. The mobile station transmits an r-csch *Data Burst Message* to acknowledge the short message and indicating no error (i.e. contains a 'Cause Codes' parameter having ERROR\_CLASS = '00').

#### **2.1.1.4 Minimum Standard**

---

The mobile station shall comply with step f.

#### **2.1.2 Base Station Test**

---

None.

1  
2  
3  
4  
5  
6  
7  
8  
9  
10  
11  
12  
13  
14  
15  
16  
17  
18  
19  
20  
21  
22  
23  
24  
25  
26  
27  
28  
29  
30  
31  
32  
33  
34  
35  
36  
37  
38  
39  
40  
41  
42  
43  
44  
45  
46  
47  
48  
49  
50  
51  
52  
53  
54  
55  
56  
57  
58  
59  
60

## 2.2 Traffic Channel SMS Delivery while in the Conversation Substate – Mobile Terminated

---

### 2.2.1 Mobile Station Test

---

#### 2.2.1.1 Definition

---

This test verifies a short message can be sent to a mobile station when it is already in the *Conversation Substate*.

#### 2.2.1.2 Traceability

---

(See [1]):

2.4.1.1.2: Mobile SMS Message Termination

2.4.1.1.2.2: Mobile SMS Message Termination

2.4.2.1.2: Base Station Traffic Channel Procedures

2.4.2.1.2.4: Mobile Station Message Termination in the *Conversation Substate*

#### 2.2.1.3 Method of Measurement

---

- a. Clear all short messages store in the mobile station.
- b. Delete all outstanding short messages in the network for the mobile station.
- c. Set up a mobile station originated voice call.
- d. While the mobile station is in the *Conversation Substate*, create a short message in the Message Center for the mobile station and instruct the network to send the short message to the mobile station. Ensure that the base station sends a *Data Burst Message* on the f-dsch to the mobile station, with the following fields set as follows:

Field	Value
MSG_NUMBER	1 ('00000001')
BURST_TYPE	3 ('000011')
NUM_MSGS	1 ('00000001')
NUM_FIELDS	Greater than 0

- e. Upon receiving *Data Burst Message* at the mobile station, verify the following:
  1. The mobile station remains in *Conversation Substate*.

2. The mobile station should alert the user for the incoming short message and correctly display the received short message, when selected.
  3. The mobile station transmits a r-dsch *Data Burst Message* to acknowledge the short message and indicating no error (i.e. contains a Cause Codes parameter having ERROR\_CLASS = '00').
- f. Repeat step c-e with a packet data call.

#### **2.2.1.4 Minimum Standard**

---

The mobile station shall comply with step e.

#### **2.2.2 Base Station Test**

---

None.

## 2.3 Delivery of Maximum Length Message

---

### 2.3.1 Mobile Station Test

---

#### 2.3.1.1 Definition

---

This test verifies the SMS transport layer capability to send to a mobile station a short message of the maximum size. This test also verifies that if a short message length exceeds the maximum allowable length for f-csch transport, the short message is delivered over the f-dsch. The test verifies delivery of the maximum length short message on the f-dsch.

#### 2.3.1.2 Traceability

---

(See [1]):

2.4.1.1.2: Mobile SMS Message Termination

2.4.2.1.2: Base Station Traffic Channel Procedures

3.4.2.1: SMS Point-to-Point Message

3.4.3.5: Bearer Reply Option

#### 2.3.1.3 Method of Measurement

---

- a. Clear all short messages stored in the mobile station.
- b. Delete all outstanding short messages in the Network for the mobile station.
- c. Create in the Message Center a maximum size short message.
- d. Instruct the network to send the short message to the mobile station. Ensure the base station sends a *General Page Message* or *Universal Page Message* with either service option 6 or service option 14. Ensure that the base station sends a *Data Burst Message* to the mobile station on the f-dsch, with the following fields set as follows:

Field	Value
MSG_NUMBER	1 ('00000001')
BURST_TYPE	3 ('000011')
NUM_MSGS	1 ('00000001')
NUM_FIELDS	Greater than 0

- e. Upon receiving *Data Burst Message* at the mobile station, verify the following:

1. The mobile station alerts the user for the incoming short message and correctly displays the received short message or part of the received short message, when selected.
2. The mobile station transmits a r-dsch *Data Burst Message* to acknowledge the short message and indicating no error (i.e. contains a Cause Codes parameter having ERROR\_CLASS = '00').

#### **2.3.1.4 Minimum Standard**

---

The mobile station shall comply with step e.

#### **2.3.2 Base Station Test**

---

None.

1  
2  
3  
4  
5  
6  
7  
8  
9  
10  
11  
12  
13  
14  
15  
16  
17  
18  
19  
20  
21  
22  
23  
24  
25  
26  
27  
28  
29  
30  
31  
32  
33  
34  
35  
36  
37  
38  
39  
40  
41  
42  
43  
44  
45  
46  
47  
48  
49  
50  
51  
52  
53  
54  
55  
56  
57  
58  
59  
60

## 2.4 Common Channel SMS Delivery – Mobile Originated

---

### 2.4.1 Mobile Station Test

---

#### 2.4.1.1 Definition

---

This test verifies that a short message can be sent to the Message Center (MC) by a mobile station using the r-csch. The short message length chosen for this test is such that it doesn't exceed the maximum message length allowed on the r-csch.

#### 2.4.1.2 Traceability

---

(See [1]):

2.4.1.1.1.2: *Mobile SMS Message Origination*

2.4.2.1.1.1: *Mobile SMS Message Origination*

#### 2.4.1.3 Method of Measurement

---

- a. Power on the mobile station and wait until it is in the *Mobile Station Idle State*.
- b. Create a short message at the mobile station, of a length smaller than the maximum message length allowed on the r-csch, and instruct the mobile station to send the short message to the network<sup>1</sup>. Verify the mobile station sends a *Data Burst Message* to the base station over the r-csch with the following fields set as follows:

Field	Value
MSG_NUMBER	1 ('00000001')
BURST_TYPE	3 ('000011')
NUM_MSGS	1 ('00000001')
NUM_FIELDS	Greater than 0

- c. Ensure that the Message Center receives the short message and sends an SMS acknowledgement to the mobile station.

#### 2.4.1.4 Minimum Standard

---

The mobile station shall comply with step b.

<sup>1</sup> The maximum allowed size is dependent on the maximum access channel capsule size signaled in the *Access Parameters Message* and is also implementation dependent.

**2.4.2 Base Station Test**

---

None.

1  
2  
3  
4  
5  
6  
7  
8  
9  
10  
11  
12  
13  
14  
15  
16  
17  
18  
19  
20  
21  
22  
23  
24  
25  
26  
27  
28  
29  
30  
31  
32  
33  
34  
35  
36  
37  
38  
39  
40  
41  
42  
43  
44  
45  
46  
47  
48  
49  
50  
51  
52  
53  
54  
55  
56  
57  
58  
59  
60

## 2.5 Traffic Channel SMS Delivery – Mobile Originated

---

### 2.5.1 Mobile Station Test

---

#### 2.5.1.1 Definition

---

This test verifies a mobile station in the *Mobile Station Idle State* can originate a short message of length larger than the maximum length allowed on the r-csch and that the message is delivered to the Message Center over the r-dsch.

#### 2.5.1.2 Traceability

---

(See [1]) :

2.4.1.1.1.2: *Mobile SMS Message Origination*

2.4.2.1.2.2: *Base Station Traffic Channel Procedures*

#### 2.5.1.3 Method of Measurement

---

- a. Power on the mobile station and wait until it is in the *Mobile Station Idle State*.
- b. Create a short message at the mobile station, of a length larger than the maximum message length allowed on the r-csch, and instruct the mobile station to send the short message to the network
- c. Verify the following:
  1. The mobile station does not send the *Data Burst Message* over the r-csch.
  2. The mobile station sends an *Origination Message* to originate an SMS call with the SERVICE\_OPTION field set to either 6 or 14.
  3. After entering the *Conversation Substate*, the mobile station sends a *Data Burst Message*, with the following fields set as follows:

Field	Value
MSG_NUMBER	1 ('00000001')
BURST_TYPE	3 ('000011')
NUM_MSGS	1 ('00000001')
NUM_FIELDS	Greater than 0

- d. Ensure that the Message Center receives the short message and instruct the base station to send the SMS acknowledgement.

- e. Verify that upon sending the short message, the mobile station sends a *Release Order* to release the dedicated channels after receiving the SMS acknowledgement from the base station.

**2.5.1.4 Minimum Standard**

---

The mobile station shall comply with steps c and e.

**2.5.2 Base Station Test**

---

None.

1  
2  
3  
4  
5  
6  
7  
8  
9  
10  
11  
12  
13  
14  
15  
16  
17  
18  
19  
20  
21  
22  
23  
24  
25  
26  
27  
28  
29  
30  
31  
32  
33  
34  
35  
36  
37  
38  
39  
40  
41  
42  
43  
44  
45  
46  
47  
48  
49  
50  
51  
52  
53  
54  
55  
56  
57  
58  
59  
60

## 2.6 Traffic Channel SMS Delivery while in the Conversation Substate – Mobile Originated

---

### 2.6.1 Mobile Station Test

---

#### 2.6.1.1 Definition

---

This test verifies that a short message can be sent by the mobile station when it is in the *Conversation Substate*.

#### 2.6.1.2 Traceability

---

(See [1]):

2.4.1.1.1.2: Mobile SMS Message Origination

2.4.1.1.2.4: Mobile Station Message Origination in the Conversation Substate

2.4.2.1.1.1: Mobile SMS Message Origination

2.4.2.1.2.2: Base Station Traffic Channel Procedures

#### 2.6.1.3 Method of Measurement

---

- a. Set up a mobile station originated voice call.
- b. While mobile station is in the *Conversation Substate*, create a short message and instruct the mobile station to send the short message to the network. Verify the mobile station sends a *Data Burst Message*, with the following fields set as follows:

Field	Value
MSG_NUMBER	1 ('00000001')
BURST_TYPE	3 ('000011')
NUM_MSGS	1 ('00000001')
NUM_FIELDS	Greater than 0

- c. Ensure that the Message Center receives the short message.
- d. Verify that upon sending the short message, the mobile station does not attempt to release the dedicated channels.
- e. Repeat a-d with a packet data call.

#### 2.6.1.4 Minimum Standard

---

The mobile station shall comply with steps b and d.

**2.6.2 Base Station Test**

---

None.

1  
2  
3  
4  
5  
6  
7  
8  
9  
10  
11  
12  
13  
14  
15  
16  
17  
18  
19  
20  
21  
22  
23  
24  
25  
26  
27  
28  
29  
30  
31  
32  
33  
34  
35  
36  
37  
38  
39  
40  
41  
42  
43  
44  
45  
46  
47  
48  
49  
50  
51  
52  
53  
54  
55  
56  
57  
58  
59  
60

1  
2  
3  
4  
5  
6  
7  
8  
9  
10  
11  
12  
13  
14  
15  
16  
17  
18  
19  
20  
21  
22  
23  
24  
25  
26  
27  
28  
29  
30  
31  
32  
33  
34  
35  
36  
37  
38  
39  
40  
41  
42  
43  
44  
45  
46  
47  
48  
49  
50  
51  
52  
53  
54  
55  
56  
57  
58  
59  
60

No text.

# 3 SMS Transport Layer Test

Table 2 lists SMS Transport Layer tests.

Test No.	Title
3.1	SMS Acknowledgement Message
3.2	SMS Delivery Error - Mobile Station Short Message Buffer Full
3.3	SMS Delivery Error - Unknown Destination Address
3.4	SMS Delivery Error - Mobile Station Originated SMS Disabled
3.5	SMS Delivery Error - SMS Not Supported by Base Station
3.6	Authentication Upon SMS Originations
3.7	Broadcast SMS Delivery

**Table 2. SMS Transport Layer Tests**

1  
2  
3  
4  
5  
6  
7  
8  
9  
10  
11  
12  
13  
14  
15  
16  
17  
18  
19  
20  
21  
22  
23  
24  
25  
26  
27  
28  
29  
30  
31  
32  
33  
34  
35  
36  
37  
38  
39  
40  
41  
42  
43  
44  
45  
46  
47  
48  
49  
50  
51  
52  
53  
54  
55  
56  
57  
58  
59  
60

## 3.1 SMS Acknowledgement Message

---

### 3.1.1 Mobile Station Test

---

#### 3.1.1.1 Definition

---

This test verifies the mobile station sends the SMS Acknowledgement Message when the received SMS includes the Bearer Reply Option parameter. The mobile station shall set the Destination Address to the Originating Address and REPLY\_SEQ field in the Cause Codes parameter to the REPLY\_SEQ field in the Bearer Reply parameter of SMS message being acknowledged, respectively.

#### 3.1.1.2 Traceability

---

(See [1]):

3.3.2: End Point Procedures, Mobile Station

#### 3.1.1.3 Method of Measurement

---

- a. Delete all outstanding short messages in the network for the mobile station.
- b. Create in the Message Center a short message for the mobile station. Instruct the network to send the short message to the mobile station over the common channel or the f-dsch. Ensure that the base station sends a *Data Burst Message* to the mobile station, with the following fields set as follows:

Field	Value
MSG_NUMBER	1 ('00000001')
BURST_TYPE	3 ('000011')
NUM_MSGS	1 ('00000001')
NUM_FIELDS	Greater than 0

- c. Upon receiving the *Data Burst Message*, verify the following:
  1. The mobile station transmits an SMS Acknowledge Message with the following parameters as a *Data Burst Message* to acknowledge the short message.
    - a. Set the Destination Address parameter to the value of the Originating Address parameter and REPLY\_SEQ field in the Cause Codes parameter to the REPLY\_SEQ field in the Bearer Reply parameter of the SMS message being acknowledged.

### 3.1.1.4 Minimum Standard

---

The mobile station shall comply with step c.

## 3.1.2 Base Station Test

---

### 3.1.2.1 Definition

---

This test verifies the base station sends the SMS Acknowledgement Message when the received SMS includes the Bearer Reply Option parameter. The base station shall set the Originating Address to the Destination Address and REPLY\_SEQ field in the Cause Codes parameter to the REPLY\_SEQ field in the Bearer Reply parameter of SMS message being acknowledged, respectively. The base station should send the SMS acknowledgement Message within 18 seconds.

### 3.1.2.2 Traceability

---

(See [1]):

3.3.1: *Relay Point Procedures, Base Station*

3.4.2.1: *SMS Point-to-Point Message*

3.4.3.6: *Cause Codes*

### 3.1.2.3 Method of Measurement

---

- a. Power on the mobile station and wait until it is in the *Mobile Station Idle State*.
- b. Create a short message at the mobile station, with the Bearer Reply Option parameter set, and instruct the mobile station to send the short message to the base station. Ensure that the mobile station sends a *Data Burst Message*, with the following fields set as follows:

Field	Value
MSG_NUMBER	1 ('00000001')
BURST_TYPE	3 ('000011')
NUM_MSGS	1 ('00000001')
NUM_FIELDS	Greater than 0

- c. Upon receiving the *Data Burst Message* at the base station, verify the following:
  1. The base station should send an SMS Acknowledgement Message within 18 seconds.
  2. If base station sends SMS Acknowledgement Message, then the base station shall set the REPLY\_SEQ field in the Cause Codes parameter to the REPLY\_SEQ field in the Bearer Reply parameter of SMS message being acknowledged.

1  
2  
3  
4  
5  
6  
7  
8  
9  
10  
11  
12  
13  
14  
15  
16  
17  
18  
19  
20  
21  
22  
23  
24  
25  
26  
27  
28  
29  
30  
31  
32  
33  
34  
35  
36  
37  
38  
39  
40  
41  
42  
43  
44  
45  
46  
47  
48  
49  
50  
51  
52  
53  
54  
55  
56  
57  
58  
59  
60

### **3.1.2.4 Minimum Standard**

---

The base station shall comply with step c.

## 3.2 SMS Delivery Error - Mobile Station Short Message Buffer Full

---

### 3.2.1 Mobile Station Test

---

#### 3.2.1.1 Definition

---

This test verifies SMS transport layer acknowledgment capability by sending to the mobile station short messages until the mobile station short message buffer is full.

#### 3.2.1.2 Traceability

---

(See [1]):

2.4.1.1.1.1: Mobile SMS Message Termination

2.4.2.1.1: Common Channel Procedures

3.4.2.1: SMS Point-to-Point Message

3.4.3.6: Cause Codes

(See [4]):

6.5.2.125 SMS\_CauseCode

#### 3.2.1.3 Method of Measurement

---

- a. Clear all short messages stored in the mobile station to ensure that the short message buffer is empty.
- b. Delete all outstanding short messages in the network for the mobile station.
- c. Create in the Message Center a short message for the mobile station. Instruct the network to send the short message to the mobile station. Ensure that the base station sends a *Data Burst Message* to the mobile station, with the following fields set as follows:

Field	Value
MSG_NUMBER	1 ('00000001')
BURST_TYPE	3 ('000011')
NUM_MSGS	1 ('00000001')
NUM_FIELDS	Greater than 0

- 1  
2  
3  
4  
5  
6  
7  
8  
9  
10  
11  
12  
13  
14
- d. Upon receiving the *Data Burst Message*, verify that the mobile station transmits a *Data Burst Message* to acknowledge the short message and indicating no error (i.e. contains a Cause Codes parameter having ERROR\_CLASS = '00').
  - e. Repeat step c and d until the mobile station short message buffer is full.
  - f. Instruct the network to send one additional short message to the mobile station. Ensure that the base station sends a *Data Burst Message* to the mobile station, with the following fields set as follows:

Field	Value
MSG_NUMBER	1 ('00000001')
BURST_TYPE	3 ('000011')
NUM_MSGS	1 ('00000001')
NUM_FIELDS	Greater than 0

- 15  
16  
17  
18  
19  
20  
21  
22  
23  
24  
25  
26  
27  
28  
29  
30  
31
- g. Upon receiving the *Data Burst Message* sent in step f, verify that the mobile station transmits a *Data Burst Message* to acknowledge the short message and indicating temporary error (i.e. contains a Cause Codes parameter having ERROR\_CLASS = '10' and CAUSE\_CODE=35).

#### 3.2.1.4 Minimum Standard

---

The mobile station shall comply with steps d and g.

#### 3.2.2 Base Station Test

---

None.

## 3.3 SMS Delivery Error - Unknown Destination Address

### 3.3.1 Mobile Station Test

#### 3.3.1.1 Definition

This test verifies the mobile station can process a base station response regarding an unknown destination address.

#### 3.3.1.2 Traceability

(See [1]):

2.4.1.1.1.2: Mobile SMS Message Origination

2.4.2.1.2.2: Base Station Traffic Channel Procedures

3.4.2.1: SMS Point-to-Point Message

3.4.3.6: Cause Codes

#### 3.3.1.3 Method of Measurement

- a. Power on the mobile station and wait until it is in the Mobile Station Idle State.
- b. Create a short message at the mobile station, but with an unknown address in the destination address field, and instruct the mobile station to send the short message to the base station. Verify that the mobile station sends a *Data Burst Message*, with the following fields set as follows:

Field	Value
MSG_NUMBER	1 ('00000001')
BURST_TYPE	3 ('000011')
NUM_MSGS	1 ('00000001')
NUM_FIELDS	Greater than 0

- c. Instruct the base station to send a Data Burst Message to the mobile station indicating 'an unknown address' (i.e. contains a Cause Codes parameter having ERROR\_CLASS = '10' or '11' and CAUSE\_CODE=1).
- d. Verify that the mobile station receives the *Data Burst Message* sent by the base station.

### 3.3.1.4 Minimum Standard

---

The mobile station shall comply with steps b and d. The mobile station may display an indication of the message sending failure.

## 3.3.2 Base Station Test

---

### 3.3.2.1 Definition

---

This test verifies the base station can process a mobile station originated short message with an unknown destination address and will inform the mobile station regarding an unknown destination address.

### 3.3.2.2 Traceability

---

**(See [1]):**

2.4.1.1.1.2: *Mobile SMS Message Origination*

2.4.2.1.2.2: *Base Station Traffic Channel Procedures*

3.4.2.1: *SMS Point-to-Point Message*

3.4.3.6: *Cause Codes*

**(See [4]):**

6.5.2.125 *SMS\_CauseCode*

### 3.3.2.3 Method of Measurement

---

- a. Power on the mobile station and wait until it is in the *Mobile Station Idle State*.
- b. Create a short message at the mobile station, but with an unknown address in the destination address field, and instruct the mobile station to send the short message to the base station. Ensure that the mobile station sends a *Data Burst Message*, with the following fields set as follows:

Field	Value
MSG_NUMBER	1 ('00000001')
BURST_TYPE	3 ('000011')
NUM_MSGS	1 ('00000001')
NUM_FIELDS	Greater than 0

- c. Verify the Message Center receives the short message and the base station sends a *Data Burst Message* to the mobile station indicating 'an unknown address' (i.e. contains a Cause Codes parameter having ERROR\_CLASS = '10' or '11' and CAUSE\_CODE=1).

1  
2  
3  
4  
5  
6  
7  
8  
9  
10  
11  
12  
13  
14  
15  
16  
17  
18  
19  
20  
21  
22  
23  
24  
25  
26  
27  
28  
29  
30  
31  
32  
33  
34  
35  
36  
37  
38  
39  
40  
41  
42  
43  
44  
45  
46  
47  
48  
49  
50  
51  
52  
53  
54  
55  
56  
57  
58  
59  
60

**3.3.2.4 Minimum Standard**

---

The base station shall comply with step c. The mobile station may display an indication of the message sending failure.

## 3.4 SMS Delivery Error - Mobile Station Originated SMS Disabled

---

### 3.4.1 Mobile Station Test

#### 3.4.1.1 Definition

---

This test verifies that when a mobile station originated SMS is not activated in the network or the mobile station is not allowed to use mobile station originated SMS, the mobile station can process the base station indication that short message origination has been denied.

#### 3.4.1.2 Traceability

---

(See [1]):

2.4.1.1.1.2: *Mobile SMS Message Origination*

2.4.2.1.2.2: *Base Station Traffic Channel Procedures*

3.4.2.1: *SMS Point-to-Point Message*

3.4.3.6: *Cause Codes*

#### 3.4.1.3 Method of Measurement

---

- a. Ensure the mobile station originated short message feature for the mobile station is not activated in the network.
- b. Power on the mobile station and wait until it is in the Mobile Station Idle State.
- c. Create a short message at the mobile station, with the Bearer Reply Option parameter set, and instruct the mobile station to send the short message to the base station. Verify that the mobile station sends a Data Burst Message, with the following fields set as follows:

Field	Value
MSG_NUMBER	1 ('00000001')
BURST_TYPE	3 ('000011')
NUM_MSGS	1 ('00000001')
NUM_FIELDS	Greater than 0

- d. If the mobile station sends an *Origination Message* with an SMS service option (6 or 14), instruct the base station to send a *Release Order* with ORDQ = 2.. The mobile station may display an indication of the message sending failure Repeat steps a through d with the following variations in step d:

1. Instruct the base station to send a *Reorder Order*. The mobile station may display an indication of the message sending failure.
  2. Instruct the base station to assign a traffic channel. When the mobile station sends a r-dsch *Data Burst Message*, instruct the base station to send a *Data Burst Message* to the mobile station with an indication that SMS is not supported (i.e. contains a Cause Codes parameter having ERROR\_CLASS = '11' and CAUSE\_CODE=97). Verify the mobile station receives that *Data Burst Message* sent by the base station. The mobile station may display an indication of the message sending failure
- e. If the mobile station sends a r-csch *Data Burst Message*, instruct the base station to send a *Data Burst Message* on the f-csch to the mobile station, with an indication that SMS is not supported by this base station (i.e. contains a Cause Codes parameter having ERROR\_CLASS = '11' and CAUSE\_CODE=97).
1. Verify that the mobile station receives the *Data Burst Message* sent by the base station. The mobile station may display an indication of the message sending failure

#### 3.4.1.4 Minimum Standard

---

The mobile station shall comply with steps d or e. The mobile station may display an indication of the message sending failure.

### 3.4.2 Base Station Test

---

#### 3.4.2.1 Definition

---

This test verifies that when mobile station originated SMS is not activated in the network or the mobile station is not allowed to use mobile station originated SMS, the base station can process a mobile station originated short message and inform the mobile station that short message origination has been denied.

#### 3.4.2.2 Traceability

---

**(See [1]):**

2.4.1.1.1.2: *Mobile SMS Message Origination*

2.4.2.1.2.2: *Base Station Traffic Channel Procedures*

3.4.2.1: *SMS Point-to-Point Message*

3.4.3.6: *Cause Codes*

**(See [4]):**

6.5.2.125 *SMS\_CauseCode*

### 3.4.2.3 Method of Measurement

---

- a. Ensure the mobile station originated short message feature for the mobile station is not activated in the network.
- b. Power on the mobile station and wait until it is in the Mobile Station Idle State.
- c. Create a short message at the mobile station, with the Bearer Reply Option parameter set, and instruct the mobile station to send the short message to the base station. Ensure that the mobile station sends a *Data Burst Message*, with the following fields set as follows:

Field	Value
MSG_NUMBER	1 ('00000001')
BURST_TYPE	3 ('000011')
NUM_MSGS	1 ('00000001')
NUM_FIELDS	Greater than 0

- d. Verify the following:
  1. If the mobile station sends an *Origination Message* with an SMS service option (6 or 14), verify the following:
    - a. The base station sends a *Release Order* with ORDQ=2, or
    - b. The base station sends a *Reorder Order*, or
    - c. The traffic channel is assigned, the mobile station sends a r-dsch *Data Burst Message*, and the base station sends a *Data Burst Message* to the mobile station with an indication that SMS is not supported (i.e. contains a Cause Codes parameter having ERROR\_CLASS = '11' and CAUSE\_CODE=97).
  2. If the mobile station sends a r-csch *Data Burst Message*, verify the following:
    - a. The base station sends a *Data Burst Message* on the f-csch to the mobile station, with an indication that SMS is not supported by this base station (i.e. contains a Cause Codes parameter having ERROR\_CLASS = '11' and CAUSE\_CODE=97.)
  3. The base station does not route the short message to the Message Center.

### 3.4.2.4 Minimum Standard

---

The base station shall comply with step d. The mobile station may display an indication of the message sending failure.

## 3.5 SMS Delivery Error - SMS Not Supported by Base Station

### 3.5.1 Mobile Station Test

#### 3.5.1.1 Definition

This test verifies the mobile station can process a base station indication that SMS is not supported by the base station.

#### 3.5.1.2 Traceability

(See [1]):

2.4.1.1.1.2: *Mobile SMS Message Origination*

2.4.2.1.2.2: *Base Station Traffic Channel Procedures*

3.4.2.1: *SMS Point-to-Point Message*

3.4.3.6: *Cause Codes*

#### 3.5.1.3 Method of Measurement

- a. Ensure the base station is not capable of SMS or that SMS has been disabled for this test.
- b. Power on the mobile station and wait until it is in the *Mobile Station Idle State*.
- c. Create a short message at the mobile station, with Bearer Reply Option parameter set, and instruct the mobile station to send the short message to the network. Verify that the mobile station sends a *Data Burst Message*, with the following fields set as follows:

Field	Value
MSG_NUMBER	1 ('00000001')
BURST_TYPE	3 ('000011')
NUM_MSGS	1 ('00000001')
NUM_FIELDS	Greater than 0

- d. If the mobile station sends an *Origination Message* with an SMS service option (6 or 14), instruct the base station to send a *Release Order* with ORDQ = 2. The mobile station may display an indication of the message sending failure. Repeat steps a through d with the following variations in step d:
  1. Instruct the base station to send a *Reorder Order*. The mobile station may display an indication of the message sending failure.

- 1  
2  
3  
4  
5  
6  
7  
8  
9  
10  
11  
12  
13  
14  
15  
16  
17  
18  
19  
20  
21
2. Instruct the base station to assign a traffic channel. When the mobile station sends a r-dsch *Data Burst Message*, instruct the base station to send a *Data Burst Message* to the mobile station with an indication that SMS is not supported (i.e. contains a Cause Codes parameter having ERROR\_CLASS = '11' and CAUSE\_CODE=67 or 100). Verify the mobile station receives that *Data Burst Message* sent by the base station. The mobile station may display an indication of the message sending failure.
  - e. If the mobile station sends a r-csch *Data Burst Message*, instruct the base station to send a *Data Burst Message* on the f-csch to the mobile station, with an indication that SMS is not supported by this base station (i.e. contains a Cause Codes parameter having ERROR\_CLASS = '11' and CAUSE\_CODE=67 or 100).
    1. Verify that the mobile station receives the *Data Burst Message* sent by the base station. The mobile station may display an indication of the message sending failure.

#### 3.5.1.4 Minimum Standard

---

The mobile station shall comply with steps d or e. The mobile station may display an indication of the message sending failure.

### 3.5.2 Base Station Test

---

#### 3.5.2.1 Definition

---

This test verifies the base station can process a mobile station originated short message, and inform the mobile station that SMS is not supported by the base station.

#### 3.5.2.2 Traceability

---

**(See [1]):**

2.4.1.1.1.2: *Mobile SMS Message Origination*

2.4.2.1.2.2: *Base Station Traffic Channel Procedures*

3.4.2.1: *SMS Point-to-Point Message*

3.4.3.6: *Cause Codes*

**(See [4]):**

6.5.2.125 *SMS\_CauseCode*

#### 3.5.2.3 Method of Measurement

---

- 53  
54  
55  
56  
57  
58  
59  
60
- a. Ensure the base station is not capable of SMS or that SMS has been disabled for this test.
  - b. Power on the mobile station and wait until it is in the *Mobile Station Idle State*.

- c. Create a short message at the mobile station, with Bearer Reply Option parameter set, and instruct the mobile station to send the short message to the network. Ensure that the mobile station sends a *Data Burst Message*, with the following fields set as follows:

Field	Value
MSG_NUMBER	1 ('00000001')
BURST_TYPE	3 ('000011')
NUM_MSGS	1 ('00000001')
NUM_FIELDS	Greater than 0

- d. Verify the following:
1. If the mobile station sends an *Origination Message* with an SMS service option (6 or 14), verify the following:
    - a. The base station sends a *Release Order* with ORDQ=2, or
    - b. The base station sends a *Reorder Order*, or
    - c. The traffic channel is assigned, the mobile station sends a r-dsch *Data Burst Message*, and the base station sends a *Data Burst Message* to the mobile station with an indication that SMS is not supported (i.e. contains a Cause Codes parameter having ERROR\_CLASS = '11' and CAUSE\_CODE=67 or 100).
  2. If the mobile station sends a r-csch *Data Burst Message*, verify the following:
    - a. The base station sends a *Data Burst Message* on the f-csch to the mobile station, with an indication that SMS is not supported by this base station (i.e. contains a Cause Codes parameter having ERROR\_CLASS = '11' and CAUSE\_CODE=67 or 100).
  3. The base station does not route the short message to the Message Center.

#### 3.5.2.4 Minimum Standard

---

The base station shall comply with step d. The mobile station may display an indication of the message sending failure.

## 3.6 Authentication Upon SMS Originations

---

### 3.6.1 Mobile Station Test

---

#### 3.6.1.1 Definition

---

This test verifies the mobile station can successfully Authenticate upon SMS originations.

#### 3.6.1.2 Traceability

---

(See [1] ):

3.3.3: *Authentication Procedures*

#### 3.6.1.3 Method of Measurement

---

- a. Connect the base station and mobile station.
- b. Power on the mobile station.
- c. Initialize the A-Key to the same value in both the mobile station and base station.
- d. At the base station, initiate a Shared Secret Data update on the f-csch.
- e. Verify the SSD Update was successful.
- f. Send a mobile station originated SMS to a DTMF address (DIGIT\_MODE='0', NUMBER\_MODE='0', NUM\_FIELDS=10, CHARi [1]-[10]= 1234567890).
- g. Verify that Authentication is successful.
- h. Send a mobile station originated SMS to an 8-bit ASCII address (DIGIT\_MODE='1', NUMBER\_MODE='0', NUMBER\_TYPE='001', NUM\_FIELDS=11, CHARi [1]-[11]= 11234567890, NUMBER\_PLAN).
- i. Verify that Authentication is successful.
- j. Send a mobile station originated SMS to a data network address (DIGIT\_MODE='1', NUMBER\_MODE='1' and NUMBER\_TYPE='001', NUM\_FIELDS=4, CHARi [1]-[4]=129.54.75.205).
- k. Verify that Authentication is successful.
- l. Send a mobile station originated SMS to an Internet e-mail address (DIGIT\_MODE='1', NUMBER\_MODE='1' and NUMBER\_TYPE='010', NUM\_FIELDS=11, CHARi [1]-[11]=abc@123.com).
- m. Verify that Authentication is successful.

#### 3.6.1.4 Minimum Standard

---

The mobile station shall comply with steps e, g, i, k, and m.

**3.6.2 Base Station Test**

---

None.

1  
2  
3  
4  
5  
6  
7  
8  
9  
10  
11  
12  
13  
14  
15  
16  
17  
18  
19  
20  
21  
22  
23  
24  
25  
26  
27  
28  
29  
30  
31  
32  
33  
34  
35  
36  
37  
38  
39  
40  
41  
42  
43  
44  
45  
46  
47  
48  
49  
50  
51  
52  
53  
54  
55  
56  
57  
58  
59  
60

## 3.7 Broadcast SMS Delivery

### 3.7.1 Mobile Station Test

#### 3.7.1.1 Definition

This test verifies that mobile stations configured to receive broadcast SMS are able to receive broadcast SMS messages sent by the network.

#### 3.7.1.2 Traceability

(See [1]):

2.4.1.2.1: Common Channel Procedures for Broadcast SMS

4.3.1.3: Broadcast Messaging Service

#### 3.7.1.3 Method of Measurement

- a. Connect the base station and mobile stations as shown in Figure 2.

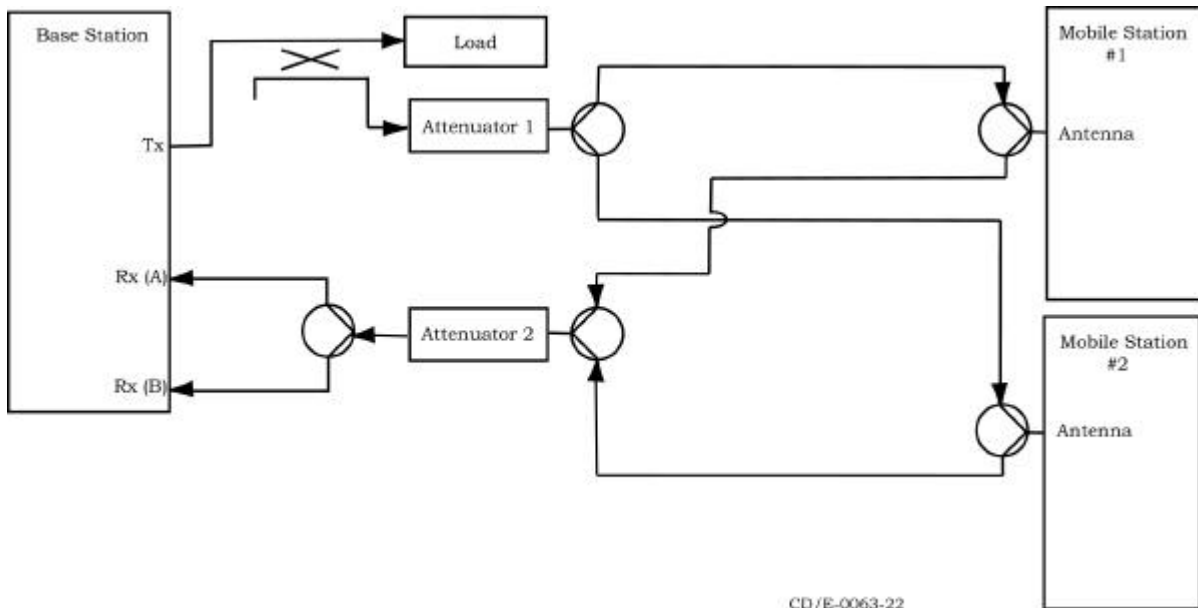

Figure 2 Functional Setup for Broadcast SMS Tests

- b. Ensure mobile station 1 is configured to receive broadcast SMS with normal priority while mobile station 2 is configured to receive broadcast SMS with emergency priority. Also

ensure that both mobile stations are configured to receive other filtering categories (i.e. service and language) for this test.

- c. Power on the mobile stations and wait until they are registered.
- d. Clear any outstanding broadcast messages in the network.
- e. Create broadcast message 1 shown in Table 3 and instruct the network to broadcast it. Ensure that the base station sends a *Data Burst Message*, with the following fields set as follows:

Field	Value
MSG_NUMBER	1 ('00000001')
BURST_TYPE	3 ('000011')
NUM_MSGS	1 ('00000001')
NUM_FIELDS	Greater than 0

Broadcast Message	Broadcast Message Priority	Priority Indicator Value
Message 1	Normal	00
Message 2	Emergency	11

**Table 3. Broadcast Messages and Priority**

- f. Upon receiving the *Data Burst Message*, verify that mobile station 1 displays broadcast message 1 (as a Normal message, if such display is supported) and mobile station 2 does not.
- g. Create broadcast message 2 (as an emergency message) shown in Table 3 and instruct the network to broadcast it. Ensure that the base station sends a *Data Burst Message*, with the following fields set as follows:

Field	Value
MSG_NUMBER	1 ('00000001')
BURST_TYPE	3 ('000011')
NUM_MSGS	1 ('00000001')
NUM_FIELDS	Greater than 0

- h. Upon receiving the *Data Burst Message*, verify both mobile stations display broadcast message 2 (as an Emergency message, if such a display is supported).

1  
2  
3  
4  
5  
6  
7  
8  
9  
10  
11  
12  
13  
14  
15  
16  
17  
18  
19  
20  
21  
22  
23  
24  
25  
26  
27  
28  
29  
30  
31  
32  
33  
34  
35  
36  
37  
38  
39  
40  
41  
42  
43  
44  
45  
46  
47  
48  
49  
50  
51  
52  
53  
54  
55  
56  
57  
58  
59  
60

**3.7.1.4 Minimum Standard**

---

The mobile station shall comply with steps f and h.

**3.7.2 Base Station Test**

---

None.

No text.

- 1
- 2
- 3
- 4
- 5
- 6
- 7
- 8
- 9
- 10
- 11
- 12
- 13
- 14
- 15
- 16
- 17
- 18
- 19
- 20
- 21
- 22
- 23
- 24
- 25
- 26
- 27
- 28
- 29
- 30
- 31
- 32
- 33
- 34
- 35
- 36
- 37
- 38
- 39
- 40
- 41
- 42
- 43
- 44
- 45
- 46
- 47
- 48
- 49
- 50
- 51
- 52
- 53
- 54
- 55
- 56
- 57
- 58
- 59
- 60



## 4 SMS Teleservice Layer Test

Test No.	Title
4.1	Voice Mail Notification
4.2	Setting of Message Identifier Field
4.3	Unique Message Identification
4.4	User Acknowledgement Request
4.5	SMS Delivery Acknowledgement Request
4.6	Read Acknowledgement Request
4.7	Mobile Station Terminated EMS Tests:
4.7.1	Concatenated Short Message EMS Message Delivery
4.7.2	Delivery of Predefined EMS Information Elements:
4.7.2.1	Delivery of Predefined Sound Elements
4.7.2.2	Delivery of Predefined Animation Elements
4.7.3	Delivery of User Defined EMS Information Elements
4.7.3.1	Delivery of User Defined Sound Elements
4.7.3.2	Delivery of User Defined Animation Elements
4.7.3.3	Delivery of User Defined Picture Elements
4.7.4	Delivery of Formatted Text
4.8	Mobile Station Originated EMS Tests:
4.8.1	Concatenated Short Message EMS Message Delivery:
4.8.2	Delivery of Predefined EMS Information Elements:
4.8.2.1	Delivery of Predefined Sound Elements
4.8.2.2	Delivery of Predefined Animation Elements
4.8.3	Delivery of User Defined EMS Information Elements
4.8.3.1	Delivery of User Defined Sound Elements
4.8.3.2	Delivery of User Defined Animation Elements
4.8.3.3	Delivery of User Defined Picture Elements
4.8.4	Delivery of Formatted Text

1  
2  
3  
4  
5  
6  
7  
8  
9  
10  
11  
12  
13  
14  
15  
16  
17  
18  
19  
20  
21  
22  
23  
24  
25  
26  
27  
28  
29  
30  
31  
32  
33  
34  
35  
36  
37  
38  
39  
40  
41  
42  
43  
44  
45  
46  
47  
48  
49  
50  
51  
52  
53  
54  
55  
56  
57  
58  
59  
60

**Table 4. SMS Teleservice Layer Tests**

## 4.1 Voice Mail Notification

---

### 4.1.1 Mobile Station Test

---

#### 4.1.1.1 Definition

---

Voice Mail Notification (VMN) notifies the subscriber of voice mail messages using the Voice Mail Notification teleservice and Short Message Service protocol. Notification can be a tone, light, or display, and is manufacturer dependent.

#### 4.1.1.2 Traceability

---

(See [1] ):

4.3.5: Voice Mail Notification (VMN)

4.5.12: Number of Messages

#### 4.1.1.3 Method of Measurement

---

- a. Power on the mobile station and wait until it is in the *Mobile Station Idle State*.
- b. Instruct the network to send a Voice Mail Notification (corresponds to an SMS Point-to-Point message) to the mobile station. Ensure that the base station sends a *Data Burst Message*, with the BURST\_TYPE field set to '000011', with the following parameters of the SMS message set as follows:
  1. Teleservice Identifier parameter, IDENTIFIER = Voice Mail Notification (0x1003).
  2. Message Identifier subparameter, MESSAGE\_TYPE = Deliver (0x1).
  3. Number of Messages subparameter, MESSAGE\_CT = 99.
- c. Upon receiving the *Data Burst Message*, verify that the following:
  1. The mobile station transmits an SMS Acknowledge message via a *Data Burst Message* to acknowledge the short message and indicating no error (i.e. contains a Cause Codes parameter having ERROR\_CLASS = '00').
  2. The mobile station indicates to the user 99 voice mail messages available as indicated by the network.
- d. Repeat steps b and c, setting the MESSAGE\_CT = 0.
- e. Upon receiving the *Data Burst Message*, verify that the mobile station indicates to the user no voice mail messages are available.

#### 4.1.1.4 Minimum Standard

---

The mobile station shall comply with steps c and e.

1  
2  
3  
4  
5  
6  
7  
8  
9  
10  
11  
12  
13  
14  
15  
16  
17  
18  
19  
20  
21  
22  
23  
24  
25  
26  
27  
28  
29  
30  
31  
32  
33  
34  
35  
36  
37  
38  
39  
40  
41  
42  
43  
44  
45  
46  
47  
48  
49  
50  
51  
52  
53  
54  
55  
56  
57  
58  
59  
60

## **4.1.2 Base Station Test**

---

None.

## 4.2 Setting of Message Identifier Field

### 4.2.1 Mobile Station Test

#### 4.2.1.1 Definition

The MESSAGE\_ID field of the Message Identifier Subparameter is a value used to identify sent SMS messages. The mobile station shall increment the MESSAGE\_ID field, modulo 65536, for each new message sent. This test is not applicable to the WAP Teleservice.

#### 4.2.1.2 Traceability

(See [1]):

4.3.1.5: Setting of the Message Identifier Field

#### 4.2.1.3 Method of Measurement

- a. Power on the mobile station and wait until it is in the *Mobile Station Idle State*.
- b. Create a short message at the mobile station and instruct the mobile station to send the short message to the base station. Verify the mobile station sends a *Data Burst Message* with following values:

Field	Value
MSG_NUMBER	1 ('00000001')
BURST_TYPE	3 ('000011')
NUM_MSGS	1 ('00000001')
NUM_FIELDS	Greater than 0

- c. Upon receiving the *Data Burst Message* at the base station, record the value of MESSAGE\_ID field.
- d. Create another short message at the mobile station and instruct the mobile station to send the short message to the base station. Verify the mobile station sends a *Data Burst Message*.
- e. Upon receiving the *Data Burst Message* at the base station, record the value of MESSAGE\_ID field. Verify the value has been incremented modulo 65536 by the mobile station.

1  
2  
3  
4  
5  
6  
7  
8  
9  
10  
11  
12  
13  
14  
15  
16  
17  
18  
19  
20  
21  
22  
23  
24  
25  
26  
27  
28  
29  
30  
31  
32  
33  
34  
35  
36  
37  
38  
39  
40  
41  
42  
43  
44  
45  
46  
47  
48  
49  
50  
51  
52  
53  
54  
55  
56  
57  
58  
59  
60

**4.2.1.4 Minimum Standard**

---

The mobile station shall comply with step e.

**4.2.2 Base Station Test**

---

None.

## 4.3 Unique Message Identification – Mobile Terminated

### 4.3.1 Mobile Station Test

#### 4.3.1.1 Definition

This test verifies the mobile station can identify repeated messages and to process them accordingly. The mobile station shall use as many of the fields as are present in the SMS message to determine message uniqueness. The fields used to identify a message are Message Identifier, Originating Address, Originating Subaddress and Message Center Time Stamp. The Originating Subaddress is not used in this test. This test is not applicable to the WAP Teleservice.

#### 4.3.1.2 Traceability

(See [1]):

4.3.1.1: Mobile Station Message Termination

4.3.1.6: Unique Message Identification

#### 4.3.1.3 Method of Measurement

- a. Clear all short messages stored in the mobile station.
- b. Delete all outstanding short messages in the network for the mobile station.
- c. Create in the Message Center a short message for the mobile station. Instruct the base station to send the short message with the Message Identifier, the Originating Address and the Message Center Time Stamp (if supported). Ensure that the base station sends a *Data Burst Message* to the mobile station, with the following fields set as follows:

Field	Value
MSG_NUMBER	1 ('00000001')
BURST_TYPE	3 ('000011')
NUM_MSGS	1 ('00000001')
NUM_FIELDS	Greater than 0

- d. Upon receiving the *Data Burst Message*, verify that the mobile station transmits a *Data Burst Message* to acknowledge the short message and indicating no error (i.e. contains a Cause Codes parameter having ERROR\_CLASS = '00').

1  
2  
3  
4  
5  
6  
7  
8  
9  
10  
11  
12  
13  
14  
15  
16  
17  
18  
19  
20  
21  
22  
23  
24  
25  
26  
27  
28  
29  
30  
31  
32  
33  
34  
35  
36  
37  
38  
39  
40  
41  
42  
43  
44  
45  
46  
47  
48  
49  
50  
51  
52  
53  
54  
55  
56  
57  
58  
59  
60

- e. Create in the Message Center one additional short message with the same Message Identifier, Originating Address and Message Center Time Stamp as previously sent in step c. Instruct the network to send the short message to the mobile station. Ensure that the base station sends a *Data Burst Message* to the mobile station.
- f. Upon receiving the *Data Burst Message* sent in step e the mobile station shall transmit a *Data Burst Message* to acknowledge the short message and indicating no error (i.e. contains a Cause Codes parameter having ERROR\_CLASS = '00'):
- g. Upon receiving the *Data Burst Message* sent in step d. The mobile station should discard the second short message

**4.3.1.4 Minimum Standard**

---

The mobile station shall comply with steps d and f. The mobile station should comply with step g.

**4.3.2 Base Station Test**

---

None.

## 4.4 User Acknowledgement Request

---

### 4.4.1 Mobile Station Test

---

#### 4.4.1.1 Definition

---

This test verifies SMS teleservice layer acknowledgment capability by sending an *SMS Deliver Message* indicating that the User Acknowledgement is requested. This test is applicable only if the mobile station supports the User Acknowledgement and indication of the request to the user upon receiving the *SMS Delivery Message*.

#### 4.4.1.2 Traceability

---

(See [1]):

4.3.1.1: *Mobile Station Message Termination*

4.5.11: *Reply Option*

#### 4.4.1.3 Method of Measurement

---

- a. Delete all outstanding short messages in the network for the mobile station.
- b. Create in the Message Center a short message for the mobile station. Instruct the network to send the short message to the mobile station. Ensure that the base station sends an *SMS Deliver Message* to the mobile station, with the following fields in the Reply Option subparameter set as follows:

Field	Value
USER_ACK_REQ	1 ('1')

- c. Upon receiving the *SMS Deliver Message*, the mobile station should indicate the request to the user.
- d. When the user acknowledges the message, the mobile station should send an *SMS User Acknowledgement Message* in response to the *SMS Deliver Message*.
- e. If the mobile station sends *SMS User Acknowledgement Message*, then the message contents shall be as follows:
  1. The Destination Address parameter is set to the Originating Address field of the SMS message being acknowledged.
  2. The MESSAGE\_ID field of the Message Identifier subparameter is set to the value of the MESSAGE\_ID field in the SMS message being acknowledged.

1  
2  
3  
4  
5  
6  
7  
8  
9  
10  
11  
12  
13  
14  
15  
16  
17  
18  
19  
20  
21  
22  
23  
24  
25  
26  
27  
28  
29  
30  
31  
32  
33  
34  
35  
36  
37  
38  
39  
40  
41  
42  
43  
44  
45  
46  
47  
48  
49  
50  
51  
52  
53  
54  
55  
56  
57  
58  
59  
60

**4.4.1.4 Minimum Standard**

---

The mobile station should comply with steps c and d. The mobile station shall comply with step e.

**4.4.2 Base Station Test**

---

None.

## 4.5 SMS Delivery Acknowledgement Request

---

### 4.5.1 Mobile Station Test

---

None.

### 4.5.2 Base Station Test

---

#### 4.5.2.1 Definition

---

This test verifies SMS teleservice layer acknowledgment capability by sending an *SMS Submit Message* indicating that the *SMS Delivery Acknowledgement* is requested.

#### 4.5.2.2 Traceability

---

(See [1]):

4.3.1.1: *Mobile Station Message Termination*

4.5.11: *Reply Option*

#### 4.5.2.3 Method of Measurement

---

- a. Power on the mobile station and wait until it is in the *Mobile Station Idle State*.
- b. Create a short message at the mobile station, with the Reply Option subparameter set, and instruct the mobile station to send the short message to the base station. Ensure that the mobile station sends an *SMS Submit Message*, with the following fields set as follows:

Field	Value
DAK_REQ	1 ('1')

- c. Upon receiving the *SMS Submit Message* at the message center, verify the following:
  1. The message center sends the *SMS Delivery Acknowledgement Message* to the originating mobile station when the final destination confirms receipt of the submitted message.
  2. The MESSAGE\_ID field of the Message Identifier subparameter is set to the value of the MESSAGE\_ID field in the SMS message being acknowledged.

#### 4.5.2.4 Minimum Standard

---

The base station shall comply with step c.

1  
2  
3  
4  
5  
6  
7  
8  
9  
10  
11  
12  
13  
14  
15  
16  
17  
18  
19  
20  
21  
22  
23  
24  
25  
26  
27  
28  
29  
30  
31  
32  
33  
34  
35  
36  
37  
38  
39  
40  
41  
42  
43  
44  
45  
46  
47  
48  
49  
50  
51  
52  
53  
54  
55  
56  
57  
58  
59  
60

## 4.6 Read Acknowledgement Request

### 4.6.1 Mobile Station Test

#### 4.6.1.1 Definition

This test verifies SMS teleservice layer acknowledgment capability by sending an *SMS Deliver Message* indicating that the Read Acknowledgement is requested. This test is applicable only if the mobile station supports the Read Acknowledgement.

#### 4.6.1.2 Traceability

(See [1]):

4.3.1.1: *Mobile Station Message Termination*

4.5.11: *Reply Option*

#### 4.6.1.3 Method of Measurement

- a. Delete all outstanding short messages in the network for the mobile station.
- b. Create in the Message Center a short message for the mobile station. Instruct the network to send the short message to the mobile station. Ensure that the base station sends an *SMS Deliver Message* to the mobile station, with the following fields in the Reply Option subparameter set as follows:

Field	Value
READ_ACK_REQ	1 ('1')

- c. Upon receiving the *SMS Deliver Message*, the mobile station should indicate the request to the user.
- d. When the user opens the message, the mobile station should send an *SMS Read Acknowledgement Message* in response to the *SMS Deliver Message*.
- e. If the mobile station sends *SMS Read Acknowledgement Message*, then the message contents shall be as follows:
  1. The Destination Address parameter is set to the Originating Address field of the SMS message being acknowledged.
  2. The MESSAGE\_ID field of the Message Identifier subparameter is set to the value of the MESSAGE\_ID field in the SMS message being acknowledged.

1  
2  
3  
4  
5  
6  
7  
8  
9  
10  
11  
12  
13  
14  
15  
16  
17  
18  
19  
20  
21  
22  
23  
24  
25  
26  
27  
28  
29  
30  
31  
32  
33  
34  
35  
36  
37  
38  
39  
40  
41  
42  
43  
44  
45  
46  
47  
48  
49  
50  
51  
52  
53  
54  
55  
56  
57  
58  
59  
60

**4.6.1.4 Minimum Standard**

---

The mobile station should comply with steps c and d. The mobile station shall comply with step e.

**4.6.2 Base Station Test**

---

None.

## 4.7 Mobile Station Terminated Enhanced Messaging Services [EMS] Tests:

---

Unless otherwise noted, the following conditions apply for all tests in this section:

- ?? Mobile station is capable of receiving Enhanced Messaging Services [EMS] messages.
- ?? The EMS message feature for the mobile station is activated.
- ?? *Transport Layer* messages shall enable the Bearer Reply Option.
- ?? SMS message carries Teleservice ID parameter is set to WEMT, and HEAD\_IND of Message Identifier subparameter is set to '1'.

### 4.7.1 Concatenated Short Message EMS Message Delivery

---

#### 4.7.1.1 Mobile Station Test

---

##### 4.7.1.1.1 Definition

---

This test verifies the mobile station's ability to receive and properly display Concatenated Short Message EMS messages.

##### 4.7.1.1.2 Traceability

---

**(See. [1]);**

4.3.7: *Wireless Enhanced Messaging Teleservice*

2.4.1.1.1.1: *Mobile SMS Message Termination*

**(See. [2]);**

9.2.3.24: *TP-User Data (TP-UD)*

##### 4.7.1.1.3 Method of Measurement

---

- a. Delete all outstanding short messages in the network for the mobile station. Delete all short messages in the mobile station.
- b. Create an EMS message in the Message Center for the mobile station, consisting of multiple segments.
- c. Instruct the Message Center to send the first segment of the EMS message to the mobile station.
- d. Ensure that the base station sends the first *Data Burst Message* to the mobile station, with the following fields set as follows:

Field	Value
MSG_NUMBER	1 ('00000001')
BURST_TYPE	3 ('000011')
NUM_MSGS	1 ('00000001')
NUM_FIELDS	Greater than 0

- e. Verify that the mobile station transmits a *Data Burst Message* to acknowledge the received *Data Burst Message*, and indicates no error (i.e. containing Cause Codes parameter having ERROR\_CLASS = '00').
- f. Instruct the Message Center to send the remaining segments of the EMS message to the mobile station.
- g. Ensure that the base station sends the remaining *Data Burst Messages* to the mobile station, with the following fields set as follows:

Field	Value
MSG_NUMBER	1 ('00000001')
BURST_TYPE	3 ('000011')
NUM_MSGS	1 ('00000001')
NUM_FIELDS	Greater than 0

- h. Verify that the mobile station transmits a *Data Burst Message* to acknowledge each received *Data Burst Message*, containing a message segment, and indicates no error (i.e. contains Cause Codes parameters having ERROR\_CLASS = '00').
- i. Upon receiving all the *Data Burst Messages* at the mobile station, verify the following:
1. The mobile station alerts the user for the incoming EMS message and correctly displays the received message, when selected.
  2. Verify that all the segments of the EMS message segments sent are properly displayed in correct order.

#### 4.7.1.1.4 Minimum Standard

---

The mobile station shall comply with steps e, h, and i.

#### 4.7.1.2 Base Station Test

---

None.

## 4.7.2 Delivery of Predefined EMS Information Elements

---

This section tests the mobile stations ability to receive and display pre-defined information elements.

### 4.7.2.1 Delivery of Predefined Sound Elements

---

#### 4.7.2.1.1 Mobile Station Test

---

##### 4.7.2.1.1.1 Definition

---

This test verifies mobile station's ability to receive and properly play pre-defined EMS sound elements (Information Element Identifier 0x0B), if supported.

##### 4.7.2.1.1.2 Traceability

---

(See. [1]);

4.3.7: *Wireless Enhanced Messaging Teleservice*

2.4.1.1.1.1: *Mobile SMS Message Termination*

(See. [2]):

9.2.3.24 T: *P-User Data (TP-UD)*

##### 4.7.2.1.1.3 Method of Measurement

---

- a. Delete all outstanding short messages in the network for the mobile station. Delete all short messages in the mobile station.
- b. Create an EMS message in the Message Center for the mobile station. In the message include (1) one predefined sound element.
- c. Power on the mobile station and wait until it is in the *Mobile Station Idle State*.
- d. Instruct the network to send the EMS message to the mobile station.
- e. Ensure that the base station sends a *Data Burst Message* to the mobile station with the specified fields set as follows:

Field	Value
MSG_NUMBER	1 ('00000001')
BURST_TYPE	3 ('000011')
NUM_MSGS	1 ('00000001')
NUM_FIELDS	Greater than 0

1  
2  
3  
4  
5  
6  
7  
8  
9  
10  
11  
12  
13  
14  
15  
16  
17  
18  
19  
20  
21  
22  
23  
24  
25  
26  
27  
28  
29  
30  
31  
32  
33  
34  
35  
36  
37  
38  
39  
40  
41  
42  
43  
44  
45  
46  
47  
48  
49  
50  
51  
52  
53  
54  
55  
56  
57  
58  
59  
60

- a. Upon receiving *Data Burst Message* at the mobile station, verify the following:
1. The mobile station alerts the user for the incoming message and correctly displays the received message, when selected.
  2. The mobile station properly plays the predefined sound, when selected.
  3. The mobile station transmits a *Data Burst Message* to acknowledge the EMS message, indicating no error (i.e. contains a Cause Codes parameter having ERROR\_CLASS = '00').

**4.7.2.1.1.4 Minimum Standard**

---

The mobile station shall comply with step f.

**4.7.2.1.2 Base Station Test**

---

None.

## 4.7.2.2 Delivery of Predefined Animation Elements

---

### 4.7.2.2.1 Mobile Station Test

---

#### 4.7.2.2.1.1 Definition

---

This test verifies the mobile station's ability to compose and send messages containing predefined EMS animation elements (Information Element Identifier 0x0D), if supported.

#### 4.7.2.2.1.2 Traceability

---

**(Ref. [1] );**

4.3.7: *Wireless Enhanced Messaging Teleservice*

2.4.1.1.1.2: *Mobile SMS Message Origination*

**(Ref. [2] );**

9.2.3.24: *TP-User Data (TP-UD)*

#### 4.7.2.2.1.3 Method of Measurement

---

- a. Power on the mobile station and wait until it is in the *Mobile Station Idle State*.
- b. Create an EMS message at the mobile station. In the message include (1) one predefined animation object.
- c. Instruct the mobile station to send the EMS message to the Message Center.
- d. Verify the mobile station sends a *Data Burst Message* to the base station with the fields set as follows:

Field	Value
MSG_NUMBER	1 ('00000001')
BURST_TYPE	3 ('000011')
NUM_MSGS	1 ('00000001')
NUM_FIELDS	Greater than 0

- e. Ensure that the Message Center receives *Data Burst Message* and sends the SMS acknowledgement to the mobile station.

1  
2  
3  
4  
5  
6  
7  
8  
9  
10  
11  
12  
13  
14  
15  
16  
17  
18  
19  
20  
21  
22  
23  
24  
25  
26  
27  
28  
29  
30  
31  
32  
33  
34  
35  
36  
37  
38  
39  
40  
41  
42  
43  
44  
45  
46  
47  
48  
49  
50  
51  
52  
53  
54  
55  
56  
57  
58  
59  
60

- f. Verify that the EMS message sent from the test mobile station contains the predefined animation object.

**4.7.2.2.1.4 Minimum Standard**

---

The mobile station shall comply with steps d and f.

**4.7.2.2.2 Base Station Test**

---

None.

## 4.7.3 Delivery of User Defined EMS Information Elements

This section tests the mobile stations ability to receive and display user defined information elements.

### 4.7.3.1 Delivery of User Defined Sound Elements

#### 4.7.3.1.1 Mobile Station Test

##### 4.7.3.1.1.1 Definition

This test verifies mobile station's ability to receive and properly play user defined (iMelody) EMS sound elements (Information Element Identifier 0x0C), if supported.

##### 4.7.3.1.1.2 Traceability

**(See. [1]):**

4.3.7: *Wireless Enhanced Messaging Teleservice*

2.4.1.1.1.1: *Mobile SMS Message Termination*

**(See. [2]):**

9.2.3.24: *TP-User Data (TP-UD)*

##### 4.7.3.1.1.3 Method of Measurement

- a. Delete all outstanding short messages in the network for the mobile station. Delete all short messages in the mobile station.
- b. Create an EMS message in the Message Center for the mobile station. In the message include (1) one user defined iMelody sound object.
- c. Power on the mobile station and wait until it is in the *Mobile Station Idle State*.
- d. Instruct the network to send the EMS message to the mobile station.
- e. Ensure that the base station sends a *Data Burst Message* to the mobile station with the specified fields set as follows:

Field	Value
MSG_NUMBER	1 ('00000001')
BURST_TYPE	3 ('000011')
NUM_MSGS	1 ('00000001')
NUM_FIELDS	Greater than 0

1  
2  
3  
4  
5  
6  
7  
8  
9  
10  
11  
12  
13  
14  
15  
16  
17  
18  
19  
20  
21  
22  
23  
24  
25  
26  
27  
28  
29  
30  
31  
32  
33  
34  
35  
36  
37  
38  
39  
40  
41  
42  
43  
44  
45  
46  
47  
48  
49  
50  
51  
52  
53  
54  
55  
56  
57  
58  
59  
60

- f. Upon receiving *Data Burst Message* at the mobile station, verify the following:
1. The mobile station alerts the user for the incoming message and correctly displays the received message, when selected.
  2. The mobile station properly plays the iMelody sound object, when selected. Verify that the iMelody being played is the same as the one being transmitted.
  3. The mobile station transmits a *Data Burst Message* to acknowledge the EMS message, indicating no error (i.e. contains a Cause Codes parameter having ERROR\_CLASS = '00').

**4.7.3.1.1.4 Minimum Standard**

---

The mobile station shall comply with step f.

**4.7.3.1.2 Base Station Test**

---

None.

## 4.7.3.2 Delivery of User Defined Animation Elements

---

### 4.7.3.2.1 Mobile Station Test

---

#### 4.7.3.2.1.1 Definition

---

This test verifies mobile station's ability to receive and properly play user defined EMS animation elements (Information Element Identifier 0x0E or 0x0F), if supported.

#### 4.7.3.2.1.2 Traceability

---

(See. [1]):

4.3.7: *Wireless Enhanced Messaging Teleservice*

2.4.1.1.1.1: *Mobile SMS Message Termination*

(See. [2]):

9.2.3.2: *TP-User Data (TP-UD)*

#### 4.7.3.2.1.3 Method of Measurement

---

- a. Delete all outstanding short messages in the network for the mobile station. Delete all short messages in the mobile station.
- b. Create an EMS message in the Message Center for the mobile station. In the message include (1) one user defined animation object.
- c. Power on the mobile station and wait until it is in the *Mobile Station Idle State*.
- d. Instruct the network to send the EMS message to the mobile station.
- e. Ensure that the base station sends a *Data Burst Message* to the mobile station with the specified fields set as follows:

Field	Value
MSG_NUMBER	1 ('00000001')
BURST_TYPE	3 ('000011')
NUM_MSGS	1 ('00000001')
NUM_FIELDS	Greater than 0

- f. Upon receiving *Data Burst Message* at the mobile station, verify the following:

1  
2  
3  
4  
5  
6  
7  
8  
9  
10  
11  
12  
13  
14  
15  
16  
17  
18  
19  
20  
21  
22  
23  
24  
25  
26  
27  
28  
29  
30  
31  
32  
33  
34  
35  
36  
37  
38  
39  
40  
41  
42  
43  
44  
45  
46  
47  
48  
49  
50  
51  
52  
53  
54  
55  
56  
57  
58  
59  
60

1. The mobile station alerts the user for the incoming message and correctly displays the received message, when selected.
2. The mobile station properly plays the animation, when selected.
3. The mobile station transmits a *Data Burst Message* to acknowledge the EMS message, indicating no error (i.e. contains a Cause Codes parameter having ERROR\_CLASS = '00').

**4.7.3.2.1.4 Minimum Standard**

---

The mobile station shall comply with step f.

**4.7.3.2.2 Base Station Test**

---

None.

### 4.7.3.3 Delivery of User Defined Picture Elements

---

#### 4.7.3.3.1 Mobile Station Test

---

##### 4.7.3.3.1.1 Definition

---

This test verifies mobile station's ability to receive and properly display user defined EMS picture elements (Information Element Identifier 0x10 or 0x11), if supported.

##### 4.7.3.3.1.2 Traceability

---

(See. [1]);

4.3.7: *Wireless Enhanced Messaging Teleservice*

2.4.1.1.1.1: *Mobile SMS Message Termination*

(See. [2]):

9.2.3.24: *TP-User Data (TP-UD)*

##### 4.7.3.3.1.3 Method of Measurement

---

- a. Delete all outstanding short messages in the network for the mobile station. Delete all short messages in the mobile station.
- b. Create an EMS message in the Message Center for the mobile station. In the message include (1) one user defined picture object.
- c. Power on the mobile station and wait until it is in the *Mobile Station Idle State*.
- d. Instruct the network to send the EMS message to the mobile station.
- e. Ensure that the base station sends a *Data Burst Message* to the mobile station with the specified fields set as follows:

Field	Value
MSG_NUMBER	1 ('00000001')
BURST_TYPE	3 ('000011')
NUM_MSGS	1 ('00000001')
NUM_FIELDS	Greater than 0

- f. Upon receiving Data Burst Message at the mobile station, verify the following:
  1. The mobile station alerts the user for the incoming message and correctly displays the received message, when selected.

1  
2  
3  
4  
5  
6  
7  
8  
9  
10  
11  
12  
13  
14  
15  
16  
17  
18  
19  
20  
21  
22  
23  
24  
25  
26  
27  
28  
29  
30  
31  
32  
33  
34  
35  
36  
37  
38  
39  
40  
41  
42  
43  
44  
45  
46  
47  
48  
49  
50  
51  
52  
53  
54  
55  
56  
57  
58  
59  
60

2. The mobile station properly displays the picture, when selected.
3. The mobile station transmits a Data Burst Message to acknowledge the EMS message, indicating no error (i.e. contains a Cause Codes parameter having ERROR\_CLASS = '00').

**4.7.3.3.1.4 Minimum Standard**

---

The mobile station shall comply with step f.

**4.7.3.3.2 Base Station Test**

---

None.

## 4.7.4 Delivery of Formatted Text

---

### 4.7.4.1 Mobile Station Test

---

#### 4.7.4.1.1 Definition

---

This test verifies mobile station's ability to receive and properly display formatted text embedded in EMS messages (Information Element Identifier 0x0A), if supported.

#### 4.7.4.1.2 Traceability

---

(See. [1]);

4.3.7: *Wireless Enhanced Messaging Teleservice*

2.4.1.1.1.1: *Mobile SMS Message Termination*

#### 4.7.4.1.3 Method of Measurement

---

- a. Delete all outstanding short messages in the network for the mobile station. Delete all short messages in the mobile station.
- b. Create an EMS message in the Message Center for the mobile station. From the following text, include the text with formatting that is supported by the mobile station in the message:

Normal <b>Bold</b> <i>Italics</i> <b><i>Bold-Italics</i></b>
<u>Underlined</u> <b><u>Bold-Underlined</u></b> <b><i><u>Bold-Italics-Underlined</u></i></b>
Left-Justified
Center-Justified
Right-Justified

- c. Power on the mobile station and wait until it is in the *Mobile Station Idle State*.
- d. Instruct the network to send the EMS message to the mobile station.
- e. Ensure that the base station sends a *Data Burst Message* to the mobile station with the specified fields set as follows:

Field	Value
MSG_NUMBER	1 ('00000001')
BURST_TYPE	3 ('000011')
NUM_MSGS	1 ('00000001')
NUM_FIELDS	Greater than 0

- f. Upon receiving *Data Burst Message* at the mobile station, verify the following:
1. The mobile station alerts the user for the incoming message and correctly displays the received message, when selected.
  2. The mobile station properly displays the text, including correct formatting of the lines of text displayed.
  3. The mobile station transmits a *Data Burst Message* to acknowledge the EMS message, indicating no error (i.e. contains a Cause Codes parameter having ERROR\_CLASS = '00').

#### 4.7.4.1.4 Minimum Standard

---

The mobile station shall comply with step f.

#### 4.7.4.2 Base Station test

---

None.

## 4.8 Mobile Station Originated Enhanced Messaging Services [EMS] Tests:

---

This section is to be performed on mobile stations supporting mobile originated Enhanced Messaging Services [EMS]. The test cases below require the tester to verify that the Mobile Originated EMS messages constructed and sent by the mobile station under test contain the proper requisite components.

### 4.8.1 Concatenated Short Message EMS Message Delivery

---

#### 4.8.1.1 Mobile Station Test

---

##### 4.8.1.1.1 Definition

---

This test verifies mobile station's ability to compose and send Concatenated Short Message EMS messages.

##### 4.8.1.1.2 Traceability

---

**(See. [1]);**

4.3.7: *Wireless Enhanced Messaging Teleservice*

2.4.1.1.2: *Mobile Station Traffic Channel Procedures*

2.4.1.1.1.2: *Mobile SMS Message Origination*

**(See. [2]);**

9.2.3.24: *TP-User Data (TP-UD)*

##### 4.8.1.1.3 Method of Measurement

---

- a. Power on the mobile station and wait until it is in the Mobile station Idle State.
- b. Create an EMS message at the mobile station, consisting of multiple segments.
- c. Instruct the mobile station to send the all the segments of the EMS message to the Message Center.
- d. Verify that the mobile station sends all segments of the message.
- e. Ensure that the Message Center receives all segments of the message and sends the SMS acknowledgement to the mobile station for each segment.
- f. Verify the mobile station receives the SMS acknowledgements for each segment of the message.

1  
2  
3  
4  
5  
6  
7  
8  
9  
10  
11  
12  
13  
14  
15  
16  
17  
18  
19  
20  
21  
22  
23  
24  
25  
26  
27  
28  
29  
30  
31  
32  
33  
34  
35  
36  
37  
38  
39  
40  
41  
42  
43  
44  
45  
46  
47  
48  
49  
50  
51  
52  
53  
54  
55  
56  
57  
58  
59  
60

- g. If the EMS messages are sent over the dedicated channels, verify that upon sending the short message, the mobile station sends a Release Order to release the dedicated channels.

**4.8.1.1.4 Minimum Standard**

---

The mobile station shall comply with steps d f and g.

**4.8.1.2 Base Station Test**

---

None.

## 4.8.2 Delivery of Predefined EMS Information Elements

This section tests the mobile stations ability to send predefined information elements.

### 4.8.2.1 Delivery of Predefined Sound Elements

#### 4.8.2.1.1 Mobile Station Test

##### 4.8.2.1.1.1 Definition

This test verifies the mobile station's ability to compose and send messages containing predefined EMS sound elements, if supported.

##### 4.8.2.1.1.2 Traceability

(See. [1]);

4.3.7: *Wireless Enhanced Messaging Teleservice*

2.4.1.1.1.2: *Mobile SMS Message Origination*

(See. [2]):

9.2.3.24: *TP-User Data (TP-UD)*

##### 4.8.2.1.1.3 Method of Measurement

- a. Power on the mobile station and wait until it is in the *Mobile Station Idle State*.
- b. Create an EMS message at the mobile station. In the message include (1) one predefined sound.
- c. Instruct the mobile station to send the EMS message to the Message Center.
- d. Verify the mobile station sends a *Data Burst Message* to the base station with the fields set as follows:

Field	Value
MSG_NUMBER	1 ('00000001')
BURST_TYPE	3 ('000011')
NUM_MSGS	1 ('00000001')
NUM_FIELDS	Greater than 0

- e. Ensure that the Message Center receives *Data Burst Message* and sends the SMS acknowledgement to the mobile station.

1  
2  
3  
4  
5  
6  
7  
8  
9  
10  
11  
12  
13  
14  
15  
16  
17  
18  
19  
20  
21  
22  
23  
24  
25  
26  
27  
28  
29  
30  
31  
32  
33  
34  
35  
36  
37  
38  
39  
40  
41  
42  
43  
44  
45  
46  
47  
48  
49  
50  
51  
52  
53  
54  
55  
56  
57  
58  
59  
60

- f. Verify at the base station that the EMS message sent from the test mobile station contains (1) one predefined sound.

**4.8.2.1.1.4 Minimum Standard**

---

The mobile station shall comply with steps d and f.

## 4.8.2.2 Delivery of Predefined Animation Elements

---

### 4.8.2.2.1 Mobile Station Test

---

#### 4.8.2.2.1.1 Definition

---

This test verifies the mobile station's ability to compose and send messages containing predefined EMS animation elements (Information Element Identifier 0x0D), if supported.

#### 4.8.2.2.1.2 Traceability

---

**(See. [1]);**

4.3.7: *Wireless Enhanced Messaging Teleservice*

2.4.1.1.1.2: *Mobile SMS Message Origination*

**(See. [2]):**

9.2.3.24: *TP-User Data (TP-UD)*

#### 4.8.2.2.1.3 Method of Measurement

---

- a. Power on the mobile station and wait until it is in the *Mobile Station Idle State*.
- b. Create an EMS message at the mobile station. In the message include (1) one predefined animation object.
- c. Instruct the mobile station to send the EMS message to the Message Center.
- d. Verify the mobile station sends a *Data Burst Message* to the base station with the fields set as follows:

Field	Value
MSG_NUMBER	1 ('00000001')
BURST_TYPE	3 ('000011')
NUM_MSGS	1 ('00000001')
NUM_FIELDS	Greater than 0

- e. Ensure that the Message Center receives *Data Burst Message* and sends the SMS acknowledgement to the mobile station.

1  
2  
3  
4  
5  
6  
7  
8  
9  
10  
11  
12  
13  
14  
15  
16  
17  
18  
19  
20  
21  
22  
23  
24  
25  
26  
27  
28  
29  
30  
31  
32  
33  
34  
35  
36  
37  
38  
39  
40  
41  
42  
43  
44  
45  
46  
47  
48  
49  
50  
51  
52  
53  
54  
55  
56  
57  
58  
59  
60

- f. Verify at the base station that the EMS message sent from the test mobile station contains the predefined animation object.

**4.8.2.2.1.4 Minimum Standard**

---

The mobile station shall comply with steps d and f.

**4.8.2.2.2 Base Station Test**

---

None.

## 4.8.3 Delivery of User Defined EMS Information Elements

This section tests the mobile station's ability to send user defined information elements. To run these test cases it is assumed that user defined sound, animation and picture elements have been pre-stored in the phone, to be utilized in the test cases.

### 4.8.3.1 Delivery of User Defined Sound Elements

#### 4.8.3.1.1 Mobile Station Test

##### 4.8.3.1.1.1 Definition

This test verifies the mobile's ability to compose and send a message containing user defined (iMelody) EMS sound elements (Information Element Identifier 0x0C), if supported.

##### 4.8.3.1.1.2 Traceability

(See. [1]);

4.3.7: *Wireless Enhanced Messaging Teleservice*

2.4.1.1.1.2: *Mobile SMS Message Origination*

(See. [2]):

9.2.3.24: *TP-User Data (TP-UD)*

##### 4.8.3.1.1.3 Method of Measurement

- a. Power on the mobile station and wait until it is in the *Mobile Station Idle State*.
- b. Create an EMS message at the mobile station. In the message include (1) one user defined iMelody sound object.
- c. Instruct the mobile station to send the EMS message to the Message Center.
- d. Verify the mobile station sends a *Data Burst Message* to the base station with the fields set as follows:

Field	Value
MSG_NUMBER	1 ('00000001')
BURST_TYPE	3 ('000011')
NUM_MSGS	1 ('00000001')
NUM_FIELDS	Greater than 0

1  
2  
3  
4  
5  
6  
7  
8  
9  
10  
11  
12  
13  
14  
15  
16  
17  
18  
19  
20  
21  
22  
23  
24  
25  
26  
27  
28  
29  
30  
31  
32  
33  
34  
35  
36  
37  
38  
39  
40  
41  
42  
43  
44  
45  
46  
47  
48  
49  
50  
51  
52  
53  
54  
55  
56  
57  
58  
59  
60

- e. Ensure that the Message Center receives *Data Burst Message* and sends the SMS acknowledgement to the mobile station.
- f. Verify at the base station that the EMS message sent from the test mobile station contains the iMelody sound object sent.

**4.8.3.1.1.4 Minimum Standard**

---

The mobile station shall comply with steps d and f.

**4.8.3.1.2 Base Station Test**

---

None.

## 4.8.3.2 Delivery of User Defined Animation Elements

---

### 4.8.3.2.1 Mobile Station Test

---

#### 4.8.3.2.1.1 Definition

---

This test verifies mobile station's ability to compose and send a message containing user defined EMS animation elements (Information Element Identifier 0x0E or 0x0F), if supported.

#### 4.8.3.2.1.2 Traceability

---

(See. [1]);

4.3.7: *Wireless Enhanced Messaging Teleservice*

2.4.1.1.1.2: *Mobile SMS Message Origination*

(See. [2]):

9.2.3.24: *TP-User Data (TP-UD)*

#### 4.8.3.2.1.3 Method of Measurement

---

- a. Power on the mobile station and wait until it is in the *Mobile Station Idle State*.
- b. Create an EMS message at the mobile station. In the message include (1) one user defined animation object.
- c. Instruct the mobile station to send the EMS message to the Message Center.
- d. Verify the mobile station sends a *Data Burst Message* to the base station with the fields set as follows:

Field	Value
MSG_NUMBER	1 ('00000001')
BURST_TYPE	3 ('000011')
NUM_MSGS	1 ('00000001')
NUM_FIELDS	Greater than 0

- e. Ensure that the Message Center receives *Data Burst Message* and sends the SMS acknowledgement to the mobile station.

1  
2  
3  
4  
5  
6  
7  
8  
9  
10  
11  
12  
13  
14  
15  
16  
17  
18  
19  
20  
21  
22  
23  
24  
25  
26  
27  
28  
29  
30  
31  
32  
33  
34  
35  
36  
37  
38  
39  
40  
41  
42  
43  
44  
45  
46  
47  
48  
49  
50  
51  
52  
53  
54  
55  
56  
57  
58  
59  
60

- f. Verify at the base station that the EMS message sent from the test mobile station contains the animation object sent.

**4.8.3.2.1.4 Minimum Standard**

---

The mobile station shall comply with steps d and f.

**4.8.3.2.2 Base Station Test**

---

None.

### 4.8.3.3 Delivery of User Defined Picture Elements

---

#### 4.8.3.3.1 Mobile Station Test

---

##### 4.8.3.3.1.1 Definition

---

This test verifies mobile's ability to send user defined EMS picture elements (Information Element Identifier 0x10 or 0x11), if supported.

##### 4.8.3.3.1.2 Traceability

---

(See. [1]);

4.3.7: *Wireless Enhanced Messaging Teleservice*

2.4.1.1.2: *Mobile SMS Message Origination*

(See. [2]):

9.2.3.24: *TP-User Data (TP-UD)*

##### 4.8.3.3.1.3 Method of Measurement

---

- a. Power on the mobile station and wait until it is in the *Mobile Station Idle State*.
- b. Create an EMS message at the mobile station. In the message include (1) one user defined picture object.
- c. Instruct the mobile station to send the EMS message to the Message Center.
- d. Verify the mobile station sends a *Data Burst Message* to the base station with the fields set as follows:

Field	Value
MSG_NUMBER	1 ('00000001')
BURST_TYPE	3 ('000011')
NUM_MSGS	1 ('00000001')
NUM_FIELDS	Greater than 0

- e. Ensure that the Message Center receives *Data Burst Message* and sends the SMS acknowledgement to the mobile station.
- f. Verify at the base station that the EMS message sent from the test mobile station contains the picture object sent.

1  
2  
3  
4  
5  
6  
7  
8  
9  
10  
11  
12  
13  
14  
15  
16  
17  
18  
19  
20  
21  
22  
23  
24  
25  
26  
27  
28  
29  
30  
31  
32  
33  
34  
35  
36  
37  
38  
39  
40  
41  
42  
43  
44  
45  
46  
47  
48  
49  
50  
51  
52  
53  
54  
55  
56  
57  
58  
59  
60

**4.8.3.3.1.4 Minimum Standard**

---

The mobile station shall comply with steps d and f.

**4.8.3.4 Base Station Test**

---

None.

## 4.8.4 Delivery of Formatted Text

### 4.8.4.1 Mobile Station Test

#### 4.8.4.1.1 Definition

This test verifies mobile's ability to compose and send formatted text embedded in EMS messages (Information Element Identifier 0x0A), if supported.

#### 4.8.4.1.2 Traceability

(See. [1]);

4.3.7: *Wireless Enhanced Messaging Teleservice*

2.4.1.1.1.2: *Mobile SMS Message Origination*

#### 4.8.4.1.3 Method of Measurement

- a. Power on the mobile station and wait until it is in the *Mobile Station Idle State*.
- b. Create an EMS message in the mobile station under test. From the following text, include the text with formatting that is supported by the mobile station in the message:

Normal	<b>Bold</b>	<i>Italics</i>	<b><i>Bold-Italics</i></b>
<u>Underlined</u>	<b><u>Bold-Underlined</u></b>	<i><u>Bold-Italics-Underlined</u></i>	<b><i><u>Bold-Italics-Underlined</u></i></b>
Left-Justified			
	Center-Justified		
			Right-Justified

- c. Instruct the mobile station to send the EMS message to the Message Center.
- d. Verify the mobile station sends a Data Burst Message to the base station with the fields set as follows:

Field	Value
MSG_NUMBER	1 ('00000001')
BURST_TYPE	3 ('000011')

NUM_MSGS	1 ('00000001')
NUM_FIELDS	Greater than 0

- g. Ensure that the Message Center receives *Data Burst Message* and sends the SMS acknowledgement to the mobile station.
- h. Verify at the base station that the EMS message sent from the test mobile station contains the properly formatted text information.

#### 4.8.4.1.4 Minimum Standard

---

The mobile station shall comply with steps d and f.

#### 4.8.4.2 Base Station Test

---

None.