

3GPP2 C.S0036-0 v1.0

Publication Version

Date: March 11, 2002



3RD GENERATION  
PARTNERSHIP  
PROJECT 2  
"3GPP2"

---

*Recommended Minimum Performance Specification for  
C.S0022-0 Spread Spectrum Mobile Stations*

*Release 0*

*(Publication Version v1.0)*

**COPYRIGHT**

***3GPP2 and its Organizational Partners claim copyright in this document and individual Organizational Partners may copyright and issue documents or standards publications in individual Organizational Partner's name based on this document.***

***Requests for reproduction of this document should be directed to the 3GPP2 Secretariat at [secretariat@3gpp2.org](mailto:secretariat@3gpp2.org). Requests to reproduce individual Organizational Partner's documents should be directed to that Organizational Partner. See [www.3gpp2.org](http://www.3gpp2.org) for more information.***



## CONTENTS

1	1 INTRODUCTION.....	1-1
2	1.1 Scope .....	1-1
3	1.2 Terms and Definitions.....	1-2
4	1.3 General Test Procedures .....	1-9
5	1.4 Test Modes .....	1-9
6	1.5 Tolerances .....	1-10
7	1.5.1 CDMA System Parameter Tolerances .....	1-10
8	1.5.2 Measurement Tolerances.....	1-10
9	1.6 Measurement Data Evaluation .....	1-10
10	1.6.1 Evaluation of the Measurement Yield.....	1-12
11	1.6.2 Evaluation of the returned parameters .....	1-13
12	1.6.2.1 Evaluation with $\sigma_1$ , $\sigma_2$ Type Tests.....	1-13
13	1.6.2.1.1 Error Calculation.....	1-14
14	1.6.2.1.1.1 Calculation of Absolute Satellite Code Phase Error .....	1-15
15	1.6.2.1.1.2 Calculation of Relative Satellite Code Phase Error .....	1-16
16	1.6.2.1.1.3 Calculation of Pseudo Doppler Error .....	1-17
17	1.6.2.1.1.4 Calculation of Signal-to-Noise Ratio and Signal Strength Errors ..	1-17
18	1.6.2.1.1.5 Calculation of Pilot Phase Error .....	1-17
19	1.6.2.1.1.6 Calculation of Horizontal Position Error .....	1-18
20	1.6.2.2 Evaluation of the Returned RMS Error Estimates.....	1-18
21	2 GPS MINIMUM SPECIFICATIONS .....	2-1
22	2.1 GPS Performance Specifications .....	2-1
23	2.1.1 Stationary Location Tests .....	2-1
24	2.1.1.1 GPS Accuracy Test .....	2-1
25	2.1.1.1.1 Definition .....	2-1
26	2.1.1.1.2 Method of Measurement .....	2-2
27	2.1.1.1.3 Minimum Specification .....	2-2
28	2.1.1.2 GPS Dynamic Range Test .....	2-3
29	2.1.1.2.1 Definition .....	2-3
30	2.1.1.2.2 Method of Measurement .....	2-4
31	2.1.1.2.3 Minimum Specification .....	2-5

**CONTENTS**

1	2.1.1.3	GPS Sensitivity Test.....	2-5
2	2.1.1.3.1	Definition.....	2-5
3	2.1.1.3.2	Method of Measurement.....	2-6
4	2.1.1.3.3	Minimum Specification.....	2-6
5	2.1.1.4	GPS Multipath Accuracy Test.....	2-7
6	2.1.1.4.1	Definition.....	2-7
7	2.1.1.4.2	Method of Measurement.....	2-8
8	2.1.1.4.3	Minimum Specification.....	2-8
9	2.1.2	Moving Scenario Test.....	2-9
10	2.1.2.1	Moving Scenario GPS Accuracy Test.....	2-9
11	2.1.2.1.1	Definition.....	2-9
12	2.1.2.1.2	Method of Measurement.....	2-10
13	2.1.2.1.3	Minimum Specification.....	2-10
14	2.2	GPS Protocol Tests.....	2-11
15	2.2.1	GPS Position Location Session on the Paging Channel Test.....	2-11
16	2.2.1.1	Definition.....	2-11
17	2.2.1.2	Method of Measurement.....	2-11
18	2.2.1.3	Minimum Specification.....	2-12
19	2.2.2	Mobile Station Originated GPS Position Location Session Test.....	2-13
20	2.2.2.1	Mobile Station Originated GPS Position Location Session on the Access Channel.....	2-13
21	2.2.2.1.1	Definition.....	2-13
22	2.2.2.1.2	Method of Measurement.....	2-13
23	2.2.2.1.3	Minimum Specification.....	2-14
24	2.2.2.2	Mobile Station Originated GPS Position Location Session on a Dedicated Channel.....	2-14
25	2.2.2.2.1	Definition.....	2-14
26	2.2.2.2.2	Method of Measurement.....	2-14
27	2.2.2.2.3	Minimum Specification.....	2-15
28	3	AFLT MINIMUM SPECIFICATION.....	3-1
29	3.1	General Comments on AFLT Tests.....	3-1
30	3.2	AFLT Performance Specifications.....	3-2
31			
32			

**CONTENTS**

1	3.2.1	AFLT Accuracy Test.....	3-2
2	3.2.1.1	Definition.....	3-2
3	3.2.1.2	Method of Measurement.....	3-2
4	3.2.1.3	Minimum Specification.....	3-3
5	3.2.2	AFLT Sensitivity Test.....	3-4
6	3.2.2.1	Definition.....	3-4
7	3.2.2.2	Method of Measurement.....	3-4
8	3.2.2.3	Minimum Specification.....	3-5
9	3.3	AFLT Protocol Tests .....	3-5
10	3.3.1	AFLT Position Location Session on the Paging Channel Test.....	3-6
11	3.3.1.1	Definition.....	3-6
12	3.3.1.2	Method of Measurement.....	3-6
13	3.3.1.3	Minimum Specification.....	3-6
14	3.3.2	Mobile Station Originated AFLT Position Location Session Test.....	3-7
15	3.3.2.1	Mobile Station Originated AFLT Position Location Session on the Access Channel .....	3-7
16			
17	3.3.2.1.1	Definition.....	3-7
18	3.3.2.1.2	Method of Measurement.....	3-7
19	3.3.2.1.3	Minimum Specification.....	3-8
20	3.3.2.2	Mobile Station Originated Position AFLT Location Session on a Dedicated Channel .....	3-8
21			
22	3.3.2.2.1	Definition.....	3-8
23	3.3.2.2.2	Method of Measurement.....	3-8
24	3.3.2.2.3	Minimum Specification.....	3-9
25	4	HYBRID MINIMUM SPECIFICATIONS .....	4-1
26	4.1	General Comments on Hybrid Tests .....	4-1
27	4.2	Hybrid Performance Specifications .....	4-2
28	4.2.1	One Base Station + Three Satellites Hybrid Test.....	4-2
29	4.2.1.1	Definition.....	4-2
30	4.2.1.2	Method of Measurement.....	4-2
31	4.2.1.3	Minimum Specification.....	4-3
32	4.2.2	Two Base Stations + One Satellite Hybrid Test .....	4-3

**CONTENTS**

1	4.2.2.1	Definition .....	4-3
2	4.2.2.2	Method of Measurement.....	4-3
3	4.2.2.3	Minimum Specification .....	4-5
4	5	STANDARD TEST CONDITIONS .....	5-1
5	5.1	Standard Equipment .....	5-1
6	5.1.1	Basic Equipment .....	5-1
7	5.1.2	Associated Equipment .....	5-1
8	5.2	Standard Environmental Test Conditions.....	5-1
9	5.3	Standard Conditions for the Primary Power Supply .....	5-1
10	5.3.1	General Requirements .....	5-1
11	5.3.2	Standard DC Test Voltage from Accumulator Batteries .....	5-1
12	5.3.3	Standard AC Voltage and Frequency .....	5-2
13	5.4	Standard CDMA Test Equipment .....	5-2
14	5.4.1	Base Station Simulator Equipment .....	5-2
15	5.4.1.1	Transmitter Equipment.....	5-2
16	5.4.1.2	Receiver Equipment .....	5-3
17	5.4.1.3	Protocol Support.....	5-3
18	5.4.1.4	Timing Signals.....	5-3
19	5.4.1.5	Base Station <i>Data Burst Message</i> Transport Capability .....	5-3
20	5.4.2	Synchronization of Base Stations .....	5-4
21	5.4.3	CDMA Pilot Generator Equipment .....	5-5
22	5.4.3.1	Transmit Equipment.....	5-5
23	5.4.3.2	Timing Signals.....	5-5
24	5.4.3.3	Synchronization of a CDMA Pilot Generator.....	5-5
25	5.5	GPS Simulator Equipment.....	5-5
26	5.6	Synchronization of the Serving Base Station and the GPS Simulator .....	5-6
27	5.7	AWGN Generator Equipment .....	5-7
28	5.8	PDE Simulator Equipment .....	5-8
29	5.8.1	PDE Simulator Responses.....	5-9
30	5.8.2	<i>Position Determination Data Message</i> Call Flows.....	5-9
31	5.9	Functional System Set-ups.....	5-13

## CONTENTS

1	5.9.1	Functional Block Diagrams .....	5-13
2	5.9.2	General Comments .....	5-17
3	Annex A – METHOD OF GENERATING PDE SIMULATOR RESPONSES .....		A-1
4	A.1	General Requirements for <i>Position Determination Data Message</i> Origination.....	A-1
5	A.1.1	<i>Data Burst Message</i> Origination.....	A-1
6	A.1.2	<i>Position Determination Data Message</i> Origination.....	A-1
7	A.1.3	<i>Position Determination Data Message</i> Segmentation .....	A-4
8	A.2	Method of Selecting the PDE Simulator Response Message .....	A-4
9	A.2.1	PDE Simulator Response Type.....	A-4
10	A.2.2	PDE Simulator Response Reference Time.....	A-5
11	A.3	Method of Determining the PDE Simulator Response Values.....	A-7
12	A.3.1	Setting of PDE Simulator Response Field Counters .....	A-7
13	A.3.2	Calculating of PDE Simulator Numerical Parameter Values .....	A-9
14	A.3.3	Setting of PDE Simulator Response Information Parameters.....	A-9
15	A.3.4	Setting of PDE Simulator Request Information Parameters.....	A-10
16	Annex B – REFERENCE GPS NAVIGATION DATA, SYSTEM TIME AND USER LOCATION ...		
17	.....		B-1
18	B.1	Reference Location.....	B-1
19	B.2	Reference Time .....	B-1
20	B.3	Reference Ephemeris .....	B-1
21	B.4	Reference Almanac .....	B-6
22	B.5	List of Active Satellites .....	B-13
23	B.6	Simulated Base Station Locations .....	B-14
24	B.7	Simulated Mobile Station Locations.....	B-14
25	B.8	Additional GPS Simulator Settings .....	B-15
26	Annex C – METHOD OF STATISTICAL CONFIDENCE DETERMINATION.....		C-1
27	C.1	Description of the Confidence Determination Method.....	C-1
28	C.2	Evaluation Example.....	C-2
29	Annex D PDE SIMULATOR RESPONSE MESSAGES.....		D-1
30			

**FIGURES**

1 Figure 5.8.2-1 Example Successful Call Flow for Test Modes 1 and 2..... 5-11  
2 Figure 5.8.2-2 Example Successful Call Flow for Test Modes 3 and 4, with Mobile Station  
3 that is Capable of Location Calculation ..... 5-12  
4 Figure 5.8.2-3 Example Successful Call Flow for Test Modes 3 and 4, with Mobile Station  
5 that is not Capable of Location Calculation ..... 5-13  
6 Figure 5.9.1-1 Functional Set-up for GPS Tests..... 5-14  
7 Figure 5.9.1-2 Functional Set-up for AFLT Tests ..... 5-15  
8 Figure 5.9.1-3 Functional Set-up for Hybrid Tests ..... 5-16  
9

**TABLES**

1	Table 1.6-1 Summary of Test Evaluation Parameters .....	1-11
2	Table 1.6.2.1.1-1 Returned Parameter Fields and Corresponding Error Indications.....	1-15
3	Table 1.6.2.2-1 Returned RMS Error Estimate Parameter Fields and Corresponding Error	
4	Indications .....	1-19
5	Table 2.1.1.1.2-1 Satellite Signal Levels for the GPS Accuracy Test .....	2-2
6	Table 2.1.1.1.3-1 Minimum Specifications for the GPS Accuracy Test.....	2-3
7	Table 2.1.1.2.2-1 Satellite Signal Levels for the GPS Dynamic Range Test.....	2-4
8	Table 2.1.1.2.3-1 Minimum Specifications for the GPS Dynamic Range Test.....	2-5
9	Table 2.1.1.3.2-1 Satellite Signal Levels for the GPS Sensitivity Test .....	2-6
10	Table 2.1.1.3.3-1 Minimum Specifications for the GPS Sensitivity Test.....	2-7
11	Table 2.1.1.4.2-1 Satellite Signal Levels for the GPS Multipath Accuracy Test.....	2-8
12	Table 2.1.1.4.3-1 Minimum Specifications for the GPS Multipath Accuracy Test.....	2-9
13	Table 2.1.2.1.2-1 Satellite Signal Levels for the Moving Scenario GPS Accuracy Test.....	2-10
14	Table 2.1.2.1.3-1 Minimum Specifications for the Moving Scenario GPS Accuracy Test..	2-11
15	Table 2.2.1.2-1 Satellite Signal Levels for the Protocol Tests.....	2-12
16	Table 2.2.1.3-1 Minimum Specifications for the GPS Position Location Session on the	
17	Paging Channel Test .....	2-13
18	Table 2.2.2.1.3-1 Minimum Specifications for the Mobile Station Originated GPS Position	
19	Location Session Tests .....	2-14
20	Table 3.2.1.2-1 Signal Levels for the AFLT Accuracy Test.....	3-2
21	Table 3.2.1.3-1 Minimum Specifications for the AFLT Accuracy Test .....	3-3
22	Table 3.2.2.2-1 Signal Levels for the AFLT Sensitivity Test .....	3-4
23	Table 3.2.2.3-1 Minimum Specifications for the AFLT Sensitivity Test .....	3-5
24	Table 3.3.1.2-1 Signal Levels for the AFLT Protocol Tests .....	3-6
25	Table 3.3.1.3-1 Minimum Specifications for the AFLT Position Location Session on the	
26	Paging Channel Test .....	3-7
27	Table 3.3.2.1.3-1 Minimum Specifications for the Mobile Station Originated AFLT Position	
28	Location Session Tests .....	3-8
29	Table 4.2.1.2-1 Satellite Signal Levels for the One Base Station + Three Satellites Hybrid	
30	Test .....	4-2
31	Table 4.2.1.3-1 Minimum Specifications for the One Base Station + Three Satellites Hybrid	
32	Test .....	4-3
33	Table 4.2.2.2-1 Base Station Signal Levels for the Two Base Stations + One Satellite Hybrid	
34	Test .....	4-4

## TABLES

1	Table 4.2.2.2-2 Satellite Signal Level for the Two Base Stations + One Satellite Hybrid Test..	
2	.....	4-4
3	Table 4.2.2.3-1 Minimum Specifications for the Two Base Stations + One Satellite Hybrid	
4	Test .....	4-5
5	Table 5.7-1 AWGN Generator Frequency Ranges .....	5-8
6	Table 5.9.2-1 Special Field Values of the <i>System Parameters Message</i> .....	5-18
7	Table 5.9.2-2 Special Field Value of the <i>Extended System Parameters Message</i> .....	5-18
8	Table 5.9.2-3 Special Field Values of the <i>Access Parameters Message</i> .....	5-18
9	Table 5.9.2-4 Special Field Values of the <i>General Neighbor List Message</i> for the Serving Base	
10	Station .....	5-19
11	Table 5.9.2-5 Time Limit and Constant Values .....	5-20
12	Table A.1.2-1 <i>Position Determination Data Message</i> Format for Test Modes 1 and 2.....	A-1
13	Table A.1.2-2 <i>Position Determination Data Message</i> Format for Test Modes 3 and 4, with a	
14	Mobile Station that is Capable of Position Calculation .....	A-2
15	Table A.1.2-3 <i>Position Determination Data Message</i> Format for Test Modes 3 and 4, with a	
16	Mobile Station that is not Capable of Position Calculation.....	A-3
17	Table A.2.1-1 PDE Simulator Response Types .....	A-4
18	Table A.2.2-1 PDE Simulator Response Reference Time Information .....	A-6
19	Table A.3.1-1 PDE Simulator Response Field Counter Settings .....	A-8
20	Table A.3.3-1 PDE Simulator Response Information Parameters .....	A-10
21	Table A.3.4-1 PDE Simulator Request Information Parameters .....	A-11
22	Table B.8-1 GPS Simulator Settings.....	B-16
23	Table C.1-1 Identification of Location Error Samples for Comparison with FCC Required	
24	Thresholds of 67% and 95% (at the 90% Confidence Level) .....	C-2
25	Table D-1 Pilot PN Offset and BASE_ID Assignment Used in the PDE Simulator Response	
26	Messages .....	D-1

27

**NOTES**

- 1 1. This Specification uses the following verbal forms: “Shall” and “shall not” identify  
2 requirements to be followed strictly to conform to the Specification and from which  
3 no deviation is permitted. “Should” and “should not” indicate that one of several  
4 possibilities is recommended as being particularly suitable, without mentioning or  
5 excluding others; that a certain course of action is preferred but not necessarily  
6 required; or that (in the negative form) a certain possibility or course of action is  
7 discouraged but not prohibited. “May” and “need not” indicate a course of action  
8 permissible within the limits of the Specification. “Can” and “cannot” are used for  
9 statements of possibility and capability, whether material, physical, or causal.
- 10 2. There are four Annexes in this Specification. Annexes A, B, C and D are normative  
11 and are considered part of this Specification. Annex D contains a data file  
12 attachment that is normative and is considered part of this Specification.
- 13 3. The terms “location” and “position” are used interchangeably throughout this  
14 document. In this respect the definition of the term differs from the historic use of  
15 location in wireless systems to identify the mobile’s current serving system.
- 16 4. Those wishing to deploy systems compliant with this Specification should also be  
17 compliant with Parts 15, 22, 24, and 27 of [18] and with the applicable rules and  
18 regulations of local administrations.
- 19 5. Those wishing to deploy systems in the United States should also take notice of the  
20 requirement to be compliant with Federal Communications Commission (FCC)  
21 Rulings on 911 Emergency Services. Meeting the requirements contained in this  
22 Specification does not guarantee compliance with the FCC requirements listed in  
23 [19].
- 24 6. The operation and messages specified in [1] apply to what is usually known as  
25 handset-based position location method. The testing of network-based methods is  
26 beyond the scope of this Specification.
- 27 7. Footnotes appear at various points in this Specification to elaborate and to further  
28 clarify items discussed in the body of the Specification.
- 29 8. Unless indicated otherwise, this document presents numbers in decimal form.  
30 Binary numbers are distinguished in the text by the use of single quotation marks.
- 31 9. The following operators define mathematical operations:  
32  $\times$  indicates multiplication.  
33  $/$  indicates division.  
34  $+$  indicates addition.  
35  $-$  indicates subtraction.  
36  $*$  indicates complex conjugation.  
37  $\in$  indicates a member of the set.  
38  $\lfloor x \rfloor$  indicates the largest integer less than or equal to  $x$ :  $\lfloor 1.1 \rfloor = 1$ ,  $\lfloor 1.0 \rfloor = 1$ .  
39  $\lceil x \rceil$  indicates the smallest integer greater or equal to  $x$ :  $\lceil 1.1 \rceil = 2$ ,  $\lceil 2.0 \rceil = 2$ .

**FOREWORD**

1         $|x|$  indicates the absolute value of  $x$ :  $|-17|=17$ ,  $|17|=17$ .

2         $\oplus$  indicates exclusive OR (modulo-2 addition).

3         $\min(x, y)$  indicates the minimum of  $x$  and  $y$ .

4         $\max(x, y)$  indicates the maximum of  $x$  and  $y$ .

5         $x \bmod y$  indicates the remainder after dividing  $x$  by  $y$ :  $x \bmod y = x - (y \times \lfloor x/y \rfloor)$ .

6         $\text{Re}\{x\}$  indicates the real part of  $x$ .

7         $\text{Im}\{x\}$  indicates the imaginary part of  $x$ .

- 8        9. This Specification supports testing of mobile stations compliant with [1].
- 9        10. This Specification supports testing of mobile stations that meet the minimum  
10        specifications specified in [5].
- 11       11. This Specification tests only the position location functionality of a mobile station.  
12       Testing interoperation with other services, such as voice, data or SMS, is beyond the  
13       scope of this document.
- 14       12. This Specification does not support testing mobile station cold start time to first fix  
15       requirements.
- 16       13. References in this document are to TIA/EIA-95-B. This Specification is equally  
17       applicable to TIA/EIA/IS-2000 and TIA/EIA/IS-2000-A. Except where explicit  
18       references are made to TIA/EIA/IS-2000, the reference to TIA/EIA-95-B can be  
19       converted directly to TIA/EIA/IS-2000 and TIA/EIA/IS-2000-A usage.
- 20       14. The terms “base station” and “base station simulator” are used interchangeably  
21       throughout this document, reflecting the fact that either type of equipment may be  
22       used as long as all test equipment requirements given in this Specification are  
23       satisfied.
- 24       15. Some tests in this revision specify using a physical CDMA channel that is not  
25       mandatory for IS-2000-A mobile stations. If the mobile station does not support a  
26       specified physical channel, then the equivalent IS-2000-A-only physical channel  
27       should be used instead. Specifically, the Broadcast Control Channel and Forward  
28       Command Control Channel should be used in place of the Paging Channel, the  
29       Enhanced Access Channel should be used in place of the Access Channel, and the  
30       Dedicated Control Channel should be used in place of the Traffic (Fundamental)  
31       channel.
- 32       16. For the test parameter tables,  $\bar{I}_0$  is specified in terms of power spectral density in a  
33       Spreading Rate 1 bandwidth. For testing applicable to Spreading Rate 3, the total  
34       received power in a Spreading Rate 3 bandwidth is effectively 5 dB higher.
- 35       17. Wherever this document refers to CDMA System time in frames, it is taken to mean  
36       an integer value  $T$  such that:  $T = \lfloor t/0.02 \rfloor$ , where  $t$  represents System Time in  
37       seconds.

**NOTES**

- 1 18. The tests will be performed using modulated L1 carriers; however, the specification  
2 of the signal levels is based upon an unmodulated L1 carrier, referenced to the  
3 mobile station antenna input.

4

## **REFERENCES**

1 The following Specifications contain provisions that, through reference in this text,  
2 constitute provisions of this Specification. At the time of publication, the editions indicated  
3 were valid. All Specifications are subject to revision, and parties to agreements based on  
4 this Specification are encouraged to investigate the possibility of applying the most recent  
5 editions of the Specifications indicated below. ANSI and TIA maintain registers of currently  
6 valid national Standards published by them.

7

8

**REFERENCES**

- 1 1. 3GPP2 C.S0022-0 v3.0, *Position Determination Service Standard for Dual-Mode Spread*  
2 *Spectrum Systems*, March 2001.
- 3 2. J-STD-036, *Enhanced Wireless 9-1-1 Phase 2*, June 2000.
- 4 3. TSB-100, *Wireless Network Reference Model*, July 1988.
- 5 4. 3GPP2 C.S0010-A v2.0, *Recommended Minimum Performance Standards for cdma2000*  
6 *Spread Spectrum Base Stations*, April 2001.
- 7 5. 3GPP2 C.S0011-A v2.0, *Recommended Minimum Performance Standard for cdma2000*  
8 *Spread Spectrum Mobile Stations*, April 2001.
- 9 6. EIA/IS-19-B, *Recommended Minimum Standards for 800-MHz Cellular Subscriber Units*,  
10 June 1988.
- 11 7. TIA/EIA/IS-95-B, *Mobile Station-Base Station Compatibility Standard for Dual-Mode*  
12 *Spread Spectrum Systems*, March 1999.
- 13 8. C.S0002-A-2, *Physical Layer Standard for cdma2000 Spread Spectrum Systems*,  
14 February 2002.
- 15 9. C.S0004-A-2, *Signaling Link Access Control (LAC) Standard for cdma2000 Spread*  
16 *Spectrum Systems*, February 2002.
- 17 10. C.S0005-A-2, *Upper Layer (Layer 3) Signaling Standard for cdma2000 Spread Spectrum*  
18 *Systems*, February 2002.
- 19 11. TIA/EIA/IS-2000.6-A-2, *Analog Signaling Standard for cdma2000 Spread Spectrum*  
20 *Systems*, July 1999.
- 21 12. C.R1001-C v1.0, *Administration of Parameter Value Assignments for TIA/EIA Spread*  
22 *Spectrum Standards*, January 2002.
- 23 13. 3GPP2 C.S0026-0 v2.0, *Test Data Service Option (TDSO) for cdma2000 Spread Spectrum*  
24 *Systems*, March 2001.
- 25 14. 3GPP2 C.S0025-0 v2.0, *Markov Service Option (MSO) for cdma2000 Spread Spectrum*  
26 *Systems*, March 2001.
- 27 15. 3GPP2 C.S0013-A v1.0, *Loopback Service Options (LSO) for cdma2000 Spread Spectrum*  
28 *Systems*, November 2000.
- 29 16. ICD-GPS-200C, *Navstar GPS Space Segment / Navigation User Interface*, September  
30 1997.
- 31 17. DMA TR 8350.2, *Defense Mapping Agency Publication*, September 1987.
- 32 18. CFR Title 47, *Code of Federal Regulations*, October 1999.
- 33 19. FCC 00-326, CC Docket No. 94-102, *Fourth Memorandum Opinion and Order in the*  
34 *Matter of Revision of the Commission's Rules to Ensure Compatibility with Enhanced 911*  
35 *Emergency Calling Systems*, September 2000.
- 36 20. FCC OET Bulletin No. 71, *Guidelines for Testing and Verifying the Accuracy of Wireless*  
37 *E911 Location Systems*, April 2000.

**REFERENCES**

- 1 21. GPS Navstar, *Global Positioning System Standard Positioning Service Signal Specification*,
- 2 June 1995.
- 3

1   **1   INTRODUCTION**

2   **1.1   Scope**

3   This Specification details definitions, methods of measurement, and minimum performance  
4   characteristics for Position Location Capable Code Division Multiple Access (CDMA) mobile  
5   stations. This Specification shares the purpose of [1] (and subsequent revisions thereof) by  
6   ensuring that a mobile station's location can be determined in any wireless system that  
7   meets the compatibility requirements of [1].

8   Test methods are recommended in this document; however, methods other than those  
9   recommended may suffice for the same purpose.

10

11

1 **1.2 Terms and Definitions**

2 **2D Fix.** A two-dimensional (latitude and longitude) position determination process.

3 **3D Fix.** A three-dimensional (latitude, longitude and height) position determination  
4 process.

5 **Access Channel.** A Reverse CDMA Channel used by mobile stations for communicating to  
6 the base station. The Access Channel is used for short signaling message exchanges, such  
7 as call originations, responses to pages, and registrations. The Access Channel is a slotted  
8 random access channel.

9 **Advanced Forward Link Trilateration (AFLT).** A geolocation technique that utilizes the  
10 mobile station's measured time-difference-of-arrival of radio signals from the base stations  
11 (and, possibly, other terrestrial measurements).

12 **AFLT.** See Advanced Forward Link Trilateration.

13 **Almanac.** See GPS Almanac.

14 **Alpha.** See Alpha, Beta Parameters.

15 **Alpha, Beta Parameters.** Ionospheric parameters, which allow the "L1 only" user to utilize  
16 the ionospheric model for computation of the ionospheric delay. Alpha and Beta  
17 parameters are contained in page 18 of subframe 4 of the GPS navigation message frame.

18 **Assistance Data.** The assistance data provided by the base station to the mobile station for  
19 various purposes (for example, acquisition, location calculation or sensitivity improvement).

20 **Authentication.** An algorithmic exchange procedure used by a base station to validate a  
21 mobile station's identity.

22 **Autonomous Mobile Station.** A mobile station that is capable of autonomously  
23 determining its own position without any help from the base station.

24 **Autonomous Base Station.** A base station capable of determining the location of the  
25 mobile station without requiring any cooperation from the mobile station.

26 **Azimuth.** An angle that specifies a direction in the horizontal plane, expressed in degrees  
27 measured clockwise from True North.

28 **AWGN.** Additive White Gaussian Noise.

29 **Bad Satellite.** A bad satellite is one that is unusable for position calculation. See Satellite  
30 Health.

31 **Band Class.** A set of frequency channels and a numbering scheme for these channels.

32 **Base Station.** The base station includes the transceiver equipment, Mobile Switching  
33 Center (MSC), Mobile Positioning Center (MPC), Position Determination Entity (PDE) and  
34 any Inter-Working Function (IWF) required for network connection.

35 **Base Station Almanac.** The location coordinates and reference time correction parameters  
36 for a collection of base stations in the immediate neighborhood of the mobile station (the  
37 size of the immediate neighborhood is a service provider option).

- 1 **Beta.** See Alpha, Beta Parameters.
- 2 **bps.** Bits-per-second.
- 3 **C/A Code.** Coarse/Acquisition code used for spectral spreading of the GPS signal.
- 4 **C/A Code Chip.** The interval defined by the chipping (spreading) rate of the GPS C/A code.  
5 Stated as a time interval, one chip equals approximately 977.5 ns; as a distance it is  
6 approximately 293.0 m.
- 7 **C/N<sub>0</sub>.** The ratio of the unmodulated carrier signal power (C) to the power spectral density of  
8 background noise (N<sub>0</sub>).
- 9 **CDMA.** See Code Division Multiple Access.
- 10 **CDMA Channel.** The set of channels transmitted between the base station and the mobile  
11 station within a given CDMA frequency assignment.
- 12 **CDMA Code Boundary.** The point in time where the system time modulo the PN code  
13 period is precisely zero.
- 14 **CDMA System Time.** All base station digital transmissions are referenced to a common  
15 CDMA system-wide time scale that uses the Global Positioning System (GPS) time scale,  
16 which is traceable to and synchronous with Universal Coordinated Time (UTC). GPS and  
17 UTC differ by an integer number of seconds, specifically the number of leap second  
18 corrections added to UTC since January 6, 1980. The start of CDMA System Time is  
19 January 6, 1980 00:00:00 UTC, which coincides with the start of GPS time. (See  
20 TIA/EIA/95-B Section 1.2). Note that if the CDMA baseband transmit signal is modeled as  
21 a complex impulse train passed through a symmetric non-causal filter, then the precise  
22 zero instant of system time modulo the pilot PN sequence code period is given by the  
23 midpoint between the impulse representing the last element of the pilot PN sequence and  
24 the subsequent impulse representing the first element of the pilot PN sequence. The  
25 impulse train represents the pilot PN sequence, where the impulses are separated by  
26 exactly one PN code chip. The symmetric non-causal filter represents the baseband filter  
27 shape prior to the pre-equalization filter.
- 28 **Code Channel.** A subchannel of a Forward CDMA Channel or Reverse CDMA Channel.  
29 Each subchannel uses an orthogonal Walsh function or quasi-orthogonal function.
- 30 **Code Division Multiple Access (CDMA).** A technique for spread-spectrum multiple-access  
31 digital communications that creates channels through the use of unique code sequences.
- 32 **Code Phase.** At a given time, the code phase is the fraction of the code period that has  
33 elapsed since the latest code boundary (GPS or CDMA).
- 34 **Code Phase Search Window.** The expected range of possible code phase values.
- 35 **dBm.** A measure of power expressed in terms of its ratio (in dB) to one milliwatt.
- 36 **dBm/Hz.** A measure of power spectral density. The ratio, dBm/Hz, is the power in one  
37 Hertz of bandwidth, where power is expressed in units of dBm.
- 38 **dBW.** A measure of power expressed in terms of its ratio (in dB) to one watt.
- 39 **DGPS.** Differential GPS.

1 **Dilution of Precision.** A measure of position determination accuracy that is solely a  
 2 function of the geometrical layout of the reference points used in the position  
 3 determination, as seen from the estimated position (for GPS, position of the satellites  
 4 relative to the receiver antenna). One-sigma position error is approximately the product of  
 5 the value of the Dilution of Precision and the one-sigma error in measured range from the  
 6 mobile station to the reference points.

7 **DOP.** See Dilution of Precision.

8 **Doppler  $n^{\text{th}}$  Order.** The  $n^{\text{th}}$  order moment specifying a satellite's observed Doppler.

9 **Doppler Search Window.** The expected range of possible Doppler values.

10  **$E_b$ .** Average energy of an information bit at the mobile station antenna input.

11  $\frac{E_b}{N_t}$ . The ratio in dB of the combined received energy per bit to the effective noise power  
 12 spectral density at the mobile station antenna input.

13  **$E_c$ .** Average energy accumulated over one PN chip period.

14  $\frac{E_c}{I_{\text{or}}}$ . The ratio in dB between the energy accumulated over one PN chip period ( $E_c$ ) to the  
 15 total transmit power spectral density.

16 **ECEF.** "Earth-Centered-Earth-Fixed". A frame of reference for specifying positions that is  
 17 centered in the center of the Earth and rotates with it.

18 **Elevation Angle.** The angle between a (GPS) satellite and the horizon, expressed in  
 19 degrees.

20 **Ephemeris.** The precise (high accuracy) orbital parameters of one GPS satellite, as  
 21 transmitted by that satellite in GPS subframes 2 and 3.

22 **Extended Base Station Almanac.** The location coordinates and reference time correction  
 23 parameters for a collection of base stations in the extended neighborhood of the mobile  
 24 station (the size of the extended neighborhood is a service provider option).

25 **Fix.** The process of performing position computation.

26 **Forward Traffic Channel.** One or more code channels used to transport user and  
 27 signaling traffic from the base station to the mobile station.

28 **Frame.** See GPS Navigation Message Frame.

29 **Geolocation.** The process of determining a geographic location.

30 **GHz.** Gigahertz ( $10^9$  Hertz).

31 **GPS.** Global Positioning System.

32 **GPS Almanac.** The almanac data are a reduced-precision subset of the clock and  
 33 ephemeris parameters for all satellites, as transmitted by every satellite in GPS subframes 4  
 34 and 5.

1 **GPS Code Boundary.** The point in time where the system time modulo the C/A code period  
2 is precisely zero.

3 **GPS Navigation Message Frame.** A GPS navigation message frame contains five  
4 subframes. Subframes 1 through 3 contain ephemeris and clock parameters; subframes 4  
5 and 5 contain message and almanac parameters.

6 **GPS Navigation Message Subframe.** One of the five GPS subframes of the GPS navigation  
7 message. The subframe is 300-bits long.

8 **GPS Navigation Message Superframe.** A GPS navigation message superframe consists of  
9 25 frames and has a duration of 12.5 minutes.

10 **Handset-based Position Location.** A position location method, where the underlying,  
11 fundamental measurements to be used in the location calculation are made at the mobile  
12 station. The location calculation itself can be performed by either the mobile station or by  
13 one or more network entities. See also Network-based Position Location.

14 **ICD.** Interface Control Document.

15  **$I_{oc}$ .** The power spectral density of a band-limited white noise source, simulating  
16 interference from other cells or other channel interference or both, as measured at the  
17 mobile station antenna input. See also OCNS.

18  **$I_{or}$ .** The total transmit power spectral density of the Forward CDMA Channel at the base  
19 station antenna output.

20  **$\hat{I}_{or}$ .** The received power spectral density of the Forward CDMA Channel as measured at the  
21 mobile station antenna input.

22 **IWF.** InterWorking Function. A network entity enabling interactions between network  
23 elements, such as interactions between an MSC and a landline function. The IWF usually  
24 performs protocol conversions as its primary function.

25 **kHz.** Kilohertz ( $10^3$  Hertz).

26 **Legacy Terminal.** A mobile station that does not support the position determination  
27 techniques described in Reference [1].

28 **Location.** The terms “location” and “position” are used interchangeably throughout this  
29 document. In this respect, the definition of the term differs from the historic use of location  
30 in wireless systems to identify the mobile’s current serving system. See Position.

31 **LSB.** Least Significant Bit.

32 **Mean Input Power.** The total received calorimetric power measured in a specified  
33 bandwidth at the antenna input, including all internal and external signal and noise  
34 sources.

35 **Mean Output Power.** The total transmitted calorimetric power measured in a specified  
36 bandwidth at the antenna output when the transmitter is active.

37 **MHz.** Megahertz ( $10^6$  Hertz).

38 **MPC.** Mobile Positioning Center: The network entity that serves as the point of interface  
39 of the wireless network for the exchange of geographic position information.

- 1 **Mobile Station (MS).** A station that communicates with the base station.
- 2 **Mobile Station Originated Message.** A message originating from a mobile station.
- 3 **Mobile Station Terminated Message.** A message received by a mobile station.
- 4 **Mobile Switching Center (MSC).** A configuration of equipment that provides cellular  
5 radio-telephone service. Also called the Mobile Telephone Switching Office (MTSO).
- 6 **ms.** Millisecond ( $10^{-3}$  second).
- 7 **MS.** See Mobile Station.
- 8 **MSB.** Most Significant Bit.
- 9 **MSC.** See Mobile Switching Center.
- 10 **Navigation Message Bits.** The message bits (50 bits-per-second) transmitted by GPS  
11 satellites, containing the satellite clock, ephemeris, almanac and other parameters.
- 12  **$N_0$ .** The effective inband noise or interference power spectral density.
- 13  **$N_t$ .** The effective noise power spectral density at the mobile station antenna input.
- 14 **N/A.** Not applicable.
- 15 **Network-based Position Location.** A position location method, where the underlying,  
16 fundamental measurements to be used in the location calculation are made by the  
17 terrestrial network, typically by one or more base stations. See also Handset-based Position  
18 Location.
- 19 **ns.** Nanosecond ( $10^{-9}$  second).
- 20 **N/S.** Not specified.
- 21 **OCNS.** See Orthogonal Channel Noise Simulator.
- 22 **OCNS  $E_c$ .** Average energy per PN chip for the OCNS.
- 23  **$\frac{\text{OCNS } E_c}{I_{or}}$ .** The ratio of the average transmit energy per PN chip for the OCNS to the total  
24 transmit power spectral density.
- 25 **Orthogonal Channel Noise Simulator.** A hardware mechanism used to simulate the users  
26 on the other orthogonal channels of a Forward CDMA Channel.
- 27 **Paging Channel (PCH).** A code channel in a Forward CDMA Channel used for transmission  
28 of control information and pages from a base station to a mobile station.
- 29 **PDE.** See Position Determination Entity.
- 30 **Pilot Channel.** An unmodulated, direct-sequence spread spectrum signal transmitted by a  
31 CDMA base station or mobile station. A pilot channel provides a phase reference for  
32 coherent demodulation and may provide a means for signal strength comparisons between  
33 base stations for determining when to handoff.
- 34 **Pilot  $E_c$ .** Average energy per PN chip for the Pilot Channel.

1  $\frac{\text{Pilot } E_c}{I_o}$ . The ratio of the received pilot energy per chip,  $E_c$ , to the total received power  
2 spectral density (noise and signals).

3  $\frac{\text{Pilot } E_c}{I_{or}}$ . The ratio of the transmit pilot energy per chip,  $E_c$ , to the total transmit power  
4 spectral density.

5 **Pilot Phase Offset.** The time difference measured at the mobile station between the  
6 earliest arriving useable multipath component of a pilot and the mobile station system time  
7 reference. The AFLT technique is based primarily on Pilot Phase Offset data.

8 **Pilot PN Sequence.** A pair of modified maximal length PN sequences used to spread the  
9 Forward CDMA Channel and the Reverse CDMA Channel. Different base stations are  
10 identified by different pilot PN sequence offsets.

11 **PN.** Pseudonoise.

12 **PN Chip.** One bit in the PN sequence.

13 **PN Offset.** The PN offset measured in units of 64 PN chips of a pilot, relative to the zero-  
14 offset pilot PN sequence.

15 **PN Sequence.** Pseudonoise sequence. A periodic binary sequence.

16 **Position.** The geographic position of the mobile station expressed in latitude and longitude  
17 and height.

18 **Position Determination Entity (PDE).** A network entity that manages the position or  
19 geographic location determination of the mobile station.

20 **ppb.** Parts-per-billion.

21 **Pseudodoppler.** The measured Doppler frequency shift in the signal received from the GPS  
22 satellite. Since the satellite and receiver clock drifts are included, it is referred to as  
23 pseudodoppler.

24 **Pseudorange.** The measured range (in GPS chips) from the observed satellite to the GPS  
25 receiver antenna. Since the satellite and receiver clock biases are included, it is referred to  
26 as pseudorange.

27 **Push.** An unsolicited response.

28 **PRN Number.** The GPS PRN signal number as defined in ICD-GPS-200C, table 3-I.

29 **Reference Bit Boundary.** A boundary between two 20-ms GPS bit intervals chosen as the  
30 reference point for code phases.

31 **Reverse Traffic Channel.** A traffic channel on which data and signaling are transmitted  
32 from a mobile station to a base station.

33 **RMS.** Root of Mean Square.

34 **s.** Second.

1 **Satellite Clock Correction.** Bits nine through 24 of word eight, bits one through 24 of  
2 word nine, and bits one through 22 of word ten in GPS subframe one contain the  
3 parameters needed by the user for apparent satellite clock correction ( $t_{oc}$ ,  $a_{f2}$ ,  $a_{f1}$ ,  $a_{f0}$ ).

4 **Satellite Health.** Satellite health is the information identifying a satellite as usable for  
5 position calculation.

6 **Sensitivity.** The minimum level (dBm) of received GPS signal at a mobile station that  
7 allows the determination of the geolocation of the mobile station.

8 **Serving Frequency.** The CDMA frequency on which a mobile station is currently  
9 communicating with one or more base stations.

10 **Subframe.** See GPS Navigation Message Subframe.

11 **Superframe.** See GPS Navigation Message Superframe.

12 **SV.** Space Vehicle: A way of referring to one of the GPS satellites.

13 **Time of Arrival.** The time occurrence, as measured at the mobile station antenna input, of  
14 the earliest arriving usable multipath component of the signal.

15 **Traffic Channel.** A communication path between a mobile station and a base station used  
16 for user and signaling traffic. The term Traffic Channel implies a Forward Traffic Channel  
17 and Reverse Traffic Channel pair. See also Forward Traffic Channel and Reverse Traffic  
18 Channel.

19 **Unsolicited Response.** A response element that is issued in the absence of the  
20 corresponding request element.

21 **Walsh Function.** One of  $2^N$  time orthogonal binary functions (note that the functions are  
22 orthogonal after mapping '0' to 1 and '1' to -1).

23 **Weighting Factor.** Weighting factor is a weight applied to the GPS measurement as part of  
24 a Weighted Least Squares Filter (WLSF) implementation of the navigation algorithm.

25 **WGS-84.** World Geodetic System - 1984.

26 **WGS-84 Reference Ellipsoid.** Worldwide datum reference system defining the surface of  
27 the Earth (note: Supersedes WGS-72); i.e., the standard physical model of the Earth used  
28 for GPS applications. Ellipsoid reference models are location-specific and may be obtained  
29 from Defense Mapping Agency publication DMA TR 8350.2 (September 30, 1987).

30 **WLSF.** Weighted Least Squares Filter navigation algorithm.

31  
32  
33

### 1.3 General Test Procedures

The mobile station tests presented in this Specification support various position location technologies that use an implementation compliant with [1]. Only the tests that are applicable to the technology supported by the mobile station under testing should be performed.

All applicable tests shall be performed at least once. Test results will be recorded in real-time with all actual parametric performance logged where applicable.

### 1.4 Test Modes

Based on the position location call flows between the serving base station and the mobile station during the tests, the following four test modes are defined:

1. Position Location Test Mode 1: This test mode is used for testing position location operation when the mobile station originates a position location session<sup>1</sup> on the Access Channel. Parts of the subsequent messaging related to the position location session may be carried out on a dedicated channel using Location Service Option (Service Option 35 or 36).
2. Position Location Test Mode 2: This test mode is used for testing position location operation when the mobile station originates a position location session on a dedicated channel. This test mode is entered by setting up a call using Voice Service Option or Location Service Option (Service Option 35 or 36).
3. Position Location Test Mode 3: This test mode is used for testing position location operation when the base station originates a position location session on the Paging Channel. Parts of the subsequent messaging related to the position location session may be carried out on a dedicated channel using Location Service Option (Service Option 35 or 36).
4. Position Location Test Mode 4: This test mode is used for testing position location operation when the base station originates a position location session on a dedicated channel. This test mode is entered by setting up a call using a Voice Service Option supported by the mobile station or Location Service Option (Service Option 35 or 36).

Position Location Test Modes 1 and 2 are only applied to mobile stations that support mobile originated position location sessions.

Example call flows for these test modes are described in 5.8.2.

---

<sup>1</sup> The origination of the position location session, in general, is independent of the call origination. A position location session can, for example, be initiated by the PDE during a voice call, which had been originated by the mobile station. The initiator of the position location session is defined as the entity that sends the first *Position Determination Data Message*.

1    **1.5 Tolerances**

2    1.5.1 CDMA System Parameter Tolerances

3    CDMA parameters are specified in [7]. All parameters indicated in 2, 3 and 4 are exact,  
4    unless an explicit tolerance is stated.

5    1.5.2 Measurement Tolerances

6    Unless otherwise specified, a measurement tolerance, including the tolerance of the  
7    measurement equipment, of  $\pm 10\%$  is assumed. This  $\pm 10\%$  tolerance includes, but is not  
8    limited to the effects of VSWR, source signal levels, and variations in room temperature  
9    (15°C to 35°C).

10   **1.6 Measurement Data Evaluation**

11   The minimum specifications presented in this document describe tolerances applicable to  
12   numerical parameter values returned by the mobile station. The specified tolerance value  
13   types are summarized in Table 1.6-1.

14

1

**Table 1.6-1 Summary of Test Evaluation Parameters**

<b>Parameter</b>	<b>Description</b>
$T_1$	Time limit for returning <i>Provide MS Information</i>
$N$	Minimum number of required parameter values
$T_2$	Time limit for returning the $N$ parameter values
CODE <sub>1A</sub>	The maximum absolute error level corresponding to the 67% point for SV_CODE_PH_WH/SV_CODE_PH_FR
CODE <sub>2A</sub>	The maximum absolute error level corresponding to the 95% point for SV_CODE_PH_WH/SV_CODE_PH_FR
CODE <sub>1R</sub>	The maximum relative error level corresponding to the 67% point for SV_CODE_PH_WH/SV_CODE_PH_FR
CODE <sub>2R</sub>	The maximum relative error level corresponding to the 95% point for SV_CODE_PH_WH/SV_CODE_PH_FR
DPR <sub>1</sub>	The maximum error level corresponding to the 67% point for PS_DOPPLER
DPR <sub>2</sub>	The maximum error level corresponding to the 95% point for PS_DOPPLER
CNO <sub>1</sub>	The maximum error level corresponding to the 67% point for SV_CNO
CNO <sub>2</sub>	The maximum error level corresponding to the 95% point for SV_CNO
PNPHASE <sub>1</sub>	The maximum error level corresponding to the 67% point for PILOT_PN_PHASE
PNPHASE <sub>2</sub>	The maximum error level corresponding to the 95% point for PILOT_PN_PHASE
RXPWR <sub>1</sub>	The maximum error level corresponding to the 67% point for TOTAL_RX_PWR
RXPWR <sub>2</sub>	The maximum error level corresponding to the 95% point for TOTAL_RX_PWR
REFPS <sub>1</sub>	The maximum error level corresponding to the 67% point for REF_PILOT_STRENGTH
REFPS <sub>2</sub>	The maximum error level corresponding to the 95% point for REF_PILOT_STRENGTH
PS <sub>1</sub>	The maximum error level corresponding to the 67% point for PILOT_SRENGTH
PS <sub>2</sub>	The maximum error level corresponding to the 95% point for PILOT_SRENGTH

LATLONG <sub>1</sub>	The maximum error level corresponding to the 67% point for LAT/LONG
LATLONG <sub>2</sub>	The maximum error level corresponding to the 95% point for LAT/LONG
$R_1$	Lower limit for RMS error normalized by PS_RANGE_RMS_ER or RMS_ERR_PHASE
$R_2$	Upper limit for RMS error normalized by PS_RANGE_RMS_ER or RMS_ERR_PHASE

1

2 Detailed description of the values listed in Table 1.6-1 is given in 1.6.1 through 1.6.2.2.

## 3 1.6.1 Evaluation of the Measurement Yield

4 Unless otherwise noted, the following general procedures apply:

- 5 1. A given test consists of a series of independent measurements.<sup>2</sup>
- 6 2. A measurement is declared a success if the mobile station returns at least  $N$  instances  
7 of a designated parameter type within time period  $T_2$ , where both  $N$  and  $T_2$  are  
8 specified for each test. The designated parameter type is LAT/LONG in the *Provide*  
9 *Location Response* message, SV\_CODE\_PH\_WH/SV\_CODE\_PH\_FR in the *Provide*  
10 *Pseudorange Measurement* message, and PILOT\_PN\_PHASE in the *Provide Pilot Phase*  
11 *Measurement* message.<sup>3</sup> A measurement is declared a failure if the mobile station  
12 returns  $M$  parameters, with  $M < N$ , within time period  $T_2$ . The start of time period  $T_2$   
13 is set as follows:
  - 14 ▪ For Position Location Test Modes 1 and 2, the start of the time period is at the  
15 occurrence of the action evoking the position location session origination by the  
16 mobile station. (For example, pressing the last key in the sequence to start an  
17 emergency call.)

---

<sup>2</sup> In this document, ‘measurement’, when used in the context of position location, means the process that normally leads to obtaining a single position fix. The parameters returned by the mobile station during the course of a measurement (satellite code phase values, for example) themselves are not called measurements; they are called parameters or parameter values instead.

<sup>3</sup> The mobile station always returns the values of LAT and LONG as a pair, and these values are evaluated jointly by the procedures described in this document. This pair of values is considered a single parameter in this document designated by LAT/LONG. Similarly, SV\_CODE\_PH\_WH and SV\_CODE\_PH\_FR are also returned as a pair. This pair is also considered to be a single parameter designated by SV\_CODE\_PH\_WH/SV\_CODE\_PH\_FR.

- 1     ▪ For Position Location Test Modes 3 and 4, the start of the time period is at the end of  
2     the transmission of the message containing the measurement request by the base  
3     station.
- 4     3. The designated parameter values returned by the mobile station, for which the mobile  
5     station indicated an error, are not counted towards  $N$ . See Table 1.6.2.1.1-1 for the list  
6     of error indications.
- 7     4. If the mobile station returns redundant information during a single measurement, i.e. it  
8     returns more than one LAT/LONG parameter, or it returns more than one  
9     SV\_CODE\_PH\_WH/SV\_CODE\_PH\_FR parameter for the same satellite, or it returns  
10    more than one PILOT\_PN\_PHASE parameter for the same pilot, then only the first  
11    parameter for which the mobile station did not indicate an error will be counted towards  
12     $N$ .

### 13    1.6.2 Evaluation of the returned parameters

14    The performance tests described in this document (i.e. all tests other than the protocol  
15    tests) require carrying out a statistical analysis of the parameter values returned by the  
16    mobile station. The statistical analysis is performed for each parameter type separately, on  
17    a subset of the returned values. The following will apply to the construction of these  
18    subsets:

- 19    ▪ The parameter values returned by the mobile station, for which the mobile station  
20    indicated an error, are excluded from the statistical evaluation. See Table 1.6.2.1.1-1  
21    for the list of error indications.
- 22    ▪ If the mobile station returns redundant information during a single measurement, i.e.  
23    it returns more than one *Provide Location Response*, or it returns more than one  
24    satellite code phase record for the same satellite in *Provide Pseudorange Measurement*  
25    messages, or it returns more than one pilot phase record for the same pilot in *Provide*  
26    *Pilot Phase Measurement* messages, then only the first message or record, for which  
27    the mobile station did not indicate an error, will be included in the statistical  
28    evaluation. See Table 1.6.2.1.1-1 for the list of error indications.
- 29    ▪ The parameters returned by the mobile station after the expiration of specified time  
30    period  $T_2$  will be excluded from the evaluation.
- 31    ▪ If the mobile station returns more than  $N$  non-redundant parameters (i.e. parameters  
32    corresponding to distinct satellites or base stations) within time period  $T_2$ , then all  
33    the returned parameters that have no error indications will be included in the  
34    evaluation. See Table 1.6.2.1.1-1 for the list of error indications.

#### 35    1.6.2.1 Evaluation with $\sigma_1$ , $\sigma_2$ Type Tests

36    For all tested data fields, except for the returned RMS error estimate, a  $\sigma_1$ ,  $\sigma_2$  type test is  
37    performed. The  $\sigma_1$ ,  $\sigma_2$  type test comprises the following steps:

- 38    1. For each returned parameter, in each measurement, a non-negative error value  $\mathcal{E}$  is  
39    determined. The calculation of this error value for successful measurements is

1 described in 1.6.2.1.1. For failed measurements, where  $M$  valid parameters were  
2 returned within time period  $T_2$ , with  $M < N$ ,  $\mathcal{E}$  is set to any value greater than  $\sigma_2$  for  
3 each of the  $N - M$  missing parameters, where  $\sigma_2$  is the 95% point defined below.

- 4 2. If the mobile station returns parameter values corresponding to satellite or base station  
5 signals that were not simulated during the measurement, then for those parameters,  
6 the error is set to any value greater than  $\sigma_2$ , where  $\sigma_2$  is the 95% point defined below.
- 7 3. The mobile station is declared compliant with the minimum specification if the collected  
8 measurement results establish  $P(\mathcal{E} < \sigma_1) > 0.67$  and  $P(\mathcal{E} < \sigma_2) > 0.95$  with a given  
9 confidence level for all tested parameter types; where threshold levels  $\sigma_1$  and  $\sigma_2$  are  
10 specified for each parameter type for a given test, and the confidence level will be 90%  
11 unless otherwise stated. See Annex C for the description of the recommended method  
12 of statistical evaluation.

13 Hereinafter, the test method described in this paragraph will be called a  $\sigma_1, \sigma_2$  type test.

#### 14 1.6.2.1.1 Error Calculation

15 Unless specified otherwise, error  $\mathcal{E}$  is calculated as the absolute value of the difference  
16 between the returned parameter value and the true parameter value. Whenever a given  
17 parameter represents a vector (for example, horizontal position), the magnitude of the  
18 vector difference is taken. True parameter value, in this context, means a best estimate of  
19 the physical parameter value observable by the mobile station. The true value can be  
20 generated by interpolating between reference data sample points provided by the test  
21 equipment (for example, recorded reference SV-to-user range provided by the GPS  
22 simulator). Alternatively, the true value can be independently computed with an  
23 appropriate algorithm, based on the test scenario parameters. These or other methods for  
24 determining the true value are acceptable provided that all test equipment requirements  
25 listed in 5 are met.

26 The returned parameter fields and corresponding error indications are listed in Table  
27 1.6.2.1.1-1.

28

**Table 1.6.2.1.1-1 Returned Parameter Fields and Corresponding Error Indications**

<b>MS Response</b>	<b>Returned Parameter Field</b>	<b>Error Indication</b>	<b>Note</b>
<i>Provide Pseudorange Measurement</i>	SV_CODE_PH_WH	PS_RANGE_RMS_ER = '111111'	See 1.6.2.1.1.1, 1.6.2.1.1.2
	SV_CODE_PH_FR		
	PS_DOPPLER	PS_RANGE_RMS_ER = '111111'	See 1.6.2.1.1.3
	SV_CNO	PS_RANGE_RMS_ER = '111111'	See 1.6.2.1.1.4
<i>Provide Pilot Phase Measurement</i>	PILOT_PN_PHASE	RMS_ERR_PHASE = '111111'	See 1.6.2.1.1.5
	REF_PILOT_STRENGTH	RMS_ERR_PHASE = '111111'	See 1.6.2.1.1.4
	TOTAL_RX_POWER	RMS_ERR_PHASE = '111111'	See 1.6.2.1.1.4
	PILOT_STRENGTH	RMS_ERR_PHASE = '111111'	See 1.6.2.1.1.4
<i>Provide Location Response</i>	LAT	LOC_UNCRTNTY_A = '11110' or '11111' or LOC_UNCRTNTY_P = '11110' or '11111'	See 1.6.2.1.1.6
	LONG		

#### 1.6.2.1.1.1 Calculation of Absolute Satellite Code Phase Error

Satellite code phase values with error indications are discarded (see Table 1.6.2.1.1-1 for the list of error indications).

The absolute satellite code phase error represents the mobile station's measurement quality prior to the PDE operating on the measurements. This can also be referred to as the raw performance. The relative satellite code phase error represents the consistency of values returned for each satellite within a single measurement. The limits placed on the absolute and relative satellite code phase errors, together, define a level of performance equivalent to that defined by the LAT/LONG requirement.

1 The absolute satellite code phase error  $\delta_{i,j}$  is obtained as  $\delta_{i,j} = |e_{i,j}|$ , where  $e_{i,j}$  is defined

2 as<sup>4</sup> 
$$e_{i,j} = \begin{cases} \rho_{i,j} + 1023, & \text{if } \rho_{i,j} < -511 \\ \rho_{i,j} - 1023, & \text{if } \rho_{i,j} > 511 \\ \rho_{i,j}, & \text{otherwise} \end{cases}, \quad \text{with } \rho_{i,j} \text{ calculated as}$$

3 
$$\rho_{i,j} = \hat{r}_{i,j} - r_j(t_i) - C_{GPS} \cdot \left( \frac{MSTO_i}{16 \cdot C_{CDMA}} + \Delta T \right),$$
 where  $C_{GPS} = 1.023$  Mcps is the GPS C/A code

4 chip rate,  $C_{CDMA} = 1.2288$  Mcps is the CDMA chip rate,  $i$  is the measurement index,  $j$  is  
 5 the satellite index,  $\hat{r}_{i,j}$  is the satellite code phase value returned by the mobile station and  
 6  $r_j(t_i)$  is the true satellite code phase value at GPS time  $t_i$ , where  $t_i$  is derived from the  
 7 returned TIME\_REF field (expressed in CDMA system time) corresponding to the  
 8 measurement;  $MSTO_i$  is the value of the MOB\_SYS\_T\_OFFSET field reported by the mobile  
 9 station for the  $i^{\text{th}}$  measurement, and  $\Delta T$  is the independently measured base station to  
 10 GPS simulator timing offset (see 5.6). An advance in base station system time relative to  
 11 GPS simulator system time is represented by a positive  $\Delta T$  value. If OFFSET\_INCL is set  
 12 to '0' by the mobile station, then  $MSTO_i = 0$  assignment is used. Note,  $\Delta T$  shown in the  
 13 equation above represents a correction for a certain type of test equipment inaccuracy.  
 14 Other inaccuracies (for example, unequal cable length connecting the mobile station to the  
 15 GPS simulator and the base station) may be corrected for in a similar fashion. However, if  
 16 any or all of these corrections were already applied as part of the determination of the true  
 17 parameter value, then those corrections shall not be applied here.

#### 18 1.6.2.1.1.2 Calculation of Relative Satellite Code Phase Error

19 Satellite code phase values with error indications are discarded (see Table 1.6.2.1.1-1 for  
 20 the list of error indications). The relative satellite code phase error  $\delta'_{i,j}$  is obtained as

21 
$$\delta'_{i,j} = |\tilde{e}_{i,j}|$$
, where  $\tilde{e}_{i,j}$  is calculated as  $\tilde{e}_{i,j} = e_{i,j} - \bar{e}_i$ , where the  $e_{i,j}$  are obtained as

22 explained above, and  $\bar{e}_i$  is the mean error, calculated as  $\bar{e}_i = \frac{1}{l_i} \sum_{j=1}^{l_i} e_{i,j}$ , where  $l_i$  is the

23 number of satellite code phase values returned by the mobile station for the  $i^{\text{th}}$   
 24 measurement.

---

<sup>4</sup> This definition accommodates for the periodic nature of the GPS C/A code. The C/A code sequence has a period of  $2^{10}-1 = 1023$  chips.

### 1.6.2.1.1.3 Calculation of Pseudo Doppler Error

Pseudo Doppler values with error indications are discarded (see Table 1.6.2.1.1-1 for the list of error indications). The pseudo Doppler error  $\gamma'_{i,j}$  is obtained as  $\gamma'_{i,j} = |\tilde{d}_{i,j}|$ ; where  $\tilde{d}_{i,j}$  is calculated as  $\tilde{d}_{i,j} = d_{i,j} - \bar{d}_i$ , where  $d_{i,j}$  is the difference between the returned pseudo Doppler value and the true Doppler value at time  $t_i$ , where  $t_i$  is derived from the returned TIME\_REF field corresponding to the measurement; and  $\bar{d}_i$  is the mean error, calculated as  $\bar{d}_i = \frac{1}{l_i} \sum_{j=1}^{l_i} d_{i,j}$ , where  $l_i$  is the number of pseudo Doppler values returned by the mobile station for the  $i^{\text{th}}$  measurement.

### 1.6.2.1.1.4 Calculation of Signal-to-Noise Ratio and Signal Strength Errors

Signal-to-noise ratio and signal strength values with error indications are discarded (see Table 1.6.2.1.1-1 for the list of error indications). Signal-to-noise ratio and signal strength estimation errors are obtained as the absolute value of the difference between the reported value and the true value, both expressed in units given by the corresponding field definition of [1].

### 1.6.2.1.1.5 Calculation of Pilot Phase Error

Pilot phase values with error indications are discarded (see Table 1.6.2.1.1-1 for the list of error indications). The pilot phase error  $\mu_{i,j}$  is obtained as  $\mu_{i,j} = |m_{i,j}|$ , where  $m_{i,j}$  is

defined as<sup>5</sup> 
$$m_{i,j} = \begin{cases} \zeta_{i,j} + 2^{15}, & \text{if } \zeta_{i,j} < -2^{14} \\ \zeta_{i,j} - 2^{15}, & \text{if } \zeta_{i,j} > 2^{14} \\ \zeta_{i,j}, & \text{otherwise} \end{cases}, \quad \text{with } \zeta_{i,j} \text{ calculated as}$$

$\zeta_{i,j} = \hat{p}_{i,j} - p_j(t_i) - MSTO_i / 16 - C_{CDMA} \cdot \Delta T_j$ ; where  $C_{CDMA} = 1.2288$  Mcps is the CDMA chip rate,  $i$  is the measurement index,  $j$  is the base station index,  $\hat{p}_{i,j}$  is the pilot phase value returned by the mobile station, and  $p_j(t_i)$  is the true pilot phase value at time  $t_i$ , where  $t_i$  is the timestamp derived from the TIME\_REF\_MS field value for the  $i^{\text{th}}$  measurement;  $MSTO_i$  is the value of the MOB\_SYS\_T\_OFFSET field reported by the mobile station for the  $i^{\text{th}}$  measurement, and  $\Delta T_j$  is the independently measured timing offset between base station  $j$  (whose pilot phase is being reported) and the serving base station (see 5.4.2). An advance in base station system time relative to the serving base station system time is

---

<sup>5</sup> This definition accommodates for the periodic nature of the CDMA pilot PN code. The pilot PN code sequence has a period of  $2^{15} = 32768$  chips.

1 represented by a positive  $\Delta T_j$  value. If OFFSET\_INCL is set to '0' by the mobile station,  
2 then  $MSTO_i = 0$  assignment is used.

3 Note,  $\Delta T_j$  shown in the equation above represents a correction for a certain type of test  
4 equipment inaccuracy. Other inaccuracies (for example, unequal cable length connecting  
5 the mobile station to the different base stations) may be corrected for in a similar fashion.  
6 However, if any or all of these corrections were already applied as part of the determination  
7 of the true parameter value, then those corrections shall not be applied here.

#### 8 1.6.2.1.1.6 Calculation of Horizontal Position Error

9 Returned horizontal position values corresponding to Latitude and Longitude values that  
10 were indicated as erroneous by the mobile station according to Table 1.6.2.1.1-1 are not  
11 counted towards  $N$  and are discarded from the statistical evaluation. A horizontal position  
12 error is calculated as the magnitude of the difference vector between the reported and the  
13 nominal 2D positions, all expressed in units of 1 m.

#### 14 1.6.2.2 Evaluation of the Returned RMS Error Estimates

15 The RMS error estimate returned by the mobile station is evaluated as follows:

16 1. All returned values for a given parameter type (satellite code phase or pilot phase),  
17 excluding the values for which there was an error indication, are collected during the  $i^{\text{th}}$   
18 measurement to give  $x_{i,1}, x_{i,2}, \dots, x_{i,l_i}$ , where  $l_i$  is the total number of valid parameter  
19 values (satellite code phase or pilot phase) returned by the mobile station during the  $i^{\text{th}}$   
20 measurement.

21 2. For each value  $x_{i,j}$ , an error value  $\eta_{i,j}$  is calculated. For satellite code phase values,  
22  $\eta_{i,j}$  is assigned as  $\eta_{i,j} = \tilde{e}_{i,j}$ , while for pilot phase values,  $\eta_{i,j}$  is assigned as  $\eta_{i,j} = m_{i,j}$ ,  
23 where the  $\tilde{e}_{i,j}$  and  $m_{i,j}$  are calculated according to the description in 1.6.2.1.1.

24 3. For each  $\eta_{i,j}$ ,  $\tilde{\eta}_{i,j}$  is calculated as  $\tilde{\eta}_{i,j} = \eta_{i,j} - \bar{\eta}$ , where  $\bar{\eta}$  is the mean, calculated as  
25 
$$\bar{\eta} = \frac{1}{K} \sum_{i=1}^K \left( \frac{1}{l_i} \sum_{j=1}^{l_i} \eta_{i,j} \right)$$
, where  $K$  is the total number of measurements.

26 4. Each error value  $\tilde{\eta}_{i,j}$  is normalized<sup>6</sup> by dividing it with the corresponding RMS error  
27 estimate  $RMS_{i,j}$  returned by the mobile station, to get  $\eta'_{i,j} = \frac{\tilde{\eta}_{i,j}}{RMS_{i,j}}$ . The returned

---

<sup>6</sup> The resulting random variable  $\eta'_{i,j}$  would have unit variance with a perfect returned RMS error estimate.

1 RMS error estimate parameter fields and the corresponding error indications are listed  
 2 in Table 1.6.2.2-1.

3  
 4 **Table 1.6.2.2-1 Returned RMS Error Estimate Parameter Fields and Corresponding**  
 5 **Error Indications**

<b>MS Response</b>	<b>Parameter Field</b>	<b>Error Indication</b>
<i>Provide Pseudorange Measurement</i>	PS_RANGE_RMS_ER	PS_RANGE_RMS_ER = '111111'
<i>Provide Pilot Phase Measurement</i>	RMS_ERR_PHASE	RMS_ERR_PHASE = '111111'

6  
 7 5. The average normalized RMS error  $R$  is calculated as  $R = \sqrt{\frac{1}{K} \sum_{i=1}^K \left( \frac{1}{L_i} \sum_{j=1}^{L_i} \eta'_{i,j} \right)^2}$ .

8 The mobile station is declared compliant with the minimum specification if  $R_1 \leq R \leq R_2$  is  
 9 satisfied, where threshold levels  $R_1$  and  $R_2$  are specified for each test.



## 2 GPS MINIMUM SPECIFICATIONS

The tests described in this section shall be performed for GPS capable mobile stations. GPS capable mobile stations may return *Provide Pseudorange Measurement* messages or *Provide Location Response* messages. For a mobile station that is capable of returning *Provide Pseudorange Measurement* messages, the parameter fields of that message will be tested. For a mobile station that is capable of returning *Provide Location Response* messages, the parameter fields of that message will be tested. The following comments apply to all GPS test cases:

- The serving base station pilot PN offset corresponds directly to PILOT\_PN in the *Sync Channel Message* and to REF\_PN in the PDE simulator GPS assistance messages.
- The serving base station power is set to  $\bar{I}_{or} = -70$  dBm.
- The simulated locations (not the actual physical locations) of the mobile station and the serving base station are as follows: In the stationary and protocol tests, the serving base station is due north from the mobile station at a distance of  $5/\sqrt{3}$  km. In the moving scenario test, the mobile station's trajectory is circular in the horizontal plane, with a radius of 1 km centered at the serving base station location. See Annex B for detailed location data.
- The limit values for each measurement parameter represent an interpretation of the returned values with the units stated and are not the actual returned binary values.

### 2.1 GPS Performance Specifications

The performance specifications described in this section set a minimum acceptable level of accuracy for the GPS based measurements returned by the mobile station under various test conditions.

#### 2.1.1 Stationary Location Tests

In stationary location tests, the signal environment is set such that a stationary mobile station location is simulated.

##### 2.1.1.1 GPS Accuracy Test

###### 2.1.1.1.1 Definition

The purpose of this test is to determine the mobile station's capability to obtain precise GPS measurements under favorable signal conditions and good satellite geometry. The GPS simulator shall provide high SNR signals representing eight satellites with HDOP less than 1.6. Note that the GPS assistance provided by the serving base station is not limited to eight satellites during this test. A sequence of independent measurements is carried out. In each measurement, the mobile station shall return a *Provide Location Response* message if the mobile station is capable of location computation; or it shall return one or more *Provide Pseudorange Measurement* messages if it is not capable of location computation. The test may be stopped when the required confidence levels are met for all tested parameters.

## 2.1.1.1.2 Method of Measurement

1. Connect a base station simulator and a GPS simulator to the mobile station as shown in Figure 5.9.1-1.
2. For each band class that the mobile station supports, configure the mobile station to operate in that band class and perform steps 3 through 13.
3. Configure the base station according to the standard test parameters listed in 5.9.2.
4. Configure the GPS simulator according to the standard test parameters listed in Annex B.
5. Set the GPS simulator output levels according to Table 2.1.1.1.2-1. Satellites not listed in Table 2.1.1.1.2-1 shall not be simulated.

**Table 2.1.1.1.2-1 Satellite Signal Levels for the GPS Accuracy Test**

Satellite PRN Number	Signal Level (dBm)	C/N <sub>0</sub> (dB-Hz)
3, 14, 15, 17, 18, 21, 29, 31	-130	44

6. Measure and record the time offset between the base station and the GPS simulator time base (see 5.6).
7. Repeat Steps 8 through 13.
8. Power up the mobile station.
9. Reset previous measurements, computed positions, values calculated during previous fixes and GPS system time.
10. Initiate a mobile terminated voice call.
11. Initiate a Test Mode 4 session.
12. Record the values returned by the mobile station.
13. Power down the mobile station.

## 2.1.1.1.3 Minimum Specification

The parameters returned by the mobile station shall satisfy the requirements listed in Table 2.1.1.1.3-1; the confidence level for all  $\sigma_1$ ,  $\sigma_2$  type tests shall be 90% (see also 1.6).

1 **Table 2.1.1.1.3-1 Minimum Specifications for the GPS Accuracy Test**

Mobile Station Response	Parameter Field	Limit Parameter	Limit Value
<i>Provide MS Information</i>	N/A	$T_1$	750 ms
<i>Provide Pseudorange Measurement</i>	SV_CODE_PH_WH SV_CODE_PH_FR	$N$	4
		$T_2$	16 s
		CODE <sub>1R</sub>	0.05 GPS chips
		CODE <sub>2R</sub>	0.15 GPS chips
		CODE <sub>1A</sub>	0.22 GPS chips
		CODE <sub>2A</sub>	0.32 GPS chips
	PS_DOPPLER	DPR <sub>1</sub>	30 Hz
		DPR <sub>2</sub>	50 Hz
	SV_CNO	CNO <sub>1</sub>	4 dB-Hz
		CNO <sub>2</sub>	6 dB-Hz
	PS_RANGE_RMS_ER	$R_1$	0
		$R_2$	3
<i>Provide Location Response</i>	LAT	$N$	1
		$T_2$	16 s
	LONG	LATLONG <sub>1</sub>	25 m
		LATLONG <sub>2</sub>	75 m

2

## 3 2.1.1.2 GPS Dynamic Range Test

## 4 2.1.1.2.1 Definition

5 The purpose of this test is to determine the mobile station's capability to obtain precise GPS  
6 measurements under variable (strong to weak) signal conditions while stationary. The test  
7 covers signal strength ranging from -125 dBm to -146 dBm. The GPS simulator shall  
8 provide signals representing eight satellites with HDOP less than 1.6. Note that the GPS  
9 assistance provided by the serving base station is not limited to eight satellites during this  
10 test. A sequence of independent measurements is carried out. In each measurement, the  
11 mobile station shall return a *Provide Location Response* message if the mobile station is  
12 capable of location computation; or it shall return one or more *Provide Pseudorange*  
13 *Measurement* messages if it is not capable of location computation. The test may be  
14 stopped when the required confidence levels are met for all tested parameters.

## 2.1.1.2.2 Method of Measurement

1. Connect a base station simulator and a GPS simulator to the mobile station as shown in Figure 5.9.1-1.
2. For each band class that the mobile station supports, configure the mobile station to operate in that band class and perform steps 3 through 13.
3. Configure the base station according to the standard test parameters listed in 5.9.2.
4. Configure the GPS simulator according to the standard test parameters listed in Annex B.
5. Set the GPS simulator output levels according to Table 2.1.1.2.2-1. Satellites not listed in Table 2.1.1.2.2-1 shall not be simulated.

**Table 2.1.1.2.2-1 Satellite Signal Levels for the GPS Dynamic Range Test**

Satellite PRN Number	Signal Level (dBm)	C/N <sub>0</sub> (dB-Hz)
3	-125	49
14	-128	46
15	-131	43
17	-134	40
18	-137	37
21	-140	34
29	-143	31
31	-146	28

6. Measure and record the time offset between the base station and the GPS simulator time base (see 5.6).
7. Repeat Steps 8 through 13.
8. Power up the mobile station.
9. Reset previous measurements, computed positions, values calculated during previous fixes and GPS system time.
10. Initiate a mobile terminated voice call.
11. Initiate a Test Mode 4 session.
12. Record the values returned by the mobile station.
13. Power down the mobile station.

## 2.1.1.2.3 Minimum Specification

The parameters returned by the mobile station shall satisfy the requirements listed in Table 2.1.1.2.3-1; the confidence level for all  $\sigma_1$ ,  $\sigma_2$  type tests shall be 90% (see also 1.6).

**Table 2.1.1.2.3-1 Minimum Specifications for the GPS Dynamic Range Test**

Mobile Station Response	Parameter Field	Limit Parameter	Limit Value
<i>Provide MS Information</i>	N/A	$T_1$	750 ms
<i>Provide Pseudorange Measurement</i>	SV_CODE_PH_WH SV_CODE_PH_FR	$N$	8
		$T_2$	32 s
		CODE <sub>1R</sub>	0.1 GPS chips
		CODE <sub>2R</sub>	0.3 GPS chips
		CODE <sub>1A</sub>	0.3 GPS chips
		CODE <sub>2A</sub>	0.6 GPS chips
	PS_DOPPLER	DPR <sub>1</sub>	40 Hz
		DPR <sub>2</sub>	80 Hz
	SV_CNO	CNO <sub>1</sub>	4 dB-Hz
		CNO <sub>2</sub>	6 dB-Hz
PS_RANGE_RMS_ER	$R_1$	0	
	$R_2$	3	
<i>Provide Location Response</i>	LAT LONG	$N$	1
		$T_2$	16 s
		LATLONG <sub>1</sub>	50 m
		LATLONG <sub>2</sub>	150 m

## 2.1.1.3 GPS Sensitivity Test

## 2.1.1.3.1 Definition

The purpose of this test is to determine the mobile station's capability to obtain GPS measurements under weak satellite signal conditions. The GPS simulator shall provide low SNR signals representing four satellites with HDOP less than 2.1. Note that the GPS assistance provided by the serving base station is not limited to four satellites during this test. A sequence of independent measurements is carried out. In each measurement, the mobile station shall return a *Provide Location Response* message if the mobile station is capable of location computation; or it shall return one or more *Provide Pseudorange*

1 *Measurement* messages if it is not capable of location computation. The test may be  
2 stopped when the required confidence levels are met for all tested parameters.

### 3 2.1.1.3.2 Method of Measurement

- 4 1. Connect a base station simulator and a GPS simulator to the mobile station as shown in  
5 Figure 5.9.1-1.
- 6 2. For each band class that the mobile station supports, configure the mobile station to  
7 operate in that band class and perform steps 3 through 13.
- 8 3. Configure the base station according to the standard test parameters listed in 5.9.2.
- 9 4. Configure the GPS simulator according to the standard test parameters listed in Annex  
10 B.
- 11 5. Set the GPS simulator output levels according to Table 2.1.1.3.2-1. Satellites not listed  
12 in Table 2.1.1.3.2-1 shall not be simulated.

13  
14 **Table 2.1.1.3.2-1 Satellite Signal Levels for the GPS Sensitivity Test**

<b>Satellite PRN Number</b>	<b>Signal Level (dBm)</b>	<b>C/N<sub>0</sub> (dB-Hz)</b>
14, 17, 21, 31	-147	27

- 15
- 16 6. Measure and record the time offset between the base station and the GPS simulator  
17 time base (see 5.6).
- 18 7. Repeat Steps 8 through 13.
- 19 8. Power up the mobile station.
- 20 9. Reset previous measurements, computed positions, values calculated during previous  
21 fixes and GPS system time.
- 22 10. Initiate a mobile terminated voice call.
- 23 11. Initiate a Test Mode 4 session.
- 24 12. Record the values returned by the mobile station.
- 25 13. Power down the mobile station.

### 26 2.1.1.3.3 Minimum Specification

27 The parameters returned by the mobile station shall satisfy the requirements listed in Table  
28 2.1.1.3.3-1; the confidence level for all  $\sigma_1$ ,  $\sigma_2$  type tests shall be 90% (see also 1.6).

1 **Table 2.1.1.3.3-1 Minimum Specifications for the GPS Sensitivity Test**

Mobile Station Response	Parameter Field	Limit Parameter	Limit Value
<i>Provide MS Information</i>	N/A	$T_1$	750 ms
<i>Provide Pseudorange Measurement</i>	SV_CODE_PH_WH SV_CODE_PH_FR	$N$	4
		$T_2$	16 s
		CODE <sub>1R</sub>	0.11 GPS chips
		CODE <sub>2R</sub>	0.33 GPS chips
		CODE <sub>1A</sub>	0.31 GPS chips
		CODE <sub>2A</sub>	0.63 GPS chips
	PS_DOPPLER	DPR <sub>1</sub>	40 Hz
		DPR <sub>2</sub>	80 Hz
	SV_CNO	CNO <sub>1</sub>	4 dB-Hz
		CNO <sub>2</sub>	6 dB-Hz
	PS_RANGE_RMS_ER	$R_1$	0
$R_2$		3	
<i>Provide Location Response</i>	LAT	$N$	1
		$T_2$	16 s
	LONG	LATLONG <sub>1</sub>	60 m
		LATLONG <sub>2</sub>	180 m

2

## 3 2.1.1.4 GPS Multipath Accuracy Test

## 4 2.1.1.4.1 Definition

5 The purpose of this test is to determine the mobile station's capability to obtain precise GPS  
6 measurements under a simple, two-ray GPS multipath environment and good satellite  
7 geometry. The GPS simulator shall provide signals representing a total of five satellites with  
8 HDOP less than 1.7. Two separate GPS signals shall be produced for three of the five GPS  
9 satellites being simulated and presented to the mobile station under test, one representing  
10 an attenuated, direct path and one representing a higher amplitude, delayed multipath  
11 signal. Note that the GPS assistance provided by the serving base station is not limited to  
12 five satellites during this test. A sequence of independent measurements is carried out. In  
13 each measurement, the mobile station shall return a *Provide Location Response* message if  
14 the mobile station is capable of location computation; or it shall return one or more *Provide*  
15 *Pseudorange Measurement* messages if it is not capable of location computation. The test  
16 may be stopped when the required confidence levels are met for all tested parameters.

2.1.1.4.2 Method of Measurement

1. Connect a base station simulator and a GPS simulator to the mobile station as shown in Figure 5.9.1-1.
2. For each band class that the mobile station supports, configure the mobile station to operate in that band class and perform steps 3 through 13.
3. Configure the base station according to the standard test parameters listed in 5.9.2.
4. Configure the GPS simulator according to the standard test parameters listed in Annex B. The Doppler shift of the multipath signal relative to the direct signal shall be a maximum of 0.5 Hz.
5. Set the GPS simulator output levels according to Table 2.1.1.4.2-1. Satellites not listed in Table 2.1.1.4.2-1 shall not be simulated.

**Table 2.1.1.4.2-1 Satellite Signal Levels for the GPS Multipath Accuracy Test**

Satellite PRN Number	Signal Level (dBm)	C/N <sub>0</sub> (dB-Hz)	Delay (GPS Chips)
14, 17, 18	-144	30	0
14, 17, 18	-141	33	2
21, 31	-141	33	0

6. Measure and record the time offset between the base station and the GPS simulator time base (see 5.6).
7. Repeat Steps 8 through 13.
8. Power up the mobile station.
9. Reset previous measurements, computed positions, values calculated during previous fixes and GPS system time.
10. Initiate a mobile terminated voice call.
11. Initiate a Test Mode 4 session.
12. Record the values returned by the mobile station.
13. Power down the mobile station.

2.1.1.4.3 Minimum Specification

The parameters returned by the mobile station shall satisfy the requirements listed in Table 2.1.1.4.3-1; the confidence level for all  $\sigma_1$ ,  $\sigma_2$  type tests shall be 90% (see also 1.6).

1 **Table 2.1.1.4.3-1 Minimum Specifications for the GPS Multipath Accuracy Test**

Mobile Station Response	Parameter Field	Limit Parameter	Limit Value
<i>Provide MS Information</i>	N/A	$T_1$	750 ms
<i>Provide Pseudorange Measurement</i>	SV_CODE_PH_WH SV_CODE_PH_FR	$N$	4
		$T_2$	16 s
		CODE <sub>1R</sub>	0.11 GPS chips
		CODE <sub>2R</sub>	0.33 GPS chips
		CODE <sub>1A</sub>	0.31 GPS chips
		CODE <sub>2A</sub>	0.63 GPS chips
	PS_DOPPLER	DPR <sub>1</sub>	35 Hz
		DPR <sub>2</sub>	70 Hz
	SV_CNO	CNO <sub>1</sub>	4 dB-Hz
		CNO <sub>2</sub>	6 dB-Hz
	PS_RANGE_RMS_ER	$R_1$	0
		$R_2$	3
<i>Provide Location Response</i>	LAT	$N$	1
		$T_2$	16 s
	LONG	LATLONG <sub>1</sub>	60 m
		LATLONG <sub>2</sub>	180 m

2

3 2.1.2 Moving Scenario Test

4 2.1.2.1 Moving Scenario GPS Accuracy Test

5 2.1.2.1.1 Definition

6 The purpose of this test is to determine the mobile station's capability to obtain precise GPS  
7 measurements under favorable signal conditions, when the mobile station is in motion.  
8 The mobile station's trajectory is circular in the horizontal plane, with a radius of 1 km.  
9 The mobile station's speed is constant at 100 km/h. The GPS simulator shall provide high  
10 SNR signals representing eight satellites with HDOP less than 1.6. Note that the GPS  
11 assistance provided by the serving base station is not limited to eight satellites during this  
12 test. A sequence of independent measurements is carried out. In each measurement, the  
13 mobile station shall return a *Provide Location Response* message if the mobile station is  
14 capable of location computation; or it shall return one or more *Provide Pseudorange*

1 *Measurement* messages if it is not capable of location computation. The test may be  
 2 stopped when the required confidence levels are met for all tested parameters.

3 2.1.2.1.2 Method of Measurement

- 4 1. Connect a base station simulator and a GPS simulator to the mobile station as shown in  
 5 Figure 5.9.1-1.
- 6 2. For each band class that the mobile station supports, configure the mobile station to  
 7 operate in that band class and perform steps 3 through 13.
- 8 3. Configure the base station according to the standard test parameters listed in 5.9.2.
- 9 4. Configure the GPS simulator according to the standard test parameters listed in Annex  
 10 B.
- 11 5. Set the GPS simulator output levels according to Table 2.1.2.1.2-1. Satellites not listed  
 12 in Table 2.1.2.1.2-1 shall not be simulated.

14 **Table 2.1.2.1.2-1 Satellite Signal Levels for the Moving Scenario GPS Accuracy Test**

Satellite PRN Number	Signal Level (dBm)	C/No (dB-Hz)
3, 14, 15, 17, 18, 21, 29, 31	-130	44

- 15
- 16 6. Measure and record the time offset between the base station and the GPS simulator  
 17 time base (see 5.6).
- 18 7. Repeat Steps 8 through 13.
- 19 8. Power up the mobile station.
- 20 9. Reset previous measurements, computed positions, values calculated during previous  
 21 fixes and GPS system time.
- 22 10. Initiate a mobile terminated voice call.
- 23 11. Initiate a Test Mode 4 session.
- 24 12. Record the values returned by the mobile station.
- 25 13. Power down the mobile station.

26 2.1.2.1.3 Minimum Specification

27 The parameters returned by the mobile station shall satisfy the requirements listed in Table  
 28 2.1.2.1.3-1; the confidence level for all  $\sigma_1$ ,  $\sigma_2$  type tests shall be 90% (see also 1.6).

1 **Table 2.1.2.1.3-1 Minimum Specifications for the Moving Scenario GPS Accuracy Test**

Mobile Station Response	Parameter Field	Limit Parameter	Limit Value
<i>Provide MS Information</i>	N/A	$T_1$	750 ms
<i>Provide Pseudorange Measurement</i>	SV_CODE_PH_WH SV_CODE_PH_FR	$N$	4
		$T_2$	16 s
		CODE <sub>1R</sub>	0.07 GPS chips
		CODE <sub>2R</sub>	0.22 GPS chips
		CODE <sub>1A</sub>	0.4 GPS chips
		CODE <sub>2A</sub>	0.7 GPS chips
	PS_DOPPLER	DPR <sub>1</sub>	35 Hz
		DPR <sub>2</sub>	70 Hz
	SV_CNO	CNO <sub>1</sub>	4 dB-Hz
		CNO <sub>2</sub>	6 dB-Hz
	PS_RANGE_RMS_ER	$R_1$	0
		$R_2$	3
<i>Provide Location Response</i>	LAT	$N$	1
		$T_2$	16 s
	LONG	LATLONG <sub>1</sub>	35 m
		LATLONG <sub>2</sub>	105 m

2

3 **2.2 GPS Protocol Tests**

4 The protocol tests presented in this section shall be performed if the tests listed in 3.3  
5 (AFLT Protocol Tests) are not performed.

6 **2.2.1 GPS Position Location Session on the Paging Channel Test**

7 **2.2.1.1 Definition**

8 The purpose of this test is to determine the mobile station's capability to operate in a mode  
9 when the base station initiates a position location session on the Paging Channel.

10 **2.2.1.2 Method of Measurement**

- 11 1. Connect a base station simulator and a GPS simulator to the mobile station as shown in  
12 Figure 5.9.1-1.
- 13 2. Configure the mobile station to operate in a band class it supports.

- 1 3. Configure the base station according to the standard test parameters listed in 5.9.2.
- 2 4. Configure the GPS simulator according to the standard test parameters listed in Annex
- 3 B.
- 4 5. Set the GPS simulator output levels according to Table 2.2.1.2-1. Satellites not listed in
- 5 Table 2.2.1.2-1 shall not be simulated.

6  
7 **Table 2.2.1.2-1 Satellite Signal Levels for the Protocol Tests**

Satellite PRN Number	Signal Level (dBm)	C/No (dB-Hz)
3, 14, 15, 17, 18, 21, 29, 31	-130	44

- 8
- 9 6. Power up the mobile station.
- 10 7. Reset previous measurements, computed positions, values calculated during previous
- 11 fixes and GPS system time.
- 12 8. Initiate a mobile terminated voice call.
- 13 9. Initiate a Test Mode 3 session.
- 14 10. Record the values returned by the mobile station.
- 15 11. Power down the mobile station.

16 2.2.1.3 Minimum Specification

17 The mobile station shall respond to base station requests received on the Paging Channel  
 18 and it shall complete the position location session by returning a *Provide Location Response*  
 19 message if the mobile station is capable of location computation; or it shall return one or  
 20 more *Provide Pseudorange Measurement* messages if it is not capable of location  
 21 computation. The parameters returned by the mobile station shall satisfy the requirements  
 22 listed in Table 2.2.1.3-1 (see also 1.6).

**Table 2.2.1.3-1 Minimum Specifications for the GPS Position Location Session on the Paging Channel Test**

<b>Mobile Station Response</b>	<b>Parameter Field</b>	<b>Limit Parameter</b>	<b>Limit Value</b>
<i>Provide Pseudorange Measurement</i>	SV_CODE_PH_WH	$N$	4
	SV_CODE_PH_FR	$T_2$	16 s
<i>Provide Location Response</i>	LAT	$N$	1
	LONG	$T_2$	16 s

## 2.2.2 Mobile Station Originated GPS Position Location Session Test

These tests shall only be applied to mobile stations that support mobile station originated position location sessions.

### 2.2.2.1 Mobile Station Originated GPS Position Location Session on the Access Channel

#### 2.2.2.1.1 Definition

This test shall be only applied to mobile stations that support position location session origination on the Access Channel. The purpose of this test is to determine the mobile station's capability to operate in a mode where the position location session is originated by the mobile station

#### 2.2.2.1.2 Method of Measurement

1. Connect a base station simulator and a GPS simulator to the mobile station as shown in Figure 5.9.1-1.
2. Configure the mobile station to operate in a band class it supports.
3. Configure the base station according to the standard test parameters listed in 5.9.2.
4. Configure the GPS simulator according to the standard test parameters listed in Annex B.
5. Set the GPS simulator output levels according to Table 2.2.1.2-1. Satellites not listed in Table 2.2.1.2-1 shall not be simulated.
6. Power up the mobile station.
7. Reset previous measurements, computed positions, values calculated during previous fixes and GPS system time.
8. Initiate a Test Mode 1 session.
9. Record the values returned by the mobile station or the computed location stored in the mobile station.

1 10. Power down the mobile station.

### 2 2.2.2.1.3 Minimum Specification

3 The mobile station shall complete the position location session by returning one or more  
4 *Provide Pseudorange Measurement* messages if it is not capable of location computation or  
5 by computing its own location otherwise.

6 Note, if the mobile station is capable of location computation, it may return neither  
7 pseudorange measurement values nor the calculated position during this test. In this case  
8 the calculated position shall be retrieved from the mobile station by other means (for  
9 example, through the data port).

10 The parameters returned or computed by the mobile station shall satisfy the requirements  
11 listed in Table 2.2.2.1.3-1 (see also 1.6).

12 Note, time limit  $T_2$  applies to the measurement time period that starts when the position  
13 location session is invoked at the mobile station.

14  
15 **Table 2.2.2.1.3-1 Minimum Specifications for the Mobile Station Originated GPS**  
16 **Position Location Session Tests**

<b>Mobile Station Response</b>	<b>Parameter Field</b>	<b>Limit Parameter</b>	<b>Limit Value</b>
<i>Provide Pseudorange Measurement</i>	SV_CODE_PH_WH	$N$	4
	SV_CODE_PH_FR	$T_2$	16 s
Computed Mobile Station Location	N/A	$N$	1
		$T_2$	16 s

### 18 2.2.2.2 Mobile Station Originated GPS Position Location Session on a Dedicated Channel

#### 19 2.2.2.2.1 Definition

20 This test shall only be applied to mobile stations that support position location session  
21 origination on a dedicated channel. The purpose of this test is to determine the mobile  
22 station's capability to operate in a mode where the position location session is originated by  
23 the mobile station

#### 24 2.2.2.2.2 Method of Measurement

- 25 1. Connect a base station simulator and a GPS simulator to the mobile station as shown in  
26 Figure 5.9.1-1.
- 27 2. Configure the mobile station to operate in a band class it supports.
- 28 3. Configure the base station according to the standard test parameters listed in 5.9.2.

- 1 4. Configure the GPS simulator according to the standard test parameters listed in Annex  
2 B.
- 3 5. Set the GPS simulator output levels according to Table 2.2.1.2-1. Satellites not listed in  
4 Table 2.2.1.2-1 shall not be simulated.
- 5 6. Power up the mobile station.
- 6 7. Reset previous measurements, computed positions, values calculated during previous  
7 fixes and GPS system time.
- 8 8. Set up a mobile station originated voice call.
- 9 9. Initiate a Test Mode 2 session.
- 10 10. Record the values returned by the mobile station or the computed location stored in the  
11 mobile station
- 12 11. Power down the mobile station

#### 13 2.2.2.2.3 Minimum Specification

14 The mobile station shall complete the position location session by returning one or more  
15 *Provide Pseudorange Measurement* messages if it is not capable of location computation or  
16 by computing its own location otherwise.

17 Note, if the mobile station is capable of location computation, it may return neither  
18 pseudorange measurement values nor the calculated position during this test. In this case  
19 the calculated position shall be retrieved from the mobile station by other means (for  
20 example, through the data port).

21 The parameters returned or computed by the mobile station shall satisfy the requirements  
22 listed in Table 2.2.2.1.3-1 (see also 1.6).

23 Note, time limit  $T_2$  applies to the measurement time period that starts at invoking the  
24 position location session at the mobile station.

25



### 3 AFLT MINIMUM SPECIFICATION

The tests described in this section shall be performed for AFLT capable mobile stations.

#### 3.1 General Comments on AFLT Tests

The following comments apply to all AFLT test cases:

- AFLT tests only reflect 2D location processing.
- Only cases where three base stations (base station 1, 2 and 3) can be observed by the mobile station are examined.
- Although the *Provide Pilot Phase Measurement* message specified in [1] enables the mobile station to simultaneously report pilot phase measurements for more than one CDMA frequency or Band Class, the tests included in this Specification do not cover that capability.
- AFLT tests are described as using base stations or base station simulators, but it is understood that equivalent pilot generators for the non-serving base stations may be used.
- No handoff scenario tests are included, the serving base station is always base station 1.
- For all AFLT tests, base station 1 pilot PN offset is  $P_0$ , base station 2 pilot PN offset is  $P_1$  and base station 3 PN offset is  $P_2$ , where  $P_0$ ,  $P_1$  and  $P_2$  are arbitrary values satisfying the requirements listed in 5.9.2. Furthermore,  $P_0$  corresponds to PILOT\_PN in the *Sync Channel Message*, while  $P_1$  and  $P_2$  correspond to the appropriate values in both the *General Neighbor List Message* (see Table 5.9.2-4) and the PDE simulator *Provide Base Station Almanac* message.
- For all AFLT tests, the simulated locations (not the actual physical locations) of the mobile station and the base stations are as follows: The three base stations form an equilateral triangle with the mobile station being at the geometric center of the triangle. Each base station is at a distance of 5 km from every other base station; thus, the mobile station is at a distance of  $5/\sqrt{3}$  km from each base station. Base station 1 is due north from the mobile station, and base station 2 is southeast from the mobile station. See Annex B for detailed location data. Note, because of the above configuration, the true time offset between the base stations' signals observed at the mobile station's location should be zero.
- If the mobile station is capable of location computation based on AFLT measurements (Bit 3 or Bit 8 or both is set to '1' in the *Provide MS Information* message sent by the mobile station), and the returned location is evaluated, then the alternative base station synchronization method described in 5.4.2 shall not be used. Instead, the stricter requirement of maintaining less than 30 ns timing offset between the base stations shall be met (see 5.4.2).
- The limit values for each measurement parameter represent an interpretation of the returned values with the units stated and are not the actual returned binary values.

## 3.2 AFLT Performance Specifications

The measurement performance specifications described in this section set a minimum acceptable level of accuracy for the AFLT measurements returned by the mobile station under various test conditions.

### 3.2.1 AFLT Accuracy Test

#### 3.2.1.1 Definition

The purpose of this test is to determine the mobile station's capability to obtain precise pilot phase measurements under favorable signal level and HDOP conditions. The base station simulators shall provide high SNR signals representing three base stations. A sequence of independent measurements is carried out. In each measurement, the mobile station shall return a *Provide Location Response* message if the mobile station is capable of location computation; or it shall return one or more *Provide Pilot Phase Measurement* messages if it is not capable of location computation. The test may be stopped when the required confidence levels are met for all tested parameters.

#### 3.2.1.2 Method of Measurement

1. Connect three base station simulators and an AWGN generator to the mobile station as shown in Figure 5.9.1-2.
2. For each band class that the mobile station supports, configure the mobile station to operate in that band class and perform steps 3 through 12.
3. Configure the serving base station according to the standard test parameters listed in 5.9.2.
4. Set the base station simulator and AWGN generator output levels according to Table 3.2.1.2-1.

**Table 3.2.1.2-1 Signal Levels for the AFLT Accuracy Test**

Parameter	Unit	Base Station 1	Base Station 2	Base Station 3
$\bar{I}_{Or}/I_{Oc}$	dB	3	0	0
$I_{Oc}$	dBm/1.23 MHz	-58		
$\frac{\text{Pilot } E_C}{I_0}$	dB	-11	-14	-14

Note: The Pilot  $E_C/I_0$  value is calculated from the parameters in the table. It is not a directly settable parameter.

5. Measure and record the time offset between the base stations (see 5.4.2).
6. Repeat Steps 7 through 12.

- 1 7. Power up the mobile station.
- 2 8. Reset the position location related parameters stored by the mobile station.
- 3 9. Initiate a mobile terminated voice call.
- 4 10. Initiate a Test Mode 4 session.
- 5 11. Record the values returned by the mobile station.
- 6 12. Power down the mobile station.

### 7 3.2.1.3 Minimum Specification

8 The parameters returned by the mobile station shall satisfy the requirements listed in Table  
 9 3.2.1.3-1; the confidence level for all  $\sigma_1$ ,  $\sigma_2$  type tests shall be 90% (see also 1.6).

10

11

**Table 3.2.1.3-1 Minimum Specifications for the AFLT Accuracy Test**

<b>Mobile Station Response</b>	<b>Parameter Field</b>	<b>Limit Parameter</b>	<b>Limit Value</b>
<i>Provide MS Information</i>	N/A	$T_1$	750 ms
<i>Provide Pilot Phase Measurement</i>	PILOT_PN_PHASE	$N$	3
		$T_2$	8 s
		PNPHASE <sub>1</sub>	3/16 PN chips
		PNPHASE <sub>2</sub>	1/2 PN chips
	TOTAL_RX_PWR	RXPWR <sub>1</sub>	10 dBm/1.23 MHz
		RXPWR <sub>2</sub>	12 dBm/1.23 MHz
	REF_PILOT_STRENGTH	REFPS <sub>1</sub>	2.5 dB
		REFPS <sub>1</sub>	3.5 dB
	PILOT_STRENGTH	PS <sub>1</sub>	2.5 dB
		PS <sub>1</sub>	3.5 dB
RMS_ERR_PHASE	$R_1$	0	
	$R_2$	3	
<i>Provide Location Response</i>	LAT LONG	$N$	1
		$T_2$	8 s
		LATLONG <sub>1</sub>	45 m
		LATLONG <sub>2</sub>	135 m

12

## 3.2.2 AFLT Sensitivity Test

### 3.2.2.1 Definition

The purpose of this test is to determine the mobile station's capability to obtain pilot phase measurements under weak signal level conditions. The base station simulators shall provide a high SNR serving sector signal and two low SNR neighbor pilot signals. A sequence of independent measurements is carried out. In each measurement, the mobile station shall return a *Provide Location Response* message if the mobile station is capable of location computation; or it shall return one or more *Provide Pilot Phase Measurement* messages if it is not capable of location computation. The test may be stopped when the required confidence levels are met for all tested parameters.

### 3.2.2.2 Method of Measurement

1. Connect three base station simulators and an AWGN generator to the mobile station as shown in Figure 5.9.1-2.
2. For each band class that the mobile station supports, configure the mobile station to operate in that band class and perform steps 3 through 12.
3. Configure the base station according to the standard test parameters listed in 5.9.2.
4. Set the base station simulator and AWGN generator output levels according to Table 3.2.2.2-1.

**Table 3.2.2.2-1 Signal Levels for the AFLT Sensitivity Test**

Parameter	Unit	Base Station 1	Base Station 2	Base Station 3
$\bar{I}_{or}/I_{oc}$	dB	0	-15.9	-15.9
$I_{oc}$	dBm/1.23 MHz	-55		
$\frac{\text{Pilot } E_c}{I_0}$	dB	-10.1	-26	-26

Note: The Pilot  $E_c/I_0$  value is calculated from the parameters in the table. It is not a directly settable parameter.

5. Measure and record the time offset between the base stations (see 5.4.2).
6. Repeat Steps 7 through 12.
7. Power up the mobile station.
8. Reset the position location related parameters stored by the mobile station.
9. Initiate a mobile terminated voice call.
10. Initiate a Test Mode 4 session.

1 11. Record the values returned by the mobile station.

2 12. Power down the mobile station.

### 3 3.2.2.3 Minimum Specification

4 The parameters returned by the mobile station shall satisfy the requirements listed in Table  
5 3.2.2.3-1; the confidence level for all  $\sigma_1$ ,  $\sigma_2$  type tests shall be 90% (see also 1.6).

6

7 **Table 3.2.2.3-1 Minimum Specifications for the AFLT Sensitivity Test**

<b>Mobile Station Response</b>	<b>Parameter Field</b>	<b>Limit Parameter</b>	<b>Limit Value</b>
<i>Provide MS Information</i>	N/A	$T_1$	750 ms
<i>Provide Pilot Phase Measurement</i>	PILOT_PN_PHASE	$N$	3
		$T_2$	8 s
		PNPHASE <sub>1</sub>	5/16 PN chips
		PNPHASE <sub>2</sub>	9/16 PN chips
	TOTAL_RX_PWR	RXPWR <sub>1</sub>	10 dBm/1.23 MHz
		RXPWR <sub>1</sub>	12 dBm/1.23 MHz
	REF_PILOT_STRENGTH	REFPS <sub>1</sub>	2.5 dB
		REFPS <sub>1</sub>	3.5 dB
	PILOT_STRENGTH	PS <sub>1</sub>	4.5 dB
		PS <sub>1</sub>	8 dB
RMS_ERR_PHASE	$R_1$	0	
	$R_2$	4	
<i>Provide Location Response</i>	LAT	$N$	1
		$T_2$	8 s
	LONG	LATLONG <sub>1</sub>	90 m
		LATLONG <sub>2</sub>	180 m

8

### 9 **3.3 AFLT Protocol Tests**

10 The protocol tests presented in this section shall be performed if the tests listed in 2.2 are  
11 not performed.

### 3.3.1 AFLT Position Location Session on the Paging Channel Test

#### 3.3.1.1 Definition

The purpose of this test is to determine the mobile station's capability to operate in a mode where the base station initiates a position location session on the Paging Channel.

#### 3.3.1.2 Method of Measurement

1. Connect three base station simulators to the mobile station as shown in Figure 5.9.1-2.
2. Configure the mobile station to operate in a band class it supports.
3. Configure the base station according to the standard test parameters listed in 5.9.2.
4. Set the base station simulator output levels according to Table 3.3.1.2-1.

**Table 3.3.1.2-1 Signal Levels for the AFLT Protocol Tests**

Parameter	Unit	Channel 1	Channel 2	Channel 3
$\hat{I}_{or}$	dBm/1.23 MHz	-55	-58	-58
$\frac{\text{Pilot } E_c}{I_0}$	dB	-10	-13	-13

Note: The Pilot  $E_c/I_0$  value is calculated from the parameters in the table. It is not a directly settable parameter.

5. Power up the mobile station.
6. Reset the position location related parameters stored by the mobile station.
7. Initiate a mobile terminated voice call.
8. Initiate a Test Mode 3 session.
9. Record the values returned by the mobile station.
10. Power down the mobile station.

#### 3.3.1.3 Minimum Specification

The mobile station shall respond to base station requests received on the Paging Channel and it shall complete the position location session by returning a *Provide Location Response* message if the mobile station is capable of location computation; or it shall return one or more *Provide Pilot Phase Measurement* messages if it is not capable of location computation. The parameters returned by the mobile station shall satisfy the requirements listed in Table 3.3.1.3-1 (see also 1.6).

1 **Table 3.3.1.3-1 Minimum Specifications for the AFLT Position Location Session on the**  
 2 **Paging Channel Test**

<b>Mobile Station Response</b>	<b>Parameter Field</b>	<b>Limit Parameter</b>	<b>Limit Value</b>
<i>Provide Pilot Phase Measurement</i>	PILOT_PN_PHASE	<i>N</i>	2
		<i>T<sub>2</sub></i>	16 s
<i>Provide Location Response</i>	LAT LONG	<i>N</i>	1
		<i>T<sub>2</sub></i>	16 s

3  
 4 3.3.2 Mobile Station Originated AFLT Position Location Session Test

5 These tests shall only be applied to mobile stations that support mobile station originated  
 6 position location sessions.

7 3.3.2.1 Mobile Station Originated AFLT Position Location Session on the Access Channel

8 3.3.2.1.1 Definition

9 This test shall be only applied to mobile stations that support position location session  
 10 origination on the Access Channel. The purpose of this test is to determine the mobile  
 11 station's capability to operate in a mode where the position location session is originated by  
 12 the mobile station.

13 3.3.2.1.2 Method of Measurement

- 14 1. Connect three base station simulators to the mobile station as shown in Figure 5.9.1-2.
- 15 2. Configure the mobile station to operate in a band class it supports.
- 16 3. Configure the serving base station according to the standard test parameters listed in  
 17 5.9.2.
- 18 4. Set the base station simulator output levels according to Table 3.3.1.2-1.
- 19 5. Power up the mobile station.
- 20 6. Reset the position location related parameters stored by the mobile station.
- 21 7. Initiate a Test Mode 1 session.
- 22 8. Record the values returned by the mobile station or the computed location stored in the  
 23 mobile station.
- 24 9. Power down the mobile station.

### 3.3.2.1.3 Minimum Specification

The mobile station shall complete the position location session by returning one or more *Provide Pilot Phase Measurement* messages if it is not capable of location computation or by computing its own location otherwise.

Note, if the mobile station is capable of location computation, it may return neither pilot phase measurement values nor the calculated position during this test. In this case the calculated position shall be retrieved from the mobile station by other means (for example, through the data port).

The parameters returned or computed by the mobile station shall satisfy the requirements listed in Table 3.3.2.1.3-1 (see also 1.6).

Note, time limit  $T_2$  applies to the measurement time period that starts when the position location session is invoked at the mobile station.

**Table 3.3.2.1.3-1 Minimum Specifications for the Mobile Station Originated AFLT Position Location Session Tests**

Mobile Station Response	Parameter Field	Limit Parameter	Limit Value
<i>Provide Pilot Phase Measurement</i>	PILOT_PN_PHASE	$N$	2
		$T_2$	16 s
Computed Mobile Station Location	N/A	$N$	1
		$T_2$	16 s

### 3.3.2.2 Mobile Station Originated Position AFLT Location Session on a Dedicated Channel

#### 3.3.2.2.1 Definition

This test shall only be applied to mobile stations that support position location session origination on a dedicated channel. The purpose of this test is to determine the mobile station's capability to operate in a mode where the position location session is originated by the mobile station.

#### 3.3.2.2.2 Method of Measurement

1. Connect three base station simulators to the mobile station as shown in Figure 5.9.1-2.
2. Configure the mobile station to operate in a band class it supports.
3. Configure the serving base station according to the standard test parameters listed in 5.9.2.
4. Set the base station simulator output levels according to Table 3.3.1.2-1.

- 1 5. Power up the mobile station.
- 2 6. Reset the position location related parameters stored by the mobile station.
- 3 7. Set up a mobile station originated voice call.
- 4 8. Initiate a Test Mode 2 session.
- 5 9. Record the values returned by the mobile station or the computed location stored in the
- 6 mobile station.
- 7 10. Power down the mobile station.

#### 8 3.3.2.2.3 Minimum Specification

9 The mobile station shall complete the position location session by returning one or more  
10 *Provide Pilot Phase Measurement* messages if it is not capable of location computation or by  
11 computing its own location otherwise.

12 Note, if the mobile station is capable of location computation, it may return neither pilot  
13 phase measurement values nor the calculated position during this test. In this case the  
14 calculated position shall be retrieved from the mobile station by other means (for example,  
15 through the data port).

16 The parameters returned or computed by the mobile station shall satisfy the requirements  
17 listed in Table 3.3.2.1.3-1 (see also 1.6).

18 Note, time limit  $T_2$  applies to the measurement time period that starts at invoking the  
19 position location session at the mobile station.

20



## 4 HYBRID MINIMUM SPECIFICATIONS

The tests described in this section shall be performed for hybrid capable mobile stations. Hybrid capable mobile stations shall also meet all requirements listed in 2 and 3.

### 4.1 General Comments on Hybrid Tests

The following comments apply to all hybrid test cases:

- Hybrid tests are described as using base stations or base station simulators, but it is understood that equivalent pilot generators for the non-serving base stations may be used.
- In the hybrid tests, either three base stations (base station 1, 2 and 3) or two base stations are used. In the case of two base stations being used, the base station configuration is the same as in the three base station case but base station 3 is omitted.
- No handoff scenario tests are included; the serving base station is always base station 1.
- For all hybrid tests, base station 1 pilot PN offset is  $P_0$ , base station 2 pilot PN offset is  $P_1$  and base station 3 PN offset is  $P_2$ , where  $P_0$ ,  $P_1$  and  $P_2$  are arbitrary values satisfying the requirements listed in 5.9.2. Furthermore,  $P_0$  corresponds to PILOT\_PN in the *Sync Channel Message* and to REF\_PN in the PDE simulator GPS assistance messages, while  $P_1$  and  $P_2$  correspond to the appropriate values in both the *General Neighbor List Message* (see Table 5.9.2-4) and the PDE simulator *Provide Base Station Almanac* message.
- For all hybrid tests, the simulated locations (not the actual physical locations) of the mobile station and the base stations are as follows: The three base stations form an equilateral triangle with the mobile station being at the geometric center of the triangle. Each base station is at a distance of 5 km from every other base station; thus, the mobile station is at a distance of  $5/\sqrt{3}$  km from each base station. Base station 1 is due north from the mobile station, and base station 2 is southeast from the mobile station. See Annex B for detailed location data. Note, because of the above configuration, the true time offset between the base stations' signals observed at the mobile station's location should be zero.
- The inconsistency between the assumed mobile station to base station distance as specified above and the physical base station to mobile station signal propagation delay is compensated by setting the TIME\_CRRECTION\_REF and TIME\_CORRECTION fields in the *Provide Base Station Almanac* message to the appropriate values.
- In this section where the mobile station is capable of location computation, the alternative base station to base station and base station to GPS simulator synchronization method described in 5.4.2 and 5.6 shall not be used. Instead, the stricter requirement of maintaining less than 30 ns timing offset shall be met (see 5.4.2 and 5.6).

- 1     ▪ The limit values for each measurement parameter represent an interpretation of the
- 2         returned values with the units stated and are not the actual returned binary values.

## 3     **4.2 Hybrid Performance Specifications**

4     The measurement performance specifications described in this section set a minimum  
5     acceptable level of accuracy for the hybrid measurements returned by the mobile station  
6     under various test conditions.

### 7     4.2.1 One Base Station + Three Satellites Hybrid Test

#### 8     4.2.1.1 Definition

9     This test shall only be applied to mobile stations that are capable of location computation.  
10    The purpose of this test is to determine the mobile station's capability to compute location  
11    based on only three visible satellites. The GPS simulator shall provide high SNR signals  
12    representing three satellites with HDOP less than 3.8. Note that the GPS assistance  
13    provided by the serving base station is not limited to three satellites during this test. A  
14    sequence of independent measurements is carried out. In each measurement, the mobile  
15    station shall return a *Provide Location Response* message. The test may be stopped when  
16    the required confidence levels are met for all tested parameters.

#### 17    4.2.1.2 Method of Measurement

- 18    1. Connect a base station simulator and a GPS simulator to the mobile station as shown in  
19       Figure 5.9.1-3.
- 20    2. Configure the mobile station to operate in a band class it supports.
- 21    3. Configure the base station according to the standard test parameters listed in 5.9.2.
- 22    4. Configure the GPS simulator according to the standard test parameters listed in Annex  
23       B.
- 24    5. Set the GPS simulator output levels according to Table 4.2.1.2-1. Satellites not listed in  
25       Table 4.2.1.2-1 shall not be simulated.

26  
27     **Table 4.2.1.2-1 Satellite Signal Levels for the One Base Station + Three Satellites**  
28             **Hybrid Test**

<b>Satellite PRN Number</b>	<b>Signal Level (dBm)</b>	<b>C/N<sub>0</sub> (dB-Hz)</b>
14, 17, 31	-144	30

- 29  
30    6. Repeat Steps 7 through 12.
- 31    7. Power up the mobile station.

- 1 8. Reset previous measurements, computed positions, values calculated during previous
- 2 fixes and GPS system time.
- 3 9. Initiate a mobile terminated voice call.
- 4 10. Initiate a Test Mode 4 session.
- 5 11. Record the values returned by the mobile station.
- 6 12. Power down the mobile station.

7 4.2.1.3 Minimum Specification

8 The parameters returned by the mobile station shall satisfy the requirements listed in Table  
 9 4.2.1.3-1; the confidence level for the  $\sigma_1$ ,  $\sigma_2$  type tests shall be 90% (see also 1.6).

10

11 **Table 4.2.1.3-1 Minimum Specifications for the One Base Station + Three Satellites**  
 12 **Hybrid Test**

<b>Mobile Station Response</b>	<b>Parameter Field</b>	<b>Limit Parameter</b>	<b>Limit Value</b>
<i>Provide MS Information</i>	N/A	$T_1$	750 ms
<i>Provide Location Response</i>	LAT	$N$	1
	LONG	$T_2$	16 s
		LATLONG <sub>1</sub>	100 m
		LATLONG <sub>2</sub>	175 m

13

14 4.2.2 Two Base Stations + One Satellite Hybrid Test

15 4.2.2.1 Definition

16 This test shall only be applied to mobile stations that are capable of location computation.  
 17 The purpose of this test is to determine the mobile station’s capability to obtain a position  
 18 solution by using altitude aiding and observing signals from two base stations and one  
 19 satellite. The base station simulators shall provide high SNR signals representing two base  
 20 stations. The GPS simulator shall provide high SNR signal representing one satellite, which  
 21 is located approximately at elevation equal to 45° and azimuth equal to -120°. Note that  
 22 the GPS assistance provided by the serving base station is not limited to one satellite during  
 23 this test. A sequence of independent measurements is carried out. In each measurement,  
 24 the mobile station shall return a *Provide Location Response* message. The test may be  
 25 stopped when the required confidence levels are met for all tested parameters.

26 4.2.2.2 Method of Measurement

- 27 1. Connect two base station simulators, a GPS simulator and an AWGN generator to the
- 28 mobile station as shown in Figure 5.9.1-3.

2. Configure the mobile station to operate in a band class it supports.
3. Configure the serving base station according to the standard test parameters listed in 5.9.2.
4. Configure the GPS simulator according to the standard test parameters listed in Annex B.
5. Set the base station simulator and AWGN generator output levels according to Table 4.2.2.2-1.

**Table 4.2.2.2-1 Base Station Signal Levels for the Two Base Stations + One Satellite Hybrid Test**

Parameter	Unit	Base Station 1	Base Station 2
$\hat{I}_{or}/I_{oc}$	dB	5	2
$I_{oc}$	dBm/1.23 MHz	-55	
$\frac{\text{Pilot } E_c}{I_0}$	dB	-9.6	-12.6

Note: The Pilot  $E_c/I_0$  value is calculated from the parameters in the table. It is not a directly settable parameter.

6. Set the GPS simulator output level according to Table 4.2.2.2-2. Satellites not listed in Table 4.2.2.2-2 shall not be simulated.

**Table 4.2.2.2-2 Satellite Signal Level for the Two Base Stations + One Satellite Hybrid Test**

Satellite PRN Number	Signal Level (dBm)	C/N <sub>0</sub> (dB-Hz)
3	-144	30

7. Repeat Steps 8 through 13.
8. Power up the mobile station.
9. Reset previous measurements, computed positions, values calculated during previous fixes and GPS system time.
10. Initiate a mobile terminated voice call.
11. Initiate a Test Mode 4 session.
12. Record the values returned by the mobile station.

1 13. Power down the mobile station.

2 4.2.2.3 Minimum Specification

3 The parameters returned by the mobile station shall satisfy the requirements listed in Table  
4 4.2.2.3-1; the confidence level for the  $\sigma_1$ ,  $\sigma_2$  type tests shall be 90% (see also 1.6).

5

6 **Table 4.2.2.3-1 Minimum Specifications for the Two Base Stations + One Satellite**  
7 **Hybrid Test**

<b>Mobile Station Response</b>	<b>Parameter Field</b>	<b>Limit Parameter</b>	<b>Limit Value</b>
<i>Provide MS Information</i>	N/A	$T_1$	750 ms
<i>Provide Location Response</i>	LAT LONG	$N$	1
		$T_2$	16 s
		LATLONG <sub>1</sub>	100 m
		LATLONG <sub>2</sub>	175 m

8



## 5 STANDARD TEST CONDITIONS

### 5.1 Standard Equipment

#### 5.1.1 Basic Equipment

The equipment shall be assembled, and any necessary adjustments shall be made in accordance with the manufacturer's instructions for the mode of operation required. When alternative modes are available, the equipment shall be assembled and adjusted in accordance with the relevant instructions. A complete series of measurements shall be made for each mode of operation.

#### 5.1.2 Associated Equipment

The mobile station equipment may include associated equipment during tests, provided that the associated equipment is normally used in the operation of the equipment under test. For mobile station equipment, this may include power supplies, handsets, cradles, charging stands, control cables and battery cables.

### 5.2 Standard Environmental Test Conditions

Measurements under standard atmospheric conditions shall be carried out under any combination of the following conditions:

- Temperature: +15°C to +35°C
- Relative humidity: 45% to 75%
- Air pressure: 86,000 Pa to 106,000 Pa (860 mbar to 1060 mbar)

If desired, the results of the measurements can be corrected by calculation to the standard reference temperature of 25°C and by the standard reference air pressure of 101,300 Pa (1013 mbar).

The values of noise spectral density presented in this Specification are valid for +17°C, 290 K. If testing is done at any other temperature, the value of the noise spectral density,  $N_0$ , should be scaled according to the following formula:  $N_0 = k \times T$  where  $k$  is the Boltzman constant,  $k = 1.380658 \times 10^{-23}$  J/K, and  $T$  is the room temperature expressed in units of Kelvin.

### 5.3 Standard Conditions for the Primary Power Supply

#### 5.3.1 General Requirements

The standard test voltages shall be those specified by the manufacturer, or an equivalent type that duplicates the voltage, impedance, and ampere-hours (if relevant for the measurement) of the recommended supply.

#### 5.3.2 Standard DC Test Voltage from Accumulator Batteries

The standard (or nominal) DC test voltage specified by the manufacturer shall be equal to the standard test voltage of the type of accumulator to be used, multiplied by the number of

1 cells, minus an average DC power cable loss value that the manufacturer determines as  
2 being typical (or applicable) for a given installation. Since accumulator batteries may, or  
3 may not, be under charge, or may be in a state of discharge when the equipment is being  
4 operated, the manufacturer shall also test the equipment at anticipated voltage extremes  
5 above and below the standard voltage. The test voltages shall not deviate from the stated  
6 values by more than  $\pm 2\%$  during a series of measurements carried out as part of a single  
7 test on the same equipment.

### 8 5.3.3 Standard AC Voltage and Frequency

9 For equipment that operates from the AC mains, the standard AC test voltage shall be equal  
10 to the nominal voltage specified by the manufacturer. If the equipment is provided with  
11 different input taps, the one designated "nominal" shall be used. The standard test  
12 frequency and the test voltage shall not deviate from their nominal values by more than  
13  $\pm 2\%$ .

14 The equipment shall operate without degradation, with input voltage variations of up to  
15  $\pm 10\%$ , and shall maintain its specified transmitter frequency stability for input voltage  
16 variations of up to  $\pm 15\%$ . The frequency range over which the equipment is to operate shall  
17 be specified by the manufacturer.

## 18 5.4 Standard CDMA Test Equipment

### 19 5.4.1 Base Station Simulator Equipment

#### 20 5.4.1.1 Transmitter Equipment

21 The base station transmitter shall be capable of generating the following channels at the  
22 specified output power, relative to the total power:

- 23     ▪ Pilot Channel: -5 dB to -10 dB.
- 24     ▪ Sync Channel: -7 dB to -20 dB.
- 25     ▪ Paging Channel: -7 dB to -20 dB.
- 26     ▪ Traffic Channel: -7 dB to -20 dB or off for full rate power output. Lower rates will  
27         reduce the Traffic Channel power so as to maintain a constant energy per bit.
- 28     ▪ Power Control Subchannel: This is always transmitted at the same power as the full  
29         rate speech bits.
- 30     ▪ OCNS: 0 dB to -6 dB or off. The OCNS may, as an option, be composed of Paging,  
31         Sync or Traffic Channels, all operating on different Walsh channels than the  
32         channel(s) being used for test.

33 In addition, the base station transmitter shall meet the following requirements:

- 34     ▪ Frequency range: base station frequencies as specified in [8]
- 35     ▪ Frequency accuracy:  $\pm 0.2$  ppm
- 36     ▪ Frequency resolution: 10 Hz

- 1     ▪ Code phase offset resolution: 100 ns
- 2     ▪ Code phase offset accuracy (referenced to the even second output):  $\pm 20$  ns
- 3     ▪ Output range: -40 dBm/1.23 MHz to -110 dBm/1.23 MHz
- 4     ▪ Amplitude resolution: 1 dB for all channels
- 5     ▪ Output accuracy (relative levels between any two channels):  $\pm 1$  dB
- 6     ▪ Absolute output accuracy:  $\pm 2.0$  dB
- 7     ▪ Minimum waveform quality factor ( $\rho$ ): greater than 0.966 (excess power is less than
- 8       0.15 dB)
- 9     ▪ Source VSWR: 2.0:1

#### 10 Forward Link Power Control:

- 11     ▪ When Forward Link Power Control is used, the latency shall be less than 2 power
- 12       control groups between the end of the power control group with an active power
- 13       control bit and the corresponding change in power in the base station simulator.
- 14     ▪ When Forward Link Power Control is used, the OCNS shall be adjusted to maintain
- 15       constant base station power. The OCNS adjustments should be made in the same
- 16       power control group as the response to Power Control Bits and shall occur no more
- 17       than one power control group later than the response to Power Control Bits.

#### 18 5.4.1.2 Receiver Equipment

19 Input Range -50 dBm to +40 dBm. External attenuators or amplifiers or both may be used  
20 to meet these power requirements, and may be considered as part of the equipment.

#### 21 5.4.1.3 Protocol Support

22 The base station shall be capable of supplying the protocols required by this document.

#### 23 5.4.1.4 Timing Signals

24 The base station shall provide the following system timing signals, referenced to the base  
25 station antenna port for use as triggers by other measurement equipment:

- 26     ▪ 10 MHz frequency reference
- 27     ▪ Even second time mark

28 The base station shall provide signals synchronized to the following event:

- 29     ▪ Start of reference clock at preset system time
- 30     ▪ Start of power control bit sequence

#### 31 5.4.1.5 Base Station *Data Burst Message* Transport Capability

32 The serving base station shall be capable of transporting *Data Burst Messages* in both  
33 directions between an auxiliary test equipment connected to it (for example, the PDE  
34 simulator described in 5.8) and the mobile station.

1 The serving base station shall meet the following requirements:

- 2     ▪ The serving base station shall provide a transparent connection between the auxiliary  
3       test equipment and the mobile station.
- 4     ▪ The serving base station shall be capable of sending *Data Burst Messages* on both the  
5       paging channel and the forward link traffic channel and receiving *Data Burst*  
6       *Messages* on both the access channel and the reverse link traffic channel.
- 7     ▪ The latency between the end of the reception of a *Data Burst Message* and the  
8       transmission of the end of the same *Data Burst Message* by the serving base station  
9       shall be less than 1 s.

#### 10 5.4.2 Synchronization of Base Stations

11 If more than one base station is used in a test and the base stations don't share an internal  
12 timing source, then synchronization of the base stations must be achieved by external  
13 means.

14 The synchronization may be achieved by using two separate connections:

- 15 1. For frequency synchronization, the serving base station's 10 MHz reference signal  
16     should be used.
- 17 2. For system time synchronization, the serving base station's even second timing signal  
18     should be used.

19 The synchronization between the base stations shall meet the following minimum  
20 requirements:

- 21     ▪ Frequency offset between the base station carriers shall be less than  $\pm 0.02$  ppm.
- 22     ▪ Phase offset between the base station carriers shall be constant within  $\pm 0.2$  radians  
23       throughout the test.
- 24     ▪ The timing offset between the base stations (i.e. system time modified by the code  
25       phase offset adjustments), referenced to the mobile station's antenna input, shall be  
26       less than  $\pm 30$  ns.

27 If the requirement regarding the timing offset between the base stations is not met, the use  
28 the following method is permissible, unless specified otherwise in a test:

- 29 1. Connect a clock/counter to the two base stations' even second pulse output, so that the  
30     clock measures the time difference between the active edges of the even second pulses  
31     outputted by the two base stations. The clock/counter may use an internal time  
32     reference or, optionally, derive its internal time reference from one of the base stations'  
33     10 MHz signal.
- 34 2. At the beginning of the measurement, record the measured time difference.
- 35 3. Before evaluation, correct the pilot phase measurements with the measured offset.

36 When using the method described above, the achieved synchronization shall meet the  
37 following minimum requirements:

- 1     ▪ The timing offset between the base stations' even second pulse output shall be less  
2       than  $\pm 1 \mu\text{s}$ .
- 3     ▪ The timing offset between the base stations' even second pulse output shall be  
4       measured with accuracy better than  $\pm 10 \text{ ns}$ .

### 5 5.4.3 CDMA Pilot Generator Equipment

6 When a particular test requires the use of more than one base station, the non-serving base  
7 stations may be simulated by using CDMA pilot generators instead of base station  
8 simulators. In this case, if the AWGN generator is also connected (i.e. for all tests other  
9 than protocol tests), then the AWGN generator's output signal level is adjusted so that the  
10 specified Pilot  $E_C/I_0$  values are maintained for all pilots.

#### 11 5.4.3.1 Transmit Equipment

12 The requirements for the CDMA pilot generator transmit equipment shall be the same as  
13 the requirements relevant to the pilot signal in 5.4.1.1.

#### 14 5.4.3.2 Timing Signals

15 The CDMA pilot generator shall accept the following system timing signals, referenced to  
16 the CDMA pilot generator antenna port:

- 17     ▪ 10 MHz frequency reference
- 18     ▪ Even-second time mark

19 The CDMA pilot generator shall provide the following timing signal, referenced to the CDMA  
20 station antenna port for use as triggers by other measurement equipment:

- 21     ▪ Even second time mark

#### 22 5.4.3.3 Synchronization of a CDMA Pilot Generator

23 The requirements for the CDMA pilot generator transmit equipment shall be the same as  
24 the requirements relevant to the base station simulator in 5.4.2.

## 25 **5.5 GPS Simulator Equipment**

26 The GPS simulator shall be capable of all of the following:

- 27     ▪ Generate eight independent C/A signals on the L1 frequency.
- 28     ▪ Set accurate satellite positions and timing, based on Ephemeris data input, where all  
29       Ephemeris parameter fields are populated.
- 30     ▪ Set the signal phase dynamically, based on the satellite and user positions, with  
31       added offset derived from ionospheric, tropospheric and group delay models.
- 32     ▪ Simultaneously generate signals representing specified code phase and power level  
33       offsets for a given satellite.
- 34     ▪ Set the user position to be stationary or in motion along a circular trajectory.

- 1     ▪ Modulate the satellite signal with navigation bits with a specified bit stream in a
- 2         manner that is consistent with the simulated GPS system time.
- 3     ▪ Start the simulation at a preset GPS system time, triggered by an external signal.

4 The GPS simulator shall meet the following minimum requirements:

- 5     ▪ Frequency (L1): 1575.42 MHz
- 6     ▪ Frequency accuracy:  $\pm 0.2$  ppm
- 7     ▪ Code phase accuracy (referenced to the 1 PPS output):  $\pm 20$  ns
- 8     ▪ Doppler resolution: 0.5 Hz
- 9     ▪ Doppler accuracy:  $\pm 5$  Hz
- 10    ▪ Output range referenced to the mobile station antenna input: -125 dBm to -147 dBm.
- 11         Note that it may be necessary to utilize attenuators or other RF elements to achieve
- 12         the required GPS signal levels at the mobile station antenna input. In all cases, the
- 13         GPS L1 band noise power spectral density at the mobile station antenna input will be
- 14         -174 dBm/Hz, which is equivalent to room temperature thermal noise.
- 15    ▪ Amplitude resolution: 1 dB for all channels
- 16    ▪ Output accuracy (relative levels between any two channels):  $\pm 1.0$  dB
- 17    ▪ Absolute output accuracy:  $\pm 2.0$  dB
- 18    ▪ Source VSWR: 2.0:1

19 The GPS simulator shall accept the following system timing signals, referenced to the GPS

20 antenna port:

- 21    ▪ 10 MHz frequency reference
- 22    ▪ Even-second time mark

23 The GPS simulator shall provide the following timing signal, referenced to the CDMA station

24 antenna port for use as triggers by other measurement equipment:

- 25    ▪ 1 PPS signal

## 26 **5.6 Synchronization of the Serving Base Station and the GPS Simulator**

27 Time synchronization between the serving base station and the GPS simulator is critical in

28 some cases, since many MS implementations assume acquiring GPS system time from the

29 CDMA network.

30 The synchronization may be achieved by using two separate connections:

- 31 1. For frequency synchronization, the serving base station's 10 MHz reference signal
- 32     should be used. Optionally, the direction of the signal may be reversed so that the clock
- 33     with higher precision is configured as the source.
- 34 2. For system time synchronization, the serving base station's even second signal should
- 35     be used. Both the base station and the GPS simulator will be preset to start at the same
- 36     predetermined reference time value at the occurrence of the first even second pulse.

1        Optionally, the direction of the even second (or 1 PPS) signal may be reversed, so that  
2        the GPS simulator's timing signal serves as the source.

3        The synchronization between the base station and the GPS simulator shall meet the  
4        following minimum requirements:

- 5        ▪ Frequency offset between the base station and the GPS simulator carriers (after  
6        frequency division to match the lower of the two frequencies) shall be less than  $\pm 0.02$   
7        ppm.
- 8        ▪ Phase offset between the base station and the GPS simulator carriers (after frequency  
9        division to match the lower of the two frequencies) shall be constant within  $\pm 0.2$   
10        radians throughout the test.
- 11        ▪ The timing offset between the serving base station and the GPS simulator (i.e. the  
12        offset between CDMA and GPS system time), referenced to the mobile station's  
13        antenna input, shall be less than  $\pm 30$  ns.

14        If the requirement regarding the timing offset is not met, the use the following method is  
15        permissible, unless specified otherwise in a test:

- 16        1. Connect a clock/counter to the serving base station's even second pulse output and the  
17        GPS simulator's 1 PPS output, so that the clock measures the time difference between  
18        the active edges of the even second and the 1 PPS pulses. The clock/counter can use  
19        an internal time reference or, optionally, derive the internal time from the serving base  
20        station's or the GPS simulator's 10 MHz signal.
- 21        2. At the beginning of the measurement, record the measured time difference.
- 22        3. Before evaluation, correct the pseudorange measurements or the clock bias returned by  
23        the mobile station with the measured offsets.

24        When using the method described above, the achieved synchronization shall meet the  
25        following minimum requirements:

- 26        ▪ The timing offset between the even second pulse and the 1 PPS pulse shall be less  
27        than  $\pm 10$   $\mu$ s.
- 28        ▪ The timing offset between the even second signal and the 1 PPS signal shall be  
29        measured with accuracy better than  $\pm 10$  ns.

## 30        **5.7    AWGN Generator Equipment**

31        The AWGN generator shall meet the following minimum performance requirements:

- 32        ▪ Minimum bandwidth: 1.8 MHz for CDMA Spreading Rate 1. For the definition of  
33        Spreading Rate 1, see [8].

- 1     ▪ The frequency ranges<sup>7</sup> are listed in Table 5.7-1.
- 2     ▪ The noise power spectral density level in the GPS L1 band shall not exceed -174
- 3       dBm/Hz at the mobile station antenna input.

4

5                   **Table 5.7-1 AWGN Generator Frequency Ranges**

Band Class	Frequency Range (MHz)
0	864 to 899
1	1925 to 1985
2	912 to 965
3	827 to 875
4	1835 to 1875
5	416 to 499

- 6
- 7     • Frequency resolution: 10 kHz.
  - 8     • Output accuracy:  $\pm 2$  dB for outputs greater than or equal to -80 dBm/1.23 MHz.
  - 9     • Amplitude resolution: 0.25 dB.
  - 10    • Output range: -40 dBm/1.23 MHz to -95 dBm/1.23 MHz.
  - 11    • The AWGN generator shall be uncorrelated to the ideal CDMA transmitter signals.

## 12    **5.8 PDE Simulator Equipment**

13    The PDE simulator equipment provides a uniform network assistance environment for every  
14    mobile station under test. Optionally, parts or all of the measurement data evaluation may  
15    also be carried out by the PDE simulator equipment.

16    The PDE simulator shall be capable to transmit and receive *Data Burst Messages* to and  
17    from the serving base station.

18    The PDE simulator shall recognize requests from the MS and shall appropriately respond to  
19    them. For this purpose, the PDE simulator shall be able to parse the received messages,  
20    extract the REQ\_TYPE field and the COORD\_TYPE field if REQ\_TYPE = '0110' (Request GPS  
21    Location Assistance) and determine the time-of-arrival of the messages. The PDE simulator  
22    response will be solely determined by these three values, i.e. by the REQ\_TYPE,

---

<sup>7</sup> The frequency ranges are based on covering the receive band and frequencies as great as 5 MHz outside the band.

1 COORD\_TYPE and time-of-arrival of the request. These three values shall serve as indices  
2 into an array that stores all the PDE simulator responses.

3 The PDE simulator shall be capable of recording time-of-arrival of *Data Burst Messages*  
4 sent by the mobile station. The PDE simulator shall also be capable of recording mobile  
5 station response time, measured from the transmission of the end of the *Data Burst*  
6 *Message* containing the PDE request element to the reception of the end of the *Data Burst*  
7 *Message* containing the last part of the corresponding mobile station response element.

8 The PDE simulator shall meet the following minimum requirements:

- 9     ▪ The PDE simulator shall support messages corresponding to all PDE capabilities
- 10    ▪ Maximum Response time (measured from receipt of mobile station request): 200 ms
- 11    ▪ Internal Time accuracy (referenced to base station system time):  $\pm 2$  s
- 12    ▪ Maximal Internal clock drift:  $10^{-4}$  s/s

13 The PDE simulator shall accept the following timing signal:

- 14    ▪ Even-second time mark.
- 15    ▪ Trigger representing the start of the power control bit sequence.

#### 16 5.8.1 PDE Simulator Responses

17 The PDE simulator responses are presented in Annex D. In Annex A, a normative  
18 description is given of the method of generating the PDE simulator responses.

#### 19 5.8.2 *Position Determination Data Message* Call Flows

20 The PDE simulator shall adhere to the following call flows, based on the utilized Position  
21 Location Test Mode (see 1.4):

- 22 1. Position Location Test Mode 1: The PDE simulator shall not send unsolicited response  
23 messages. The PDE simulator shall send solicited response messages to all requests  
24 received from the mobile station, according to 5.8.1, within the maximal response time  
25 specified in 5.8. An example of a successful Test Mode 1 call flow is shown in Figure  
26 5.8.2-1.
- 27 2. Position Location Test Mode 2: The PDE simulator shall not send unsolicited response  
28 messages. The PDE simulator shall send solicited response messages to all requests  
29 received from the mobile station, according to 5.8.1, within the maximal response time  
30 specified in 5.8. An example of a successful Test Mode 2 call flow is shown in Figure  
31 5.8.2-1.
- 32 3. Position Location Test Mode 3: The PDE simulator shall initiate a position location  
33 session by sending a *Position Determination Data Message*, containing a *Request MS*  
34 *Information* message on the Paging Channel. The base station shall use the Paging  
35 Channel until the mobile station requests a dedicated channel. The base station shall  
36 not initiate service negotiation in Position Location Test Mode 3. After receiving the  
37 *Provide MS Information* response element, based on whether the mobile station is

1 capable of location calculation, the PDE simulator shall initiate one of the following two  
2 call flows:

- 3 1. If the mobile station is capable of location calculation (at least one of bits 1-8 of  
4 the LOC\_CALC\_CAP field of the *Provide MS Information* response element is set to  
5 '1'), then the PDE simulator shall send a *Request Location Response* message.  
6 Subsequent to that, the PDE simulator shall not send unsolicited response  
7 messages. The PDE simulator shall send solicited response messages to all  
8 requests received from the mobile station, according to 5.8.1, within the maximal  
9 response time specified in 5.8. An example of a successful call flow is shown in  
10 Figure 5.8.2-2.
- 11 2. If the mobile station is not capable of location calculation (none of bits 1-8 of the  
12 LOC\_CALC\_CAP field of the *Provide MS Information* response element is set to '1'),  
13 then the PDE simulator shall send a *Request Pseudorange Measurement* message,  
14 or a *Request Pilot Phase Measurement* message, or both. Subsequent to that, the  
15 PDE simulator shall not send unsolicited response messages. The PDE simulator  
16 shall send solicited response messages to all requests received from the mobile  
17 station, according to 5.8.1, within the maximal response time specified in 5.8. An  
18 example of a successful call flow is shown in Figure 5.8.2-3.
- 19 4. Position Location Test Mode 4: After the traffic channel assignment is indicated by the  
20 serving base station, the PDE simulator shall initiate a position location session by  
21 sending a *Position Determination Data Message*, containing a *Request MS Information*  
22 message. After receiving the *Provide MS Information* response element, based on  
23 whether the mobile station is capable of location calculation, the PDE simulator shall  
24 initiate one of the following two call flows:
  - 25 3. If the mobile station is capable of location calculation (at least one of bits 1-8 of  
26 the LOC\_CALC\_CAP field of the *Provide MS Information* response element is set to  
27 '1'), then the PDE simulator shall send a *Request Location Response* message.  
28 Subsequent to that, the PDE simulator shall not send unsolicited response  
29 messages. The PDE simulator shall send solicited response messages to all  
30 requests received from the mobile station, according to 5.8.1, within the maximal  
31 response time specified in 5.8. An example of a successful call flow is shown in  
32 Figure 5.8.2-2.
  - 33 4. If the mobile station is not capable of location calculation (none of bits 1-8 of the  
34 LOC\_CALC\_CAP field of the *Provide MS Information* response element is set to '1'),  
35 then the PDE simulator shall send a *Request Pseudorange Measurement* message  
36 or a *Request Pilot Phase Measurement* message or both. Subsequent to that, the  
37 PDE simulator shall not send unsolicited response messages. The PDE simulator  
38 shall send solicited response messages to all requests received from the mobile  
39 station, according to 5.8.1, within the maximal response time specified in 5.8. An  
40 example of a successful call flow is shown in Figure 5.8.2-3.

1

**Figure 5.8.2-1 Example Successful Call Flow for Test Modes 1 and 2**

2

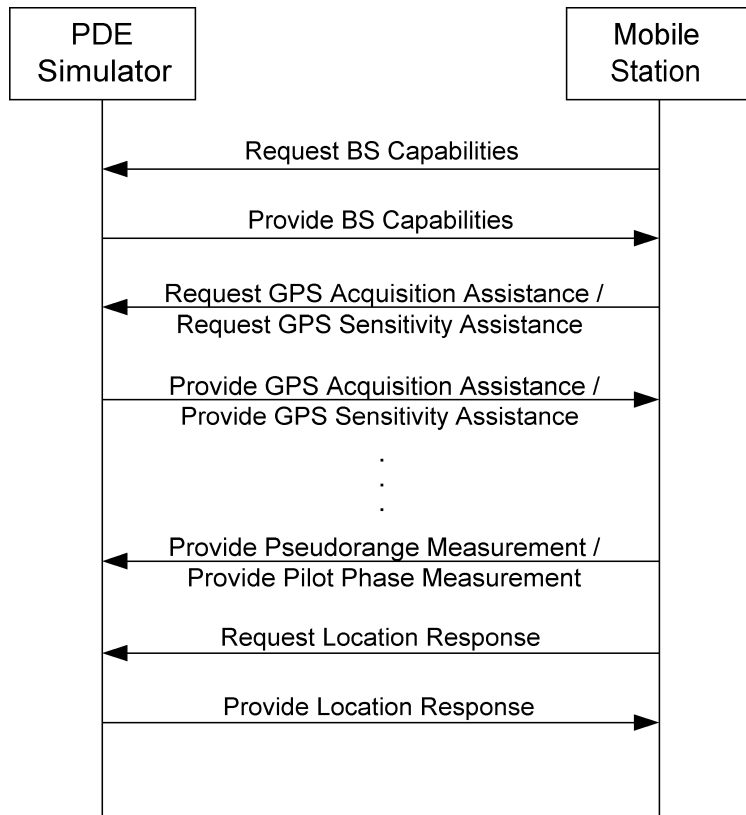

3

1

2

3

4

**Figure 5.8.2-2 Example Successful Call Flow for Test Modes 3 and 4, with Mobile Station that is Capable of Location Calculation**

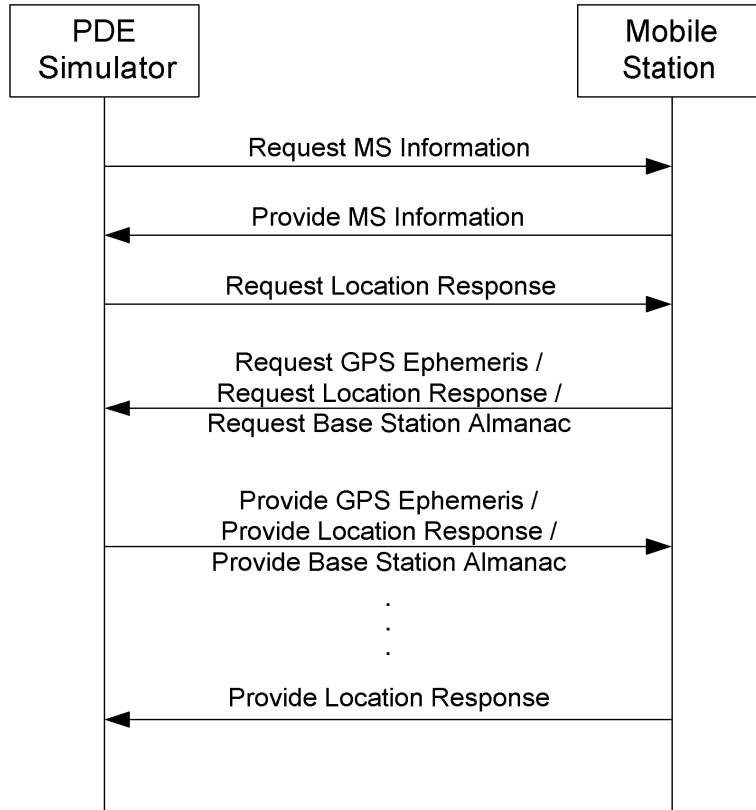

5

1 **Figure 5.8.2-3 Example Successful Call Flow for Test Modes 3 and 4, with Mobile**  
 2 **Station that is not Capable of Location Calculation**

3

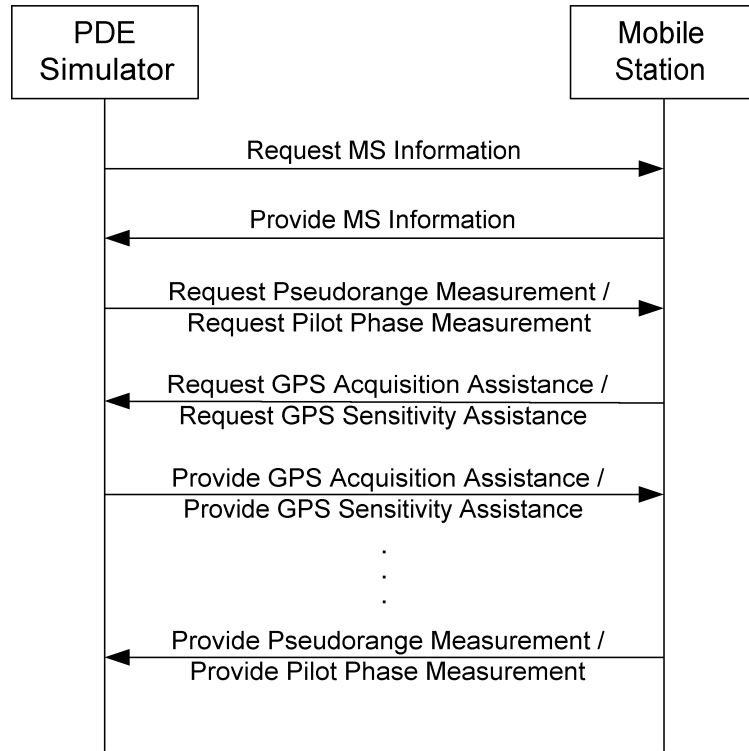

4

5

6 **5.9 Functional System Set-ups**

7 5.9.1 Functional Block Diagrams

8 Figure 5.9.1-1 through Figure 5.9.1-3 show the functional block diagrams of the set-up for  
 9 the GPS, AFLT and Hybrid tests.

10

1

**Figure 5.9.1-1 Functional Set-up for GPS Tests**

2

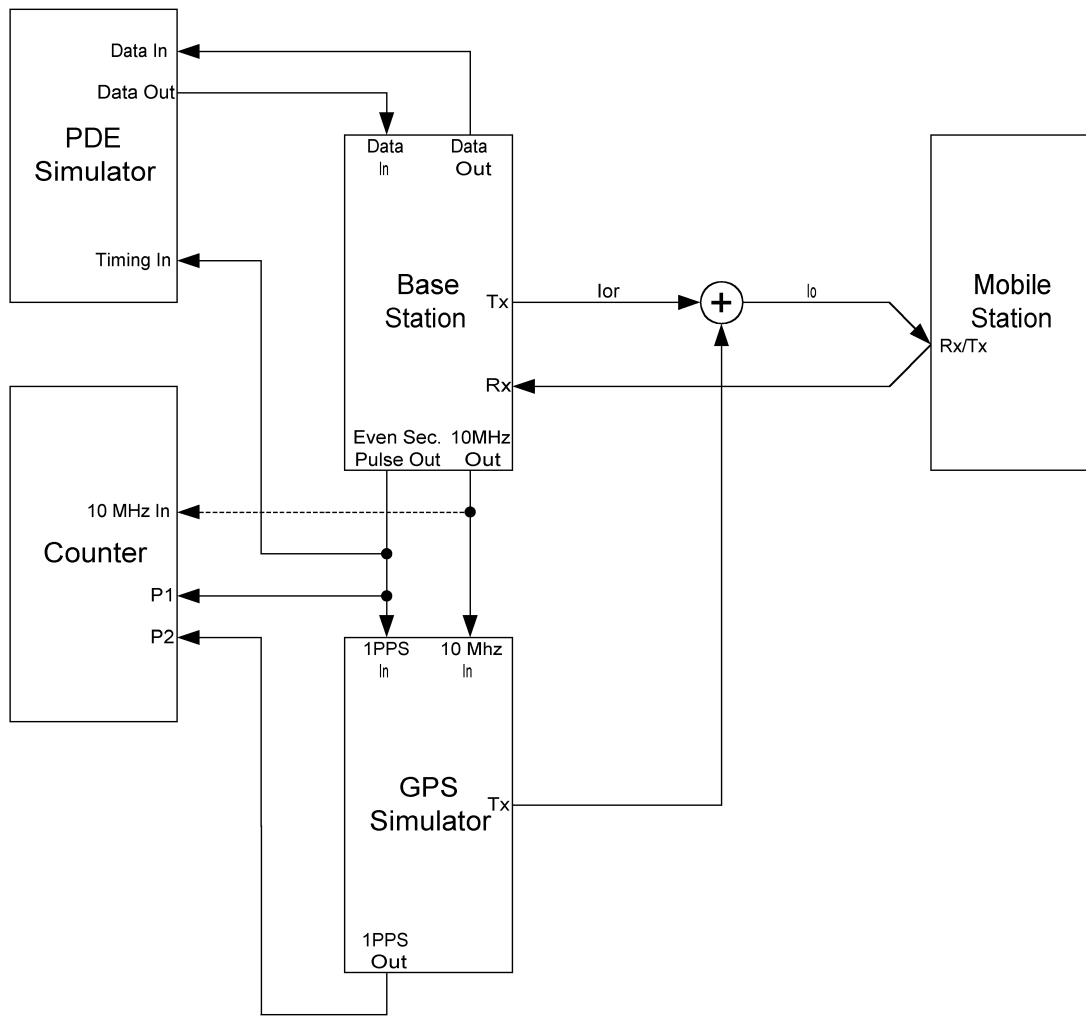

3

4

1

**Figure 5.9.1-2 Functional Set-up for AFLT Tests**

2

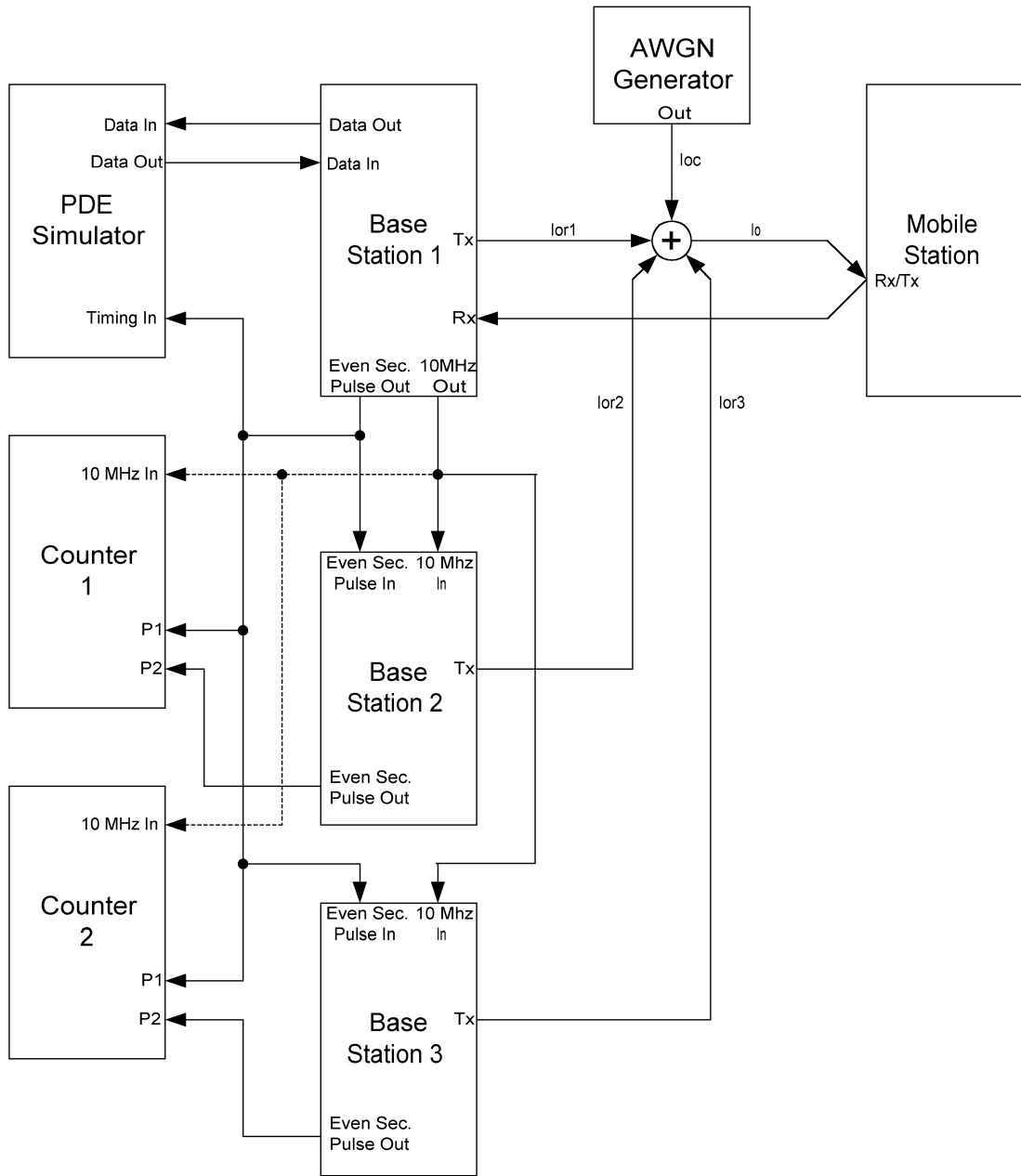

3

4

**Figure 5.9.1-3 Functional Set-up for Hybrid Tests**

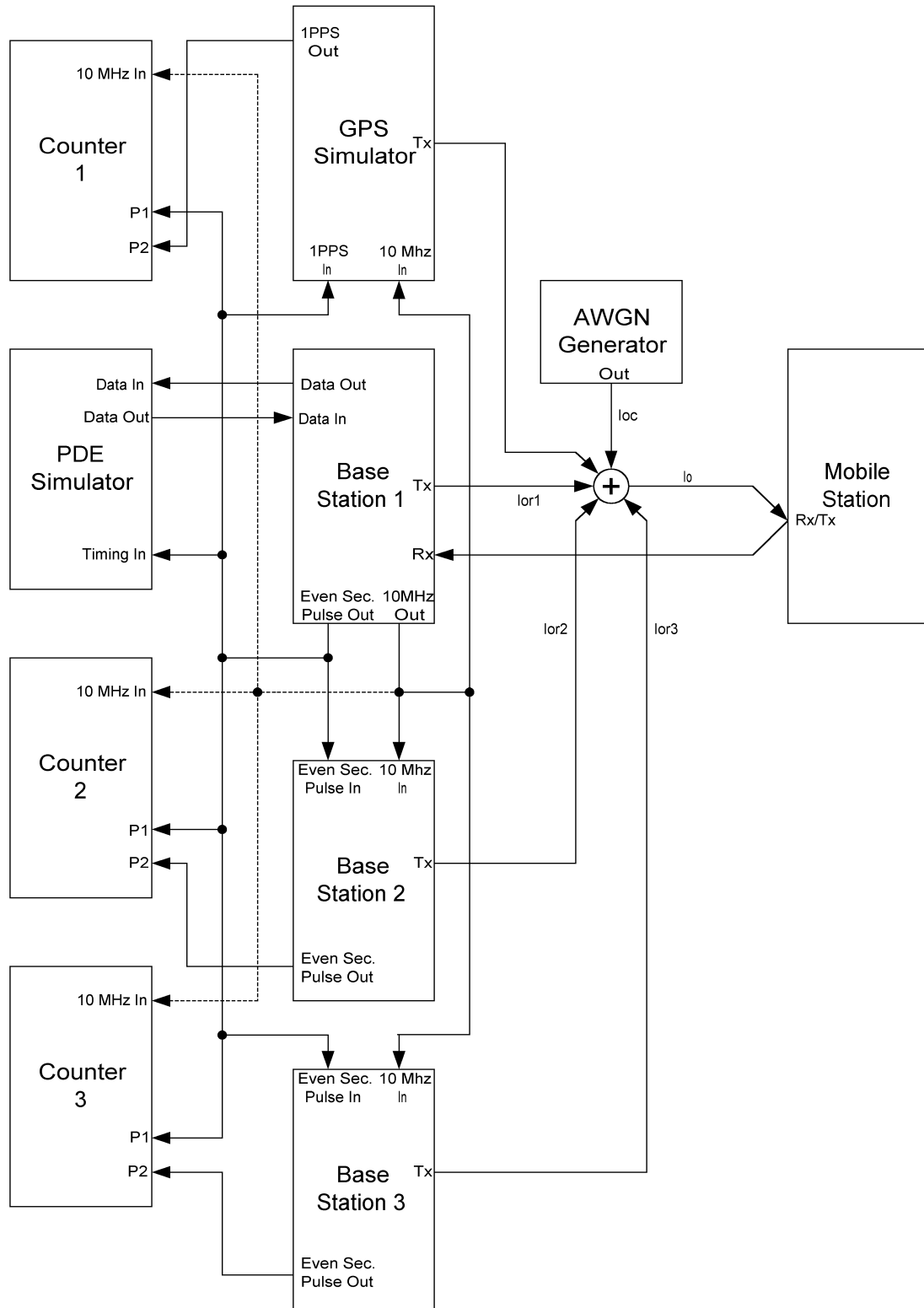

3

4

1 5.9.2 General Comments

2 The following comments apply to all tests:

- 3 1. The Forward CDMA Channel may be comprised of a Pilot Channel, a Sync Channel, a  
4 Paging Channel, a Traffic Channel, and other orthogonal channels (OCNS).
- 5 2. For all base stations, use Pilot  $E_C/I_{OR}$  equal to -7 dB.
- 6 3. For the serving base station, use Traffic  $E_C/I_{OR}$  equal to -15 dB with 9600 bps data rate  
7 (full rate, Rate Set 1).
- 8 4. For the serving base station, use Sync  $E_C/I_{OR}$  equal to -16 dB and Paging  $E_C/I_{OR}$  equal to  
9 -12 dB with Paging Channel data rate at 9600 bps.
- 10 5. Adjust the OCNS gain such that the power ratios ( $E_C/I_{OR}$ ) of all specified forward  
11 channels add up to one.
- 12 6. Pilot PN sequence offset indices are denoted by  $P_i$  ( $i = 0, 1, 2, \dots$ ). The following  
13 assumptions hold unless otherwise specified:
  - 14 •  $0 \leq P_i \leq 511$
  - 15 •  $P_i \neq P_j$  if  $i \neq j$
  - 16 •  $P_i \bmod \text{PILOT\_INC} = 0$

17 The chosen PN-sequence offset values shall be consistent with the parameter settings in  
18 the base station overhead and PDE simulator GPS assistance messages.

- 19 5. Base stations should be configured for normal operation as specified in [8], unless  
20 specifically stated differently in a specific test.
- 21 6. All forward link power control bits from the base station shall be set to '0'.
- 22 7. For a mobile station with an integral antenna, the manufacturer shall provide a  
23 calibrated RF coupling fixture to provide connection to the standard test equipment.  
24 This applies to both the CDMA and GPS antenna connections.
- 25 8. Unless specified otherwise in test procedures, if the mobile station supports turbo  
26 coding on the Reverse Supplemental Channel, the test shall be performed with turbo  
27 coding of the Reverse Supplemental Channel; otherwise, the mobile station shall use  
28 convolutional coding of the Reverse Supplemental Channel.
- 29 9. Overhead message fields should be those needed for normal operation of the base  
30 station, unless stated differently in Table 5.9.2-1 through Table 5.9.2-4 or in a specific  
31 test.

32

**Table 5.9.2-1 Special Field Values of the *System Parameters Message***

<b>Field</b>	<b>Value (Decimal)</b>
REG_PRD	0 (timer-based registration off)
SRCH_WIN_A	8 (60 chips)
SRCH_WIN_N	8 (60 chips)
SRCH_WIN_R	8 (60 chips)
NGHBR_MAX_AGE	0 (minimum amount of Neighbor Set aging)
PWR_THRESH_ENABLE	0 (threshold reporting off)
PWR_PERIOD_ENABLE	0 (periodic reporting off)
T_ADD	28 (-14 dB $E_c/I_0$ )
T_DROP	32 (-16 dB $E_c/I_0$ )
T_COMP	5 (2.5 dB)
T_TDROP	3 (4 sec)

**Table 5.9.2-2 Special Field Value of the *Extended System Parameters Message***

<b>Field</b>	<b>Value (Decimal)</b>
SOFT_SLOPE	0 (0)

**Table 5.9.2-3 Special Field Values of the *Access Parameters Message***

<b>Field</b>	<b>Value (Decimal)</b>
NOM_PWR	0 (0 dB)
NOM_PWR_EXT	0 (0 dB)
INIT_PWR	0 (0 dB)
PWR_STEP	0 (0 dB)
NUM_STEP	4 (5 probes per sequence)

**Table 5.9.2-4 Special Field Values of the *General Neighbor List Message* for the Serving Base Station**

<b>Field</b>	<b>Value (Decimal)</b>
PILOT_INC	1 (64 chips)
NGHBR_SRCH_MODE	0 (no priorities or windows)
NUM_NGHBR	8 (8 neighbors)
NGHBR_CONFIG	0
NGHBR_PN	P <sub>1</sub>
NGHBR_CONFIG	0
NGHBR_PN	P <sub>2</sub>
NGHBR_CONFIG	0
NGHBR_PN	P <sub>3</sub>
NGHBR_CONFIG	0
NGHBR_PN	P <sub>4</sub>
NGHBR_CONFIG	0
NGHBR_PN	P <sub>5</sub>
NGHBR_CONFIG	0
NGHBR_PN	P <sub>6</sub>
NGHBR_CONFIG	0
NGHBR_PN	P <sub>7</sub>
NGHBR_CONFIG	0
NGHBR_PN	P <sub>8</sub>

11. Values of time limits and other constants should be as specified in [7]. Values of some time limits and constants are listed in Table 5.9.2-5 for reference.

1

**Table 5.9.2-5 Time Limit and Constant Values**

<b>Constant</b>	<b>Value</b>	<b>Unit</b>
$N_{1m}$	9	frames
$N_{2m}$	12	frames
$N_{3m}$	2	frames
$N_{11m}$	1	frame
$T_{1b}$	1.28	seconds
$T_{5m}$	5	seconds
$T_{40m}$	3	seconds
$T_{61m}$	0.08	seconds
$T_{72m}$	1	second

2

3

## 1 **Annex A – METHOD OF GENERATING PDE SIMULATOR RESPONSES**

2 This Annex is normative.

### 3 **A.1 General Requirements for *Position Determination Data Message* Origination**

#### 4 A.1.1 *Data Burst Message* Origination

5 The PDE simulator shall comply with the requirements of Section 4.2.2.3.5 of [1]. The PDE  
6 simulator shall limit the *Data Burst Message* size to 200 bytes.

#### 7 A.1.2 *Position Determination Data Message* Origination

8 The PDE simulator shall populate the *Position Determination Data Message* field according  
9 to Section 4.2.4 of [1]. In particular, for Test Modes 1 and 2, the value assignments are  
10 shown in Table A.1.2-1; for Test Modes 3 and 4, with a mobile station that is capable of  
11 position calculation, the value assignments are shown in Table A.1.2-2; and for Test Modes  
12 3 and 4, with a mobile station that is not capable of position calculation, the value  
13 assignments are shown in Table A.1.2-3.

14  
15 **Table A.1.2-1 *Position Determination Data Message* Format for Test Modes 1 and 2**

Field	Value (Binary)
SESS_START	'0'
SESS_END	'0'
SESS_SOURCE	'1'
SESS_TAG	Same as in MS Request
PD_MSG_TYPE	'00000000'
NUM_REQUESTS	'0000'
NUM_RESPONSES	As specified in [1]

The base station shall include NUM\_RESPONSES occurrences of the following record:

RESERVED	'000'
UNSOL_RESP	'0'
RESP_TYPE	Same as in MS Request
RESP_PAR_LEN	As specified in [1]
RESP_PAR_RECORD	As specified in [1]

16

1 **Table A.1.2-2 Position Determination Data Message Format for Test Modes 3 and 4,**  
 2 **with a Mobile Station that is Capable of Position Calculation**

Field	Value (Binary)
SESS_START	'1' in first message, '0' otherwise
SESS_END	'0'
SESS_SOURCE	'0'
SESS_TAG	'00000'
PD_MSG_TYPE	'00000000'
NUM_REQUESTS	'0001' in first message, '0001' in second message, '0000' otherwise
NUM_RESPONSES	'0000' in first message, As specified in [1] otherwise

The base station shall include NUM\_REQUESTS occurrences of the following record:

RESERVED	'0000'
REQ_TYPE	'0010' in first message, '0001' in second message
REQ_PAR_LEN	As specified in [1]
REQ_PAR_RECORD	As specified in [1]

The base station shall include NUM\_RESPONSES occurrences of the following record:

RESERVED	'000'
UNSOL_RESP	'0'
RESP_TYPE	As specified in [1]
RESP_PAR_LEN	As specified in [1]
RESP_PAR_RECORD	As specified in [1]

1 **Table A.1.2-3 Position Determination Data Message Format for Test Modes 3 and 4,**  
 2 **with a Mobile Station that is not Capable of Position Calculation**

Field	Value (Binary)
SESS_START	'1' in first message, '0' otherwise
SESS_END	'0'
SESS_SOURCE	'0'
SESS_TAG	'00000'
PD_MSG_TYPE	'00000000'
NUM_REQUESTS	'0001' in first message, '0001' or '0010' in second message, '0' otherwise
NUM_RESPONSES	'0000' in first message As specified in [1] otherwise

The base station shall include NUM\_REQUESTS occurrences of the following record:

RESERVED	'0000'
REQ_TYPE	'0010' in first message, '0100' or '0101' or both '0100' and '0101' in second message, '0' otherwise
REQ_PAR_LEN	As specified in [1]
REQ_PAR_RECORD	As specified in [1]

The base station shall include NUM\_RESPONSES occurrences of the following record:

RESERVED	'000'
UNSOL_RESP	'0'
RESP_TYPE	As specified in [1]
RESP_PAR_LEN	As specified in [1]
RESP_PAR_RECORD	As specified in [1]

1 A.1.3 *Position Determination Data Message Segmentation*

2 The PDE simulator shall divide messages into parts as necessary in order to meet the  
3 requirement listed in A.1.1. The message segmentation shall be performed according to the  
4 requirements listed in Section 4.2.2.3.3.1 of [1].

5 **A.2 Method of Selecting the PDE Simulator Response Message**

6 The PDE simulator shall respond to requests received from the mobile station by sending  
7 one of the PDE simulator response messages presented in Annex D. The PDE simulator  
8 shall select the response message based on the received REQ\_TYPE and COORD\_TYPE, if  
9 REQ\_TYPE = '0110' (*Request GPS Location Assistance*), and the time-of-arrival of the mobile  
10 station request.

11 A.2.1 PDE Simulator Response Type

12 When responding to a mobile station request, the PDE response type shall be determined by  
13 the received REQ\_TYPE and COORD\_TYPE, if REQ\_TYPE = '0110' (*Request GPS Location*  
14 *Assistance*) as listed in Table A.2.1-1.

15  
16 **Table A.2.1-1 PDE Simulator Response Types**

<b>MS Request</b>	<b>PDE Response</b>
<i>Request BS Capabilities</i>	<i>Provide BS Capabilities</i>
<i>Request GPS Acquisition Assistance</i>	<i>Provide GPS Acquisition Assistance</i>
<i>Request GPS Location Assistance</i> COORD_TYPE = '0'	<i>Provide GPS Location Assistance – Cartesian</i>
<i>Request GPS Location Assistance</i> COORD_TYPE = '1'	<i>Provide GPS Location Assistance – Spherical</i>
<i>Request GPS Sensitivity Assistance</i>	<i>Provide GPS Sensitivity Assistance</i>
<i>Request Base Station Almanac</i>	<i>Provide Base Station Almanac</i>
<i>Request GPS Almanac</i>	<i>Provide GPS Almanac</i>
<i>Request GPS Ephemeris</i>	<i>Provide GPS Ephemeris</i>
<i>Request GPS Navigation Message Bits</i>	<i>Provide GPS Navigation Message Bits</i>
<i>Request Location Response</i>	<i>Provide Location Response</i>
<i>Request GPS Almanac Correction</i>	<i>Provide GPS Almanac Correction</i>
<i>Request GPS Satellite Health Information</i>	<i>Provide GPS Satellite Health Information</i>

## 1 A.2.2 PDE Simulator Response Reference Time

2 When responding to a mobile station request, the PDE simulator shall determine the  
3 response reference time based on the time-of-arrival of the request and the stepsize for the  
4 response time. The stepsize for the response time here means the time step between  
5 consecutive response messages of the same type contained in Annex D. The number of  
6 possible PDE simulator response messages for a given message type is obtained by dividing  
7 the maximal supported test duration by the resolution of the reference time for that  
8 message type. For message types for which Table A.2.2-1 lists 'N/A' as resolution of  
9 reference time, there is only one possible PDE simulator response. The PDE simulator shall  
10 support maximal test duration of at least 60 minutes.

11

1

**Table A.2.2-1 PDE Simulator Response Reference Time Information**

<b>PDE Response</b>	<b>Reference Time Field</b>	<b>Stepsize for Response Time</b>	<b>Selection of Reference Time</b> <b>Note:</b> $t_{ref}$ = Reference Time, $t_{req}$ = Time-of-Arrival of <b>Mobile Station Request</b>
<i>Provide BS Capabilities</i>	N/A	N/A	N/A
<i>Provide GPS Acquisition Assistance</i>	TIME_OF_APP	1.28 s	$t_{req} + 2 \leq t_{ref} < t_{req} + 3.28$
<i>Provide GPS Location Assistance – Cartesian</i>	Implicit	1.28 s	Same as in <i>Provide GPS Acquisition Assistance</i> message
<i>Provide GPS Location Assistance – Spherical</i>	Implicit	1.28 s	Same as in <i>Provide GPS Acquisition Assistance</i> message
<i>Provide GPS Sensitivity Assistance</i>	REF_BIT_NUM	1.28 s	$t_{req} + 5 < t_{ref} \leq t_{req} + 6.28$
<i>Provide Base Station Almanac</i>	N/A	N/A	N/A
<i>Provide GPS Almanac</i>	WEEK_NUM	N/A	104
	TOA	N/A	16384
<i>Provide GPS Ephemeris</i>	IODE	N/A	Same as in reference Ephemeris
	TOE	N/A	324000
<i>Provide GPS Navigation Message Bits</i>	Implicit, start of next GPS frame	6 s	$t_{req} < t_{ref} \leq t_{req} + 6$
<i>Provide Location Response</i>	TIME_REF_CDMA	1.28 s	$t_{req} \leq t_{ref} < t_{req} + 1.28$
<i>Provide GPS Almanac Correction</i>	REF_TIME	10.24 s	$t_{req} + 2 \leq t_{ref} < t_{req} + 3.28$
	WEEK_NUM	N/A	Same as in reference Almanac
	TOA	N/A	Same as in reference Almanac

<i>Provide GPS Satellite Health Information</i>	N/A	N/A	N/A
---	-----	-----	-----

1

2 **A.3 Method of Determining the PDE Simulator Response Values**

## 3 A.3.1 Setting of PDE Simulator Response Field Counters

4 The PDE simulator shall set the field counters as listed in Table A.3.1-1.

5 The values of fields PART\_NUM and TOTAL\_PARTS, when applicable, shall be set by the  
6 PDE simulator according to A.1.3.

7

1

**Table A.3.1-1 PDE Simulator Response Field Counter Settings**

<b>PDE Response</b>	<b>Field Counter</b>	<b>Value (Binary)</b>	<b>Total Number in All Parts of the Response</b>
<i>Provide GPS Acquisition Assistance</i>	NUM_SV	Number of SVs above 18° elevation angle – 1 = '1000'	No segmentation
	DOPP_INCL	'1'	N/A
	ADD_DOPP_INCL	'1'	N/A
	CODE_PH_PAR_INCL	'1'	N/A
	AZ_EL_INCL	'1'	N/A
<i>Provide GPS Location Assistance – Cartesian</i>	NUM_DLY	'000'	No segmentation
	NUM_SV	Same as in <i>Provide GPS Acquisition Assistance</i> message	No segmentation
<i>Provide GPS Location Assistance – Spherical</i>	NUM_DLY	'000'	No segmentation
	NUM_SV	Same as in <i>Provide GPS Acquisition Assistance</i> message	No segmentation
<i>Provide GPS Sensitivity Assistance</i>	NUM_DR_P	As needed	Number of SVs above 18° elevation angle = 9
	DR_SIZE	'11111111'	N/A
	NUM_SV_DR	'0'	N/A
<i>Provide Base Station Almanac</i>	NUM_PILOTS_P	'000001001'	No segmentation
	LOC_SAME_AS_PREV	'0'	N/A
<i>Provide GPS Almanac</i>	NUM_SV_P	As needed	Number of SVs in reference Almanac = 26
<i>Provide GPS Ephemeris</i>	NUM_SV_P	As needed	Number of SVs above 18° elevation angle = 9
	AB_PAR_INCL	'1'	N/A
<i>Provide GPS Navigation Message Bits</i>	NUM_SV_P	As needed	Number of SVs above 18° elevation angle = 9
	SUBF_4_5_INCL	'0'	N/A
<i>Provide</i>	VELOCITY_INCL	'0'	N/A

<i>Location Response</i>	CLOCK_INCL	'0'	N/A
	HEIGHT_INCL	'1'	N/A
<i>Provide GPS Almanac Correction</i>	NUM_SV_P	Number of SVs above 18° elevation angle – 1 = '1000'	No segmentation
	DELTA_XYZ_INCL	'1'	N/A
	DELTA_CLOCK_INCL	'1'	N/A
<i>Provide GPS Satellite Health Information</i>	BAD_SV_PRESENT	'0'	N/A

1

## 2 A.3.2 Calculating of PDE Simulator Numerical Parameter Values

3 The PDE simulator response numerical data values shall be calculated according to the  
4 definitions of Section 2.5 of [21] and Section 4.2.4.2 of [1].

5 Furthermore, the following procedures shall apply:

- 6     ▪ Pseudorange, Doppler and Doppler rate of change values shall be calculated  
7     according to [16], based on the reference Ephemeris. Ionospheric and tropospheric  
8     corrections shall be applied as described in [16]. The serving base station's location  
9     shall be used as the reference location, and the time indicated by TIME\_OF\_APP shall  
10    be used as the reference time. Location coordinates shall be interpreted according to  
11    [17]. The rounding or truncation of the resulting values shall be carried out  
12    according to Section 4.2.4.2 of [1].
- 13    ▪ The Almanac, Ephemeris and GPS navigation bit data shall be set according to the  
14    GPS simulator data.

## 15 A.3.3 Setting of PDE Simulator Response Information Parameters

16 Unless otherwise indicated in specific tests, the PDE simulator shall set the response  
17 information parameters according to Table A.3.3-1.

18 The parameter values included in the *Provide Location Response* message were determined  
19 based on the assumption that the message may be sent as assistance to the mobile station  
20 before any measurements are made. The same *Provide Location Response* message shall be  
21 sent by the PDE simulator to the mobile station regardless of whether it is requested before  
22 or after any measurements are made; thus, it does not reflect the positioning accuracy that  
23 could be obtained from the measurements.

1

**Table A.3.3-1 PDE Simulator Response Information Parameters**

<b>PDE Response</b>	<b>Field</b>	<b>Value (Binary)</b>
<i>Provide BS Capabilities</i>	BS_LS_REV	'000000'
	GPSC_ID	'1'
	AFLTC_ID	'1'
	APDC_ID	'00000000'
<i>Reject</i>	REJ_REQ_TYPE	As needed, same as in MS request
	REJ_REASON	'001'
<i>Provide GPS Acquisition Assistance</i>	REFERENCE_PN	P <sub>0</sub>
	SV_CODE_PH_WIN	'01011'
	DOPPLER_WIN	'100'
<i>Provide Base Station Almanac</i>	TIME_CRRCTION_REF	'010111101'
	TIME_CORRECTION	'010111101'
<i>Provide Location Response</i>	FIX_TYPE	'1'

2

## 3 A.3.4 Setting of PDE Simulator Request Information Parameters

4 Unless otherwise indicated in specific tests, the PDE simulator shall set the request  
5 information parameters according to Table A.3.4-1.

6

**Table A.3.4-1 PDE Simulator Request Information Parameters**

<b>PDE Request</b>	<b>Field</b>	<b>Value (Binary)</b>
<i>Request Pseudorange Measurement</i>	PREF_RESP_QUAL	'100' for GPS Dynamic Range Test, '011' otherwise
	NUM_FIXES	'00000000'
	T_BETW_FIXES	'00010000'
	OFFSET_REQ	'1'
<i>Request Pilot Phase Measurement</i>	PREF_RESP_QUAL	'011' for AFLT Protocol Tests, '010' otherwise
	NUM_FIXES	'00000000'
	T_BETW_FIXES	'00010000'
	OFFSET_REQ	'1'
	DESI_PIL_PH_RES	'1'
<i>Request Location Response</i>	PREF_RESP_QUAL	'010' for AFLT Tests, '011' for GPS and Hybrid Tests
	NUM_FIXES	'00000000'
	T_BETW_FIXES	'00010000'
	HEIGHT_REQ	'1'
	CLK_COR_GPS_REQ	'1'
	VELOCITY_REQ	'1'

2

3



## 1 **Annex B – REFERENCE GPS NAVIGATION DATA, SYSTEM TIME AND USER LOCATION**

2 This Annex is normative.

### 3 **B.1 Reference Location**

4 For all tests defined in this document, the PDE simulator response messages shall be  
5 consistent with (i.e. all assistance data shall be valid at) the following reference location:

- 6     ▪ Lat: + 37° 00' 00.0000"
- 7     ▪ Lon: - 122° 00' 00.0000"
- 8     ▪ Height: + 100.00 m (above the WGS-84 Reference Ellipsoid)

### 9 **B.2 Reference Time**

10 For all tests defined in this document, the reference time (start time of the test) shall be as  
11 follows:

- 12     ▪ GPS Time: Week 1127 (WIN:0103), TOW: 320320 (Wednesday, 16:58:40)
- 13     ▪ Local Time (Pacific Standard Time): 2001 August 15, 08:58:40 am
- 14     ▪ Local Time (Pacific Daylight Time): 2001 August 15, 09:58:40 am

15 The test equipment shall support a test duration of 1 hour.

### 16 **B.3 Reference Ephemeris**

17 For all tests defined in this document, the following reference Ephemeris data shall be used.  
18 Note that the first number after the parameter name is the binary value of the  
19 corresponding message field defined in [1]; the second number (in parentheses) is the  
20 scaling factor expressed in powers of two; and the third number is the floating-point  
21 representation. For the applicable units, see [16]. Note that the IODE values shown below  
22 are not mandatory. Any IODE value can be used, as long as the PDE simulator response  
23 messages (see Annex D) are kept consistent with the settings of the GPS simulator.

```
24
25 alpha0 : 16 (2^-30)          1.49011611938477e-008
26 alpha1 : 3 (2^-27)          2.23517417907715e-008
27 alpha2 : -2 (2^-24)         -1.19209289550781e-007
28 alpha3 : -2 (2^-24)         -1.19209289550781e-007
29 beta0  : 55 (2^11)          112640
30 beta1  : 8 (2^14)           131072
31 beta2  : -2 (2^16)          -131072
32 beta3  : -3 (2^16)          -196608
```

```
33
34 *****SATELLITE: 3*****
```

```
35 ID      : 3
36 PRN ID  : 3
37 IODE    : 2
```

3GPP2 C.S0036-0 v1.0

```

1 Crs      : 1751 (2^-5)          54.71875
2 delta_n  : 13612 (2^-43)       1.54750523506664e-009
3 M_0      : 1554268988 (2^-31)  0.723762897774577
4 Cuc      : 1505 (2^-29)        2.80328094959259e-006
5 e        : 18979682 (2^-33)    0.00220952578820288
6 Cus      : 5898 (2^-29)        1.09858810901642e-005
7 SQRT(A)  : 2702017974 (2^-19)  5153.6902885437
8 toe      : 20250 (2^4)         324000
9 Cic      : -27 (2^-29)         -5.02914190292358e-008
10 OMEGA_0  : -598861499 (2^-31) -0.278866616543382
11 Cis      : -27 (2^-29)         -5.02914190292358e-008
12 i0       : 639774141 (2^-31)  0.297918050084263
13 Crc      : 4897 (2^-5)         153.03125
14 omega    : 392157920 (2^-31)  0.182612761855125
15 OMEGADOT: -22673 (2^-43)       -2.5776216716622e-009
16 IDOT     : -1344 (2^-43)       -1.52795109897852e-010
17 toc      : 20250 (2^4)         324000
18 af2      : 0 (2^-55)           0
19 af1      : 30 (2^-43)          3.41060513164848e-012
20 af0      : 122521 (2^-31)      5.70532865822315e-005

```

21

\*\*\*\*\*SATELLITE: 14\*\*\*\*\*

```

22 ID       : 14
23 PRN ID   : 14
24 IODE     : 2
25 Crs      : -4016 (2^-5)         -125.5
26 delta_n  : 11923 (2^-43)       1.35548816615483e-009
27 M_0      : 627487520 (2^-31)  0.292196646332741
28 Cuc      : -3440 (2^-29)       -6.40749931335449e-006
29 e        : 20828844 (2^-33)    0.00242479657754302
30 Cus      : 5468 (2^-29)        1.01849436759949e-005
31 SQRT(A)  : 2702005606 (2^-19)  5153.66669845581
32 toe      : 20250 (2^4)         324000
33 Cic      : 19 (2^-29)          3.53902578353882e-008
34 OMEGA_0  : 1577408628 (2^-31)  0.734538132324815
35 Cis      : 0 (2^-29)           0
36 i0       : 659197995 (2^-31)  0.306962986942381
37 Crc      : 5906 (2^-5)         184.5625
38 omega    : -318920472 (2^-31) -0.148508917540312
39 OMEGADOT: -22013 (2^-43)       -2.50258835876593e-009
40 IDOT     : 241 (2^-43)         2.73985278909095e-011
41 toc      : 20250 (2^4)         324000
42 af2      : 0 (2^-55)           0
43 af1      : -9 (2^-43)          -1.02318153949454e-012
44 af0      : -259636 (2^-31)     -0.000120902433991432

```

46

```

1 *****SATELLITE: 15*****
2 ID      : 15
3 PRN ID  : 15
4 IODE    : 2
5 Crs     : 3520 (2^-5)          110
6 delta_n : 11425 (2^-43)       1.29887212096946e-009
7 M_0     : 783064363 (2^-31)   0.364642759319395
8 Cuc     : 2968 (2^-29)         5.52833080291748e-006
9 e       : 70170715 (2^-33)    0.00816894636955112
10 Cus    : 2420 (2^-29)         4.50760126113892e-006
11 SQRT(A) : 2702005530 (2^-19)  5153.66655349731
12 toe    : 20250 (2^4)          324000
13 Cic    : -28 (2^-29)          -5.21540641784668e-008
14 OMEGA_0 : 196273480 (2^-31)   0.0913969613611698
15 Cis    : -111 (2^-29)         -2.06753611564636e-007
16 i0     : 669824293 (2^-31)   0.311911242548376
17 Crs    : 9659 (2^-5)          301.84375
18 omega  : 1184210256 (2^-31)   0.551440872251987
19 OMEGADOT: -22831 (2^-43)      -2.59558419202222e-009
20 IDOT   : 754 (2^-43)          8.57198756420985e-011
21 toc    : 20250 (2^4)          324000
22 af2    : 0 (2^-55)            0
23 af1    : 40 (2^-43)           4.54747350886464e-012
24 af0    : 150252 (2^-31)       6.99665397405624e-005

```

```

25
26 *****SATELLITE: 17*****
27 ID      : 17
28 PRN ID  : 17
29 IODE    : 2
30 Crs     : 3234 (2^-5)          101.0625
31 delta_n : 11586 (2^-43)       1.31717570184264e-009
32 M_0     : 21453549 (2^-31)    0.00999008724465966
33 Cuc     : 2836 (2^-29)         5.28246164321899e-006
34 e       : 114688506 (2^-33)   0.0133514993358403
35 Cus    : 2103 (2^-29)         3.9171427488327e-006
36 SQRT(A) : 2702016898 (2^-19)  5153.68823623657
37 toe    : 20250 (2^4)          324000
38 Cic    : 99 (2^-29)           1.84401869773865e-007
39 OMEGA_0 : 223657985 (2^-31)   0.104148865211755
40 Cis    : -24 (2^-29)          -4.4703483581543e-008
41 i0     : 671066978 (2^-31)   0.312489912845194
42 Crs    : 10023 (2^-5)         313.21875
43 omega  : 2143332909 (2^-31)   0.998067161533982
44 OMEGADOT: -23226 (2^-43)      -2.64049049292225e-009
45 IDOT   : 765 (2^-43)          8.69704308570363e-011
46 toc    : 20250 (2^4)          324000

```

3GPP2 C.S0036-0 v1.0

```

1  af2      : 0 (2^-55)           0
2  af1      : 226 (2^-43)        2.56932253250852e-011
3  af0      : 771310 (2^-31)     0.000359169207513332
4
5  *****SATELLITE: 18*****
6  ID       : 18
7  PRN ID   : 18
8  IODE     : 2
9  Crs      : -2414 (2^-5)       -75.4375
10 delta_n  : 13174 (2^-43)      1.49771040014457e-009
11 M_0      : -412701330 (2^-31) -0.192179032601416
12 Cuc      : -2089 (2^-29)      -3.89106571674347e-006
13 e        : 18954306 (2^-33)   0.0022065716329962
14 Cus      : 1071 (2^-29)       1.99489295482636e-006
15 SQR(A)   : 2701992381 (2^-19) 5153.64147377014
16 toe      : 20250 (2^4)        324000
17 Cic      : -12 (2^-29)        -2.23517417907715e-008
18 OMEGA_0  : 898577843 (2^-31)  0.418432915117592
19 Cis      : 2 (2^-29)          3.72529029846191e-009
20 i0       : 656996200 (2^-31)  0.305937696248293
21 Crs      : 10900 (2^-5)       340.625
22 omega    : 1845863650 (2^-31) 0.859547243453562
23 OMEGADOT: -23748 (2^-43)      -2.69983502221294e-009
24 IDOT     : -213 (2^-43)       -2.42152964347042e-011
25 toc      : 20250 (2^4)        324000
26 af2      : 0 (2^-55)           0
27 af1      : -2 (2^-43)         -2.27373675443232e-013
28 af0      : -158560 (2^-31)    -7.38352537155151e-005
29
30 *****SATELLITE: 21*****
31 ID       : 21
32 PRN ID   : 21
33 IODE     : 2
34 Crs      : -2326 (2^-5)       -72.6875
35 delta_n  : 12066 (2^-43)      1.37174538394902e-009
36 M_0      : -1590806617 (2^-31) -0.74077705712989
37 Cuc      : -2100 (2^-29)      -3.91155481338501e-006
38 e        : 149802739 (2^-33)  0.0174393340712413
39 Cus      : 819 (2^-29)        1.52550637722015e-006
40 SQR(A)   : 2701986661 (2^-19) 5153.63056373596
41 toe      : 20250 (2^4)        324000
42 Cic      : 94 (2^-29)         1.7508864402771e-007
43 OMEGA_0  : 869520218 (2^-31)  0.404901904053986
44 Cis      : -79 (2^-29)        -1.47148966789246e-007
45 i0       : 668563068 (2^-31)  0.311323938891292
46 Crs      : 11468 (2^-5)       358.375

```

```

1  omega   : -1656971549 (2^-31)   -0.771587504539639
2  OMEGADOT: -22726 (2^-43)        -2.58364707406145e-009
3  IDOT    : 246 (2^-43)           2.79669620795175e-011
4  toc     : 20250 (2^4)           324000
5  af2     : 0 (2^-55)             0
6  af1     : 1 (2^-43)            1.13686837721616e-013
7  af0     : 9981 (2^-31)         4.64776530861855e-006
8
9  *****SATELLITE: 23*****
10 ID      : 23
11 PRN ID  : 23
12 IODE    : 2
13 Crs     : -2351 (2^-5)          -73.46875
14 delta_n : 11761 (2^-43)        1.33707089844393e-009
15 M_0     : -1378456920 (2^-31)  -0.641894023865461
16 Cuc     : -1911 (2^-29)        -3.55951488018036e-006
17 e       : 132793870 (2^-33)    0.0154592411126941
18 Cus     : 923 (2^-29)          1.71922147274017e-006
19 SQRT(A) : 2701831446 (2^-19)   5153.33451461792
20 toe     : 20250 (2^4)           324000
21 Cic     : 100 (2^-29)          1.86264514923096e-007
22 OMEGA_0 : 898428473 (2^-31)    0.418363359291106
23 Cis     : 42 (2^-29)           7.82310962677002e-008
24 i0      : 670774976 (2^-31)    0.312353938817978
25 Crs     : 11248 (2^-5)         351.5
26 omega   : -1245550721 (2^-31)  -0.580004752147943
27 OMEGADOT: -22412 (2^-43)        -2.54794940701686e-009
28 IDOT    : 22 (2^-43)           2.50111042987555e-012
29 toc     : 20250 (2^4)           324000
30 af2     : 0 (2^-55)             0
31 af1     : 6 (2^-43)            6.82121026329696e-013
32 af0     : 39215 (2^-31)        1.8260907381773e-005
33
34 *****SATELLITE: 29*****
35 ID      : 29
36 PRN ID  : 29
37 IODE    : 2
38 Crs     : -4216 (2^-5)          -131.75
39 delta_n : 11731 (2^-43)        1.33366029331228e-009
40 M_0     : 1396677043 (2^-31)   0.650378429796547
41 Cuc     : -3652 (2^-29)        -6.80238008499146e-006
42 e       : 71698904 (2^-33)    0.0083468509837985
43 Cus     : 5364 (2^-29)          9.99122858047485e-006
44 SQRT(A) : 2702123387 (2^-19)   5153.89134788513
45 toe     : 20250 (2^4)           324000
46 Cic     : 9 (2^-29)            1.67638063430786e-008

```

```

1  OMEGA_0 : 1563399006 (2^-31)    0.7280143937096
2  Cis     : -103 (2^-29)          -1.91852450370789e-007
3  i0      : 659786730 (2^-31)    0.307237138040364
4  Crc     : 6053 (2^-5)           189.15625
5  omega   : -1269281011 (2^-31)  -0.591055029537529
6  OMEGADOT: -21749 (2^-43)        -2.47257503360743e-009
7  IDOT    : 259 (2^-43)           2.94448909698986e-011
8  toc     : 20250 (2^4)           324000
9  af2     : 0 (2^-55)             0
10 af1     : 17 (2^-43)             1.93267624126747e-012
11 af0     : 1346363 (2^-31)       0.00062694912776351
12
13 *****SATELLITE: 31*****
14 ID      : 31
15 PRN ID  : 31
16 IODE    : 2
17 Crs     : 1383 (2^-5)            43.21875
18 delta_n : 13054 (2^-43)          1.48406797961798e-009
19 M_0     : 971966542 (2^-31)     0.452607191167772
20 Cuc     : 1228 (2^-29)           2.28732824325562e-006
21 e       : 87696983 (2^-33)      0.0102092724991962
22 Cus     : 6029 (2^-29)           1.12298876047134e-005
23 SQRT(A) : 2702009354 (2^-19)    5153.67384719849
24 toe     : 20250 (2^4)            324000
25 Cic     : -100 (2^-29)           -1.86264514923096e-007
26 OMEGA_0 : -588296382 (2^-31)    -0.273946850560606
27 Cis     : 7 (2^-29)              1.30385160446167e-008
28 i0      : 645775312 (2^-31)     0.300712563097477
29 Crc     : 5024 (2^-5)            157
30 omega   : 592891816 (2^-31)     0.276086766272783
31 OMEGADOT: -22745 (2^-43)         -2.58580712397816e-009
32 IDOT    : -1607 (2^-43)          -1.82694748218637e-010
33 toc     : 20250 (2^4)            324000
34 af2     : 0 (2^-55)             0
35 af1     : 17 (2^-43)             1.93267624126747e-012
36 af0     : 125895 (2^-31)        5.86244277656078e-005

```

37

#### 38 **B.4 Reference Almanac**

39 For all tests defined in this document, the following reference Almanac data shall be used.  
40 Note that the first number after the parameter name is the binary value of the  
41 corresponding message field defined in [1]; the second number (in parentheses) is the  
42 scaling factor expressed in powers of two; and the third number is the floating-point  
43 representation. For the applicable units, see [16].

44

```

1 WIN=104
2 toa : 4 (2^12)          16384
3
4 *****SATELLITE: 1*****
5 PRN ID   : 1
6 delta_i  : 3839 (2^-19)    0.00732231140136719
7 M_0      : -709057 (2^-23) -0.0845261812210083
8 e        : 10598 (2^-21)   0.00505352020263672
9 SQR(A)   : 10554807 (2^-11) 5153.71435546875
10 OMEGA_0  : 5901355 (2^-23)  0.703496336936951
11 omega    : -4575499 (2^-23) -0.54544198513031
12 OMEGADOT: -687 (2^-38)     -2.49929144047201e-009
13 af1      : 1 (2^-38)       3.63797880709171e-012
14 af0      : 201 (2^-20)     0.000191688537597656
15
16 *****SATELLITE: 2*****
17 PRN ID   : 2
18 delta_i  : -1649 (2^-19)   -0.00314521789550781
19 M_0      : 8006721 (2^-23)  0.954475522041321
20 e        : 44805 (2^-21)   0.021364688873291
21 SQR(A)   : 10554554 (2^-11) 5153.5908203125
22 OMEGA_0  : -5549822 (2^-23) -0.661590337753296
23 omega    : -5393208 (2^-23) -0.64292049407959
24 OMEGADOT: -723 (2^-38)     -2.63025867752731e-009
25 af1      : -2 (2^-38)      -7.27595761418343e-012
26 af0      : -65 (2^-20)     -6.19888305664063e-005
27
28 *****SATELLITE: 3*****
29 PRN ID   : 3
30 delta_i  : -1115 (2^-19)   -0.00212669372558594
31 M_0      : 4373628 (2^-23)  0.521377086639404
32 e        : 4634 (2^-21)    0.00220966339111328
33 SQR(A)   : 10554758 (2^-11) 5153.6904296875
34 OMEGA_0  : -2667259 (2^-23) -0.317962050437927
35 omega    : 1531867 (2^-23)  0.182612776756287
36 OMEGADOT: -709 (2^-38)     -2.57932697422802e-009
37 af1      : 1 (2^-38)       3.63797880709171e-012
38 af0      : 61 (2^-20)      5.81741333007813e-005
39
40 *****SATELLITE: 4*****
41 PRN ID   : 4
42 delta_i  : 5180 (2^-19)    0.00988006591796875
43 M_0      : -2766861 (2^-23) -0.329835534095764
44 e        : 11382 (2^-21)   0.00542736053466797
45 SQR(A)   : 10554840 (2^-11) 5153.73046875
46 OMEGA_0  : 317784 (2^-23)  0.0378828048706055

```

3GPP2 C.S0036-0 v1.0

```

1  omega   : -1101514 (2^-23)   -0.131310701370239
2  OMEGADOT: -678 (2^-38)      -2.46654963120818e-009
3  af1     : -5 (2^-38)        -1.81898940354586e-011
4  af0     : 629 (2^-20)       0.000599861145019531
5
6  *****SATELLITE: 5*****
7  PRN ID  : 5
8  delta_i : -1140 (2^-19)     -0.00217437744140625
9  M_0     : -3255290 (2^-23)  -0.388060808181763
10 e       : 6206 (2^-21)      0.00295925140380859
11 SQRT(A) : 10554460 (2^-11)  5153.544921875
12 OMEGA_0 : -5494160 (2^-23)  -0.65495491027832
13 omega   : 1091980 (2^-23)   0.130174160003662
14 OMEGADOT: -724 (2^-38)     -2.6338966563344e-009
15 af1     : 0 (2^-38)         0
16 af0     : 325 (2^-20)       0.000309944152832031
17
18 *****SATELLITE: 6*****
19 PRN ID  : 6
20 delta_i : 165 (2^-19)       0.000314712524414063
21 M_0     : -416309 (2^-23)   -0.0496279001235962
22 e       : 14416 (2^-21)     0.00687408447265625
23 SQRT(A) : 10554647 (2^-11)  5153.63623046875
24 OMEGA_0 : -2545582 (2^-23)  -0.303457021713257
25 omega   : -6075586 (2^-23)  -0.724266290664673
26 OMEGADOT: -692 (2^-38)     -2.51748133450747e-009
27 af1     : 0 (2^-38)         0
28 af0     : -3 (2^-20)       -2.86102294921875e-006
29
30 *****SATELLITE: 7*****
31 PRN ID  : 7
32 delta_i : 454 (2^-19)       0.000865936279296875
33 M_0     : 4956962 (2^-23)   0.59091591835022
34 e       : 25192 (2^-21)     0.0120124816894531
35 SQRT(A) : 10554774 (2^-11)  5153.6982421875
36 OMEGA_0 : -2625876 (2^-23)  -0.313028812408447
37 omega   : -5357772 (2^-23)  -0.638696193695068
38 OMEGADOT: -694 (2^-38)     -2.52475729212165e-009
39 af1     : -9 (2^-38)       -3.27418092638254e-011
40 af0     : 416 (2^-20)      0.000396728515625
41
42 *****SATELLITE: 8*****
43 PRN ID  : 8
44 delta_i : 2813 (2^-19)      0.00536537170410156
45 M_0     : 382759 (2^-23)   0.0456284284591675
46 e       : 16794 (2^-21)    0.00800800323486328

```

```

1  SQRT(A) : 10554740 (2^-11)      5153.681640625
2  OMEGA_0 : -8055571 (2^-23)     -0.960298895835876
3  omega   : 5432166 (2^-23)      0.647564649581909
4  OMEGADOT: -672 (2^-38)         -2.44472175836563e-009
5  af1     : 7 (2^-38)            2.5465851649642e-011
6  af0     : 513 (2^-20)          0.000489234924316406
7
8  *****SATELLITE: 9*****
9  PRN ID  : 9
10 delta_i : 505 (2^-19)           0.000963211059570313
11 M_0     : -1092959 (2^-23)     -0.130290865898132
12 e       : 25411 (2^-21)        0.0121169090270996
13 SQRT(A) : 10554686 (2^-11)     5153.6552734375
14 OMEGA_0 : -8197457 (2^-23)     -0.977213025093079
15 omega   : 1966584 (2^-23)      0.234435081481934
16 OMEGADOT: -685 (2^-38)         -2.49201548285782e-009
17 af1     : -1 (2^-38)           -3.63797880709171e-012
18 af0     : -4 (2^-20)           -3.814697265625e-006
19
20 *****SATELLITE: 10*****
21 PRN ID  : 10
22 delta_i : 6000 (2^-19)          0.011444091796875
23 M_0     : 8097346 (2^-23)      0.96527886390686
24 e       : 9435 (2^-21)         0.00449895858764648
25 SQRT(A) : 10554528 (2^-11)     5153.578125
26 OMEGA_0 : 3052626 (2^-23)      0.363901376724243
27 omega   : 238987 (2^-23)       0.0284894704818726
28 OMEGADOT: -717 (2^-38)         -2.60843080468476e-009
29 af1     : 0 (2^-38)            0
30 af0     : 9 (2^-20)            8.58306884765625e-006
31
32 *****SATELLITE: 11*****
33 PRN ID  : 11
34 delta_i : -3527 (2^-19)         -0.00672721862792969
35 M_0     : 7618680 (2^-23)      0.908217430114746
36 e       : 2164 (2^-21)         0.00103187561035156
37 SQRT(A) : 10554691 (2^-11)     5153.65771484375
38 OMEGA_0 : 115484 (2^-23)       0.0137667655944824
39 omega   : -6792224 (2^-23)     -0.809696197509766
40 OMEGADOT: -719 (2^-38)         -2.61570676229894e-009
41 af1     : 0 (2^-38)            0
42 af0     : 4 (2^-20)            3.814697265625e-006
43
44 *****SATELLITE: 13*****
45 PRN ID  : 13
46 delta_i : 4536 (2^-19)          0.0086517333984375

```

3GPP2 C.S0036-0 v1.0

1 M\_0 : -6993686 (2<sup>-23</sup>) -0.833712339401245  
 2 e : 4071 (2<sup>-21</sup>) 0.00194120407104492  
 3 SQRT(A) : 10554723 (2<sup>-11</sup>) 5153.67333984375  
 4 OMEGA\_0 : 5844615 (2<sup>-23</sup>) 0.696732401847839  
 5 omega : 168349 (2<sup>-23</sup>) 0.0200687646865845  
 6 OMEGADOT: -685 (2<sup>-38</sup>) -2.49201548285782e-009  
 7 af1 : 0 (2<sup>-38</sup>) 0  
 8 af0 : -4 (2<sup>-20</sup>) -3.814697265625e-006

9

10 \*\*\*\*\*SATELLITE: 14\*\*\*\*\*

11 PRN ID : 14  
 12 delta\_i : 3655 (2<sup>-19</sup>) 0.00697135925292969  
 13 M\_0 : 754499 (2<sup>-23</sup>) 0.0899432897567749  
 14 e : 5085 (2<sup>-21</sup>) 0.00242471694946289  
 15 SQRT(A) : 10554709 (2<sup>-11</sup>) 5153.66650390625  
 16 OMEGA\_0 : 5833984 (2<sup>-23</sup>) 0.695465087890625  
 17 omega : -1245783 (2<sup>-23</sup>) -0.148508906364441  
 18 OMEGADOT: -688 (2<sup>-38</sup>) -2.5029294192791e-009  
 19 af1 : 0 (2<sup>-38</sup>) 0  
 20 af0 : -127 (2<sup>-20</sup>) -0.000121116638183594

21

22 \*\*\*\*\*SATELLITE: 15\*\*\*\*\*

23 PRN ID : 15  
 24 delta\_i : 6258 (2<sup>-19</sup>) 0.0119361877441406  
 25 M\_0 : 1362090 (2<sup>-23</sup>) 0.162373781204224  
 26 e : 17132 (2<sup>-21</sup>) 0.00816917419433594  
 27 SQRT(A) : 10554709 (2<sup>-11</sup>) 5153.66650390625  
 28 OMEGA\_0 : 438693 (2<sup>-23</sup>) 0.0522962808609009  
 29 omega : 4625821 (2<sup>-23</sup>) 0.551440834999084  
 30 OMEGADOT: -713 (2<sup>-38</sup>) -2.59387888945639e-009  
 31 af1 : 1 (2<sup>-38</sup>) 3.63797880709171e-012  
 32 af0 : 75 (2<sup>-20</sup>) 7.15255737304688e-005

33

34 \*\*\*\*\*SATELLITE: 17\*\*\*\*\*

35 PRN ID : 17  
 36 delta\_i : 6562 (2<sup>-19</sup>) 0.0125160217285156  
 37 M\_0 : -1614368 (2<sup>-23</sup>) -0.192447662353516  
 38 e : 28000 (2<sup>-21</sup>) 0.0133514404296875  
 39 SQRT(A) : 10554754 (2<sup>-11</sup>) 5153.6884765625  
 40 OMEGA\_0 : 545551 (2<sup>-23</sup>) 0.0650347471237183  
 41 omega : 8372394 (2<sup>-23</sup>) 0.998067140579224  
 42 OMEGADOT: -726 (2<sup>-38</sup>) -2.64117261394858e-009  
 43 af1 : 7 (2<sup>-38</sup>) 2.5465851649642e-011  
 44 af0 : 385 (2<sup>-20</sup>) 0.000367164611816406

45

46 \*\*\*\*\*SATELLITE: 18\*\*\*\*\*

```

1 PRN ID : 18
2 delta_i : 3109 (2^-19)          0.00592994689941406
3 M_0     : -3306685 (2^-23)     -0.394187569618225
4 e       : 4628 (2^-21)         0.00220680236816406
5 SQRT(A) : 10554658 (2^-11)     5153.6416015625
6 OMEGA_0 : 3181809 (2^-23)     0.379301190376282
7 omega   : 7210405 (2^-23)     0.859547257423401
8 OMEGADOT: -742 (2^-38)        -2.69938027486205e-009
9 af1     : 0 (2^-38)            0
10 af0    : -77 (2^-20)          -7.34329223632813e-005
11
12 *****SATELLITE: 20*****
13 PRN ID : 20
14 delta_i : 3240 (2^-19)          0.0061798095703125
15 M_0     : -7906351 (2^-23)     -0.942510485649109
16 e       : 4718 (2^-21)         0.00224971771240234
17 SQRT(A) : 10554829 (2^-11)     5153.72509765625
18 OMEGA_0 : 3042589 (2^-23)     0.362704873085022
19 omega   : 5562936 (2^-23)     0.663153648376465
20 OMEGADOT: -730 (2^-38)        -2.65572452917695e-009
21 af1     : -1 (2^-38)           -3.63797880709171e-012
22 af0    : -97 (2^-20)          -9.25064086914063e-005
23
24 *****SATELLITE: 21*****
25 PRN ID : 21
26 delta_i : 5941 (2^-19)          0.0113315582275391
27 M_0     : -7908237 (2^-23)     -0.942735314369202
28 e       : 36573 (2^-21)        0.0174393653869629
29 SQRT(A) : 10554635 (2^-11)     5153.63037109375
30 OMEGA_0 : 3068592 (2^-23)     0.365804672241211
31 omega   : -6472545 (2^-23)    -0.771587491035461
32 OMEGADOT: -710 (2^-38)        -2.58296495303512e-009
33 af1     : 0 (2^-38)            0
34 af0    : 5 (2^-20)             4.76837158203125e-006
35
36 *****SATELLITE: 23*****
37 PRN ID : 23
38 delta_i : 6477 (2^-19)          0.0123538970947266
39 M_0     : -7058884 (2^-23)     -0.841484546661377
40 e       : 32420 (2^-21)        0.0154590606689453
41 SQRT(A) : 10554029 (2^-11)     5153.33447265625
42 OMEGA_0 : 3181604 (2^-23)     0.379276752471924
43 omega   : -4865433 (2^-23)    -0.580004811286926
44 OMEGADOT: -700 (2^-38)        -2.5465851649642e-009
45 af1     : 0 (2^-38)            0
46 af0    : 19 (2^-20)           1.81198120117188e-005

```

3GPP2 C.S0036-0 v1.0

```

1
2 *****SATELLITE: 24*****
3 PRN ID   : 24
4 delta_i  : 6865 (2^-19)          0.0130939483642578
5 M_0      : -1059000 (2^-23)     -0.126242637634277
6 e        : 19382 (2^-21)         0.00924205780029297
7 SQR(A)   : 10554441 (2^-11)     5153.53564453125
8 OMEGA_0  : 361690 (2^-23)        0.0431168079376221
9 omega    : -4354610 (2^-23)     -0.519109964370728
10 OMEGADOT: -671 (2^-38)          -2.44108377955854e-009
11 af1      : 1 (2^-38)            3.63797880709171e-012
12 af0      : 78 (2^-20)           7.43865966796875e-005
13
14 *****SATELLITE: 25*****
15 PRN ID   : 25
16 delta_i  : -695 (2^-19)          -0.00132560729980469
17 M_0      : 1146872 (2^-23)       0.136717796325684
18 e        : 18977 (2^-21)         0.0090489387512207
19 SQR(A)   : 10554791 (2^-11)     5153.70654296875
20 OMEGA_0  : -8310991 (2^-23)     -0.990747332572937
21 omega    : -5198429 (2^-23)     -0.619701027870178
22 OMEGADOT: -691 (2^-38)          -2.51384335570037e-009
23 af1      : 0 (2^-38)            0
24 af0      : 17 (2^-20)           1.62124633789063e-005
25
26 *****SATELLITE: 27*****
27 PRN ID   : 27
28 delta_i  : 57 (2^-19)            0.000108718872070313
29 M_0      : -2921613 (2^-23)     -0.348283410072327
30 e        : 31945 (2^-21)         0.0152325630187988
31 SQR(A)   : 10554622 (2^-11)     5153.6240234375
32 OMEGA_0  : -8248422 (2^-23)     -0.983288526535034
33 omega    : -6816704 (2^-23)     -0.812614440917969
34 OMEGADOT: -684 (2^-38)          -2.48837750405073e-009
35 af1      : 0 (2^-38)            0
36 af0      : 32 (2^-20)           3.0517578125e-005
37
38 *****SATELLITE: 28*****
39 PRN ID   : 28
40 delta_i  : 2801 (2^-19)           0.00534248352050781
41 M_0      : -6238231 (2^-23)     -0.74365508556366
42 e        : 11107 (2^-21)         0.00529623031616211
43 SQR(A)   : 10557146 (2^-11)     5154.8564453125
44 OMEGA_0  : -5340170 (2^-23)     -0.636597871780396
45 omega    : -6362118 (2^-23)     -0.758423566818237
46 OMEGADOT: -700 (2^-38)          -2.5465851649642e-009

```

```

1  af1      : -1 (2^-38)          -3.63797880709171e-012
2  af0      : -14 (2^-20)         -1.33514404296875e-005
3
4  *****SATELLITE: 29*****
5  PRN ID   : 29
6  delta_i  : 3799 (2^-19)         0.00724601745605469
7  M_0      : 3743957 (2^-23)      0.446314454078674
8  e         : 17505 (2^-21)        0.0083470344543457
9  SQRT(A)  : 10555169 (2^-11)     5153.89111328125
10 OMEGA_0  : 5779333 (2^-23)       0.688950181007385
11 omega     : -4958129 (2^-23)     -0.591055035591125
12 OMEGADOT : -680 (2^-38)         -2.47382558882236e-009
13 af1      : 1 (2^-38)            3.63797880709171e-012
14 af0      : 658 (2^-20)          0.000627517700195313
15
16 *****SATELLITE: 30*****
17 PRN ID   : 30
18 delta_i  : 47 (2^-19)           8.96453857421875e-005
19 M_0      : -7232067 (2^-23)     -0.86212956905365
20 e         : 11969 (2^-21)        0.0057072639465332
21 SQRT(A)  : 10554571 (2^-11)     5153.59912109375
22 OMEGA_0  : -5402649 (2^-23)     -0.644045948982239
23 omega     : 3629757 (2^-23)      0.432700753211975
24 OMEGADOT : -718 (2^-38)         -2.61206878349185e-009
25 af1      : 0 (2^-38)            0
26 af0      : -33 (2^-20)          -3.14712524414063e-005
27
28 *****SATELLITE: 31*****
29 PRN ID   : 31
30 delta_i  : 345 (2^-19)           0.000658035278320313
31 M_0      : 2099959 (2^-23)       0.250334620475769
32 e         : 21410 (2^-21)        0.0102090835571289
33 SQRT(A)  : 10554724 (2^-11)     5153.673828125
34 OMEGA_0  : -2626009 (2^-23)     -0.313044667243958
35 omega     : 2315984 (2^-23)      0.276086807250977
36 OMEGADOT : -711 (2^-38)         -2.58660293184221e-009
37 af1      : 1 (2^-38)            3.63797880709171e-012
38 af0      : 62 (2^-20)           5.91278076171875e-005

```

39

#### 40 **B.5 List of Active Satellites**

41 Assistance shall be provided in all tests for the satellites having the following PRN numbers:

42 3, 14, 15, 17, 18, 21, 23, 29, 31

43 Satellites identified with the following PRN numbers shall be simulated in the tests:

1 1. GPS Accuracy, GPS Dynamic Range, GPS Moving Scenario and GPS Protocol Tests:

2 3, 14, 15, 17, 18, 21, 29, 31

3 2. GPS Sensitivity Test:

4 14, 17, 21, 31

5 3. GPS Multipath Accuracy Test:

6 14, 17, 18, 21, 31

7 4. One Base Station + Three Satellites Hybrid Test:

8 14, 17, 31

9 5. Two Base Stations + One Satellite Hybrid Test:

10 3

11 **B.6 Simulated Base Station Locations**

12 For all tests defined in this document, the simulated base station locations shall be as  
13 follows:

14 1. Base Station 1:

15 ▪ Lat: + 37° 00' 00.0000"

16 ▪ Lon: - 122° 00' 00.0000"

17 ▪ Height: + 150.00 m (above the WGS-84 Reference Ellipsoid)

18 2. Base Station 2:

19 ▪ Lat: + 36° 57' 39.5249"

20 ▪ Lon: - 121° 58' 18.9429"

21 ▪ Height: + 150.00 m (above the WGS-84 Reference Ellipsoid)

22 3. Base Station 3:

23 ▪ Lat: + 36° 57' 39.5249"

24 ▪ Lon: - 122° 01' 41.0571"

25 ▪ Height: + 150.00 m (above the WGS-84 Reference Ellipsoid)

26 **B.7 Simulated Mobile Station Locations**

27 The simulated mobile station locations shall be as follows:

28 1. GPS Accuracy, GPS Sensitivity, GPS Dynamic Range and GPS Multipath Tests:

29 ▪ Lat: + 36° 58' 26.3580"

30 ▪ Lon: - 122° 00' 00.0000"

31 ▪ Height: + 115.00 m (above the WGS-84 Reference Ellipsoid)

32 2. GPS Moving Scenario Test:

1           The mobile station's trajectory is a circle in the horizontal plane, with a radius of  
2           1 km, centered at the following location:

- 3       ▪ Lat: + 37° 00' 00.0000"
- 4       ▪ Lon: - 122° 00' 00.0000"
- 5       ▪ Height: + 115.00 m (above the WGS-84 Reference Ellipsoid)

6           The mobile station's initial position at reference time (see B.2) shall be set as  
7           follows:

- 8       ▪ Lat: + 36° 59' 27.5618"
- 9       ▪ Lon: - 122° 00' 00.0000"
- 10      ▪ Height: + 115.00 m (above the WGS-84 Reference Ellipsoid)

11           The mobile station's velocity is constant at 100 km/h, with an initial heading of -  
12           90° at reference time (see B.2).

13   3. GPS Protocol, all AFLT and Hybrid Tests:

- 14      ▪ Lat: + 36° 58' 26.3580"
- 15      ▪ Lon: - 122° 00' 00.0000"
- 16      ▪ Height: + 115.00 m (above the WGS-84 Reference Ellipsoid)

### 17   **B.8 Additional GPS Simulator Settings**

18   The settings shown in Table B.8-1 are also applied in the GPS simulator set-up. Note that  
19   the IODE and IODC values shown in Table B.8-1 are not mandatory. Any IODE or IODC  
20   value can be used, as long as the PDE simulator response messages (see Annex D) are kept  
21   consistent with the settings of the GPS simulator.

22

1

**Table B.8-1 GPS Simulator Settings**

SV	IODC	IODE	URA	$T_{GD}$ (ns)	A/S Flag	Alert Flag	SV Health in Frame 25	SV Health in Valid Almanac Pages	SV Conf.
1	-	-	-	-	-	-	'000000'	'00000000'	'0001'
2	-	-	-	-	-	-	'000000'	'00000000'	'0001'
3	2	2	0	-4.656612873	'0'	'0'	'000000'	'00000000'	'0001'
4	-	-	-	-	-	-	'000000'	'00000000'	'0001'
5	-	-	-	-	-	-	'000000'	'00000000'	'0001'
6	-	-	-	-	-	-	'000000'	'00000000'	'0001'
7	-	-	-	-	-	-	'000000'	'00000000'	'0001'
8	-	-	-	-	-	-	'000000'	'00000000'	'0001'
9	-	-	-	-	-	-	'000000'	'00000000'	'0001'
10	-	-	-	-	-	-	'000000'	'00000000'	'0001'
11	-	-	-	-	-	-	'000000'	'00000000'	'0001'
12	-	-	-	-	-	-	'111111'	-	'0001'
13	-	-	-	-	-	-	'000000'	'00000000'	'0001'
14	2	2	2	-10.24454832	'0'	'0'	'000000'	'00000000'	'0001'
15	2	2	1	-2.793967724	'0'	'0'	'000000'	'00000000'	'0001'
16	-	-	-	-	-	-	'111111'	-	'0001'
17	2	2	0	-2.328306437	'0'	'0'	'000000'	'00000000'	'0001'
18	2	2	2	-10.24454832	'0'	'0'	'000000'	'00000000'	'0001'
19	-	-	-	-	-	-	'111111'	-	'0001'
20	-	-	-	-	-	-	'000000'	'00000000'	'0001'
21	2	2	2	-2.328306437	'0'	'0'	'000000'	'00000000'	'0001'
22	-	-	-	-	-	-	'111111'	-	'0001'
23	2	2	0	-2.793967724	'0'	'0'	'000000'	'00000000'	'0001'
24	-	-	-	-	-	-	'000000'	'00000000'	'0001'
25	-	-	-	-	-	-	'000000'	'00000000'	'0001'
26	-	-	-	-	-	-	'111111'	-	'0001'
27	-	-	-	-	-	-	'000000'	'00000000'	'0001'
28	-	-	-	-	-	-	'000000'	'00000000'	'0001'
29	2	2	0	-	'0'	'0'	'000000'	'00000000'	'0001'
30	-	-	-	-6.984919309	-	-	'000000'	'00000000'	'0001'

31	2	2	1	-6.053596735	'0'	'0'	'000000'	'00000000'	'0001'
32	-	-	-	-	-	-	'111111'	-	'0001'

1 Notes for Table B.8-1:

2 1. The interpretation of URA is as follows:

3 0 : >2 m

4 1 : >2.8 m

5 2 : >4 m

6 2. The interpretation of SV Health in Frame 25 is as follows:

7 '000000': All Signals OK

8 '111111': Satellite not present

9 3. The interpretation of SV Health in valid Almanac frames is as follows:

10 '00000000': All Data and Signals OK

11 4. The interpretation of Satellite Configuration is as follows:

12 '0001': Block 2 satellite

13



## 1 **Annex C – METHOD OF STATISTICAL CONFIDENCE DETERMINATION**

2 This Annex is normative.

3 The statistical approach, proposed by FCC [20], will be used to determine whether or not a  
4 set of measurement errors resulting from a finite set of measurements demonstrate a  
5 specified accuracy with a specified confidence. Other equivalent methods can also be used  
6 to demonstrate such accuracy.

### 7 **C.1 Description of the Confidence Determination Method**

8 A method for determining whether or not a set of location errors resulting from empirical  
9 testing demonstrates compliance may be obtained from order statistics. Confidence  
10 intervals for a specified accuracy may be selected based on a certain confidence level (for  
11 example, 90% for FCC) and the number of samples. These confidence intervals are not  
12 based on any knowledge of the actual probability distribution function of the location  
13 errors. They are expressed in terms of the subscripts of the list of location errors after  
14 ordering these errors from smallest to largest. A specific set of accuracy measurements is  
15 said to show compliance if the confidence intervals contain the location error thresholds  
16 that may be specified by a Standards Development Organization. For example, the error  
17 thresholds are 100 meters for 67% and 300 meters for 95% for network-based solutions, or  
18 50 meters and 150 meters, respectively for handset-based solutions, as specified by the  
19 FCC ruling [19].

20 In general, when the number of measurements is  $n$ , the  $r^{\text{th}}$  and  $s^{\text{th}}$  largest measurements  
21 are  $x_r$  and  $y_s$  respectively, and  $x$  and  $y$  are the percentile points associated with probabilities  
22  $p_1$  and  $p_2$  respectively, then the probability that  $x$  is less than  $x_r$  while simultaneously  $y$  is  
23 less than  $y_s$  is given by the formula

$$24 \quad \text{Confidence}(x \leq x_r, y \leq y_s; n, r, s, p_1, p_2) = \sum_{i=0}^{r-1} \sum_{j=i}^{s-1} \binom{n}{i} \binom{n-i}{n-j} p_1^i (p_2 - p_1)^{j-i} (1 - p_2)^{n-j}.$$

25 For example,  $p_1$  is 0.67, and  $p_2$  is 0.95 for the FCC ruling [19, 20].

26 Upper bounds on the percentile points can be determined from this expression by finding  
27 pairs of values ( $r, s$ ) such that the desired 90% confidence level is achieved. The resulting  
28 pair of ordered samples ( $x_r, y_s$ ) forms one-sided confidence intervals for the two sample  
29 percentile points associated with 67% and 95%, respectively (see Table C.1-1). The  $r^{\text{th}}$   
30 sample  $x_r$  and  $s^{\text{th}}$  sample  $y_s$  of  $n$  location errors are then compared with 100 meters and 300  
31 meters for the networked-based solutions or with 50 meters and 150 meters for the  
32 handset-based solutions. If the  $r^{\text{th}}$  ordered sample is less than 100 meters and the  $s^{\text{th}}$   
33 ordered sample is less than 300 meters, then the confidence intervals are found to cover  
34 the desired values and compliance would be established, for networked-based solutions. A  
35 similar approach would establish compliance for a set of location errors obtained from a  
36 test of a handset-based solution.

37 The confidence level of 90% is suggested here as a threshold, and the value calculated from  
38 the actual data may be greater. Table C.1-1 is derived from the above confidence

1 expression and shows for several sample sizes which ordered samples of errors should be  
 2 compared with the FCC criteria. For higher numbers of sample sizes such as 500 or 1000,  
 3 the confidence expression should be re-calculated with the higher value of  $n$ .

4 Confidence in the compliance assessment is important and will depend on randomness and  
 5 independence in the selection of test locations. Reports of compliance testing should  
 6 describe the method used to guarantee random and independent accuracy measurements.

7  
 8 **Table C.1-1 Identification of Location Error Samples for Comparison with FCC**  
 9 **Required Thresholds of 67% and 95% (at the 90% Confidence Level)**

Sample Size	Pairs of Test Samples
45	( $x_{40}, y_{45}$ )
50	( $x_{41}, y_{50}$ )
55	( $x_{44}, y_{55}$ )
60	( $x_{47}, y_{60}$ )
65	( $x_{50}, y_{65}$ )
70	( $x_{53}, y_{70}$ )
75	( $x_{57}, y_{75}$ )
80	( $x_{60}, y_{80}$ ) OR ( $x_{63}, y_{79}$ )
85	( $x_{64}, y_{85}$ ) OR ( $x_{66}, y_{84}$ )
90	( $x_{67}, y_{90}$ ) OR ( $x_{68}, y_{89}$ )
95	( $x_{71}, y_{95}$ ) OR ( $x_{72}, y_{94}$ )
100	( $x_{74}, y_{100}$ ) OR ( $x_{75}, y_{99}$ )

## 10 11 C.2 Evaluation Example

12 In the following, an example is given. A handset-based solution would be found in  
 13 compliance, if, in a test of 75 accuracy measurements, the 57<sup>th</sup> largest location error is less  
 14 that 50 meters and the 75<sup>th</sup> largest error is less than 150 meters. Note that for larger  
 15 sample sizes the pair of test samples is not unique, because of the statistical dependence of  
 16 the 67% and 95% levels. For example, for a sample size of 80, two pairs are shown; the  
 17 67% level could be increased from the 60<sup>th</sup> to the 63<sup>rd</sup> sample, (i.e., made more difficult), if  
 18 the 95% level test were relaxed to the 79<sup>th</sup> largest sample. Either ( $x_{60}, y_{80}$ ) or ( $x_{63}, y_{79}$ ) is an  
 19 acceptable pair to test against the FCC-required thresholds.

1 **Annex D PDE SIMULATOR RESPONSE MESSAGES**

2 This Annex is normative.

3 The PDE simulator response messages are included in the attached files.

- 4 1. Annex D Acquisition.txt      636 KB      01/21/2002  
 5 2. Annex D Almanac.txt          2 KB          01/21/2002  
 6 3. Annex D BSAmanac.txt        1 KB          01/21/2002  
 7 4. Annex D BSCapabilities.txt   1 KB          01/21/2002  
 8 5. Annex D Ephemeris.txt        2 KB          01/21/2002  
 9 6. Annex D Location.txt         178 KB       01/21/2002  
 10 7. Annex D Sensitivity.txt       5,332 KB     01/21/2002

11 The PDE simulator response messages presented in this Annex assume the pilot phase  
 12 offset assignment shown in Table D-1. This assignment must be changed and the  
 13 corresponding PDE simulator response message field values corrected accordingly if the test  
 14 equipment used in the tests is configured with a different pilot phase offset assignment.

15  
 16 **Table D-1 Pilot PN Offset and BASE\_ID Assignment Used in the PDE Simulator**  
 17 **Response Messages**

Pilot PN Offset	Numerical Value (in units of 64 CDMA Chips)	BASE_ID (Decimal)
P <sub>0</sub>	0	0
P <sub>1</sub>	1	4
P <sub>2</sub>	2	5
P <sub>3</sub>	3	3
P <sub>4</sub>	4	1
P <sub>5</sub>	5	2
P <sub>6</sub>	6	6
P <sub>7</sub>	7	7
P <sub>8</sub>	8	8
P <sub>9</sub>	9	9

18

19