

**3GPP2 C.S0014-C**

*Version 1.0*

*Date: January 2007*



**3RD GENERATION  
PARTNERSHIP  
PROJECT 2  
"3GPP2"**

1  
2  
3  
4

***Enhanced Variable Rate Codec, Speech Service  
Options 3, 68, and 70 for Wideband Spread  
Spectrum Digital Systems***

COPYRIGHT

3GPP2 and its Organizational Partners claim copyright in this document and individual Organizational Partners may copyright and issue documents or standards publications in individual Organizational Partner's name based on this document. Requests for reproduction of this document should be directed to the 3GPP2 Secretariat at [secretariat@3gpp2.org](mailto:secretariat@3gpp2.org). Requests to reproduce individual Organizational Partner's documents should be directed to that Organizational Partner. See [www.3gpp2.org](http://www.3gpp2.org) for more information.

1  
2  
3  
4  
5  
6  
7  
8  
9  
10  
11

**FOREWORD**

These technical requirements form a standard for Service Options 3, 68, and 70, enhanced variable rate, two way speech service options known as EVRC-A, EVRC-B, and EVRC-WB respectively. These service options communicate at one of four channel rates corresponding to the 9600 bps, 4800 bps, 2400, and 1200 bps frame rates. However, Service Option 3 does not use 2400 bps channel frame rate. The speech coder source bit-rate corresponding to the above mentioned 4 channel rate are 8550, 4000, 2000, and 800 bps. Service Options 68, and 70 have the capability to operate in multiple operating points at different average rates of operation that can be used for obtaining different system capacity while trading off speech quality gracefully.

This standard does not address the quality or reliability of Service Options 3, 68, and 70 nor does it cover equipment performance or measurement procedures.

**NOTES**

1  
2  
3  
4  
5  
6  
7  
8  
9  
10  
11  
12  
13  
14  
15  
16  
17  
18  
19  
20  
21  
22  
23  
24  
25  
26  
27  
28  
29

1. The appropriate version of the Minimum Performance Standard for the enhanced variable rate codecs, EVRC-A, EVRC-B, and EVRC-WB provides specifications and measurement methods.

2. "Base station" refers to the functions performed on the landline side, which are typically distributed among a cell, a sector of a cell, a mobile switching center, and a personal communications switching center.

3. This document uses the following verbal forms: "Shall" and "shall not" identify requirements to be followed strictly to conform to the standard and from which no deviation is permitted. "Should" and "should not" indicate that one of several possibilities is recommended as particularly suitable, without mentioning or excluding others; that a certain course of action is preferred but not necessarily required; or that (in the negative form) a certain possibility or course of action is discouraged but not prohibited. "May" and "need not" indicate a course of action permissible within the limits of the standard. "Can" and "cannot" are used for statements of possibility and capability, whether material, physical, or causal.

4. Footnotes appear at various points in this specification to elaborate and further clarify items discussed in the body of the specification.

5. Unless indicated otherwise, this document presents numbers in decimal form.

Binary numbers are distinguished in the text by the use of single quotation marks. In some tables, binary values may appear without single quotation marks if table notation clearly specifies that values are binary. The character 'x' is used to represent a binary bit of unspecified value. For example 'xxx00010' represents any 8-bit binary value such that the least significant five bits equal '00010'.

Hexadecimal numbers (base 16) are distinguished in the text by use of the form 0x...h, where h...h represents a string of hexadecimal digits. For example, 0x2FA1 represents a number whose binary value is '1011111010001' and whose decimal value is 12913.

1 **NOTES**

26. The following conventions apply to mathematical expressions in this standard:

- 3 •  $\lfloor x \rfloor$  indicates the largest integer less than or equal to  $x$ :  $\lfloor 1.1 \rfloor = 1$ ,  $\lfloor 1.0 \rfloor = 1$ , and  $\lfloor -1.1 \rfloor = -2$ .
- 4 •  $\lceil x \rceil$  indicates the smallest integer greater than or equal to  $x$ :  $\lceil 1.1 \rceil = 2$ ,  $\lceil 2.0 \rceil = 2$ , and  $\lceil -1.1 \rceil = -1$ .
- 5
- 6 •  $|x|$  indicates the absolute value of  $x$ :  $|-17| = 17$ ,  $|17| = 17$ .
- 7 •  $\oplus$  indicates exclusive OR.
- 8 •  $\min(x, y)$  indicates the minimum of  $x$  and  $y$ .
- 9 •  $\max(x, y)$  indicates the maximum of  $x$  and  $y$ .
- 10 • In figures,  $\times$  indicates multiplication. In formulas within the text, multiplication is implicit. For
- 11 example, if  $h(n)$  and  $p_L(n)$  are functions, then  $h(n) p_L(n) = h(n) \times p_L(n)$ .
- 12 •  $x \bmod y$  indicates the remainder after dividing  $x$  by  $y$ :  $x \bmod y = x - (y \lfloor x/y \rfloor)$ .
- 13 •  $\text{round}(x)$  is traditional rounding:  $\text{round}(x) = \text{sign}(x) \lfloor |x| + 0.5 \rfloor$ , where

$$\text{sign}(x) = \begin{cases} 1 & x \geq 0 \\ -1 & x < 0 \end{cases}$$

- 15 •  $\sum$  indicates summation. If the summation symbol specifies initial and terminal values, and the
- 16 initial value is greater than the terminal value, then the value of the summation is 0. For example,
- 17 if  $N=0$ , and if  $f(n)$  represents an arbitrary function, then

$$\sum_{n=1}^N f(n) = 0.$$

- 19 • The bracket operator,  $[ ]$ , isolates individual bits of a binary value.  $\text{VAR}[n]$  refers to bit  $n$  of the
- 20 binary representation of the value of the variable  $\text{VAR}$ , such that  $\text{VAR}[0]$  is the least significant bit
- 21 of  $\text{VAR}$ . The value of  $\text{VAR}[n]$  is either 0 or 1.
- 22 • Unless otherwise specified  $\log(x)$  denotes logarithm at base 10 throughout this document.

1

**NORMATIVE REFERENCES**

<b>Ref.</b>	<b>Document</b>	
<b>Standards</b>		
N1	<i>Upper Layer (Layer 3) Signalling Standard for cdma2000 Spread Spectrum Systems</i>	C.S0005-A, July, 2000
N2	<i>Discontinuous Transmission (DTX) of Speech in cdma2000 Systems</i>	C.S0076-0 v1.0, December 2005
N3	<i>Cellular System Recommended Minimum Performance Standards for Full-Rate Speech Codes (superceded by TIA - 95-B)</i>	TIA/EIA/IS-95, May 1992
N4	<i>Mobile Station-Base Station Compatibility Standard for Wideband Spread Spectrum Cellular Systems</i>	TIA-95-B-04(R2004), October 2004
N5	<i>Introduction to cdma2000 Standards for Spread Spectrum Systems</i>	3GPP2 C.S0001-D, October 2005

2

**INFORMATIVE REFERENCES**

<b>Ref.</b>	<b>Document</b>	
<b>Standards</b>		
S1	<i>Telecommunications Telephone Terminal Equipment Transmission Requirements for Digital Wireline Telephones</i>	ANSI/EIA/TIA-579-A-98
S2	<i>Pulse Code Modulation (PCM) of Voice Frequencies</i>	ITU-T Recommendation G.711, November 1988
S3	<i>Transmission Performance Characteristics of Pulse Code Modulation</i>	ITU-T Recommendation G.712, November 2001
S4	<i>IEEE Standard Methods for Measuring Transmission Performance of Analog and Digital Telephone Sets</i>	IEEE Standard 269-2002, 2002
S5	<i>Method for Determining Objective Loudness Ratings of Telephone Connections</i>	IEEE Standard 661-1979, 1979
S6	<i>Minimum Performance Specification for the Enhanced Variable Rate Codec, Speech Service Option 3 for Spread Spectrum Digital Systems</i>	C.S0018-0 v1.0, December, 1999
S7a	<i>Enhanced Variable Rate Codec, Speech Service Option 3 for Wideband Spread Spectrum Digital Systems</i>	C.S0014-0 v1.0, December, 1999
S7b	<i>Enhanced Variable Rate Codec, Speech Service Option 3 for Wideband Spread Spectrum Digital Systems</i>	C.S0014-0 v3.0, May, 2001
S8	<i>Enhanced Variable Rate Codec, Speech Service Option 3 for Wideband Spread Spectrum Digital Systems</i>	C.S0014-A v1.0, May, 2004

Ref.	Document	
S9	<i>Digital network echo cancellers</i>	ITU-T Recommendation G.168, August 2004
S10	<i>Operational and interworking requirements for DCEs operating in the text telephone mode</i>	ITU-T Recommendation V.18, November 2000
S11	<i>Transmission Characteristics for Wideband (150-7000 Hz) Digital Handset Telephones.</i>	ITU-T Recommendation P.311, February, 1998
S12	<i>Transmission Characteristics for Wideband (150-7000 Hz) Digital Hands-free Telephony Terminals.</i>	ITU-T Recommendation P.341, February, 1998
<b>Resources</b>		
R1	<i>Proakis, J. G. and Manolakis, D. G., Introduction to Digital Signal Processing, New York, Macmillan</i>	1988, pp. 721-722
R2	<i>Rabiner, L. R. and Schafer, R. W., Digital Processing of Speech Signals</i>	New Jersey, Prentice-Hall Inc., 1978
R3	<i>Crochiere, R. E. and Rabiner L. R., Multirate Digital Signal Processing</i>	New Jersey, Prentice-Hall Inc., 1983
R4	<i>Oppenheim, A. V. and Schafer, R. W., Digital Signal Processing</i>	New Jersey, Prentice-Hall Inc., 1975
R5	<i>Proakis, J. G. and Manolakis, D. G., Introduction to Digital Signal Processing</i>	New York, Macmillan, 1988
R6	<i>Dellar, J. R., Proakis, J. G., Hansen, J. H. L., Discrete-Time Processing of Speech Signals</i>	New York, Macmillan, 1993
R7	<i>Alejandro, A., Acoustical and Environmental Robustness in Automatic Speech Recognition</i>	Boston, Kluwer Academic Publishers, 1993
R8	<i>Kleijn, W. B., Kroon, P., and Nahumi, D., The RCELP Speech-Coding Algorithm,</i>	European Transactions on Telecommunications, Vol 5, No 5. Sept/Oct 1994, pp 573-582
R9	<i>Nahumi, D and Kleijn, W. B., An Improved 8 kb/s RCELP Coder,</i>	IEEE Workshop on Speech Coding, 1995
R10	<i>Atal, B. S. and Schroeder, M. R., Stochastic coding of speech at very low bit rates</i>	Proc Int. Conf. Comm., Amsterdam, 1984, pp 1610-1613
R11	<i>Laflamme, C., Adoul, J-P., Salami, R., Morissette, S., and Mabillean, P., 16 kbps wideband speech coding technique based on algebraic CELP</i>	Proc. ICASSP 1991, pp. 13-16
R12	<i>Salami, R., Laflamme, C., Adoul, J-P., et.al, A Toll Quality 8 kbits Speech coder for Personal Communication Systems (PCS)</i>	IEEE Trans. on Vehicle Technology, 1994
R13	<i>Ashley, J.P., Cruz-Zeno, E.M., Mittal, U., Peng, W., Wideband coding of speech using a scalable pulse codebook,</i>	2000 IEEE Workshop on Speech Coding, September 2000, pp 148-150.

Ref.	Document	
R14	<i>Gerson, I.A.; Jasiuk, M.A., Techniques for improving the performance of CELP-type speech coders</i>	Selected Areas in Communications, IEEE Journal, Volume 10, Issue 5, June 1992 Page(s):858 - 865
R15	<i>U. Mittal, J. P. Ashley, and E. M. Cruz-zeno, Low Complexity Joint Optimization of Excitation Parameters in Analysis-by-Synthesis Speech Coding</i>	Proceedings Eurospeech 2003, pp. 1261-1264

1

**REVISION HISTORY**

<b>Revision</b>	<b>Description</b>	<b>Date</b>
C.S0014-0 v1.0 & v2.0 [S7a]	Release 0, Enhanced Variable Rate Coder Algorithm Description for Service Option 3	December, 1999
C.S0014-0 v3.0 [S7b]	Release 3, Enhanced Variable Rate Coder Algorithm Description for Service Option 3	May, 2001
C.S0014-A v1.0 [S8]	Release A, Enhanced Variable Rate Coder Algorithm Description for Service Option 3	May, 2004
C.S0014-B v1.0	Release B, Enhanced Variable Rate Coder Algorithm Description for Service Options 3 and 68	May, 2006
C.S0014-C v1.0	Release C, Enhanced Variable Rate Coder Algorithm Description for Service Options 3, 68, and 70	January, 2007

2

1	TABLE OF CONTENTS	
2	1 GENERAL .....	1-1
3	1.1 General Description .....	1-1
4	1.2 Service Option Number .....	1-1
5	1.3 Allowable Delays .....	1-1
6	1.3.1 Allowable Transmitting Speech Codec Encoding Delay .....	1-1
7	1.3.2 Allowable Receiving Speech Codec Decoding Delay .....	1-1
8	1.4 Special Cases.....	1-2
9	1.4.1 Blanked Packets .....	1-2
10	1.4.2 Null Traffic Channel Data .....	1-2
11	1.4.3 All Zeros Packet.....	1-2
12	1.5 Terms and Numeric Information.....	1-2
13	2 Required Multiplex Option Support .....	2-1
14	2.1 Interface to Multiplex Option 1.....	2-1
15	2.1.1 Transmitted Packets .....	2-1
16	2.1.2 Received Packets .....	2-1
17	2.2 Negotiation for Service Option 3 .....	2-2
18	2.2.1 Procedures Using Service Option Negotiation .....	2-2
19	2.2.1.1 Initialization and Connection.....	2-2
20	2.2.1.1.1 Initialization and Connection in the Mobile Station.....	2-2
21	2.2.1.1.2 Initialization and Connection in the Base Station .....	2-3
22	2.2.1.2 Service Option Control Orders .....	2-4
23	2.2.2 Procedures Using Service Negotiation .....	2-5
24	2.2.2.1 Initialization and Connection.....	2-6
25	2.2.2.1.1 Mobile Station Requirements.....	2-6
26	2.2.2.1.2 Base Station Requirements.....	2-6
27	2.2.2.2 Service Option Control Messages.....	2-6
28	2.2.2.2.1 Mobile Station Requirements.....	2-6
29	2.2.2.2.2 Base Station Requirements.....	2-7
30	2.3 Service Option Group Assignments.....	2-9
31	2.4 Negotiation for Service Option 68.....	2-9
32	2.4.1 Procedures using service negotiation.....	2-9

1	2.4.1.1	Initialization and connection.....	2-10
2	2.4.1.2	Service option control messages.....	2-11
3	2.5	Negotiation for Service Option 70.....	2-14
4	2.5.1	Procedures using service negotiation.....	2-14
5	2.5.1.1	Initialization and connection.....	2-15
6	2.5.1.2	Service option control messages.....	2-16
7	<b>3</b>	<b>Audio Interfaces.....</b>	<b>3-1</b>
8	3.1	Input Audio Interface.....	3-1
9	3.1.1	Input Audio Interface in the Mobile Station.....	3-1
10	3.1.1.1	Conversion and Scaling.....	3-1
11	3.1.1.2	Digital Audio Input.....	3-1
12	3.1.1.3	Analog Audio Input.....	3-1
13	3.1.1.3.1	Transmit Level Adjustment.....	3-1
14	3.1.1.3.2	Band Pass Filtering.....	3-1
15	3.1.1.3.3	Echo Return Loss.....	3-1
16	3.1.2	Input Audio Interface in the Base Station.....	3-2
17	3.1.2.1	Sampling and Format Conversion.....	3-2
18	3.1.2.2	Transmit Level Adjust.....	3-2
19	3.1.2.3	Line Echo Canceling.....	3-2
20	3.2	Output Audio Interface.....	3-2
21	3.2.1	Output Audio Interface in the Mobile Station.....	3-2
22	3.2.1.1	Band Pass Filtering.....	3-2
23	3.2.1.2	Receive Level Adjustment.....	3-2
24	3.2.2	Output Audio Interface in the Base Station.....	3-3
25	3.2.2.1	Receive Level Adjustment.....	3-3
26	<b>4</b>	<b>Overview AND SPEECH ENCODER.....</b>	<b>4-1</b>
27	4.1	Service Option 3.....	4-1
28	4.2	Service Option 68.....	4-3
29	4.2.1	Pre-processing.....	4-6
30	4.2.2	Rate/coding scheme decision.....	4-7
31	4.2.2.1	Open-loop decision.....	4-7
32	4.2.2.2	Closed-loop decision.....	4-7

1	4.2.2.3	Operating point-switching and dimming .....	4-7
2	4.2.2.4	Arbitrary capacity operating point operation .....	4-8
3	4.2.3	Full-rate CELP and half-rate CELP .....	4-9
4	4.2.4	Full-rate PPP and quarter-rate PPP and special Half-rate PPP .....	4-10
5	4.2.4.1	Background .....	4-10
6	4.2.4.2	PPP Model .....	4-11
7	4.2.4.3	Further processing of PPP frames .....	4-12
8	4.2.4.4	Amplitude Quantization .....	4-12
9	4.2.4.5	Phase Quantization .....	4-14
10	4.2.4.6	Special half-rate PPP frame .....	4-16
11	4.2.4.7	Detection of outliers .....	4-17
12	4.2.5	Frame erasure handling .....	4-17
13	4.2.6	Bad rate/packet handling .....	4-17
14	4.3	Service Option 70 .....	4-17
15	4.3.1	Leverage FROM EVRC-B to obtain EVRC-WB-LB .....	4-19
16	4.3.2	Bit Allocation .....	4-20
17	4.3.3	Coding the High-Frequency Band Of Wideband Speech .....	4-20
18	4.3.3.1	Click Remover .....	4-20
19	4.3.3.2	High-Band Analysis .....	4-20
20	4.3.3.3	High-Band Excitation Generation .....	4-21
21	4.3.4	Silence Encoder .....	4-23
22	4.3.5	Decoder Details .....	4-23
23	4.4	Input Signal Preprocessing .....	4-23
24	4.4.1	Fast Automatic Gain Control for Wideband Inputs .....	4-23
25	4.4.2	High-Pass Filter .....	4-24
26	4.4.3	Noise Suppression .....	4-25
27	4.4.3.1	Frequency Domain Conversion .....	4-27
28	4.4.3.2	Channel Energy Estimator .....	4-28
29	4.4.3.3	Channel SNR Estimator .....	4-29
30	4.4.3.4	Voice Metric Calculation .....	4-29
31	4.4.3.5	Band SNRs for Rate Determination Algorithm .....	4-30
32	4.4.3.6	Spectral Deviation Estimator .....	4-30

1	4.4.3.7	Peak-to-Average Ratio.....	4-31
2	4.4.3.8	Background Noise Update Decision.....	4-31
3	4.4.3.9	SNR Estimate Modification.....	4-32
4	4.4.3.10	SNR Variability Estimator.....	4-33
5	4.4.3.11	Channel Gain Computation.....	4-33
6	4.4.3.12	Frequency Domain Filtering.....	4-34
7	4.4.3.13	Background Noise Estimate Update.....	4-34
8	4.4.3.14	Time Domain Signal Reconstruction.....	4-35
9	4.4.3.15	Zero Delay Overlap/Add.....	4-35
10	4.5	Analysis Filterbank.....	4-36
11	4.5.1	Generation of the lowband signal, $S_{LB}$ .....	4-36
12	4.5.2	Generation of the highband signal, $S_{HB}$ .....	4-36
13	4.5.2.1	Interpolation to 32 kHz.....	4-36
14	4.5.2.2	Resampling to 28 KHz.....	4-37
15	4.5.2.3	Decimation to 14 Khz.....	4-37
16	4.5.2.4	Spectral reversal.....	4-37
17	4.5.2.5	Decimation to 7 Khz.....	4-37
18	4.5.2.6	Spectral Shaping.....	4-38
19	4.6	Model Parameter Estimation.....	4-38
20	4.6.1	Formant Filter Parameter Calculation.....	4-39
21	4.6.1.1	Direct Form LPC Parameter Calculation.....	4-39
22	4.6.1.2	Generation of Spectral Transition Indicator ( <i>LPCFLAG</i> ).....	4-41
23	4.6.1.3	Direct Form LPC to LSP Conversion.....	4-41
24	4.6.2	Generation of the Short-Term Prediction Residual.....	4-42
25	4.6.2.1	LSP Interpolation.....	4-43
26	4.6.2.2	LSP to Direct Form LPC Conversion.....	4-43
27	4.6.2.3	Generation of Residual Samples.....	4-44
28	4.6.3	Calculation of the Delay Estimate and Long-Term Prediction Gain.....	4-44
29	4.6.3.1	Non-exhaustive Open Loop Delay Search.....	4-45
30	4.6.3.2	Refinement of open loop delay estimate for SO 3.....	4-45
31	4.6.3.3	Refinement of open loop delay estimate for SO 68 and SO 70.....	4-46
32	4.6.3.4	Long-Term Prediction Gain Calculation.....	4-46

1	4.6.3.5	Smoothed Delay Estimate and LTP Gain for SO3 .....	4-47
2	4.6.3.6	Smoothed delay estimate and LTP gain for SO 68 and SO 70.....	4-47
3	4.6.3.7	Composite Delay and Gain Calculations for SO 3 .....	4-48
4	4.6.3.8	Composite delay and gain calculations for SO 68 and SO 70 .....	4-48
5	4.7	Determining the Data Rate for SO 3 and Voice Activity Detection for SO 68 and SO 70.....	4-49
6	4.7.1	Estimating the Data Rate Based on Current Signal Parameters.....	4-50
7	4.7.1.1	Computing Band Energy .....	4-50
8	4.7.1.2	Calculating Rate Determination Thresholds.....	4-51
9	4.7.1.2.1	SO 3.....	4-52
10	4.7.1.2.2	SO 68 and SO 70.....	4-52
11	4.7.1.3	Comparing Thresholds.....	4-53
12	4.7.1.4	Performing Hangover .....	4-53
13	4.7.1.4.1	Hangover Table for SO 3 .....	4-54
14	4.7.1.4.2	Hangover Table for SO 68 and SO 70 .....	4-54
15	4.7.1.5	Constraining Rate Selection.....	4-56
16	4.7.2	Updating RDA Parameters.....	4-56
17	4.7.2.1	Updating the Smoothed Band Energy.....	4-56
18	4.7.2.2	Updating the Background Noise Estimate.....	4-56
19	4.7.2.3	Updating the Signal Energy Estimate.....	4-57
20	4.8	Mode decision and Rate decision for SO 68 and SO 70.....	4-57
21	4.8.1	Pitch-based NACF .....	4-57
22	4.8.2	Pitch based NACF computation.....	4-59
23	4.8.2.1	Decimation of formant residual (current frames and look-ahead frames) .....	4-59
24	4.8.2.2	NACF Computation for the two subframes of current frame .....	4-59
25	4.8.2.3	NACF computation for the look-ahead frame .....	4-59
26	4.8.3	Speech Coding Mode decision algorithm .....	4-60
27	4.8.3.1	Energy and zero crossing rate.....	4-61
28	4.8.4	Rate-decision for SO 68 and SO 70.....	4-71
29	4.8.4.1	Constraining Rate Selection.....	4-71
30	4.9	Quantization of LSP Parameters for SO 3 .....	4-71
31	4.9.1	Computation of Weights.....	4-73
32	4.9.2	Error Matrix Computation .....	4-73

1	4.9.3	Adjustment of Quantization Error.....	4-73
2	4.9.4	Quantization Search.....	4-74
3	4.9.5	Generation of Quantized LSP Parameters.....	4-74
4	4.10	Quantization of LSP Parameters for SO 68 and SO 70.....	4-74
5	4.10.1	Full-rate, half-rate, and quarter-rate unvoiced: delta LSP VQ.....	4-74
6	4.10.2	Full rate LSP and SO 70 Unvoiced Half Rate LSP VQ.....	4-75
7	4.10.3	Half Rate LSPVQ for SO 68 and SO 70 NB Mode.....	4-77
8	4.10.4	Quarter rate unvoiced LSPVQ for SO 68.....	4-78
9	4.10.5	Quarter-rate Voiced LSPVQ for SO 68.....	4-79
10	4.10.5.1	QPPP LSP quantization Weight Computation.....	4-79
11	4.10.5.2	Constructing the MAVQ memory during frames that are not QPPP.....	4-79
12	4.10.6	Eighth-rate LSPVQ for SO 68 and SO 70 NB mode.....	4-80
13	4.10.7	Eighth-rate LSPVQ SO 70 WB mode.....	4-80
14	4.11	Encoding at Rates 1/2 and 1 for SO 3, SO 68, and SO 70.....	4-80
15	4.11.1	LSP Quantization.....	4-82
16	4.11.2	RCELP Shift State Update.....	4-82
17	4.11.3	Delay Encoding.....	4-83
18	4.11.4	Rates 1/2 and 1 Subframe Processing.....	4-83
19	4.11.4.1	Interpolation of LSP Parameters.....	4-83
20	4.11.4.2	LSP to LPC Conversion.....	4-84
21	4.11.4.3	Interpolated Delay Estimate Calculation.....	4-84
22	4.11.4.4	Modification of the Original Residual.....	4-84
23	4.11.4.5	Generation of the Weighted Modified Original Speech Vector.....	4-84
24	4.11.4.6	Zero Input Response Calculation.....	4-86
25	4.11.4.7	Impulse Response Calculation.....	4-86
26	4.11.4.8	Calculation of the Adaptive Codebook Contribution.....	4-86
27	4.11.4.9	Closed-Loop Gain Calculation.....	4-86
28	4.11.4.10	Fixed Codebook Search Target Vector Generation.....	4-87
29	4.11.4.10.1	Perceptual Domain Target Vector.....	4-87
30	4.11.4.10.2	Conversion of the Target Vector to the Residual Domain.....	4-88
31	4.11.4.10.3	Delay Calculation for Current Subframe.....	4-88
32	4.11.4.11	Fixed Codebook Search.....	4-88

1	4.11.4.12	Fixed codebook gain quantization .....	4-88
2	4.11.4.13	Combined Excitation Vector Computation .....	4-90
3	4.11.4.14	Excitation Input to Highband Analysis (SO 70 wideband mode).....	4-90
4	4.11.4.15	Encoder State Variable Update .....	4-90
5	4.11.5	Computation of the Adaptive Codebook Contribution.....	4-91
6	4.11.5.1	Delay Contour Computation .....	4-92
7	4.11.5.2	Mapping of the Adaptive Codebook to the Delay Contour .....	4-92
8	4.11.5.3	Closed Loop Delay Contour Adjustment.....	4-92
9	4.11.6	Modification of the Residual .....	4-94
10	4.11.6.1	Mapping of the Past Modified Residual to the Delay Contour.....	4-95
11	4.11.6.2	Calculation of the Residual Shift Frame Parameters .....	4-95
12	4.11.6.2.1	Search for Pulses in the Subframe Residual.....	4-96
13	4.11.6.2.2	Location of the First Pulse in the Residual.....	4-96
14	4.11.6.2.3	Location of a Pulse Inside of the Lag Window .....	4-97
15	4.11.6.2.4	Shift Frame Boundary Calculation .....	4-97
16	4.11.6.2.5	Shift Decision.....	4-98
17	4.11.6.2.6	Peak to Average Ratio Calculation .....	4-98
18	4.11.6.3	Matching the Residual to the Delay Contour.....	4-99
19	4.11.6.3.1	Computation of the Shift Range .....	4-99
20	4.11.6.3.2	Generation of a Temporary Modified Residual Signal for Matching.....	4-100
21	4.11.6.3.3	Matching the Temporary Modified Residual to the Target Residual .....	4-100
22	4.11.6.3.4	Adjustment of the Accumulated Shift .....	4-100
23	4.11.6.4	Modification of the Residual .....	4-101
24	4.11.6.5	Modified Target Residual Update.....	4-102
25	4.11.7	Computation of the ACELP Fixed Codebook Contribution for SO 3.....	4-102
26	4.11.7.1	Algebraic Codebook Structure, Rate 1 .....	4-102
27	4.11.7.2	Algebraic Codebook Search .....	4-104
28	4.11.7.2.1	Pre-setting of Pulse Signs.....	4-105
29	4.11.7.2.2	Non-Exhaustive Pulse Position Search .....	4-105
30	4.11.7.3	Codeword Computation of the Algebraic Codebook.....	4-106
31	4.11.7.4	Algebraic Codebook Structure, Rate 1/2 .....	4-107
32	4.11.8	Computation of the Factorial fixed codebook contribution for SO 68 and SO 70.....	4-108

1	4.11.8.1	Fixed codebook (FCB) structure, Rate 1 .....	4-109
2	4.11.8.2	Codebook search.....	4-110
3	4.11.8.2.1	Pre-setting of pulse signs.....	4-112
4	4.11.8.2.2	Non-exhaustive pulse position search .....	4-112
5	4.11.8.3	Codeword computation of the factorial codebook.....	4-112
6	4.11.8.4	Converting a code-word to a code-vector.....	4-115
7	4.11.8.5	Codebook structure, Rate 1/2.....	4-116
8	4.11.8.5.1	Converting a Rate 1/2 code-word to a code-vector .....	4-120
9	4.11.8.6	Fixed Codebook Gain Calculation.....	4-121
10	4.12	Voiced encoding (full-rate PPP and quarter-rate PPP).....	4-121
11	4.12.1	Modification of the original residual.....	4-121
12	4.12.2	Prototype pitch period processing .....	4-121
13	4.12.3	Alignment extraction between two DFS, $X_1$ , and $X_2$ .....	4-122
14	4.12.4	Pole-filtering a DFS.....	4-122
15	4.12.5	Zero-filtering a DFS .....	4-123
16	4.12.6	Applying a phase shift to a DFS.....	4-123
17	4.12.7	Energy of a DFS, $X$ .....	4-124
18	4.12.8	Converting a DFS from Cartesian to polar representation .....	4-124
19	4.12.9	Converting a DFS from polar to Cartesian representation .....	4-124
20	4.12.10	Normalizing the band energy of a DFS in polar representation .....	4-124
21	4.12.11	Converting the DFS amplitudes to equivalent rectangular bandwidth (ERB) amplitudes ..	4-125
22	4.12.12	LPC power-spectrum.....	4-125
23	4.12.13	Current to previous PPP energy ratio .....	4-126
24	4.12.14	Full search alignment between two DFS.....	4-126
25	4.12.15	Fine search alignment between two DFS .....	4-126
26	4.12.16	Weighted alignment search between two DFS, $X_1$ and $X_2$ .....	4-126
27	4.12.17	Zero padding a DFS to have the same lag as another DFS .....	4-127
28	4.12.18	Band-limited correlation between two DFS .....	4-127
29	4.12.19	Speech domain energy of a DFS .....	4-127
30	4.12.20	Grouping DFS harmonics into ERB slots .....	4-128
31	4.12.21	Zero inserting into a DFS .....	4-128
32	4.12.22	Peak to average ratio of PPP from its DFS.....	4-129

1	4.12.23	Converting ERB amplitudes to DFS amplitudes.....	4-129
2	4.12.24	Prototype pitch period extraction .....	4-129
3	4.12.25	Restoring PPP memories if last frame is non-PPP or full-rate PPP.....	4-131
4	4.12.26	Correlation between current and previous PPP.....	4-131
5	4.12.27	Open-loop coding scheme change.....	4-131
6	4.12.28	Quarter-rate PPP quantization .....	4-132
7	4.12.28.1	Delta delay quantization .....	4-132
8	4.12.28.2	ERB differential amplitude quantization .....	4-132
9	4.12.28.3	ERB differential amplitude dequantization.....	4-135
10	4.12.28.4	Evaluating the quality of quantization .....	4-136
11	4.12.28.5	Obtaining the dequantized current PPP DFS .....	4-136
12	4.12.28.6	Copying the phase spectrum of previous PPP DFS .....	4-137
13	4.12.28.7	Closed loop bump-up from QPPP to full-rate CELP coding scheme .....	4-137
14	4.12.29	FPPP DFS amplitude vector quantization .....	4-138
15	4.12.29.1	ERB amplitude dequantization .....	4-140
16	4.12.29.2	Phase quantization .....	4-141
17	4.12.29.2.1	Global alignment .....	4-141
18	4.12.29.2.2	Band alignment .....	4-142
19	4.12.30	PPP synthesis.....	4-143
20	4.12.30.1	Calculating the expected alignment shift .....	4-144
21	4.12.30.2	Computing the actual alignment shift and shifting the current PPP .....	4-144
22	4.12.30.3	Computation of the cubic phase track for the synthesis of one frame of residual .....	4-144
23	4.12.30.4	Generating the whole frame of residual.....	4-145
24	4.12.31	Perceptual weighting filter update.....	4-145
25	4.13	Encoding at Rate 1 Generic Audio for SO 70 .....	4-145
26	4.13.1	LPC Analysis/Quantization.....	4-146
27	4.13.2	Short-Term Residual Generation.....	4-146
28	4.13.3	Formant Emphasis.....	4-147
29	4.13.4	Modified Discrete Cosine Transform (MDCT).....	4-147
30	4.13.5	MDCT Residual Line Spectrum Quantization .....	4-147
31	4.13.6	Global Scale Factor Quantization.....	4-149
32	4.13.7	Noise Injection .....	4-150

1	4.13.8	Inverse Modified Discrete Cosine Transform (IMDCT).....	4-150
2	4.13.9	Formant Deemphasis .....	4-151
3	4.14	Encoding at Rate $\frac{1}{4}$ unvoiced for SO 68 and Rate $\frac{1}{2}$ unvoiced for SO 70 WB .....	4-151
4	4.14.1	Computation and quantization of gains.....	4-152
5	4.14.2	Random number generation .....	4-153
6	4.14.3	Creation of sparse nonzero excitation .....	4-154
7	4.14.4	Shaping the excitation .....	4-154
8	4.14.5	Perceptual weighting filter update.....	4-156
9	4.15	Encoding at Rate 1/8 .....	4-156
10	4.15.1	LSP Quantization .....	4-156
11	4.15.2	Interpolation of LSP Parameters .....	4-156
12	4.15.3	LSP to LPC Conversion .....	4-156
13	4.15.4	Impulse Response Computation.....	4-157
14	4.15.5	Calculation of the Frame Energy Gain for SO 3 .....	4-157
15	4.15.6	Gain Quantization for SO 3.....	4-157
16	4.15.7	Calculation of the frame energy gain .....	4-158
17	4.15.8	Gain quantization for SO 68 and SO 70 NB mode .....	4-159
18	4.15.9	Gain quantization for SO 70 WB mode .....	4-160
19	4.15.10	Generation of Rate 1/8 Excitation .....	4-160
20	4.15.11	Perceptual Weighting Filter Update .....	4-160
21	4.16	Random Number Generation.....	4-160
22	4.16.1	Uniform Pseudo-Random Number Generation Algorithm.....	4-160
23	4.16.2	Gaussian Pseudo-Random Number Generator .....	4-161
24	4.17	Discontinuous Transmission.....	4-162
25	4.18	Coding the High-Frequency Band Of Wideband Speech.....	4-162
26	4.18.1	Declick Algorithm.....	4-162
27	4.18.2	High-Band LPC Analysis and Quantization.....	4-164
28	4.18.3	High-Band Excitation Generation .....	4-164
29	4.18.4	Computation and Quantization of gains for high-band excitation .....	4-166
30	4.19	Packet Formatting for SO 3 .....	4-166
31	4.20	Packet Formatting for SO 68.....	4-170
32	4.20.1	Special Half NELP frame.....	4-175

1	4.20.2	Packet Level Signaling Interworking Function.....	4-175
2	4.21	Packet Formatting for SO 70.....	4-175
3	4.21.1	Packet Level Signaling Interworking Function.....	4-180
4	5	Speech Decoder .....	5-1
5	5.1	Frame Error Detection.....	5-1
6	5.1.1	Received Packet Type Processing for SO 3.....	5-2
7	5.1.2	Received Packet Type Processing for SO 68.....	5-3
8	5.1.3	Received Packet Type Processing for SO 70 (in WB mode).....	5-4
9	5.1.4	Packet Sanitycheck for Badrate Detection for SO 3 .....	5-4
10	5.1.4.1	Delay Parameter Checking .....	5-4
11	5.1.4.2	Delta Delay Parameter Checking.....	5-4
12	5.1.5	Packet Sanitycheck for Badrate Detection for SO 68 .....	5-4
13	5.1.5.1	Delay parameter checking.....	5-4
14	5.1.5.2	Delta delay parameter checking.....	5-5
15	5.1.5.3	LSP checking.....	5-5
16	5.1.5.4	Unused bit checking .....	5-5
17	5.1.5.5	Invalid filter ID.....	5-5
18	5.1.5.6	Invalid transition.....	5-5
19	5.2	Rate 1/2 and 1 CELP Decoding for SO 3, SO 68, and SO 70 .....	5-5
20	5.2.1	Decoding of the LSP Parameters .....	5-6
21	5.2.2	Delay Decoding and Frame Erasure Delay Contour Reconstruction.....	5-6
22	5.2.2.1	Delay Decoding .....	5-6
23	5.2.2.2	Frame Erasure Delay Contour Reconstruction for Rate 1 for SO 3.....	5-7
24	5.2.2.3	Frame erasure delay contour reconstruction for Rate 1 good frame following an Erased Frame for SO 68	5-7
25			
26	5.2.2.3.1	Delay Reconstruction .....	5-7
27	5.2.2.3.2	Reconstruction of the Delay Contour.....	5-8
28	5.2.2.3.3	Warping of the Adaptive Codebook Memory.....	5-8
29	5.2.2.4	Frame erasure delay contour reconstruction for Rate 1 good frame following a QPPP frame which follows an Erased Frame in SO 68	5-8
30			
31	5.2.2.4.1	Delay reconstruction .....	5-8
32	5.2.2.4.2	Reconstruction of the delay contour.....	5-9
33	5.2.2.4.3	Warping of the adaptive codebook memory .....	5-9

1	5.2.2.5	Smoothing of the Decoded Delay .....	5-9
2	5.2.3	Rates 1/2 and 1 Subframe Decoding .....	5-9
3	5.2.3.1	Interpolation of LSP Parameters .....	5-9
4	5.2.3.2	LSP to LPC Conversion .....	5-10
5	5.2.3.3	Bandwidth Expansion .....	5-10
6	5.2.3.4	Interpolated Delay Estimate Calculation. ....	5-10
7	5.2.3.5	Calculation of the Adaptive Codebook Contribution .....	5-10
8	5.2.3.5.1	SO 3 .....	5-10
9	5.2.3.5.2	SO 68 .....	5-11
10	5.2.3.6	Calculation of the Fixed Codebook Gain .....	5-11
11	5.2.3.7	Computing of the Reconstructed ACELP Fixed Codebook Excitation for SO 3 .....	5-11
12	5.2.3.8	Computing of the reconstructed fixed codebook excitation in SO 68 .....	5-12
13	5.2.3.9	Decoder Total Excitation Generation .....	5-12
14	5.2.3.10	Adaptive Codebook Memory Update .....	5-12
15	5.2.3.11	Additional Excitation Frame Processing .....	5-13
16	5.2.3.12	Frame expansion or compression in CELP frames in SO 68 .....	5-13
17	5.2.3.13	PPP smoothing of CELP frame after erasure in SO 68 .....	5-14
18	5.2.3.14	Pitch Prefilter (SO 70 WB mode) .....	5-14
19	5.2.3.15	Synthesis of the decoder output signal .....	5-15
20	5.2.3.16	Synthesis of the Decoder Output Signal .....	5-15
21	5.3	Rate 1 and Rate 1/4 PPP decoding (FPPP and QPPP) for SO 68 .....	5-15
22	5.3.1	Decoding of the LSP parameters in FPPP .....	5-15
23	5.3.2	Decoding of the LSP parameters in QPPP .....	5-15
24	5.3.3	Delay decoding in FPPP .....	5-16
25	5.3.4	Delay decoding in QPPP .....	5-16
26	5.3.5	Previous frame delay PPP (QPPP and FPPP) .....	5-16
27	5.3.6	Interpolation of LSP parameters and LSP to LPC conversion .....	5-16
28	5.3.7	Restoring PPP memories if last frame is non-PPP or full-rate PPP .....	5-17
29	5.3.8	ERB amplitude dequantization of full-rate PPP .....	5-17
30	5.3.9	Phase dequantization of full-rate PPP or Special Half-rate PPP (packet level signaling) frame .....	5-17
31	5.3.10	Obtaining the dequantized current DFS in QPPP .....	5-18
32	5.3.11	Copying the phase spectrum of previous PPP DFS .....	5-18

1	5.3.12	PPP synthesis.....	5-19
2	5.3.12.1	Frame expansion or compression in PPP synthesis .....	5-19
3	5.3.13	Synthesis of the decoder output signal in PPP .....	5-19
4	5.4	Decoding at Rate 1 Generic Audio for SO 70.....	5-19
5	5.4.1	MDCT Residual Line Spectrum Decoding .....	5-20
6	5.4.2	Global Scale Factor Decoding .....	5-20
7	5.4.3	Noise Injection Decoding .....	5-20
8	5.4.4	Inverse Modified Discrete Cosine Transform (IMDCT) .....	5-21
9	5.4.5	Formant Deemphasis.....	5-21
10	5.5	Decoding of rate 1/4 unvoiced decoding or special rate-1/2 NELP decoding SO 68 and rate 1/2 unvoiced decoding SO 70.....	5-21
11			
12	5.5.1	Frame expansion or compression in Rate 1/4 NELP decoding.....	5-22
13	5.6	Rate 1/8 Decoding.....	5-22
14	5.6.1	Decoding of the LSP parameters .....	5-22
15	5.6.2	Decoding of the Frame Energy Vector for SO 3 .....	5-22
16	5.6.3	Decoding of the Frame Energy Gain for SO 68 and SO 70 NB mode .....	5-23
17	5.6.4	Decoding of the Frame Energy Gain for SO 70 WB mode .....	5-23
18	5.6.5	Rate 1/8 Subframe Decoding .....	5-24
19	5.6.5.1	Rate 1/8 Excitation Generation.....	5-24
20	5.6.5.2	Interpolation of LSP Parameters.....	5-24
21	5.6.5.3	LSP to LPC conversion .....	5-24
22	5.6.5.4	Estimation of the LPC Prediction Gain (for SO 70 WB mode).....	5-24
23	5.6.5.5	Synthesis of Decoder Output Signal.....	5-25
24	5.7	Suppressed/Blanked Rate 1/8 decoding SO 68 and SO 70 .....	5-25
25	5.7.1	Synthesizing comfort noise.....	5-26
26	5.7.2	Generating encoded packet from synthesized noise .....	5-27
27	5.8	Adaptive Postfilter for SO 3.....	5-28
28	5.8.1	Tilt Compensation Filter .....	5-28
29	5.8.2	The Short Term Residual Filter .....	5-29
30	5.8.3	The Long-term Postfilter.....	5-29
31	5.8.4	Gain Normalization and Short-Term Postfilter.....	5-30
32	5.9	Adaptive post filter for SO 68.....	5-30
33	5.9.1	The short-term residual filter .....	5-32

1	5.9.2	The long-term post filter .....	5-32
2	5.9.3	Gain normalization and short-term post filter .....	5-32
3	5.10	Background Noise Estimation (for SO 68).....	5-33
4	5.10.1	Frequency Domain Conversion.....	5-34
5	5.10.2	Channel Energy Estimator.....	5-34
6	5.10.3	Background Noise Estimate .....	5-35
7	5.11	Background Noise Estimation (SO 70 in WB mode).....	5-36
8	5.11.1	Frequency Domain Conversion.....	5-37
9	5.11.2	Channel Energy Estimator.....	5-38
10	5.11.3	Background Noise Estimate .....	5-39
11	5.11.4	Suppressed Eighth Rate Likelihood predictor .....	5-39
12	5.12	Generation of High band signal for 16 KHz decoding for SO 70 .....	5-39
13	5.13	Decoding of Synthesis Filterbank for 16 KHz decoding for SO 70.....	5-40
14	5.13.1	Processing the lowband signal, $s_{LB}$ .....	5-40
15	5.13.1.1	Upsample by and lowpass filter.....	5-40
16	5.13.1.2	Shaping Filter.....	5-40
17	5.13.2	Processing the high band signal .....	5-41
18	5.13.2.1	Interpolation to 14 kHz.....	5-41
19	5.13.2.2	Spectral reversal.....	5-41
20	5.13.2.3	Interpolation to 28 kHz.....	5-41
21	5.13.2.4	Resampling to 16 KHz.....	5-41
22	5.13.3	Combining the lowband and highband.....	5-41
23	6	TTY/TDD Extension for SO 3.....	6-1
24	6.1	Introduction.....	6-1
25	6.2	Overview.....	6-1
26	6.3	TTY/TDD Extension.....	6-2
27	6.3.1	TTY Onset Procedure .....	6-2
28	6.3.1.1	Encoder TTY Onset Procedure.....	6-2
29	6.3.1.2	Decoder TTY Onset Procedure.....	6-2
30	6.3.1.3	TTY_MODE PROCESSING .....	6-3
31	6.3.1.4	TTY_SILENCE Processing.....	6-3
32	6.3.2	TTY Header, Baud Rate, and Character Format.....	6-3

1	6.3.3	Transporting the TTY Information in the Speech Packet.....	6-4
2	6.3.3.1	Half Rate TTY Mode.....	6-5
3	6.3.3.2	Interoperability with 45.45 Baud-Only TTY Extensions.....	6-5
4	6.3.3.3	Reflected Baudot Tones.....	6-6
5	6.3.4	TTY/TDD Processing Recommendation.....	6-6
6	6.3.5	TTY Encoder Processing.....	6-7
7	6.3.5.1	TTY Encoder Inputs.....	6-8
8	6.3.5.2	Dit Classification.....	6-8
9	6.3.5.3	Dits to Bits.....	6-8
10	6.3.5.4	TTY Character Classification.....	6-9
11	6.3.5.5	TTY Baud Rate Determination.....	6-9
12	6.3.5.6	TTY State Machine.....	6-9
13	6.3.6	TTY/TDD Decoder Processing.....	6-10
14	6.3.6.1	TTY Decoder Inputs.....	6-10
15	6.3.6.2	Decoding the TTY/TDD Information.....	6-10
16	6.3.6.3	Baudot Generator.....	6-11
17	6.3.6.4	Tone Generator.....	6-12
18	7	EVRC-B Data Capabilities.....	7-1
19	7.1	EVRC-B data capabilities.....	7-1
20	7.2	TTY/TDD payload format.....	7-2
21	7.3	Baudot code payload.....	7-2
22	7.4	DTMF payload format.....	7-4
23	7.5	TTY/TDD operation.....	7-5
24	7.5.1	TTY header and character format.....	7-6
25	7.5.2	TTY encoder processing.....	7-7
26	7.5.2.1	TTY encoder inputs.....	7-7
27	7.5.2.2	Dit classification.....	7-8
28	7.5.2.3	Dits to bits.....	7-8
29	7.5.2.4	TTY character classification.....	7-9
30	7.5.2.5	TTY baud rate determination.....	7-9
31	7.5.2.6	TTY state machine.....	7-10
32	7.5.3	TTY/TDD decoder processing.....	7-10

1	7.5.3.1	TTY decoder inputs .....	7-10
2	7.5.3.2	Decoding the TTY/TDD information .....	7-10
3	7.5.3.3	Baudot generator .....	7-11
4	7.5.3.4	Tone generator .....	7-12
5	7.6	DTMF .....	7-12
6	7.6.1	DTMF detector.....	7-12
7	7.6.1.1	Description of the DTMF detector.....	7-12
8	7.6.1.2	Input.....	7-12
9	7.6.1.3	Output .....	7-13
10	8	Change History for EVRC .....	8-1
11	9	CODEBOOK MEMORIES AND CONSTANTS .....	9-1
12			

## 1 LIST OF FIGURES

2	Figure 4.1-1 Speech Encoder Top-Level Diagram.....	4-2
3	Figure 4.2-1 Speech encoder top-level diagram.....	4-5
4	Figure 4.2-2 Speech decoder top-level diagram.....	4-6
5	Figure 4.2.2.4-1 Continuous range of COPs .....	4-8
6	Figure 4.2.4.1-1 Illustration of the principles of PPP coding.....	4-11
7	Figure 4.2.4.2-1 Block diagram of PPP coding scheme.....	4-12
8	Figure 4.2.4.4-1 A block diagram of amplitude quantization and dequantization modules.....	4-13
9	Figure 4.2.4.4-2 An illustrative non-uniform band partition used PPP quantization .....	4-13
10	Figure 4.2.4.4-3 Illustration of the effect of spectral downsampling and upsampling .....	4-14
11	Figure 4.2.4.5-1 Demonstration of the effect of a single-band alignment on a single PPP.....	4-15
12	Figure 4.2.4.5-2 Demonstration of the effect of multi-band alignments on a single PPP .....	4-16
13	Figure 4.3-1 EVRC-WB Conceptual Overview .....	4-17
14	Figure 4.3-2 Wideband Encoder .....	4-19
15	Figure 4.3-3 Wideband Decoder .....	4-19
16	Figure 4.3.3.2-1 High-band analysis .....	4-21
17	Figure 4.3.3.3-1 Generation of the high-band excitation signal.....	4-22
18	Figure 4.3.5-1 High-band synthesis .....	4-23
19	Figure 4.4.3-1 Noise Suppression Block Diagram.....	4-27
20	Figure 4.5-1 Analysis Filter Bank .....	4-36
21	Figure 4.8.1-1 Pitch-based NACF computation.....	4-58
22	Figure 4.8.3.1-1 High level diagram of mode decision.....	4-62
23	Figure 4.8.3.1-2 $nacf\_at\_pitch[2] > VOICEDTH$ – second subframe NACF of the current frame is high .....	4-62
24	Figure 4.8.3.1-3 $nacf\_at\_pitch[2] < UNVOICEDTH$ – second subframe NACF of the current frame is low..	4-64
25	Figure 4.8.3.1-4 $nacf\_at\_pitch[2] \geq UNVOICEDTH \ \&\& \ nacf\_at\_pitch[2] \leq VOICEDTH$ .....	4-67
26	Figure 4.11-1 RCELP Encoding Block Diagram.....	4-82
27	Figure 4.13-1 Rate 1 Generic Audio Encoding Block Diagram.....	4-146
28	Figure 4.14-1 Excitation coding for Rate $\frac{1}{4}$ unvoiced frames for SO 68 and Rate $\frac{1}{2}$ unvoiced frames for SO 70	
29	WB .....	4-152
30	Figure 4.18.1-1 Pre-processing of the high band to remove clicks .....	4-163
31	Figure 4.18.1-2 Energy burst detector.....	4-164
32	Figure 4.18.3-1 Generation of the high-band excitation signal.....	4-165

1	Figure 5-1 SO 3 Speech Decoder Top-Level Diagram .....	5-1
2	Figure 5.4-1 Rate 1 Generic Audio Decoding Block Diagram .....	5-20
3	Figure 5.5-1 Excitation decoding for rate 1/4 NELP or rate 1/2 special NELP .....	5-21
4	Figure 5.7-1 Comfort Noise Synthesizer Block Diagram .....	5-26
5	Figure 5.10-1 Background Noise Estimator Block Diagram .....	5-34
6	Figure 5.11-1 Background Noise Estimator Block Diagram .....	5-37
7	Figure 5.13-1 Synthesis Filterbank for SO 70 16 KHz Decoding.....	5-40
8	Figure 6.3.4-1 TTY/TDD Processing Block Diagram .....	6-7
9	Figure 7.5-1 TTY/TDD processing block diagram .....	7-6
10		

1  
2  
3  
4  
5  
6  
7  
8  
9  
10  
11  
12  
13  
14  
15  
16  
17  
18  
19  
20  
21  
22  
23  
24  
25  
26  
27  
28  
29  
30  
31  
32

## LIST OF TABLES

Table 2.1.1-1 Packet Types Supplied by Service Options 3, 68, and 70 to the Multiplex Sublayer .....	2-1
Table 2.1.2-1 Packet Types Supplied by the Multiplex Sublayer to Service Options 3, and 68 .....	2-2
Table 2.2.1.2-1 Fraction of Packets at Rate 1 and Rate 1/2 with Rate Reduction .....	2-4
Table 2.2.1.2-2 Sequence Parameters for Rate Reduction .....	2-5
Table 2.2.2-1 Valid Service Configuration Attributes for Service Option 3 .....	2-5
Table 2.2.2.2.1-1 Sequence Parameters for Rate Reduction .....	2-7
Table 2.2.2.2.2-1 Service Option Control Message Type-Specific Fields .....	2-8
Table 2.2.2.2.2-2 Fraction of Packets at Rate 1 and Rate 1/2 with Rate Reduction .....	2-9
Table 2.3-1 Service Option Group Assignments .....	2-9
Table 2.4.1-1 Valid service configuration attributes for Service Option 68 .....	2-10
Table 2.4.1.2-1 Service Option 68 Encoding rate control parameters .....	2-12
Table 2.4.1.2-2 Service Option Control message type-specific fields .....	2-12
Table 2.4.1.2-3 Service Option Control message type-specific fields .....	2-13
Table 2.4.1.2-4 Service Option 68 encoding rate control parameters .....	2-14
Table 2.5.1-1 Valid service configuration attributes for Service Option 70 .....	2-15
Table 2.5.1.2-1 Service Option 70 Encoding rate control parameters .....	2-17
Table 2.5.1.2-2 Service Option Control message type-specific fields .....	2-18
Table 2.5.1.2-3 Service Option Control message type-specific fields .....	2-18
Table 2.5.1.2-4 Service Option 70 encoding rate control parameters .....	2-19
Table 4.1-1 Bit Allocations by Packet Type .....	4-1
Table 4.2-1 EVRC-B coding schemes .....	4-3
Table 4.2-2 Bit allocations by packet type .....	4-4
Table 4.3.2-1 Bit allocation .....	4-20
Table 4.6.2.1-1 LSP Interpolation Constants .....	4-43
Table 4.7.1.1-1 FIR Filter Coefficients Used for Band Energy Calculations .....	4-51
Table 4.7.1.2.1-1 Threshold Scale Factors as a Function of SNR .....	4-52
Table 4.7.1.2.2-1 Threshold scale factors as a function of SNR .....	4-52
Table 4.7.1.2.2-2 Threshold scale factors as a function of SNR .....	4-53
Table 4.7.1.2.2-3 Threshold scale factors as a function of SNR .....	4-53
Table 4.7.1.4.1-1 Hangover Frames as a Function of SNR .....	4-54

1	Table 4.7.1.4.2-1 Hangover Frames as a Function of SNR.....	4-54
2	Table 4.7.1.4.2-2 Hangover Frames as a Function of SNR.....	4-55
3	Table 4.7.1.4.2-3 Hangover Frames as a Function of SNR.....	4-55
4	Table 4.8.3.1-1 Features used in mode decision .....	4-61
5	Table 4.8.4-1 Mapping of speech mode decision to encoding rate and mode.....	4-71
6	Table 4.9-1 LSP Parameter Splits .....	4-72
7	Table 4.9-2 Number of LSP Codebooks .....	4-73
8	Table 4.10.2-1 LSPVQ parameters for full- rate and SO 70 unvoiced half-rate .....	4-76
9	Table 4.10.2-2 Multiple candidate search in full-rate and SO 70 unvoiced half-rate LSPVQ.....	4-76
10	Table 4.10.3-1 LSPVQ parameters for half-rate .....	4-77
11	Table 4.10.3-2 Multiple candidate search in half-rate LSPVQ .....	4-77
12	Table 4.10.4-1 LSPVQ parameters for quarter-rate unvoiced.....	4-78
13	Table 4.10.7-1 LSPVQ parameters for eighth rate SO 70 WB mode .....	4-80
14	Table 4.11.4.9-1 Adaptive Codebook Gain Quantization Table .....	4-87
15	Table 4.11.7.1-1 Positions of Individual Pulses in the Rate 1 Algebraic Codebook.....	4-102
16	Table 4.11.7.2.2-1 Codeword for the Track Orders .....	4-105
17	Table 4.11.7.4-1 Positions of Individual Pulses in the Rate 1/2 Algebraic Codebook.....	4-107
18	Table 4.11.8.1-1 Number of Pulses generated by Factorial Codebooks .....	4-109
19	Table 4.11.8.3-1 Definitions for full-rate CELP factorial codebook.....	4-113
20	Table 4.11.8.3-2 Dynamic Bit Allocation of Excitation Indices .....	4-114
21	Table 4.11.8.5-1 Pulse positions for half-rate CELP codebook .....	4-117
22	Table 4.11.8.5-2 Skew table for half-rate CELP codebook .....	4-118
23	Table 4.11.8.5-3 Pulse positions for half-rate CELP codebook.....	4-118
24	Table 4.19-1 Packet Formats.....	4-167
25	Table 4.20-1 Packet formatting for Full-rate CELP.....	4-170
26	Table 4.20-2 Packet formatting for Full-rate PPP .....	4-171
27	Table 4.20-3 Packet formatting for Half-rate CELP .....	4-172
28	Table 4.20-4 Packet formatting for Special Half-rate CELP.....	4-172
29	Table 4.20-5 Packet formatting for Special Half-rate PPP.....	4-173
30	Table 4.20-6 Packet formatting for Special Half-rate NELP .....	4-174
31	Table 4.20-7 Packet formatting for Quarter-rate NELP .....	4-174
32	Table 4.20-8 Packet formatting for Quarter-rate PPP .....	4-174

1	Table 4.20-9 Packet formatting for Eighth-Rate .....	4-175
2	Table 4.21-1 Packet formatting for Full-rate CELP in SO 68 Interoperable Mode .....	4-176
3	Table 4.21-2 Packet formatting for Full-rate Wideband CELP Frame .....	4-177
4	Table 4.21-3 Packet formatting for Full-rate Wideband MDCT Frame.....	4-177
5	Table 4.21-4 Packet formatting for Full-rate Narrowband MDCT Frame .....	4-178
6	Table 4.21-5 Packet formatting for Half-rate Wideband NELP Frame.....	4-178
7	Table 4.21-6 Packet formatting for Half-rate CELP in SO 68 Interoperable Mode.....	4-178
8	Table 4.21-7 Packet formatting for Eighth-Rate in SO 68 Interoperable Mode .....	4-179
9	Table 4.21-8 Packet formatting for Eighth-Rate in Wideband Mode .....	4-179
10	Table 4.21-9 Packet formatting for Special Half-rate Wideband CELP Frame (for packet level signaling) .	4-179
11	Table 4.21-10 Packet formatting for Special Half-rate CELP in SO 68 interoperable mode.....	4-180
12	Table 5.1.1-1 Received Packet Type Decoding .....	5-2
13	Table 5.1.2-1 Received Packet Type Decoding .....	5-3
14	Table 5.8.1-1 Postfilter Coefficients .....	5-29
15	Table 6.3.2-1 TTY Header and Character Fields .....	6-4
16	Table 6.3.3-1 TTY Header and Character Bit Assignment .....	6-5
17	Table 6.3.3.2-1 Baud Rate Interoperability Matrix .....	6-6
18	Table 6.3.5.3-1 TTY Bit History Buffer.....	6-9
19	Table 6.3.6.2-1 tty_dec() History Buffer.....	6-10
20	Table 7.1-1 Bit allocation for rate 1/2 data frames.....	7-1
21	Table 7.1-2 Illegal codeword value.....	7-2
22	Table 7.1-3 Data header description.....	7-2
23	Table 7.2-1 TTY Type field .....	7-2
24	Table 7.3-1 Rate 1/2 packet for TTY/TDD baudot code payload.....	7-3
25	Table 7.4-1 Rate 1/2 packet with DTMF payload.....	7-4
26	Table 7.4-2 DTMF data values.....	7-4
27	Table 7.5.1-1 Range of values for TTY/TDD Baudot header field.....	7-7
28	Table 7.5.1-2 Range of values for TTY/TDD Baudot character field.....	7-7
29	Table 7.5.1-3 Range of values for TTY/TDD baud rate field .....	7-7
30	Table 7.5.2.3-1 TTY bit history buffer.....	7-9
31	Table 7.5.3.2-1 tty_dec() history buffer .....	7-10
32	Table 7.6.1-1 Touch-tone telephone keypad.....	7-12

1	Table 9-1 LSP Quantization Table, Rate 1, Codebook 1 .....	9-1
2	Table 9-2 LSP Quantization Table, Rate 1, Codebook 2 .....	9-1
3	Table 9-3 LSP Quantization Table, Rate 1, Codebook 3 .....	9-2
4	Table 9-4 LSP Quantization Table, Rate 1, Codebook 4 .....	9-7
5	Table 9-5 LSP Quantization Table, Rate 1/2, Codebook 1 .....	9-9
6	Table 9-6 LSP Quantization Table, Rate 1/2, Codebook 2 .....	9-10
7	Table 9-7 LSP Quantization Table, Rate 1/2, Codebook 3 .....	9-11
8	Table 9-8 LSP Quantization Table, Rate 1/8, Codebook 1 .....	9-17
9	Table 9-9 LSP Quantization Table, Rate 1/8, Codebook 2 .....	9-17
10	Table 9-10 Interpolation Filter Coefficients, Cutoff=0.5 (1/2) .....	9-18
11	Table 9-11 Interpolation Filter Coefficients, Cutoff=0.5 (2/2) .....	9-18
12	Table 9-12 Interpolation Filter Coefficients, Cutoff=0.9 (1/3) .....	9-18
13	Table 9-13 Interpolation Filter Coefficients, Cutoff=0.9 (2/3) .....	9-18
14	Table 9-14 Interpolation Filter Coefficients, Cutoff=0.9 (3/3) .....	9-19
15	Table 9-15 Fixed Codebook Gain Quantization, Rate 1 .....	9-19
16	Table 9-16 Fixed Codebook Gain Quantization, Rate 1/2 .....	9-19
17	Table 9-17 Residual Shift Interpolation Filter Coefficients .....	9-20
18	Table 9-18 Rate 1/8 Frame Energy Quantization .....	9-20

19  
20

## 1 GENERAL

### 1.1 General Description

Service Options 3, 68, and 70 provide two-way voice communications between the base station and the mobile station using the dynamically variable data rate speech codec algorithm described in this standard. The transmitting speech codec takes voice samples and generates an encoded speech packet for every Traffic Channel frame.<sup>†</sup> The receiving station generates a speech packet from every Traffic Channel frame and supplies it to the speech codec for decoding into voice samples.

Speech codecs communicate at one of four rates corresponding to the 9600 bps, 4800 bps, 2400, and 1200 bps frame rates. However, Service Option 3 does not use 2400 bps frame rate.

The specifications defined in Sections 4 and 5 of this document provide the detailed algorithmic description of the EVRC. In the case of a discrepancy between the floating point and algorithmic descriptions, the reference floating point c-code will prevail. The specifications defined in Input Signal Preprocessing (see 4.4), Determining the Data Rate (see 4.7), and Adaptive Postfilter (see 5.8 and 5.9) are optional for implementations intended for varying operational environments (such as in-vehicle hands-free). Any implementations which deviate from the algorithms specified in this standard, shall meet the minimum performance requirements defined in the associated Minimum Performance Specifications.

### 1.2 Service Option Number

The variable data rate two-way voice service option using the speech codec algorithm described by this standard shall use service option numbers 3, 68, and 70 and shall be called Service Options 3, 68, and 70 respectively.

### 1.3 Allowable Delays

#### 1.3.1 Allowable Transmitting Speech Codec Encoding Delay

The transmitting speech codec shall supply a packet to the multiplex sublayer no later than 20 ms after it has obtained the last input sample for the current speech frame.

#### 1.3.2 Allowable Receiving Speech Codec Decoding Delay

The receiving decoder shall generate the first sample of speech using parameters from a packet supplied to it by the multiplex sublayer not later than 3 ms after being supplied the packet.

---

<sup>†</sup> Common speech codec terminology also uses the term frame to represent a quantum of processing. For Service Options 3, 68, and 70, the speech codec frame corresponds to speech sampled over 20 ms. The speech samples are processed into a packet. This packet is transmitted in a Traffic Channel frame.

1 **1.4 Special Cases**

2 1.4.1 Blanked Packets

3 A blanked frame occurs when the transmitting station uses the entire frame for either signaling traffic or  
4 secondary traffic. The EVRC does no special encode processing during the generation of a blank packet, i.e.,  
5 the generated voice packet is simply not used. The decoder, in turn, treats a blank packet in the same manner as  
6 a frame erasure.

7 1.4.2 Null Traffic Channel Data

8 A Rate 1/8 packet with all bits set to '1' is considered as null Traffic Channel data. This packet is declared an  
9 erased packet and handled as described in Section 5. If more than 2 consecutive all-ones Rate 1/8 packets are  
10 received, the decoder's output shall be muted until a valid packet is received.

11 1.4.3 All Zeros Packet

12 Rate 1 and Rate 1/2 packets with all bits set to '0' shall be considered erased frames and shall be handled as  
13 described in Section 5.

14 **1.5 Terms and Numeric Information**

15 **ACB.** Adaptive Codebook.

16 **ACELP.** Algebraic Code Excited Linear Predictive Coding, the algorithm that is used by the EVRC to  
17 generate the stochastic component of the excitation.

18 **Autocorrelation Function.** A function showing the relationship of a signal with a time-shifted version of  
19 itself.

20 **Base Station.** A station in the Domestic Public Radio Telecommunications Service, other than a mobile  
21 station, used for radio communications with mobile stations.

22 **CCITT.** New revisions of CCITT standards will have an ITU designation.

23 **CELP.** See Code Excited Linear Predictive Coding.

24 **Codec.** The combination of an encoder and decoder in series (encoder/decoder).

25 **Code Excited Linear Predictive Coding (CELP).** A speech coding algorithm. CELP codecs use codebook  
26 excitation, a long-term pitch prediction filter, and a short-term formant prediction filter.

27 **Codebook.** A set of vectors used by the speech codec in Service Option 3. For each speech codec codebook  
28 subframe, one particular vector is chosen and used to excite the speech codec's filters. The codebook vector is  
29 chosen to minimize the weighted error between the original and synthesized speech after the pitch and formant  
30 synthesis filter coefficients have been determined.

31 **Decoder.** Generally, a device for the translation of a signal from a digital representation into an analog format.  
32 For this standard, a device which converts speech encoded in the format specified in this standard to analog or  
33 an equivalent PCM representation.

34 **DFS.** Discrete Fourier Series

35 **DFT.** See Discrete Fourier Transform.

36 **Discrete Fourier Transform (DFT).** A method of transforming a time domain sequence into a corresponding  
37 frequency domain sequence.

- 1 **Encoder.** Generally, a device for the translation of a signal into a digital representation. For this standard, a  
2 device which converts speech from an analog or its equivalent PCM representation to the digital representation  
3 described in this standard.
- 4 **EVRC.** Enhanced Variable Rate Codec.
- 5 **FCB.** Fixed Codebook.
- 6 **FFT.** See Fast Fourier Transform.
- 7 **Fast Fourier Transform (FFT).** An efficient implementation of the Discrete Fourier Transform.
- 8 **Formant.** A resonant frequency of the human vocal tract causing a peak in the short-term spectrum of speech.
- 9 **IDFT.** See Inverse Discrete Fourier Transform.
- 10 **IIR Filter.** An infinite-duration impulse response filter is a filter for which the output, in response to an  
11 impulse input, never totally dies away. This term is usually used in reference to digital filters.
- 12 **Interpolation.** In the speech coder context, a means of smoothing the transitions of estimated parameters from  
13 one set to another. Usually a linear function.
- 14 **Inverse Discrete Fourier Transform (IDFT).** A method of transforming a frequency domain sequence into a  
15 corresponding time domain sequence.
- 16 **ITU.** International Telecommunication Union.
- 17 **Linear Predictive Coding (LPC).** A method of predicting future samples of a sequence by a linear  
18 combination of the previous samples of the same sequence. Linear Predictive Coding is frequently used in  
19 reference to a class of speech codecs.
- 20 **Line Spectral Pair (LSP).** A representation of digital filter coefficients in a pseudo-frequency domain. This  
21 representation has good quantization and interpolation properties.
- 22 **LPC.** See Linear Predictive Coding.
- 23 **LSB.** Least significant bit.
- 24 **LSP.** See Line Spectral Pair.
- 25 **Mobile Station.** A station in the Domestic Public Radio Telecommunications Service intended to be used  
26 while in motion or during halts at unspecified points. It is assumed that mobile stations include portable units  
27 (e.g., hand-held personal units) and units installed in vehicles
- 28 **MSB.** Most significant bit.
- 29 **Packet.** The unit of information exchanged between service option applications in the base station and the  
30 mobile station.
- 31 **Pitch.** The fundamental frequency in speech caused by the periodic vibration of the human vocal cords.
- 32 **PPP.** Prototype Pitch Period
- 33 **PSTN.** Public Switched Telephone Network.
- 34 **Quantization.** A process that allows one or more data elements to be represented at a lower resolution for the  
35 purpose of reducing the effective bandwidth required for transmission or storage of the respective data  
36 elements.
- 37 **RCELP.** Relaxed Code Excited Linear Predictive Coding, the speech coding algorithm on which the EVRC is  
38 based.

1 **Receive Objective Loudness Rating (ROLR).** A measure of receive audio sensitivity. ROLR is a frequency-  
2 weighted ratio of the line voltage input signal to a reference encoder to the acoustic output of the receiver.  
3 IEEE 269-2002 [S4] defines the measurement of sensitivity and IEEE 661-1979 [S5] defines the calculation of  
4 objective loudness rating.

5 **ROLR.** See Receive Objective Loudness Rating.

6 **TOLR.** See Transmit Objective Loudness Rating.

7 **Transmit Objective Loudness Rating (TOLR).** A measure of transmit audio sensitivity. TOLR is a  
8 frequency-weighted ratio of the acoustic input signal at the transmitter to the line voltage output of the  
9 reference decoder. IEEE 269-2002 [S4] defines the measurement of sensitivity and IEEE 661-1979 [S5]  
10 defines the calculation of objective loudness rating.

11 **WAEPL.** Weighted Acoustic Echo Path Loss. A measure of the echo performance under normal  
12 conversation. ANSI/EIA/TIA-579-A-98 [S1] defines the measurement of WAEPL.

13 **Zero Input Response (ZIR).** The filter output caused by the non-zero initial state of the filter when no input is  
14 present.

15 **Zero State Response (ZSR).** The filter output caused by an input when the initial state of the filter is zero.

16 **ZIR.** See Zero Input Response.

17 **ZSR.** See Zero State Response.

## 2 REQUIRED MULTIPLEX OPTION SUPPORT

Service Options 3, 68, and 70 shall support an interface with Multiplex Option 1. Speech packets for Service Options 3, 68, and 70 shall only be transported as primary traffic. This Specification is consistent with the context of TIA/EIA/IS-95 [N3] and TIA-95 [N4], and is also pertinent to appropriate provisions of more recent applicable Specifications (e.g. [N5]).

### 2.1 Interface to Multiplex Option 1

#### 2.1.1 Transmitted Packets

The speech codec shall generate and supply exactly one packet to the multiplex sublayer every 20 milliseconds. The packet contains the service option information bits, which are transmitted as primary traffic. The packet shall be one of four types as shown in Table 2.1.1-1. The number of bits supplied to the multiplex sublayer for each type of packet shall also be as shown in Table 2.1.1-1. Unless otherwise commanded, the speech codec may supply a Rate 1, Rate 1/2, Rate 1/4 or Rate 1/8 packet. Upon command, the speech codec shall generate a Blank packet. Also upon command, the speech codec shall generate a non-blank packet with a maximum rate of Rate 1/2.

A Blank packet contains no bits and is used for blank-and-burst transmission of signaling traffic or secondary traffic (see [N4]).

**Table 2.1.1-1 Packet Types Supplied by Service Options 3, 68, and 70 to the Multiplex Sublayer**

Packet Type	Bits per Packet
Rate 1	171
Rate 1/2	80
Rate 1/4	40
Rate 1/8	16
Blank	0

#### 2.1.2 Received Packets

The multiplex sublayer in the receiving station categorizes every received Traffic Channel frame, and supplies the packet type and accompanying bits, if any, to the speech codec as shown in Table 2.1.1-1. The speech codec processes the bits of the packet as described in Section 4. The received packet types shown in Table 2.1.2-1 correspond to the transmitted packet types shown in Table 2.1.1-1. The Blank packet type occurs when the receiving station determines that a blank-and-burst frame for signaling traffic or secondary traffic was transmitted. The Rate 1 with bit errors packet type occurs when the receiving station determines that the frame was transmitted at 9600 bps and the frame has one or more bit errors. The insufficient frame quality packet type occurs when the mobile station is unable to decide upon the data rate of the received frame or when the mobile station detects a frame in error, which does not belong to the Rate 1 with bit errors packet type. Although the Service Option 3 does not utilize Rate 1/4 packets, Multiplex Option 1 is not required to

1 recognize this fact; Service Option 3 is, therefore, responsible for declaring Rate 1/4 frames as having  
 2 insufficient frame quality (erasure). Service Option 68 utilizes Rate 1/4 packets.

3  
 4 **Table 2.1.2-1 Packet Types Supplied by the Multiplex Sublayer to Service Options 3, and 68**

Packet Type	Bits per Packet
Rate 1	171
Rate 1/2	80
Rate 1/4	40
Rate 1/8	16
Blank	0
Rate 1 with bit errors	171
Insufficient frame quality (erasure)	0

5  
 6 **2.2 Negotiation for Service Option 3**

7 The mobile station and base station can negotiate for Service Option 3 using either service option negotiation,  
 8 as described in [N4], or service negotiation, as described in [N3] and ANSI J-STD-008.

9 **2.2.1 Procedures Using Service Option Negotiation**

10 The mobile station shall perform service option negotiation for Service Option 3 as described in [N4]. The base  
 11 station shall perform service option negotiation for Service Option 3 as described in [N4].

12 **2.2.1.1 Initialization and Connection**

13 **2.2.1.1.1 Initialization and Connection in the Mobile Station**

14 If the mobile station sends a *Service Option Response Order* accepting Service Option 3 in response to  
 15 receiving a *Service Option Request Order*, (see [N4]), the mobile station shall initialize and connect Service  
 16 Option 3 according to the following:

- 17 • If the mobile station is in the *Conversation Substate*, the mobile station shall complete the initialization  
 18 and connection of the transmitting and receiving sides within 200 ms of:
  - 19 • The implicit or explicit action time associated with the *Service Option Request Order* (see [N4]),  
 20 or
  - 21 • The time that the mobile station sends the *Service Option Response Order* accepting Service  
 22 Option 3,

23 whichever is later.

- 24 • If the mobile station is not in the *Conversation Substate*, the mobile station shall complete the  
 25 initialization and connection of the transmitting side within 200 ms of:
  - 26 • The implicit or explicit action time associated with the *Service Option Request Order*,

- 1           • The time that the mobile station sends the *Service Option Response Order* accepting Service
- 2           Option 3, or
- 3           • The time that the mobile station enters the *Conversation Substate*, whichever is later.
- 4           • If the mobile station is not in the *Conversation Substate*, the mobile station shall complete the
- 5           initialization and connection of the receiving side within 200 ms of:
  - 6           • The implicit or explicit action time associated with the *Service Option Request Order*,
  - 7           • The time that the mobile station sends the *Service Option Response Order* accepting Service
  - 8           Option 3, or
  - 9           • If not in the *Conversation Substate*, the time that the mobile station enters the *Waiting for Answer*
  - 10          *Substate e*, whichever is later.

11 If the mobile station receives a *Service Option Response Order* accepting its request for Service Option 3 (see  
12 [N4]), the mobile station shall initialize and connect Service Option 3 according to the following:

- 13           • If the mobile station is in the *Conversation Substate e*, the mobile station shall complete the
- 14           initialization and connection of the transmitting and receiving sides within 200 ms of:
  - 15           • The implicit or explicit action time associated with the *Service Option Response Order* (see [N4]).
- 16           • If the mobile station is not in the *Conversation Substate*, the mobile station shall complete the
- 17           initialization and connection of the transmitting side within 200 ms of:
  - 18           • The implicit or explicit action time associated with the *Service Option Response Order*, or
  - 19           • The time that the mobile station enters the *Conversation Substate*, whichever is later.
- 20           • If the mobile station is not in the *Conversation Substate*, the mobile station shall complete the
- 21           initialization and connection of the receiving side within 200 ms of:
  - 22           • The implicit or explicit action time associated with the *Service Option Response Order*, or
  - 23           • The time that the mobile station enters the *Waiting for Answer Substate*, whichever is later.

24 Service Option 3 initializations are described in Sections 4 and 5.

25 When the transmitting side of Service Option 3 is connected, Service Option 3 shall generate and transfer  
26 packets to the multiplex sublayer. When the receiving side is connected, Service Option 3 shall transfer and  
27 process packets from the multiplex sublayer. Refer to [N4] when the transmitting side of a service option is not  
28 connected.

#### 29 2.2.1.1.2 Initialization and Connection in the Base Station

30 The base station should wait until the action time associated with the most recently transmitted *Service Option*  
31 *Response Order* or *Service Option Request Order* before initializing and connecting Service Option 3.

32 If the base station accepts Service Option 3 (by sending a *Service Option Response Order* as described in [N4],  
33 it should initialize and connect both the transmitting and receiving side of Service Option 3 before the called  
34 party is connected, so that both the base station and mobile station speech codecs can stabilize. The base  
35 station may defer connecting the land party audio to the speech codec.

36 If the base station receives an acceptance of its request for Service Option 3 (by receiving a *Service Option*  
37 *Response Order* as described in [N4], it should initialize and connect both the transmitting and receiving side of  
38 Service Option 3 before the called party is connected so that both the base station and mobile station speech  
39 codecs can stabilize. The base station may defer connecting the land party audio to the speech codec.

1 When the transmitting side of Service Option 3 is connected, Service Option 3 shall generate and transfer  
 2 packets to the multiplex sublayer. When the receiving side is connected, Service Option 3 shall transfer and  
 3 process packets from the multiplex sublayer. Refer to [N4] when the transmitting side of a service option is not  
 4 connected.

5 2.2.1.2 Service Option Control Orders

6 The base station may send a *Service Option Control Order* to the mobile station on the Forward Traffic  
 7 Channel (see [N3]). In addition to pending ACTION\_TIMEs for messages or orders not related to the *Service*  
 8 *Option Control Order* for Service Option 3, the mobile station shall support at least one pending  
 9 ACTION\_TIME for *Service Option Control Orders* for Service Option 3. The mobile station shall not send a  
 10 *Service Option Control Order* for this service option.

11 If Service Option 3 is active, the mobile station shall treat the ORDQ field in the *Service Option Control Order*  
 12 as follows:

13 If ORDQ equals ‘xxx000x1’, then the mobile station shall initialize both the transmitting and receiving sides of  
 14 the speech codec as described in Section 4 and 5. The initializations shall begin at the implicit or explicit action  
 15 time (see [N4]) and shall be completed within 40 ms. In addition, if ORDQ equals ‘xxx00011’ then the mobile  
 16 station should disable the audio output of the speech codec for 1 second after initialization.

17 If Service Option 3 is active and the mobile station receives a *Service Option Control Order* having an ORDQ  
 18 field in which the 3 MSBs have values given in Table 2.2.1.2-1, then the mobile station shall generate the  
 19 fraction of those packets normally generated as Rate 1 packets (see 4.3) at either Rate 1 or Rate 1/2 as specified  
 20 by the corresponding line in the table. The mobile station shall continue to use these fractions until either of the  
 21 following events occurs:

- 22 • While Service Option 3 is active, the mobile station receives a *Service Option Control Order* that
- 23 specifies different fractions, or
- 24 • Service Option 3 is initialized.

25

26

**Table 2.2.1.2-1 Fraction of Packets at Rate 1 and Rate 1/2 with Rate Reduction**

ORDQ (binary)	Fraction of Normally Rate 1 Packets to be Rate 1	Fraction of Normally Rate 1 Packets to be Rate 1/2
000XXXXX	1	0
001XXXXX	3/4	1/4
010XXXXX	1/2	1/2
011XXXXX	1/4	3/4
100XXXXX	0	1

27

28 The mobile station may use the following procedure to perform this rate reduction: Sequences of *N* packets as  
 29 are formed as shown in Table 2.2.1.2-2. The first *L* packets in this sequence are allowed to be at Rate 1, the  
 30 next *N-L* packets are forced to be Rate 1/2. Whenever the rate determination process (see 4.3) selects a rate

1 other than Rate 1, the sequence is reset. This ensures that the first packet in a talk spurt will be at Rate 1, unless  
 2 ORDQ equals '100XXXXX' or the speech codec has been commanded by the multiplex sublayer to generate  
 3 other than a Rate 1 packet (see 2.1.1).

4  
 5 **Table 2.2.1.2-2 Sequence Parameters for Rate Reduction**

ORDQ (binary)	Sequence Length, N	Maximum Number of Contiguous Rate 1 Packets in a Sequence, L	Number of Contiguous Rate 1/2 Packets in a Sequence, N-L
000XXXXX	1	1	0
001XXXXX	4	3	1
010XXXXX	2	1	1
011XXXXX	4	1	3
100XXXXX	1	0	1

6  
 7 Any other *Service Option Control Order* referring to Service Option 3 and having an ORDQ field other than  
 8 those described in this section shall be rejected using the *Mobile Station Reject Order* with an ORDQ field  
 9 equal to '00000100' (see [N4]).

#### 10 2.2.2 Procedures Using Service Negotiation

11 The mobile station and base station shall perform service negotiation for Service Option 3 as described in [N3]  
 12 or J-STD-008, and the negotiated service configuration shall include only valid attributes for the service option  
 13 as specified in Table 2.2.2-1.

14  
 15 **Table 2.2.2-1 Valid Service Configuration Attributes for Service Option 3**

Service Configuration Attribute	Valid Selections
Forward Multiplex Option	Multiplex Option 1
Reverse Multiplex Option	Multiplex Option 1
Forward Transmission Rates	Rate Set 1 with all rates enabled
Reverse Transmission Rates	Rate Set 1 with all rates enabled
Forward Traffic Type	Primary Traffic
Reverse Traffic Type	Primary Traffic

16

1 2.2.2.1 Initialization and Connection

2 2.2.2.1.1 Mobile Station Requirements

3 If the mobile station accepts a service configuration, as specified in a *Service Connect Message*, that includes a  
4 service option connection using Service Option 3, the mobile station shall perform the following:

- 5 • If the service option connection is new (that is, not part of the previous service configuration), the  
6 mobile station shall perform speech codec initialization (see Sections 4 and 5) at the action time  
7 associated with the *Service Connect Message*. The mobile station shall complete the initialization  
8 within 40 ms.
- 9 • Commencing at the action time associated with the *Service Connect Message* and continuing for as long  
10 as the service configuration includes the service option connection, Service Option 3 shall process  
11 received packets and generate and supply packets for transmission as follows:
  - 12 • If the mobile station is in the *Conversation Substate*, Service Option 3 shall process the received  
13 packets and generate and supply packets for transmission in accordance with this standard.
  - 14 • If the mobile station is not in the *Conversation Substate*, Service Option 3 shall process the  
15 received packets in accordance with this standard, and shall generate and supply Rate 1/8 Packets  
16 with all bits set to '1' for transmission, except when commanded to generate a Blank packet.

17 2.2.2.1.2 Base Station Requirements

18 If the base station establishes a service configuration, as specified in a *Service Connect Message*, that includes a  
19 service option connection using Service Option 3, the base station shall perform the following:

- 20 • If the service option connection is new (that is, not part of the previous service configuration), the base  
21 station shall perform speech codec initialization (see Sections 4 and 5) no later than the action time  
22 associated with the *Service Connect Message*.
- 23 • Commencing at the action time associated with the *Service Connect Message* and continuing for as long  
24 as the service configuration includes the service option connection, Service Option 3 shall process  
25 received packets and generate and supply packets for transmission in accordance with this standard.  
26 The base station may defer enabling the audio input and output.

27 2.2.2.2 Service Option Control Messages

28 2.2.2.2.1 Mobile Station Requirements

29 The mobile station shall support one pending *Service Option Control Message* for Service Option 3.

30 If the mobile station receives a *Service Option Control Message* for Service Option 3, then, at the action time  
31 associated with the message, the mobile station shall process the message as follows:

- 32 1. If the MOBILE\_TO\_MOBILE field is equal to '1', the mobile station should disable the audio output  
33 of the speech codec for 1 second after initialization.  
34 If the MOBILE\_TO\_MOBILE field is equal to '0', the mobile station shall process each received  
35 packet as described in Section 5.
- 36 2. If the INIT\_CODEC field is equal to '1', the mobile station shall perform speech codec initialization  
37 (see Sections 4 and 5). The mobile station shall complete the initialization within 40 ms.

3. If the RATE\_REDUCE field is equal to a value defined in Table 2.2.2.2.2-2, Service Option 3 shall generate the fraction of those packets normally generated as Rate 1 packets (see 4.3) at either Rate 1 or Rate 1/2 as specified by the corresponding line in Table 2.2.2.2.2-2. Service Option 3 shall continue to use these fractions until either of the following events occur:

- The mobile station receives a *Service Option Control Message* specifying a different RATE\_REDUCE, or
- Service Option 3 is initialized.

Service Option 3 may use the following procedure to perform this rate reduction: Sequences of  $N$  packets as are formed as shown in Table 2.2.2.2.1-1. The first  $L$  packets in this sequence are allowed to be at Rate 1, the next  $N-L$  packets are forced to be Rate 1/2. Whenever the rate determination process (see 4.3) selects a rate other than Rate 1, the sequence is reset. This ensures that the first packet in a talk spurt will be at Rate 1, unless RATE\_REDUCE equals '100' or the speech codec has been commanded by the multiplex sublayer to generate other than a Rate 1 packet (see 2.1.1).

**Table 2.2.2.2.1-1 Sequence Parameters for Rate Reduction**

<b>RATE_REDUCE (binary)</b>	<b>Sequence Length, N</b>	<b>Maximum Number of Contiguous Rate 1 Packets in a Sequence, L</b>	<b>Number of Contiguous Rate 1/2 Packets in a Sequence, N-L</b>
'000'	1	1	0
'001'	4	3	1
'010'	2	1	1
'011'	4	1	3
'100'	1	0	1

If the RATE\_REDUCE field is not equal to a value defined in Table 2.2.2.2.1-1, the mobile station shall reject the message by sending a *Mobile Station Reject Order* with the ORDQ field set equal to '00000100'.

#### 2.2.2.2.2 Base Station Requirements

The base station may send a *Service Option Control Message* to the mobile station. If the base station sends a *Service Option Control Message*, the base station shall include the following type-specific fields for Service Option 3:

**Table 2.2.2.2-1 Service Option Control Message Type-Specific Fields**

Field	Length (bits)
RATE_REDUCE	3
RESERVED	3
MOBILE_TO_MOBILE	1
INIT_CODEC	1

1  
2  
3  
4  
5  
6  
7  
8  
9  
10  
11  
12  
13  
14  
15  
16  
17  
18  
19  
20

RATE\_REDUCE - Rate reduction.

The base station shall set this field to the RATE\_REDUCE value from Table 2.2.2.2-1 corresponding to the rate reduction that the mobile station is to perform.

RESERVED - Reserved bits.

The base station shall set this field to '000'.

MOBILE\_TO\_MOBILE - Mobile-to-mobile processing.

If the mobile station is to perform mobile-to-mobile processing (see 2.2.2.2.1), the base station shall set this field to '1'. In addition, if the mobile station is to disable the audio output of the speech codec for 1 second after initialization, the base station shall set the INIT\_CODEC field and the MOBILE\_TO\_MOBILE field to '1'. If the mobile station is not to perform mobile-to-mobile processing, the base station shall set the MOBILE\_TO\_MOBILE field to '0'.

INIT\_CODEC - Initialize speech codec.

If the mobile station is to initialize the speech codec (see Sections 4 and 5), the base station shall set this field to '1'. Otherwise, the base station shall set this field to '0'.

1 **Table 2.2.2.2.2-2 Fraction of Packets at Rate 1 and Rate 1/2 with Rate Reduction**

<b>RATE_REDUCE (binary)</b>	<b>Fraction of Normally Rate 1 Packets to be Rate 1</b>	<b>Fraction of Normally Rate 1 Packets to be Rate 1/2</b>
'000'	1	0
'001'	3/4	1/4
'010'	1/2	1/2
'011'	1/4	3/4
'100'	0	1
All other RATE_REDUCE values are reserved.		

2 **2.3 Service Option Group Assignments**

3 3GPP2 C.R1001-E (10/2006) specifies a service option group which is a bit map that identifies a logically  
4 related set of service options. The bit map may contain 4, 8, or 12 bits, depending upon the number of logically  
5 related service options in the group. Each bit in the bit map corresponds to one service option.

6 A mobile station or a base station indicates that it supports a service option in the group by setting the bit  
7 corresponding to the service option to '1'. A mobile station or base station can also indicate that it does not  
8 support a service option by setting the bit to '0'. All reserved bits are set to '0'.

9 Table 2.3-1 shows the service option group for SO68. The most significant bit of the service option group map  
10 is on the left, and the least significant bit is on the right.

11  
12 **Table 2.3-1 Service Option Group Assignments**

<b>Service Option Group (Decimal)</b>	<b>Type of Services in the Group</b>	<b>Service Option Group Bit Map and Associated Service Option Assignments</b>
0	Voice Services	--- x ---- SO 68

13 **2.4 Negotiation for Service Option 68**

14 The MS and base station can negotiate for Service Option 68 service negotiation, as described in [N1].

15 **2.4.1 Procedures using service negotiation**

16 The MS and base station shall perform service negotiation for Service Option 68 as described in [N1], and the  
17 negotiated service configuration shall include only valid attributes for the service option as specified in Table  
18 2.4.1-1.

Table 2.4.1-1 Valid service configuration attributes for Service Option 68

Service Configuration Attribute	Valid Selections
Forward Multiplex Option	Multiplex Option 1
Reverse Multiplex Option	Multiplex Option 1
Forward Transmission Rates	Rate Set 1 with all rates enabled
Reverse Transmission Rates	Rate Set 1 with all rates enabled
Forward Traffic Type	Primary Traffic
Reverse Traffic Type	Primary Traffic

#### 2.4.1.1 Initialization and connection

### MS requirements

If the MS accepts a service configuration, as specified in a Service Connect message, General Handoff Direction message, or Universal Handoff Direction message that includes a service option connection using Service Option 68, the MS shall perform the following:

- If the service option connection is new, i.e., not part of the previous service configuration, the MS shall perform speech codec initialization at the time specified by the maximum of the action time associated with the message carrying the service configuration record, and the time that the corresponding call control instance is instantiated. The MS shall initialize its EVRC-B encoder mode of operation to a default value of 0. The MS shall complete the initialization within 40 ms.
- Beginning at the time specified by the maximum of the action time associated with the message carrying the service configuration record, and the time that the corresponding call control instance is instantiated, and continuing for as long as the service configuration includes the service option connection, Service Option 68 shall process received packets and generate and supply packets for transmission as follows:
  - If the call control instance is in the conversation substate, Service Option 68 shall process the received packets and generate and supply packets for transmission in accordance with this standard.
  - If the Call Control Instance is not in the conversation substate, Service Option 68 shall process the received packets in accordance with this standard, and shall generate and supply Rate 1/8 packets with all bits set to 1 for transmission, except when commanded to generate a blank packet.

## 1 Base station requirements

2 If the base station establishes a service configuration, as specified in a Service Connect message, General  
3 Handoff Direction message, or Universal Handoff Direction message that includes a service option connection  
4 using Service Option 68, the base station shall perform the following:

- 5 ○ If the service option connection is new, i.e., not part of the previous service configuration, the  
6 base station shall perform speech codec initialization no later than the time specified by the  
7 maximum of the action time associated with the message carrying the service configuration  
8 record, and the time that the corresponding call control instance is instantiated. The base  
9 station shall initialize its EVRC-B encoder mode of operation to a default value of 0.
- 10 ○ Commencing at the time specified by the maximum of the action time associated with the  
11 message carrying the service configuration record, and the time that the corresponding call  
12 control instance is instantiated, and continuing for as long as the service configuration  
13 includes the service option connection, Service Option 68 shall process received packets, and  
14 shall generate and supply packets for transmission in accordance with this standard. The base  
15 station may defer enabling the audio input and output.

### 16 2.4.1.2 Service option control messages

## 17 MS requirements

18 The MS shall support one pending Service Option Control message for Service Option 68.

19 If the MS receives a Service Option Control message for Service Option 68, then, at the action time associated  
20 with the message, the MS shall process the message as follows:

21  
22 If the MS has an application which requires the reverse link to operate at operating point 0, the MS may reject  
23 the message by sending an MS Reject Order with an ORDQ of 00000100 while that application is active.

24 If the MS accepts the Service Option Control message the following occurs:

- 25  
26 1. If the MOBILE\_TO\_MOBILE field is equal to 1, the MS should disable the audio output of the  
27 speech codec for 1 sec after initialization.
- 28 2. If the MOBILE\_TO\_MOBILE field is equal to 0, the MS shall process each received packet as  
29 described in Chapter 6.
- 30 3. If the INIT\_CODEEC field is equal to 1, the MS shall perform speech codec initialization. The MS shall  
31 complete the initialization within 40 ms.
- 32 4. EVRC-B accepts as input, an encoder operating point through the RATE\_REDUCE field as defined in  
33 Table 2.4.1.2-1. Using this operating point, EVRC-B generates Rate 1, Rate 1/2, and Rate 1/4 packets  
34 in a proportion that results in the average data rate given by Table 2.4.1.2-1.
- 35 5. Service Option 68 shall continue to use these fractions until either of the following events occur:  
36 a. The MS receives a Service Option Control message specifying a different RATE\_REDUCE, or  
37 b. Service Option 68 is initialized.

6. Service Option 68 was developed using reduced rate operation (encoder operating point) as a network control criteria. Unlike the rate reduction mechanism in EVRC, Service Option 68 does not use a deterministic pattern of Rate 1 and Rate 1/2 to reduce the average encoding rate. Instead, the EVRC-B codec selects the encoding rate based upon the characteristics of the input speech; voiced unvoiced, transient, stationary, as well as the encoding mode selected.

**Table 2.4.1.2-1 Service Option 68 Encoding rate control parameters**

<b>RATE_REDUCE (binary)</b>	<b>encoder operating point</b>	<b>Estimated average encoding rate for active speech (channel encoding rates)</b>	<b>Estimated average encoding rate for active speech (source encoding rates)</b>
'000'	0	9.3	8.3 kbps
'001'	1	8.5	7.57 kbps
'010'	2	7.5	6.64 kbps
'011'	3	7.0	6.18 kbps
'100'	4	6.6	5.82 kbps
'101'	5	6.2	5.45 kbps
'110'	6	5.8	5.08 kbps
'111'	7 (1/2 rate max)	4.8	4.0 kbps

Quarter-rates are not used when RATE\_REDUCE = '000' and RATE\_REDUCE = '111'. Therefore, RATE\_REDUCE = '000' and RATE\_REDUCE = '111' could be used in IS-95 [N3] systems where quarter-rate frames are sometimes disallowed.

The mobile station may send a Service Option Control message for Service Option 68 to the BS ordering the BS to utilize operating point 0 in the forward direction under the following condition:

1. The mobile has an application for which the BS needs to use operating point 0 in the forward direction, and
2. The mobile has successfully received a service connect message or has successfully completed a hard handoff.

If the mobile station sends a Service Option Control message, the mobile station shall include the following type-specific fields for Service Option 68.

**Table 2.4.1.2-2 Service Option Control message type-specific fields**

<b>Field</b>	<b>Length (bits)</b>
RATE_REDUCE	3
RESERVED	5

- RATE\_REDUCE – Service Option 68 mode of operation; the mobile station shall set this field to value '000' , corresponding to the mode 0, in which the BS is to operate on the forward link.
- RESERVED – reserved bits; the mobile station shall set this field to 00000

## 1 Base station requirements

2 The base station may send a Service Option Control message to the MS. If the base station sends a Service  
3 Option Control message, the base station shall include the following type-specific fields for Service Option 68.

5 **Table 2.4.1.2-3 Service Option Control message type-specific fields**

Field	Length (bits)
RATE_REDUCE	3
RESERVED	3
MOBILE_TO_MOBILE	1
INIT_CODEC	1

- 6
- 7 ○ RATE\_REDUCE – Service Option 68 encoder operating point; the base station shall set this  
8 field to the value from Table 2.4.1.2-4 corresponding to the operating point in which the MS  
9 is to operate
- 10 ○ RESERVED – reserved bits; the base station shall set this field to 000
- 11 ○ MOBILE\_TO\_MOBILE – mobile-to-mobile processing; if the MS is to perform mobile-to-  
12 mobile processing, the base station shall set this field to 1; in addition, if the MS is to disable  
13 the audio output of the speech codec for 1 sec after initialization, the base station shall set the  
14 INIT\_CODEC field and the MOBILE\_TO\_MOBILE field to 1; if the MS is not to perform  
15 mobile-to-mobile processing, the base station shall set the MOBILE\_TO\_MOBILE field to 0
- 16 ○ INIT\_CODEC – initialize speech codec; if the MS is to initialize the speech codec, the base  
17 station shall set this field to 1; otherwise, the base station shall set this field to 0
- 18

1

**Table 2.4.1.2-4 Service Option 68 encoding rate control parameters**

<b>RATE_REDUC (binary)</b>	<b>encoder operating point</b>	<b>Estimated average encoding rate for active speech (channel encoding rates)</b>	<b>Estimated average encoding rate for active speech (source encoding rates)</b>
'000'	0	9.3	8.3 kbps
'001'	1	8.5	7.57 kbps
'010'	2	7.5	6.64 kbps
'011'	3	7.0	6.18 kbps
'100'	4	6.6	5.82 kbps
'101'	5	6.2	5.45 kbps
'110'	6	5.8	5.08 kbps
'111'	7 (1/2 rate max)	4.8	4.0 kbps

Quarter-rates are not used when RATE\_REDUC = '000' and RATE\_REDUC = '111'. Therefore, RATE\_REDUC = '000' and RATE\_REDUC = '111' could be used in IS-95 [N3] systems where quarter-rate frames are sometimes disallowed.

- 2 The BS should support one pending Service Option Control message for Service Option 68.
- 3 If the BS receives a Service Option Control message for Service Option 68, then, at the action time associated
- 4 with the message, the BS should process the message as follows:
- 5     The BS shall use mode 0 and begin transmission to the MS in the forward direction using this mode.
- 6     The BS shall continue to use this mode for Service Option 68 with the MS for the duration of the call.

## 7 **2.5 Negotiation for Service Option 70**

8 The MS and base station can negotiate for Service Option 70 service negotiation, as described in [N1].

### 9 2.5.1 Procedures using service negotiation

10 The MS and base station shall perform service negotiation for Service Option 70 as described in [N1], and the

11 negotiated service configuration shall include only valid attributes for the service option as specified in Table

12 2.5.1-1.

1 **Table 2.5.1-1 Valid service configuration attributes for Service Option 70**

Service Configuration Attribute	Valid Selections
Forward Multiplex Option	Multiplex Option 1
Reverse Multiplex Option	Multiplex Option 1
Forward Transmission Rates	Rate Set 1 with all rates enabled
Reverse Transmission Rates	Rate Set 1 with all rates enabled
Forward Traffic Type	Primary Traffic
Reverse Traffic Type	Primary Traffic

2  
3 2.5.1.1 Initialization and connection

4 **MS requirements**

5 If the MS accepts a service configuration, as specified in a Service Connect message, General Handoff  
6 Direction message, or Universal Handoff Direction message that includes a service option connection using  
7 Service Option 68, the MS shall perform the following:

- 8       ○ If the service option connection is new, i.e., not part of the previous service configuration, the  
9 MS shall perform speech codec initialization at the time specified by the maximum of the  
10 action time associated with the message carrying the service configuration record, and the  
11 time that the corresponding call control instance is instantiated. The MS shall initialize its  
12 EVRC-WB encoder mode of operation to a default value of 0. The MS shall complete the  
13 initialization within 40 ms.
- 14       ○ Beginning at the time specified by the maximum of the action time associated with the  
15 message carrying the service configuration record, and the time that the corresponding call  
16 control instance is instantiated, and continuing for as long as the service configuration  
17 includes the service option connection, Service Option 70 shall process received packets and  
18 generate and supply packets for transmission as follows:
- 19       ○ If the call control instance is in the conversation substate, Service Option 70 shall process  
20 the received packets and generate and supply packets for transmission in accordance with  
21 this standard.
- 22       ○ If the Call Control Instance is not in the conversation substate, Service Option 70 shall  
23 process the received packets in accordance with this standard, and shall generate and  
24 supply Rate 1/8 packets with all bits set to 1 for transmission, except when commanded  
25 to generate a blank packet.

## 1 **Base station requirements**

2 If the base station establishes a service configuration, as specified in a Service Connect message, General  
3 Handoff Direction message, or Universal Handoff Direction message that includes a service option connection  
4 using Service Option 70, the base station shall perform the following:

- 5       o If the service option connection is new, i.e., not part of the previous service configuration, the  
6       base station shall perform speech codec initialization no later than the time specified by the  
7       maximum of the action time associated with the message carrying the service configuration  
8       record, and the time that the corresponding call control instance is instantiated. The base  
9       station shall initialize its EVRC-WB encoder mode of operation to a default value of 0.
- 10       o Commencing at the time specified by the maximum of the action time associated with the  
11       message carrying the service configuration record, and the time that the corresponding call  
12       control instance is instantiated, and continuing for as long as the service configuration  
13       includes the service option connection, Service Option 70 shall process received packets, and  
14       shall generate and supply packets for transmission in accordance with this standard. The base  
15       station may defer enabling the audio input and output.

### 16 2.5.1.2 Service option control messages

## 17 **MS requirements**

18 The MS shall support one pending Service Option Control message for Service Option 70.

19 If the MS receives a Service Option Control message for Service Option 70, then, at the action time associated  
20 with the message, the MS shall process the message as follows:

21  
22 If the MS has an application which requires the reverse link to operate at operating point 0, the MS may reject  
23 the message by sending an MS Reject Order with an ORDQ of 00000100 while that application is active.

24 If the MS accepts the Service Option Control message the following occurs:

- 25  
26       7. If the MOBILE\_TO\_MOBILE field is equal to 1, the MS should disable the audio output of the  
27       speech codec for 1 sec after initialization.
- 28       8. If the MOBILE\_TO\_MOBILE field is equal to 0, the MS shall process each received packet as  
29       described in Chapter 6.
- 30       9. If the INIT\_CODEEC field is equal to 1, the MS shall perform speech codec initialization. The MS shall  
31       complete the initialization within 40 ms.
- 32       10. EVRC-WB accepts as input, an encoder operating point through the RATE\_REDUCE field as defined  
33       in Table 2.4.1.2-1. Using this operating point, EVRC-WB generates Rate 1, Rate 1/2, and Rate 1/4  
34       packets in a proportion that results in the average data rate given by Table 2.5.1.2-1.
- 35       11. Service Option 70 shall continue to use these fractions until either of the following events occur:
  - 36           a. The MS receives a Service Option Control message specifying a different RATE\_REDUCE, or
  - 37           b. Service Option 70 is initialized.

1  
2  
3

Table 2.5.1.2-1 Service Option 70 Encoding rate control parameters

<b>RATE_REDUCE (binary)</b>	<b>encoder operating point</b>	<b>Estimated average encoding rate for active speech (channel encoding rates)</b>	<b>Estimated average encoding rate for active speech (source encoding rates)</b>	<b>Description of the operating point</b>
'000'	0	8.5 kbps	7.5 kbps	This is a wideband operating point. The bit-stream carries information about both Lowband and Highband of the 16 KHz signal.
'001'				RESERVED
'010'				RESERVED
'011'				RESERVED
'100'	4	9.3 kbps	8.3 kbps	This is a narrowband operating point that is interoperable with Operating Point 0 of SO 68 because the bit-stream carries information about a narrowband signal using the Full-rate CELP, Half-rate CELP, and Eighth-rate used in SO 68.
'101'				RESERVED
'110'				RESERVED
'111'	7 (1/2 rate max)	4.8 kbps	4.0 kbps	This is a narrowband operating point, using a maximum of Rate 1/2. This mode is interoperable with Operating Point 7 of SO 68 because the bit-stream carries information about a narrowband signal using the Half-rate CELP, and Eighth-rate used in SO 68..

4  
5  
6  
7  
8  
9

The mobile station may send a Service Option Control message for Service Option 70 to the BS ordering the BS to utilize operating point 0 in the forward direction under the following condition:

3. The mobile has an application for which the BS needs to use operating point 0 in the forward direction, and

1 4. The mobile has successfully received a service connect message or has successfully completed a hard  
 2 handoff.

3 If the mobile station sends a Service Option Control message, the mobile station shall include the following  
 4 type-specific fields for Service Option 70.

5

6

**Table 2.5.1.2-2 Service Option Control message type-specific fields**

Field	Length (bits)
RATE_REDUCE	3
RESERVED	5

7

- 8 ○ RATE\_REDUCE – Service Option 70 mode of operation; the mobile station shall set this field  
 9 to value '000', corresponding to the mode 0, in which the BS is to operate on the forward  
 10 link.
- 11 ○ RESERVED – reserved bits; the mobile station shall set this field to 00000

12 **Base station requirements**

13 The base station may send a Service Option Control message to the MS. If the base station sends a Service  
 14 Option Control message, the base station shall include the following type-specific fields for Service Option 68.

15

**Table 2.5.1.2-3 Service Option Control message type-specific fields**

Field	Length (bits)
RATE_REDUCE	3
RESERVED	3
MOBILE_TO_MOBILE	1
INIT_CODEC	1

16

- 17 ○ RATE\_REDUCE – Service Option 70 encoder operating point; the base station shall set this  
 18 field to the value from Table 2.5.1.2-4 corresponding to the operating point in which the MS  
 19 is to operate
- 20 ○ RESERVED – reserved bits; the base station shall set this field to 000
- 21 ○ MOBILE\_TO\_MOBILE – mobile-to-mobile processing; if the MS is to perform mobile-to-  
 22 mobile processing, the base station shall set this field to 1; in addition, if the MS is to disable  
 23 the audio output of the speech codec for 1 sec after initialization, the base station shall set the  
 24 INIT\_CODEC field and the MOBILE\_TO\_MOBILE field to 1; if the MS is not to perform  
 25 mobile-to-mobile processing, the base station shall set the MOBILE\_TO\_MOBILE field to 0
- 26 ○ INIT\_CODEC – initialize speech codec; if the MS is to initialize the speech codec, the base  
 27 station shall set this field to 1; otherwise, the base station shall set this field to 0

28

29

1

Table 2.5.1.2-4 Service Option 70 encoding rate control parameters

<b>RATE_REDUCE (binary)</b>	<b>encoder operating point</b>	<b>Estimated average encoding rate for active speech (channel encoding rates)</b>	<b>Estimated average encoding rate for active speech (source encoding rates)</b>	<b>Description of the operating point</b>
'000'	0	8.5 kbps	7.5 kbps	This is a wideband operating point. The bit-stream carries information about both Lowband and Highband of the 16 KHz signal.
'001'				RESERVED
'010'				RESERVED
'011'				RESERVED
'100'	4	9.3 kbps	8.3 kbps	This is a narrowband operating point that is interoperable with Operating Point 0 of SO 68 because the bit-stream carries information about a narrowband signal using the Full-rate CELP, Half-rate CELP, and Eighth-rate used in SO 68.
'101'				RESERVED
'110'				RESERVED
'111'	7 (1/2 rate max)	4.8 kbps	4.0 kbps	This is a narrowband operating point, using a maximum of Rate 1/2. This mode is interoperable with Operating Point 7 of SO 68 because the bit-stream carries information about a narrowband signal using the Half-rate CELP, and Eighth-rate used in SO 68..

2

3 The BS should support one pending Service Option Control message for Service Option 70.

4

4 If the BS receives a Service Option Control message for Service Option 70, then, at the action time associated  
5 with the message, the BS should process the message as follows:

6

6 The BS shall use mode 0 and begin transmission to the MS in the forward direction using this mode.

7

7 The BS shall continue to use this mode for Service Option 70 with the MS for the duration of the call.

8



## 3 AUDIO INTERFACES

### 3.1 Input Audio Interface

#### 3.1.1 Input Audio Interface in the Mobile Station

The input audio may be either an analog or digital signal.

##### 3.1.1.1 Conversion and Scaling

Whether the input is analog or digital, the signal presented to the input of the speech codec shall be sampled at a rate of 8000 samples per second and shall be quantized to a uniform PCM format with at least 13 bits of dynamic range. For SO 70, the input signal shall be sampled at either 8000 samples per second or 16000 samples per second.

The quantities in this standard assume a 16-bit integer input normalization with a range from -32,768 through +32,767. The following speech codec discussion assumes this 16-bit integer normalization. If an input audio interface uses a different normalization scheme, then appropriate scaling should be used.

##### 3.1.1.2 Digital Audio Input

If the input audio is an 8-bit  $\mu$ law PCM signal, it shall be converted to a uniform PCM format according to Table 2 in ITU-T Recommendation G.711 [S2].

##### 3.1.1.3 Analog Audio Input

If the input is in analog form, the mobile station shall sample the analog speech and shall convert the samples to a digital format for speech codec processing. This shall be done by either the following or an equivalent method. First, the input gain audio level is adjusted. Then, the signal is bandpass filtered to prevent aliasing. Finally, the filtered signal is sampled and quantized (see 3.1.1.1).

###### 3.1.1.3.1 Transmit Level Adjustment

The mobile station shall have a transmit objective loudness rating (TOLR) equal to -46 dB, when transmitting to a reference base station. The loudness ratings are described in IEEE Standard 661-1979 [S5]. Measurement techniques and tolerances are described in the appropriate EVRC Minimum Performance Specification revision [S6].

###### 3.1.1.3.2 Band Pass Filtering

Input anti-aliasing filtering shall conform to ITU-T Recommendation G.712 [S3]. Additional anti-aliasing filtering may be provided by the manufacturer.

For SO 70, if the input speech is wideband, the signal should be filtered by a filter that generally conforms to the the mask shown in ITU-T Recommendation P.311 [S11] or ITU-T Recommendation P.341 [S12].

###### 3.1.1.3.3 Echo Return Loss

Provision shall be made to ensure adequate isolation between receive and transmit audio paths in all modes of operation. When no external transmit audio is present, the speech codec shall not generate packets at rates higher than Rate 1/8 due to acoustic coupling of the receive audio into the transmit audio path (specifically with

1 the receive audio at full volume). Target levels of 45 dB WAEPL should be met. See ANSI/EIA/TIA Standard  
2 579-A-98 [S1].

### 3 3.1.2 Input Audio Interface in the Base Station

#### 4 3.1.2.1 Sampling and Format Conversion

5 The base station converts the input speech (analog,  $\mu$ law companded Pulse Code Modulation, or other format)  
6 into a uniform quantized PCM format with at least 13 bits of dynamic range. The sampling rate is 8000  
7 samples per second. The input signal for SO 70 may use a sampling rate of 16000 samples per second. The  
8 sampling and conversion process shall be as in 3.1.1.1.

#### 9 3.1.2.2 Transmit Level Adjust

10 The base station shall set the transmit level so that a 1004 Hz tone at a level of 0 dBm0 at the network interface  
11 produces a level 3.17 dB below maximum amplitude at the output of the quantizer. Measurement techniques  
12 and tolerances are described in the appropriate EVRC Minimum Performance Specification revision [S6].

#### 13 3.1.2.3 Line Echo Canceling

14 The base station shall provide a method to cancel echoes returned by the PSTN interface.<sup>†</sup> The echo canceling  
15 function should provide at least 30 dB of echo return loss enhancement. The echo canceling function should  
16 work over a range of PSTN echo return delays from 0 to 48 ms; however, the latter requirement is subject to  
17 local PSTN configuration demands, i.e., a 64 ms (or greater) echo canceling capability may be required in cases  
18 where the PSTN does not provide echo cancellation for long distance service. See ITU-T Recommendation  
19 G.168 [S9].

## 20 3.2 Output Audio Interface

### 21 3.2.1 Output Audio Interface in the Mobile Station

#### 22 3.2.1.1 Band Pass Filtering

23 Output reconstruction filtering shall conform to ITU-T Recommendation G.712 [S3]. Additional  
24 reconstruction filtering may be provided by the manufacturer.

25 For SO 70, if the output speech is wideband, the signal should be filtered by a filter that generally conforms to  
26 the mask shown in ITU-T Recommendation P.311 [S11] or ITU-T Recommendation P.341 [S12].].

#### 27 3.2.1.2 Receive Level Adjustment

28 The mobile station shall have a nominal receive objective loudness rating (ROLR) equal to 51 dB when  
29 receiving from a reference base station. The loudness ratings are described in IEEE Standard 661-1979 [S5].  
30 Measurement techniques and tolerances are described in the appropriate EVRC Minimum Performance  
31 Specification revision [S6].

---

<sup>†</sup> Because of the relatively long delays inherent in the speech coding and transmitting processes, echoes that are not sufficiently suppressed are noticeable to the mobile station user.

1 3.2.2 Output Audio Interface in the Base Station

2 Details of the digital and analog interfaces to the network are outside the scope of this document.

3 3.2.2.1 Receive Level Adjustment

4 The base station shall set the audio level so that a received 1004 Hz tone 3.17 dB below maximum amplitude  
5 produces a level of 0 dBm0 at the network interface. Measurement techniques and tolerances are described in  
6 the appropriate EVRC Minimum Performance Specification revision [S6].



## 4 OVERVIEW AND SPEECH ENCODER

### 4.1 Service Option 3

The Enhanced Variable Rate Codec (EVRC) is based upon the RCELP algorithm, appropriately modified for variable rate operation and for robustness in the CDMA environment. RCELP is a generalization of the Code-Excited Linear Prediction (CELP) algorithm. Unlike conventional CELP encoders, RCELP does not attempt to match the original speech signal exactly. Instead of attempting to match the original residual signal, RCELP matches a time-warped version of the original residual that conforms to a simplified pitch contour. The pitch contour is obtained by estimating the pitch delay once in each frame and linearly interpolating the pitch from frame to frame. One benefit of using this simplified pitch representation is that more bits are available in each packet for the stochastic excitation and for channel impairment protection than would be if a traditional fractional pitch approach were used. This results in enhanced error performance without impacting perceived speech quality in clear channel conditions.

The encoder uses 3 of the 4 primary traffic packet types permitted by IS-95 [N3] Multiplex Option 1: Rate 1 (171 bits/packet), Rate 1/2 (80 bits/packet), and Rate 1/8 (16 bits/packet). Upon command, the encoder will produce a blank packet (which contains no bits) or other than a Rate 1 packet (i.e., Rate 1/2 maximum); otherwise, the encoder makes its own determination about what type of packet to generate. Bit allocations for each packet type are given in Table 4.1-1.

**Table 4.1-1 Bit Allocations by Packet Type**

Field (see 4.8)	Packet Type			
	Rate 1	Rate 1/2	Rate 1/8	Blank
Spectral Transition Indicator	1			
LSP	28	22	8	
Pitch Delay	7	7		
Delta Delay	5			
ACB Gain	9	9		
FCB Shape	105	30		
FCB Gain	15	12		
Frame Energy			8	
(reserved)	1			
<b>Total</b>	171	80	16	0

The algorithms in the sections that follow are presented in terms of block diagrams, mathematical equations where appropriate, and in pseudo-code where equations would be cumbersome. Inputs, outputs, and processing are defined for each processing block or module. Internal variables for each module are defined when used. Modules are decomposed into sub-modules at increasing levels of detail until a defining equation or block of pseudo-code describing the lowest level of processing is reached. The algorithm descriptions are designed to maximize clarity, not to illustrate the most efficient implementation. For example, no attempt is made to illustrate memory conserving techniques such as reuse of scratch variables or buffers. Operations such as Discrete Fourier Transforms (DFTs) or Finite Impulse Response (FIR) filters are described in terms of a defining equation rather than in terms of one of the fast algorithms available to carry them out.

Figure 4.1-1 is a high-level view of the EVRC speech encoder showing all major modules. Inputs to the encoder are the speech signal vector,  $\{s(n)\}$ , and an external rate command signal. The external rate command may direct the encoder to produce a blank packet or a packet other than Rate 1. If an external rate command is received, it will supersede the encoder's internal rate selection mechanism.

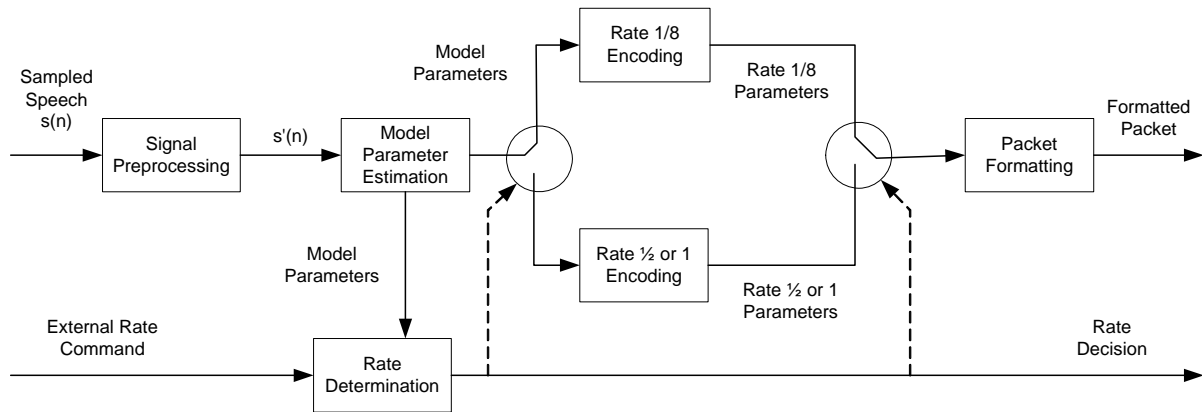

**Figure 4.1-1 Speech Encoder Top-Level Diagram**

The input speech vector,  $\{s(n)\}$ , is presented to the signal pre-processing module (see 4.1), which performs high-pass and adaptive noise suppression filtering. The pre-processed speech vector,  $\{s'(n)\}$ , is then presented to the model parameter estimation module. The model parameter estimation module (see 4.2) performs LPC analysis to determine a set of linear prediction coefficients (LPCs) and the optimal pitch delay ( $\tau$ ). It also converts the LPCs to line spectral pairs (LSPs) and calculates the long and short-term prediction gains. The rate determination module (see 4.3) applies a voice activity detection (VAD) algorithm and rate selection logic in order to determine the type of packet to generate.

After estimating the model parameters, the encoder will characterize the excitation signal and quantize parameters in a way appropriate to the selected rate (see 4.4 through 4.6). If Rate 1/8 is selected, the encoder will not attempt to characterize any periodicity in the speech residual, but will instead just characterize its energy contour. At Rates 1/2 and 1 the encoder will apply the RCELP algorithm to match a time-warped version of the original speech residual.

A number of parameters are included at Rate 1 to provide enhanced performance in poor channel conditions. These include the spectral transition indicator and the delay difference ( $\Delta\tau$ ). The packet formatting module (see 4.8) accepts all of the parameters calculated and quantized in the rate-specific encoding modules, and formats a packet appropriate to the selected rate. The formatted packet is then presented to the multiplex sub-layer. The

1 rate decision is also presented to the multiplex sub-layer. Sections 4.1 through 4.8 describe each of the encoder  
2 modules in detail.

### 3 4.2 Service Option 68

4 The EVRC-B coder uses an operating point and speech-type dependent coding scheme selection. Primarily it  
5 consists of Code-Excited-Linear-Prediction (CELP), Prototype-Pitch-Period (PPP), Noise-Excited-Linear-  
6 Prediction (NELP) coding methods. CELP is used for full-rate and half-rate, PPP is used for full-rate and  
7 quarter-rate, NELP is used for quarter-rate, and eighth-rate.

8 Table 4.2-1 lists where the different coding schemes are used. Full-rate CELP (FCELP) is used to code  
9 transitions, poorly voiced frames and certain normal voiced frames as well. Half-rate CELP (HCELP) is used to  
10 code ends of words mostly and dimmed frames. Full-rate PPP (FPPP) and quarter-rate PPP (QPPP) are used to  
11 code strongly voiced frames. Quarter-rate NELP (QNELP) is used for unvoiced frames. Silence is coded by a  
12 simple single-gain shaped random noise waveform as in SO 3.

13

14

**Table 4.2-1 EVRC-B coding schemes**

<b>Coding scheme</b>	<b>Type of speech</b>
FCELP (Full-rate CELP)	Transient, bump-up and some voiced frames
HCELP (1/2-Rate CELP)	Ends of words, Dim-and-burst signaling
Special HCELP	Packet level dimming of FCELP
FPPP/QPPP (Full/Quarter rate Prototype Pitch Period)	Voiced frames
Special HPPP	Packet level dimming of FPPP
QNELP (¼-Rate Noise Excited LP)	Unvoiced frames
Special HNELP	Half-rate frame containing NELP frame for use in situations not allowing quarter-rate (e.g., RATE_REDUCE = '111')
1/8 Rate	Silence frames

15

16 The encoder uses the 4 primary traffic packet types permitted by IS-95 [N3] Multiplex Option 1: Rate 1 (171  
17 bits/packet), Rate 1/2 (80 bits/packet), Rate 1/4 (40 bits/packet), and Rate 1/8 (16 bits/packet). Upon command,  
18 the encoder will produce a blank packet (which contains no bits) or other than a Rate 1 packet, i.e., Rate 1/2  
19 maximum; otherwise, the encoder makes its own determination about what type of packet to generate. Bit  
20 allocations for each packet type are given in

21 Table 4.2-2.

1  
2  
3  
4  
5  
6

**Table 4.2-2 Bit allocations by packet type**

<b>Parameter</b>	<b>Full-rate CELP</b>	<b>Half-rate CELP</b>	<b>Special half-rate CELP</b>	<b>Full-rate PPP</b>	<b>Special half-rate PPP</b>	<b>Quarter-rate PPP</b>	<b>Special half-rate NELP</b>	<b>Quarter-rate NELP</b>	<b>Silence encoder</b>
Mode Bit	1		1	1	1	1		1	
Special half-rate ID			2		2		2		
LSP	28	22	28	28	28	16	16	16	8
Lag/Special Packet ID	7	7	7	7	7	4	7		
Additional Lag			7		7				
ACB Gain	9	9	9						
FCB Index	105	30							
FCB Gain	15	12							
Delta lag	5								
Amplitude				28	28	18			
Global Alignment				7	7	0			
Band Alignments				99					
Energy VQ							17	17	6
Filter Shape							2	2	
Reserved	1		26	1		1	36	4	2
Total	171	80	80	171	80	40	80	40	16

7

8 All the reserved bits shall be set to 0. The algorithms in the sections that follow are presented in terms of block  
9 diagrams, mathematical equations where appropriate, and in pseudo-code where equations would be  
10 cumbersome. Inputs, outputs, and processing are defined for each processing block or module. Internal  
11 variables for each module are defined when used. Modules are decomposed into sub-modules at increasing  
12 levels of detail until a defining equation or block of pseudo-code describing the lowest level of processing is  
13 reached. The algorithm descriptions are designed to maximize clarity, not to illustrate the most efficient

1 implementation. For example, no attempt is made to illustrate memory conserving techniques such as reuse of  
 2 scratch variables or buffers. Operations such as Discrete Fourier Transforms (DFTs) or Finite Impulse  
 3 Response (FIR) filters are described in terms of a defining equation rather than in terms of one of the fast  
 4 algorithms available to carry them out.

5 Figure 4.2-1 is a high-level view of the EVRC-B speech encoder showing all major modules. Inputs to the  
 6 encoder are the speech signal vector,  $\{s(n)\}$ , and an external rate command signal. The external rate command  
 7 may direct the encoder to produce a blank packet or a packet other than Rate 1. If an external rate command is  
 8 received, it will supersede the encoder's internal rate selection mechanism.

9

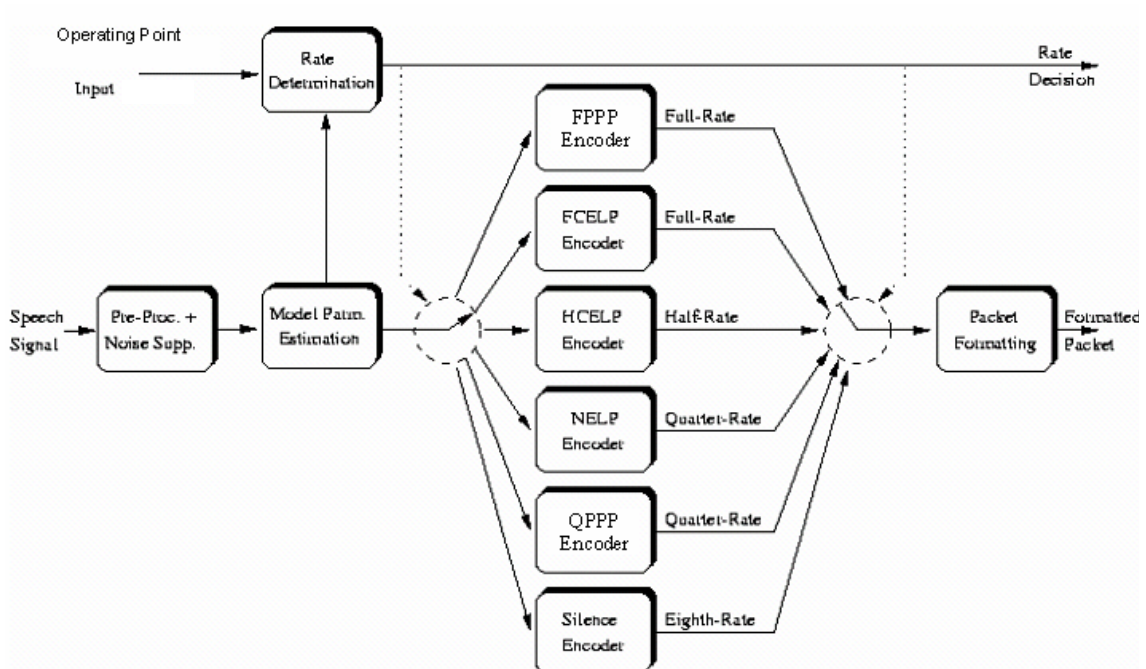

10

11

Figure 4.2-1 Speech encoder top-level diagram

1 Figure 4.2-2 is a speech decoder top-level diagram.

2

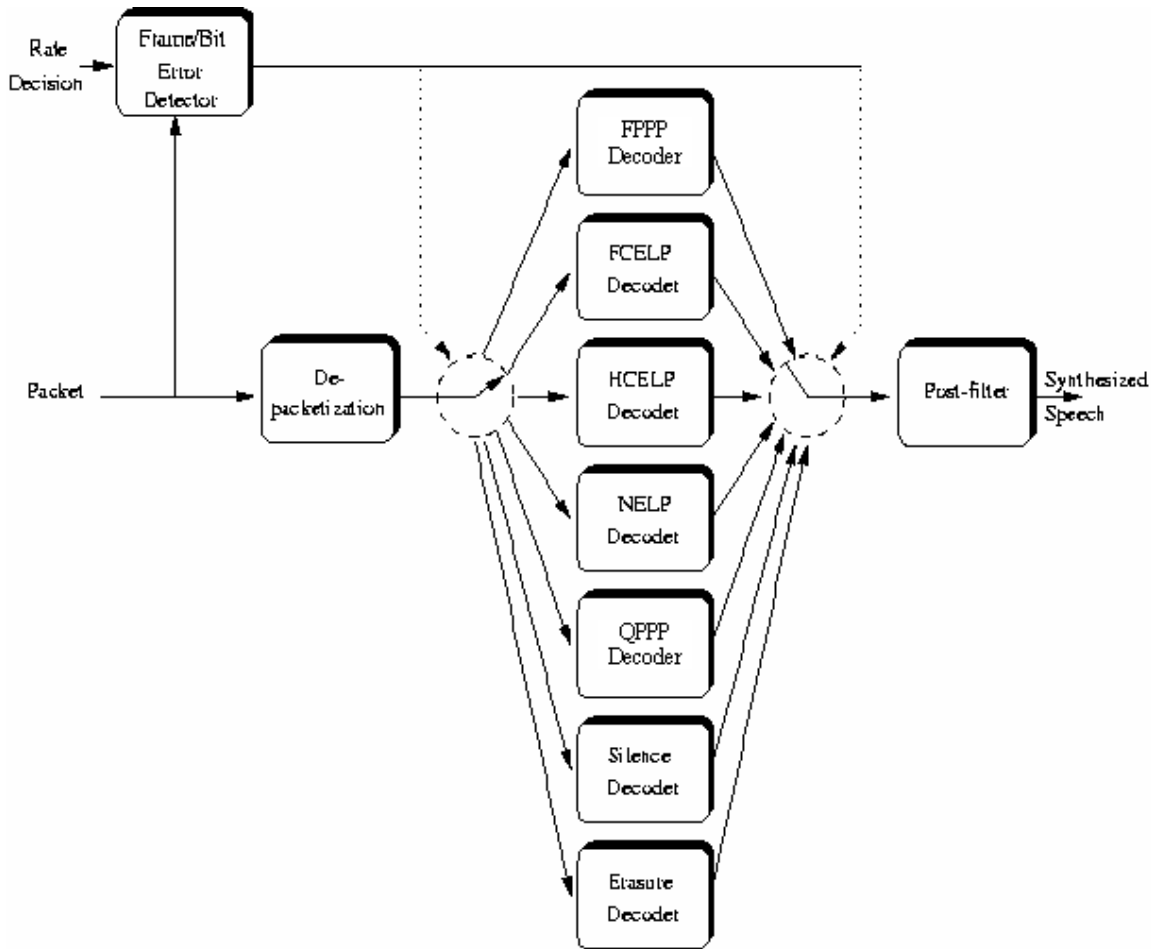

3

4

**Figure 4.2-2 Speech decoder top-level diagram**

5 After usual front-end pre-processing and voiced activity decision, the input speech and residual are analyzed to  
 6 compute open-loop-pitch information as well as periodicity information. This information along with other  
 7 features is used to categorize speech into transition, voiced, unvoiced, end-of-word, silence.

8 Then there is a further categorization of frames into one of the above coding schemes and rates which is  
 9 operating point-dependent.

10 The linear-prediction-coefficients (LPCs) are quantized according to the rate and coding scheme. The residual  
 11 is computed using these quantized LPCs and modified to get a target waveform matching as perfectly as  
 12 possible to a pitch contour without losing perceptual quality, as in SO 3. After this encoding of either this target  
 13 waveform or a representative period of it or an energy contour of it is done with appropriate quantization and  
 14 corresponding unquantization at the decoder, synthesis and update of memories. A perceptual quality enhancing  
 15 adaptive postfilter is applied to the output of the decoder.

16 4.2.1 Pre-processing

17 The input speech is processed through a high-pass-filter and noise-suppressor, after which certain parameters  
 18 such as LPC, Normalized-Auto-Correlation-Function (NACF) are extracted. Voice-activity decision is made

1 before any further processing. Pitch lag and NACF for the current frame are estimated based on the residual of  
2 the current frame, previous frame and part of the next frame. Some additional features are also estimated for use  
3 in rate/coding scheme decision which follows.

4 The High-Pass-Filter and Noise-Suppressor are similar to SO 3. The LPC analysis, pitch lag estimation, LPC to  
5 LSP conversion, and residual computation are similar to SO 3. New parameters computed NACF and certain  
6 other rate decision specific features. Voice-activity decision is similar to that in SO 3.

#### 7 4.2.2 Rate/coding scheme decision

8 The rate/coding scheme decision is of two kinds, open-loop and closed-loop, the former being invoked prior to  
9 any quantization being done (except for LPC in case of some open-loop decisions), the latter after. The open-  
10 loop rate decision is based mostly on parameters and features of input speech, both current and previous. The  
11 closed-loop rate decision is based on quarter-rate PPP quantizer performance.

12 The input operating point controls EVRC-B to operate at an arbitrarily desired average-rate. This is first  
13 mapped onto one of three Anchor Operating Points, called AOP 0, 1, and 2 respectively. These anchor  
14 operating points control the basic behavior of EVRC-B rate-selection while the final rate-selection enables the  
15 average rate output of EVRC-B to match the input operating point.

##### 16 4.2.2.1 Open-loop decision

17 First of all the input signal is classified broadly into speech, end-of-speech and silence. If the anchor operating  
18 point chosen is Anchor operating point-0, these classifications are correspondingly encoded with full-rate  
19 CELP, half-rate CELP, and silence-encoder. Otherwise, the non-silence part of the input is further classified  
20 using multi-level decision logic into transition, voiced, unvoiced and end-of-word. Additional features  
21 computed are SNR of previous and current frames, ZCR, high-band and low-band energies of current and  
22 previous frame. Each voiced segment is made sure to be preceded by a transition frame to get good initial  
23 memories. Transitions are encoded with full-rate CELP, end-of-word is encoded with half-rate CELP, unvoiced  
24 is encoded with quarter-rate NELP, and voiced is further mapped into pattern sets of three frames. If the anchor  
25 operating point chosen is anchor operating point-1 the repetitive three-frame pattern set is encoded successively  
26 with full-rate CELP, quarter-rate PPP, and full-rate CELP. If the anchor operating point chosen is Anchor  
27 operating point-2, this three-frame pattern set is encoded successively with quarter-rate PPP, quarter-rate PPP  
28 and full-rate PPP.

29 Further, if inside the PPP scheme some waveform changes are extreme, the coding scheme is changed either  
30 from full-rate PPP to full-rate CELP or quarter-rate PPP to full-rate PPP/CELP.

##### 31 4.2.2.2 Closed-loop decision

32 If the quarter-rate PPP encoding fails either in its phase representation or amplitude quantization, the Closed-  
33 Loop Rate Decision is used to change the rate to full-rate PPP (if anchor operating point-2) or full-rate CELP  
34 (if anchor operating point-1) and the voiced frame rate pattern is reset.

##### 35 4.2.2.3 Operating point-switching and dimming

36 To handle operating point-switching and dimming, the pattern of coding voiced frames is reset in certain  
37 conditions. In anchor operating point-1 or anchor operating point-2, if a full-rate frame is dimmed to half-rate,  
38 the voiced frame pattern begins afresh with full-rate (either PPP or CELP depending on anchor operating point-  
39 2 or anchor operating point-1 respectively). This holds true in the case of operating point-switching as well  
40 where the voiced frame pattern is reset to the usual pattern of choice for the new operating point.

1 4.2.2.4 Arbitrary capacity operating point operation

2

3 EVRC-B has the capability to operate at an arbitrary average rate. This in turn means that the CDMA network  
 4 using EVRC-B can achieve an arbitrary capacity operating point (COP) in the forward link as shown in Figure  
 5 4.2.2.4-1. The open-loop and the closed-loop rate decision thresholds are dynamically adjusted in order to  
 6 achieve this arbitrary average rate, as shown in Figure 4.2.2.4-1.

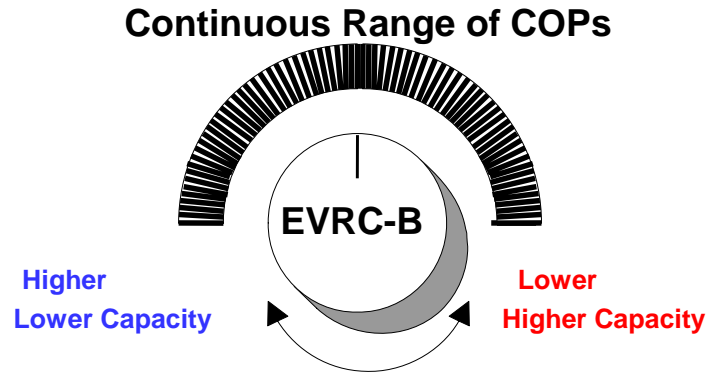

7

8 **Figure 4.2.2.4-1 Continuous range of COPs**

9

10 The channel average rate for active speech,  $T$ , is computed as follows,

11 
$$T = \frac{9600N_{full} + 4800N_{half} + 2400N_{quarter}}{N_{full} + N_{half} + N_{quarter}}$$

12 Given a target average rate for active speech, in channel rate bits-per-second, say  $T_{ActiveAvgChRate}$ , EVRC-B  
 13 encoder first determines an anchor operating point according to the following algorithm:

14       if ( $T_{ActiveAvgChRate} > 7500$ )  $OP_{anchor} = 0$   
 15       else if ( $T_{ActiveAvgChRate} > 6600$ )  $OP_{anchor} = 1$   
 16       else  $OP_{anchor} = 2$

17 Once the anchor operating point has been determined, EVRC-B attempts to meet the average rate-target by  
 18 adjusting the fraction of quarter-rate frames to meet the target average rate. This adjustment is done  
 19 dynamically by comparing the actual average rate in a window of past 600 active speech frames to the target  
 20 average rate, and computing an appropriate fraction of frames that would be sent from quarter-rate to full-rate  
 21 coding.

22 A fraction,  $p$ , of frames that would be sent from quarter-rate to full-rate is given by,

$$p = \begin{cases} \frac{(T_{next} - 7.5)}{(9.0 - 7.5)}; & OP_{anchor} = 0 \\ \frac{(T_{next} - 6.6)}{(7.5 - 6.6)}; & OP_{anchor} = 1 \\ \frac{(T_{next} - 5.75)}{(6.6 - 5.75)}; & OP_{anchor} = 2 \end{cases}$$

Where  $T_{next}$  is the dynamic target active speech channel average rate for the next *RATEWIN* active frames given by,

$$T_{next} = 1.98T_{ActiveAvgChRate} - T_{prev}$$

Where  $T_{prev}$  is the active speech channel average rate for the previous *RATEWIN* active frames.

Once the fraction,  $p$ , has been determined, the following algorithm is used to send the fraction,  $p$ , quarter-rate frames to full-rate in an almost uniformly distributed manner.

For every active frame,

```

10   If (OP_anchor = 0) {
11     If (open loop mode-decision EQUAL to UNVOICED) {
12       Patterncount = Patterncount + 1000 x p
13       If (patterncount > 1000) {
14         Encode unvoiced frame using full-rate
15         Patterncount = patterncount - 1000
16       }
17     }
18   If (OP_anchor = 1) {
19     If (voiced frame is determined using the open-loop and closed-loop
20     decision to be coded using QPPP) {
21       Patterncount = Patterncount + 1000 x p
22       If (patterncount > 1000) {
23         Encode QPPP frame using full-rate CELP
24         Patterncount = patterncount - 1000
25       }
26     }
27   If (OP_anchor = 2) {
28     If (voiced frame is determined using the open-loop and closed-loop
29     decision to be coded using QPPP and if previous frame was a QPPP frame) {
30       Patterncount = Patterncount + 1000 x p
31       If (patterncount > 1000) {
32         Encode QPPP frame using full-rate CELP
33         Patterncount = patterncount - 1000
34       }
35     }
36   }

```

#### 4.2.3 Full-rate CELP and half-rate CELP

The CELP algorithms are similar to those in SO 3 except for the following exceptions.

1 The fixed codebook in case of full rate is more efficient and is with one pulse fewer per subframe. This is  
2 achieved by exploring and covering all possible combinations of 7 pulses and two signs on each possible  
3 location in a subframe. Packing and unpacking is slightly more complex than in SO 3. The fixed codebook of  
4 half rate (used for end-of-word only) also is made somewhat more efficient by discarding undesirable pulse  
5 combinations from SO 3 and adding some new pulse combinations.

6 The full-rate CELP decoder is different in the way it handles the frame after erasure or the frame after a  
7 quarter-rate PPP which in turn would have followed an erasure. In the latter case, the previous quarter-rate PPP  
8 frame is re-synthesized with the proper lag and this is used for the adaptive codebook memories. In either case,  
9 after reconstruction of the residual of the current CELP frame, it could be replaced with a waveform-  
10 interpolated version of the representative prototypes of the current and previous reconstructed prototypes to  
11 eliminate clicks after erasure.

12 The special half-rate CELP frame is used when a full-rate CELP frame is converted by a packet-level signaling  
13 interworking function to a half-rate frame. The packet-level conversion is done by discarding the FCB index  
14 and gain bits in the full-rate, and repacking the remaining bits into a special half-rate frame. To indicate to the  
15 EVRC-B decoder that it is a special half-rate CELP frame, the 7 lag bits of the HCELP frame are set to 0x6E—  
16 a value that is never produced at the EVRC-B encoder.

#### 17 4.2.4 Full-rate PPP and quarter-rate PPP and special Half-rate PPP

##### 18 4.2.4.1 Background

19 It was the perceptual importance of the periodicity in voiced speech that motivated the development of the  
20 (Prototype Pitch Period) PPP coding technique. PPP exploits the fact that pitch-cycle waveforms in a voiced  
21 segment do not change quickly in a frame. This suggests that we do not have to transmit every pitch-cycle to  
22 the decoder; instead, we could transmit just a representative prototype pitch period. At the decoder, the  
23 nontransmitted pitch-cycle waveforms could then be derived by means of interpolation. In this way, very low-  
24 bit-rate coding can be achieved while maintaining high quality reconstructed voiced speech. Figure 4.2.4.1-1  
25 illustrates an example of how the pitch-cycle waveforms are extracted and interpolated. We will refer these  
26 pitch-cycle waveforms as Prototype Pitch Periods (abbreviated as PPPs).

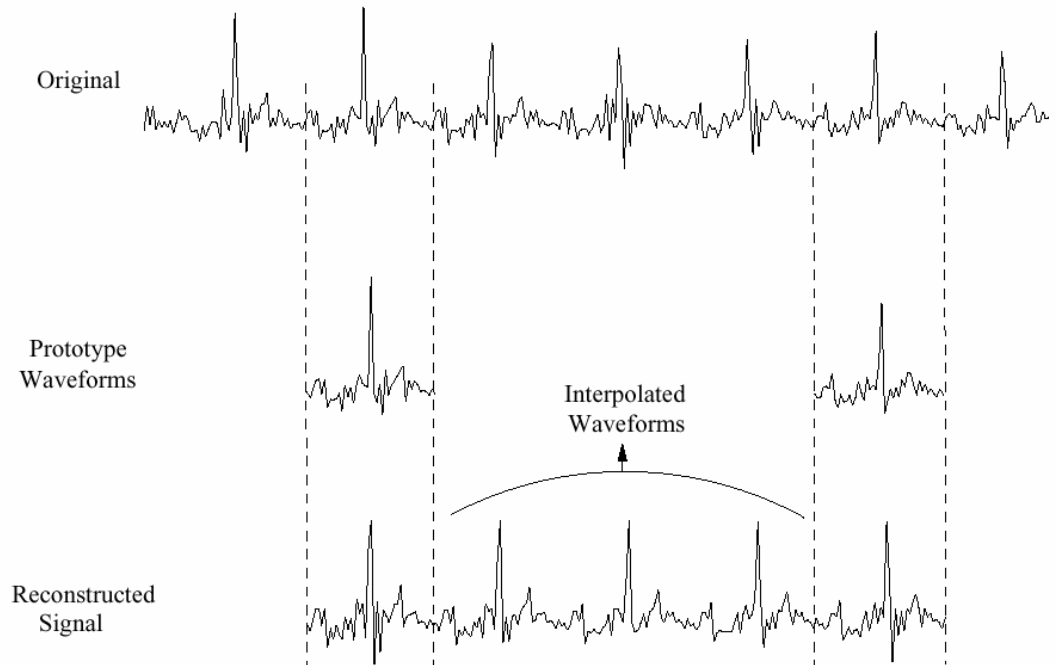

1

2

**Figure 4.2.4.1-1 Illustration of the principles of PPP coding**

3

4

5

6

7

In EVRC-B, PPP operates at two rates – full-rate (FPPP) and quarter-rate (QPPP). They both share the same fundamental concepts but differ in their bit-allocation schemes. In the context of this implementation, the quantization of PPP is carried out in frequency domain. Hence the time-domain signal is converted to a discrete-Fourier series (DFS), whose amplitudes and phases are independently quantized. The description of the PPP model will be first given.

8

#### 4.2.4.2 PPP Model

9

10

11

Figure 4.2.4.2-1 presents a high-level schematic diagram of PPP coding scheme. Front-end processing including LPC analysis is same for this scheme. However, the LSP quantization for the QPPP is a Moving-Average predictive quantizer which exploits the stationarity of voiced speech.

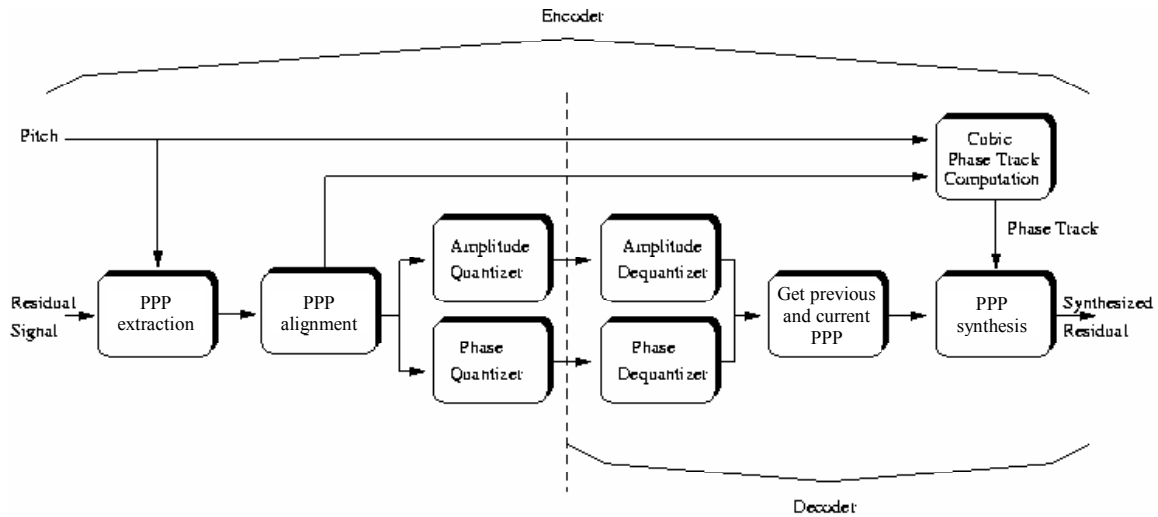

1  
2 **Figure 4.2.4.2-1 Block diagram of PPP coding scheme**

3 4.2.4.3 Further processing of PPP frames

4 Then, the corresponding residual is obtained which in turn is modified the same way as in CELP to follow a  
5 pitch contour similar to RCELP in SO 3.

6 Next, a PPP is extracted from the modified residual signal on a frame-wise basis. The length of the PPP is  
7 determined by the lag estimate supplied by the pitch estimator. Special attention needs to be paid to the  
8 boundaries of the PPP during the extraction process. Since each PPP will undergo circular rotation in the  
9 alignment process (as will be seen later), the energy around the PPP boundaries needs to be minimized to  
10 prevent discontinuities after circular rotation (where the left side of the PPP meets the right side). Such  
11 minimization can be accomplished by slightly jittering the location of the extraction.

12 After the extraction, the PPP of the current frame needs to be time-aligned with the PPP extracted from the  
13 previous frame. Specifically, the current PPP is circularly shifted until it has the maximum cross-correlation  
14 with the previous PPP. The alignment process serves two purposes: (1) facilitates PPP quantization especially  
15 in low-bit-rate predictive quantization schemes (2) facilitates the construction of the whole frame of excitation  
16 in the synthesis procedure which will be discussed next.

17 The aligned PPPs are then quantized and transmitted to the decoder. To create a full-frame of excitation from  
18 the current and previous PPPs, we need to compute an instantaneous phase track which is designed carefully so  
19 as to achieve maximum time-synchrony with the original residual signal. For this purpose, a cubic phase track  
20 can be employed along with four boundary conditions: (1) the initial lag value, (2) the initial phase offset, (3)  
21 the final lag value and (4) the final phase offset. At low bit rates, the final phase offset can be computed by the  
22 RCELP pitch contour.

23 Having created the entire frame of quantized residual, the decoder concludes its operation with LPC synthesis  
24 filter and memory updates.

25 4.2.4.4 Amplitude Quantization

26 Figure 4.2.4.4-1 shows the block diagram of the amplitude quantizer used in EVRC-B.

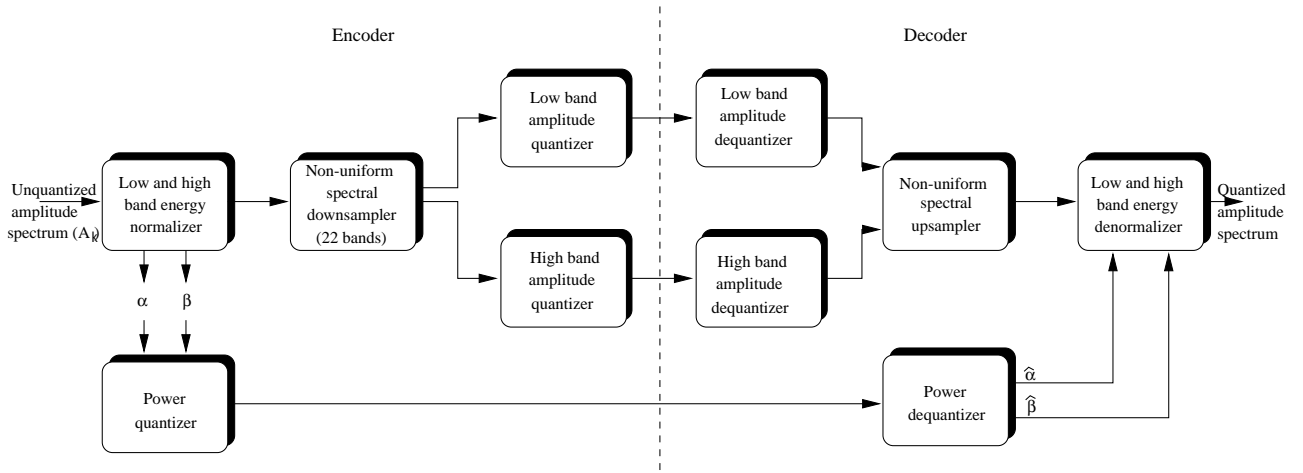

1

2

**Figure 4.2.4.4-1 A block diagram of amplitude quantization and dequantization modules**

3

4

5

6

As a first step, an amplitude spectrum is first normalized by two scaling factors at the encoder – one for the low band and one for the high band. The two resulting scaling factors are vector-quantized in the logarithmic domain and transmitted to the decoder. Next, the normalized spectrum is then non-uniformly downsampled to 22 spectral values according to the bin partition shown in Figure 4.2.4.4-2.

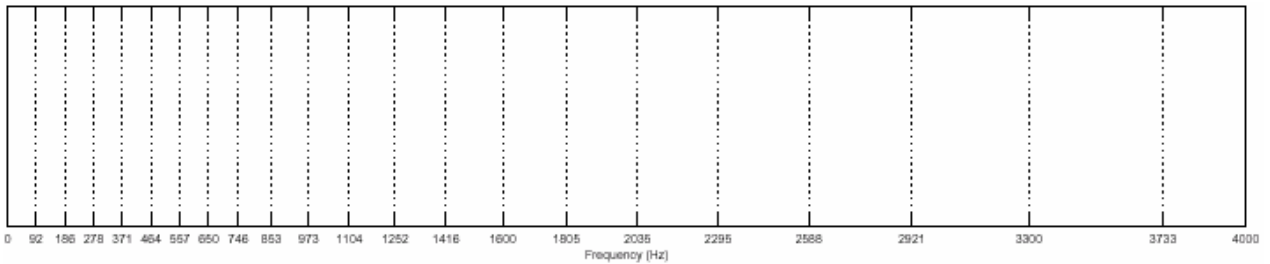

7

8

**Figure 4.2.4.4-2 An illustrative non-uniform band partition used PPP quantization**

9

10

11

Specifically, each harmonic is first associated with a bin. Then, an average magnitude of the harmonics falling in each bin is computed and hence, a vector of 22 values is produced. Figure 4.2.4.4-3 demonstrates an example of such non-uniform downsampling process.

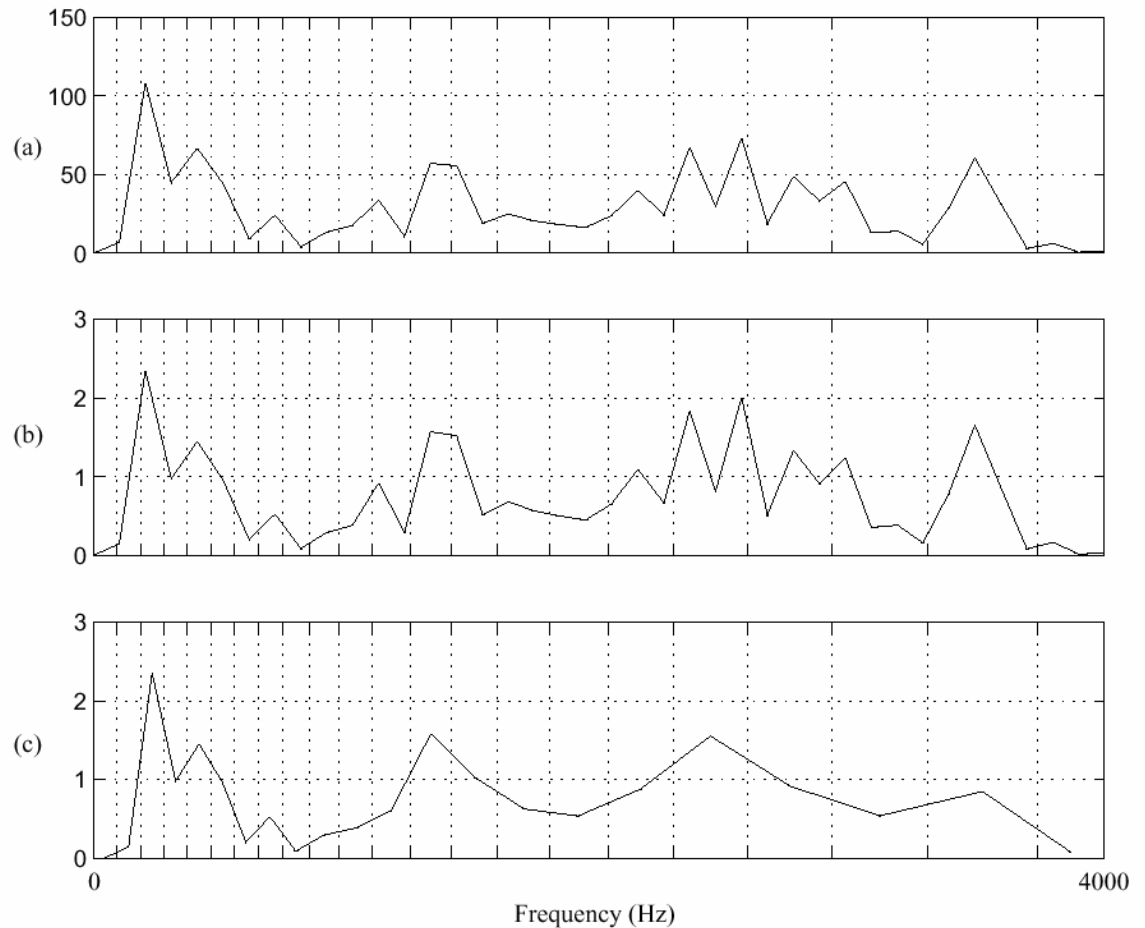

1  
2 **Figure 4.2.4.4-3 Illustration of the effect of spectral downsampling and upsampling**

3 The vertical grid lines are based on the non-uniform band partition shown in Figure 4.2.4.4-3 – (a): the original  
4 amplitude spectrum of a PPP; (b): the normalized version of the spectrum; and (c): the non-uniformly-  
5 downsampled version of the spectrum.

6 The significance of this downsampling/averaging process is to transform a variable dimension vector to a fixed  
7 dimension vector. It also takes advantage of the frequency-dependent frequency resolution of the human  
8 auditory system and removes perceptually irrelevant information existed in the spectra. Finally, the  
9 downsampled spectrum is split into two spectra (the low and high bands) and each of which is separately  
10 quantized. At the decoder, the low and the high band spectra are first reconstructed from the bit-stream  
11 transmitted from the encoder. The two spectra are then combined and sent to a non-uniform spectral upsampler.  
12 Afterwards, the scaling factors recovered from the bit-stream are used to denormalize the upsampled spectrum  
13 to reconstruct the quantized spectrum.

14 In QPPP, both the scaling factors and the spectra are quantized differentially whereas in FPPP, they are done so  
15 in a nondifferential manner.

#### 16 4.2.4.5 Phase Quantization

17 For QPPP, no bit is spent on phase quantization. The phase spectrum of the current PPP can be readily derived  
18 from combining the phase spectrum of the previous PPP and the contribution from the RCELP pitch contour.

- 1 For FPPP, we adopted a novel multi-band alignment approach to code phase spectrum. As demonstrated in  
 2 Figure 4.2.4.5-1, the effect of applying one linear phase-shift to a PPP is equivalent to its circular rotation in  
 3 time-domain.

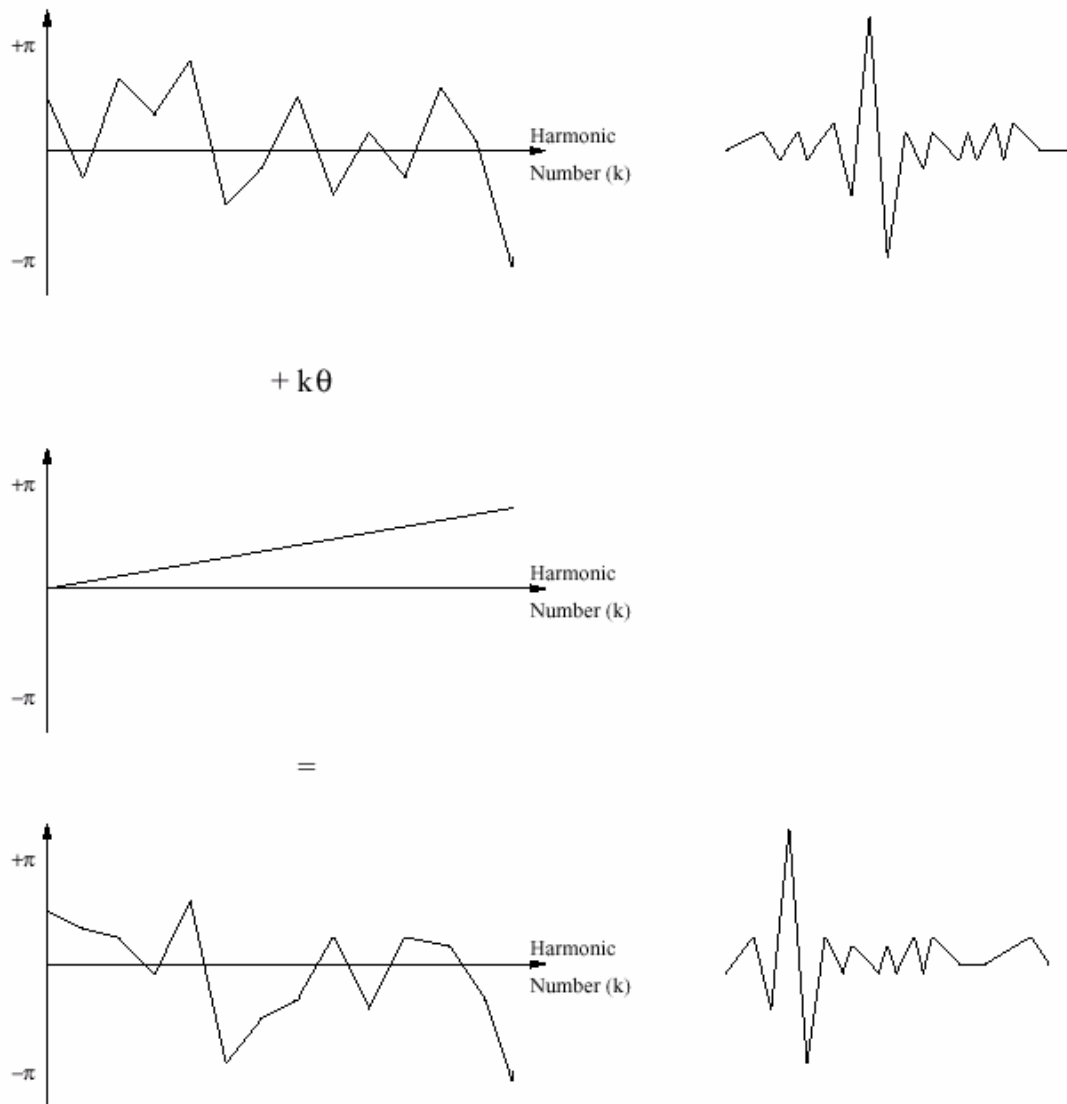

4

5 **Figure 4.2.4.5-1 Demonstration of the effect of a single-band alignment on a single PPP**

- 6 By extending the same idea to multiple sub-bands, one can begin controlling the “shape” details of a PPP by  
 7 applying different phase-shifts to different sub-bands. An example of which is illustrated in Figure 4.2.4.5-2 for  
 8 the case  $N=6$  (six sub-bands).

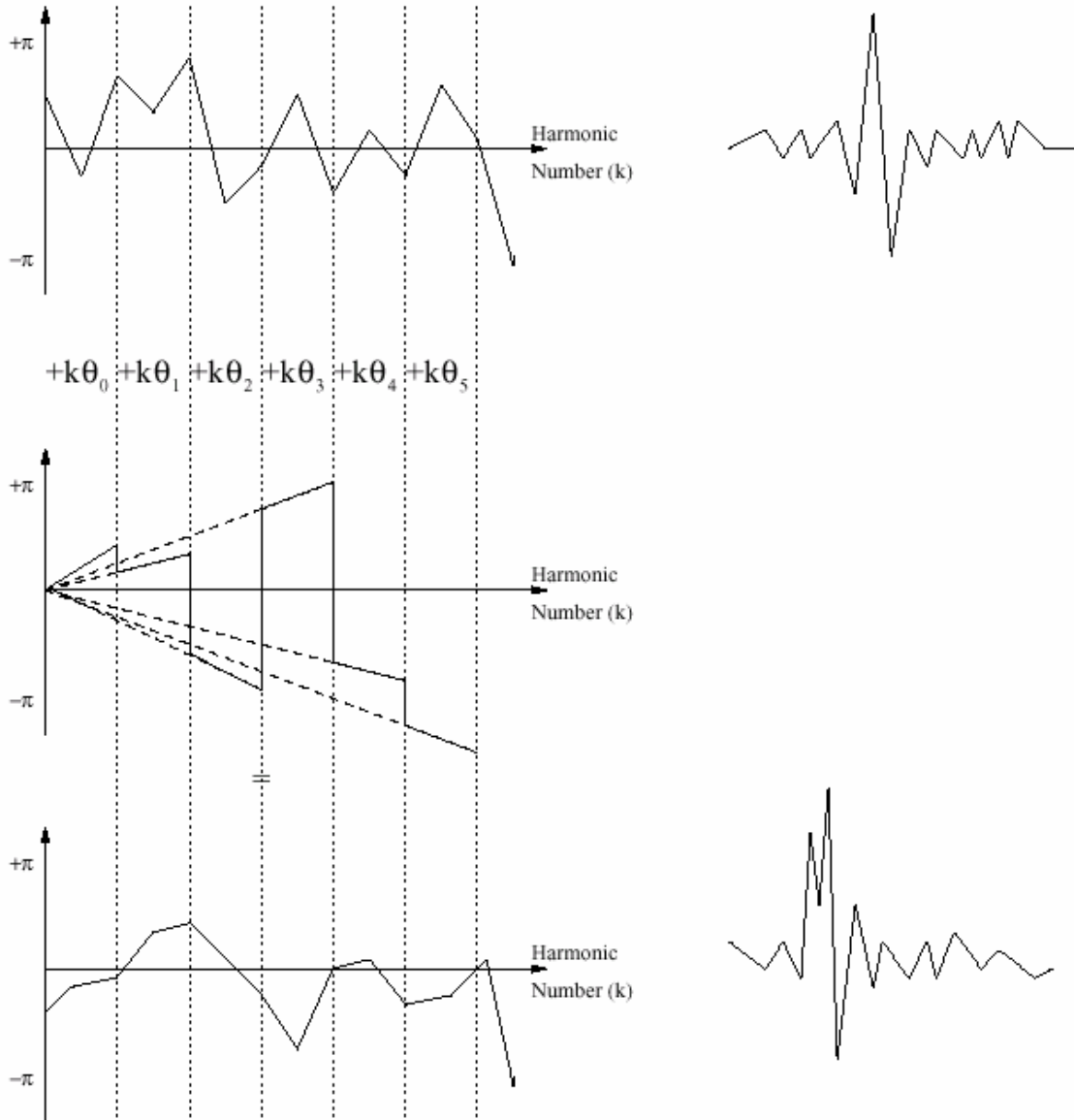

1  
2

**Figure 4.2.4.5-2 Demonstration of the effect of multi-band alignments on a single PPP**

3 Hence, the problem of phase quantization has been transformed into quantization of a series of linear phase  
 4 shifts. Similar to the conventional alignment process, the search of these linear-phase shifts can be performed in  
 5 the time-domain. The resulting linear-phase shifts are quantized in a scalar manner. The resolution and the  
 6 range of each phase shift are chosen such that it achieves the target bit rate.

7 **4.2.4.6 Special half-rate PPP frame**

8 The special half-rate PPP frame is used when a full-rate PPP frame is converted by a packet-level signaling  
 9 interworking function to a half-rate frame. The packet-level conversion is done by discarding the band  
 10 alignment bits in the full-rate, and repacking the remaining bits into a special half-rate frame. To indicate to the  
 11 EVRC-B decoder that it is a special half-rate PPP frame, the 7 lag bits of the HPPP frame are set to 0x6E—a  
 12 value that is never produced at the EVRC-B encoder.

#### 1 4.2.4.7 Detection of outliers

2 One peculiarity of the PPP scheme is the detection and treatment of unsuitable frames. If the shape/length of the  
 3 current PPP is deemed to change too much from the PPP of the previous frame (not enough periodicity), PPP is  
 4 abandoned in favor of FCELP. As briefly mentioned before, a separate closed-loop measure is also devised to  
 5 capture the outliers of the amplitude and phase quantizers in QPPP. When an outlier is detected in a particular  
 6 frame, the rate of that frame is then increased to full rate (FCELP or FPPP).

#### 7 4.2.5 Frame erasure handling

8 Whenever a frame is lost due to erasure, relevant parameters from the previous frame are used and a simple  
 9 frame repeat mechanism is performed on the lines of the previous frame's decoding mechanism.

#### 10 4.2.6 Bad rate/packet handling

11 If incorrect rate is received, checks which are always performed on certain parameters would fail and this  
 12 would be the detection of bad rate/packet and an erasure would be flagged and this packet would be treated as  
 13 lost and a frame erasure handling mechanism replaces the regular decoder.

### 14 4.3 Service Option 70

15 Traditional telephony systems use narrowband speech signals, with a frequency range of 300 Hz to 3400 Hz. A  
 16 significant improvement in perceived speech quality and intelligibility is obtained with wideband speech,  
 17 covering the larger frequency band of 50 Hz to 7 kHz. EVRC-WB or Service Option 70 leverages many of the  
 18 techniques used in EVRC-B and builds on it for coding wideband speech signal. Service Option 70 also  
 19 contains a generic audio coding mode that could be used for handling non-speech signals like music-on-hold,  
 20 and ringback tones. Service Option 70 also contains two operating points (see Table 2.5.1.2-1, SO 70 operating  
 21 points '100' and '111') that are interoperable with SO 68 operating points '000', and '111' respectively. In other  
 22 words, Service Option 70 supports a couple of operating points that use the exact same Full-rate CELP, Half-  
 23 rate CELP, and Eighth-rate CELP algorithm and bit-stream as those used by SO 68. The following figure  
 24 illustrates this design of EVRC-WB.

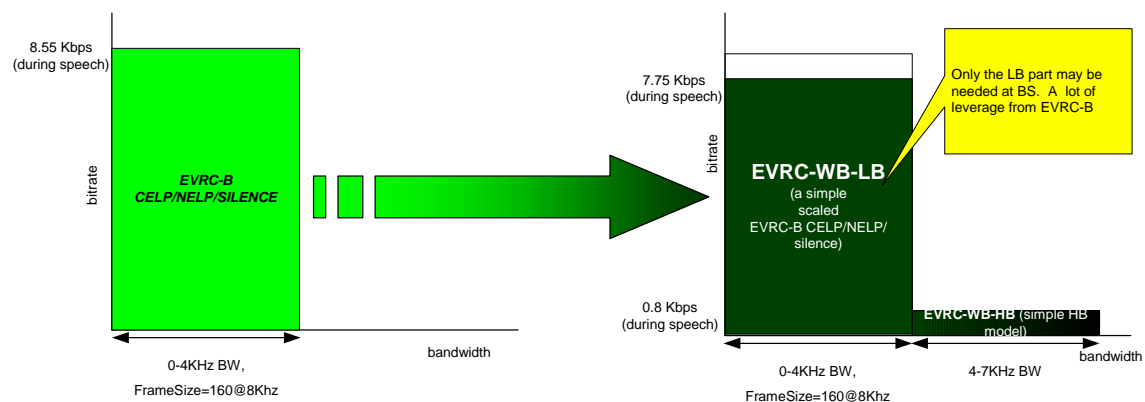

25

26

**Figure 4.3-1 EVRC-WB Conceptual Overview**

27 As shown in Figure 4.3-1, the EVRC-WB consists of two parts

28 a) A low-band coder, referred to in this document as EVRC-WB-LB, which is a slightly modified version of the  
 29 algorithms used in EVRC-B (i.e. SO 68.). This is an 8 KHz coder like the traditional coders (EVRC-A, EVRC-

1 B etc). Note: Only the lowband portion (EVRC-WB-LB) needs to be implemented if the input and output PCM  
2 are sampled at 8 KHz (for example at the Base-station for mobile-to-PSTN calls). Further more, when the  
3 encoder input PCM is sampled at 8 KHz, an SO 70 encoder could use Operating Points '100' and '111' (see  
4 Table 2.5.1.2-1) where the encoder can use the same Full-rate CELP, Half-rate CELP, and Eighth-rate  
5 algorithms and bitstreams used in SO 68 (interoperability/leverage between EVRC-WB and EVRC-B).

6 b) A high-band coder, referred to in this document as EVRC-WB-HB, for coding the higher-frequency band.

7 In the rest of the document,

- 8 o EVRC-WB-LB refers to the low-band parts of EVRC-WB
- 9 o EVRC-WB-HB refers to the high-band parts of EVRC-WB

10 EVRC-WB refers to a combination of LB and HB portions of EVRC-WB.

11 Figure 4.3-2 shows the wideband encoder. The input signal consists of wideband speech sampled at 16 kHz,  
12 which is inputted to a 50 Hz cutoff HPF followed by wideband noise suppression (WB NS) preprocessing  
13 modules. An analysis filterbank operates on the WB NS output to generate a lowband signal sampled at 8 kHz,  
14 and a high-band signal which is sampled at 7 kHz. This high-band signal represents the band from 3.5 to 7 kHz  
15 in the input signal, and the final reconstructed wideband signal will be limited in bandwidth to 7 kHz. Note that  
16 there is a 500 Hz overlap between the low and high bands, allowing for a more gradual transition between the  
17 bands.

18 The lowband signal is encoded using a modified version of the algorithms used in EVRC-B speech coder,  
19 which employs CELP and NELP coding schemes (Note: EVRC-B also uses PPP coding schemes) with a frame  
20 size of 20 milliseconds. Reusing the existing EVRC-B codec modules facilitates implementation and saves  
21 program and ROM storage. An additional advantage of the split-band coding described in this document is that  
22 it enables obtaining a coded narrowband-only signal without having to go through the steps of wideband  
23 decoding and narrowband encoding. More precisely, the narrowband bit stream is found by simply stripping the  
24 high-band side information portion off the wideband bit stream. This may be useful in scenarios where  
25 wideband playback is not possible outside of the knowledge of the encoder. For example, in the Base Station  
26 encoder when being used in the context of a mobile-to-land voice call where the PCM input/output is sampled  
27 at 8 KHz.

28  
29 Several signals from the lowband coder are used by the high-band analysis and synthesis; these are: (1) the  
30 excitation (i.e., quantized residual) signal from the lowband coder; (2) the quantized LPCs to give first  
31 reflection coefficient (as an indicator of the spectral tilt of the narrowband signal); (3) the quantized adaptive  
32 codebook gain; and (4) the quantized pitch lag.

33  
34 The high-band signal is pre-processed by a click-remover, which removes short energy bursts naturally  
35 occurring in speech. Unattenuated, these bursts interfere with the parametric high-band coder and cause  
36 artifacts in the reconstructed signal. The pre-processed high-band signal is then analyzed to obtain a parametric  
37 representation of the temporal and spectral envelopes. Next, a multiplexer (MUX) combines the coded  
38 parameter information with the lowband bit stream into a wideband bit stream, which is transmitted to the  
39 decoder.

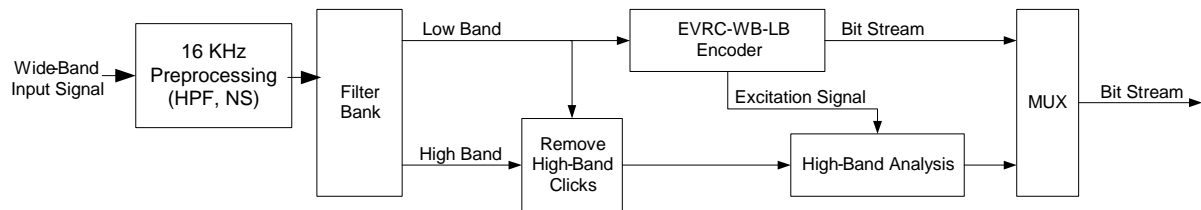

1  
2  
**Figure 4.3-2 Wideband Encoder**

3 The wideband decoder is shown in Figure 4.3-3. First, a demultiplexer (DEMUX) separates the bit stream into  
4 a lowband and a high-band part. The lowband decoder reconstructs the low-band signal, and passes on the  
5 excitation signal, first reflection coefficient, adaptive codebook gain and pitch lag to the high-band synthesis  
6 module. This module synthesizes the high-band signal using the side information from the encoder and the  
7 signals from the narrowband decoder. The low-band and high-band signals are combined in a synthesis filter  
8 bank, which outputs the reconstructed wideband speech signal, sampled at 16 kHz.

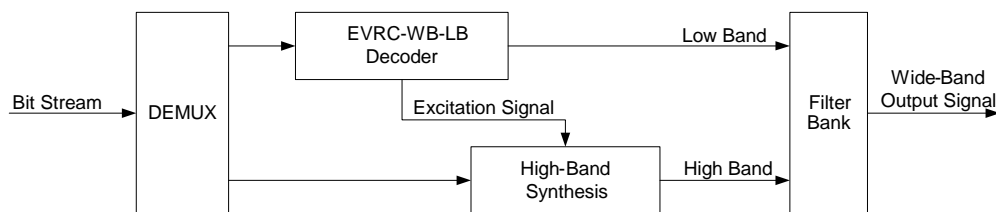

9  
10  
11  
**Figure 4.3-3 Wideband Decoder**

12  
13 A more detailed description of the high-band codec can be found in Section 4.3.3.

#### 14 15 4.3.1 Leverage FROM EVRC-B to obtain EVRC-WB-LB

16 Several changes were made to the EVRC-B codec to derive the lowband part of the wideband system. A  
17 summary of the most significant modifications is given as:

- 18  
19  
20  
21  
22  
23  
24  
25  
26  
27  
28  
29  
30  
31  
32
- Preprocessing (Noise Suppression and High-pass filter) operate on 16 KHz
  - Perceptual Weighting, including Harmonic Noise Weighting
  - The number of fixed codebook pulses per subframe has been reduced from 7 to 6 or 5 pulses.
  - Closed loop delay contour adjustment
  - ACB gain and FCB gains in CELP loop have joint optimization.
  - Pitch pre-processing of excitation in decoder
  - The delta lag (the difference between current and previous pitch lags, used after a frame erasure) is no longer transmitted.
  - The Prototype Pitch Period (PPP) coding mode is not used.
  - Noise Excited Linear Prediction (NELP) is used to send a payload at half rate, which includes the description for the high band. NELP uses the 28-bit LSPVQ (same as full-rate). There are also some minor filtering changes.
  - The original half-rate frame type (half-rate CELP) is used for Dim & Burst only.
  - Eighth-rate has new LSPVQ and Energy Quantization, but is very similar to that in EVRC-B

- Minor modifications to VAD and mode-decision

2  
3

#### 4.3.2 Bit Allocation

The tables below outline how payload bits are divided between lowband and high-band codec.

6  
7

**Table 4.3.2-1 Bit allocation**

Rate Set 1 (bits)	Low band	High band	Total
Full Rate	155	16	171
Half Rate	53	27	75
Eighth Rate	16		16

#### 4.3.3 Coding the High-Frequency Band Of Wideband Speech

##### 4.3.3.1 Click Remover

In wideband speech occasional bursts of energy (audible as clicks) occur in the upper part of the spectrum. These energy bursts are short in duration, typically just a few milliseconds, and span up to several kHz in frequency.

These clicks can have a negative impact on the high-band coding method, in two ways. Firstly, they cause the energy envelope over time to be much less smooth, introducing a sharp peak at the time of the energy burst. This means that either the time envelope needs to be modeled with high temporal resolution, increasing the amount of side information to the decoder, or that the energy burst will be smeared out over time during the reconstruction. A second problem with clicks is that they have a dominating influence on the spectral envelope, as modeled once per frame by the LP parameters. Consequently, the frame containing the click will be synthesized with a spectral envelope that is different from the preceding and following frames, which leads to a perceptually objectionable discontinuity.

Instead of trying to model and code these clicks, it is feasible to reduce these clicks in the input signal by means of a pre-processing, without noticeably degrading the quality of the uncoded signal. Subsequently coding the pre-processed signal avoids the aforementioned problems and produces fewer artifacts in the reconstructed signal.

The basic idea of the click-removing algorithm is to detect energy bursts that exist in the high band but not in the low band, and then briefly reduce the level of the high-band signal during each of these energy bursts. A detailed description follows below.

##### 4.3.3.2 High-Band Analysis

Figure 4.3.3.2-1 shows the high-band analysis algorithm. The most important module is the one that generates the high-band excitation signal, and is described in detail at the end of this section. The 7 kHz-sampled high-band input signal is analyzed to produce parameters that, together with signals from the narrowband decoder,

are used in the decoder to reconstruct the high band. The parameters represent the spectral and temporal envelope of the high band, and the ratio of harmonic to non-harmonic energy.

Six spectral parameters are obtained by a traditional linear prediction (LPC) analysis. For efficient coding, these prediction coefficients are converted to line spectral frequencies (LSFs) and quantized using a vector quantizer. The quantization index is transmitted to the decoder.

Five temporal gain parameters each represent the scale factor of a 4 millisecond subframe. The gain parameters are found by comparing the energies in each subframe of the input high-band signal with the unscaled, spectrally shaped high-band excitation signal. The gain parameters are also quantized with a vector quantizer, and the quantization index is transmitted to the decoder.

A multiplexer (MUX) combines the two quantization indices representing the spectral and temporal envelopes into a single bit stream. The total bit rate for the high band is 800 bits/second.

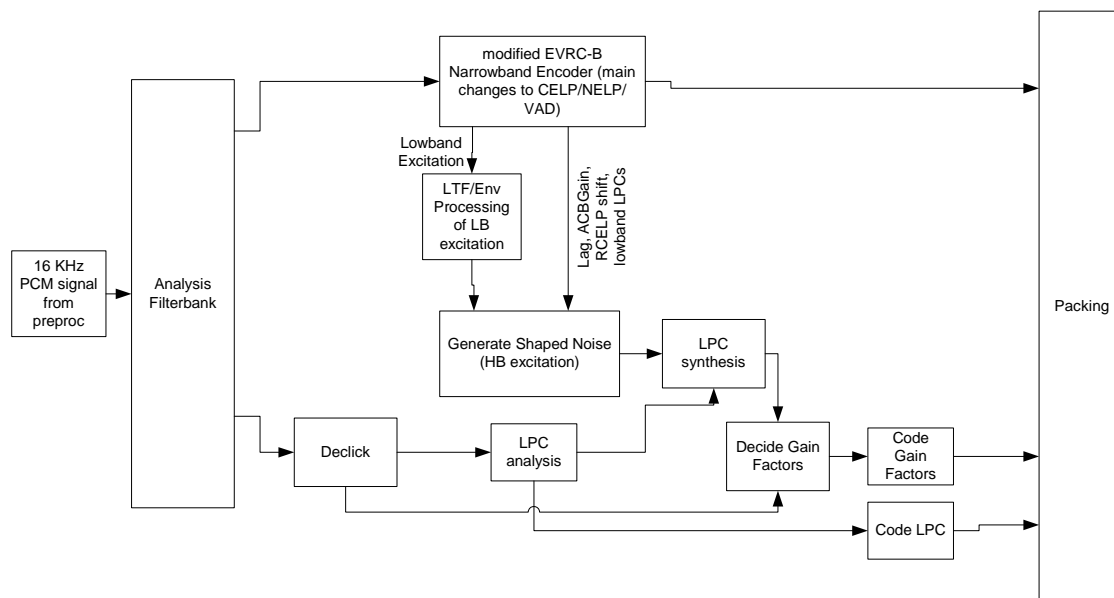

**Figure 4.3.3.2-1 High-band analysis**

#### 4.3.3.3 High-Band Excitation Generation

The high-band excitation signal is derived from the low-band excitation

Figure 4.3.3.3-1 depicts the process that generates the high-band excitation from the narrowband excitation signal. The excitation signal is first run through an all-pass filter of the form

This filter reduces the sparseness that results from encoding the low-band signal with a sparse codebook, and is intended to be used during unvoiced speech. The decision to use the output of the filter or the original input signal is derived from the quantized narrowband adaptive codebook gain and first reflection coefficient: unvoiced signals are characterized by a low adaptive codebook gain and a first reflection coefficient that is close to zero or positive (indicating a flat or upwards-tilted spectrum).

1  
2  
3  
4  
5  
6  
7  
8  
9  
10  
11  
12  
13  
14  
15  
16  
17  
18  
19  
20  
21  
22  
23  
24  
25

Next, a nonlinear function is applied to the above signal. This module up-samples the signal to 16 kHz, takes the absolute value. From here, a 7 kHz-sampled signal is produced using the same high-band analysis filter that was used to split the input signal in a low and a high band. The resulting signal is spectrally flattened with an adaptive 4<sup>th</sup> order linear prediction filter, to create the harmonically-extended excitation signal.

A modulated noise signal is generated by multiplying a unit-variance white noise signal with the envelope of the harmonically-extended excitation signal. This envelope is obtained by taking the squared value of each sample, smoothing with a first order IIR low-pass filter and taking the square-root of each smoothed sample.

The modulated noise and harmonically-extended excitation signals are now mixed together to create a signal with the right amount of harmonic and noise contents. The gains of the noise and harmonics parts are set adaptively to match the ratio of harmonic to noise energy in the high band of the original speech signal. Typically, the noise gain is between 0.1 and 0.7, and the harmonics gain is derived from the noise gain as  $G_{harm} = \sqrt{1 - G_{noise}^2}$ , so that the energy of the output signal is not affected by changing the gains.

Note that the high-band excitation is generated in both encoder and decoder. The encoder determines the side information for the gain factors by comparing the synthesized high band with the original high band, and the decoder then uses these gains to properly scale the synthesized high band. For the decoding process to be consistent with the encoding process, it is important that identical high-band excitations be generated in encoder and decoder. This is achieved by (1) using the *quantized* narrowband excitation, which is available to both encoder and decoder, and (2) having the same state for the random white noise generator in encoder and decoder at all times. The latter can be assured, for instance, by making the state of the random generator a deterministic function of information coded earlier within the same frame, such as the narrowband bit stream.

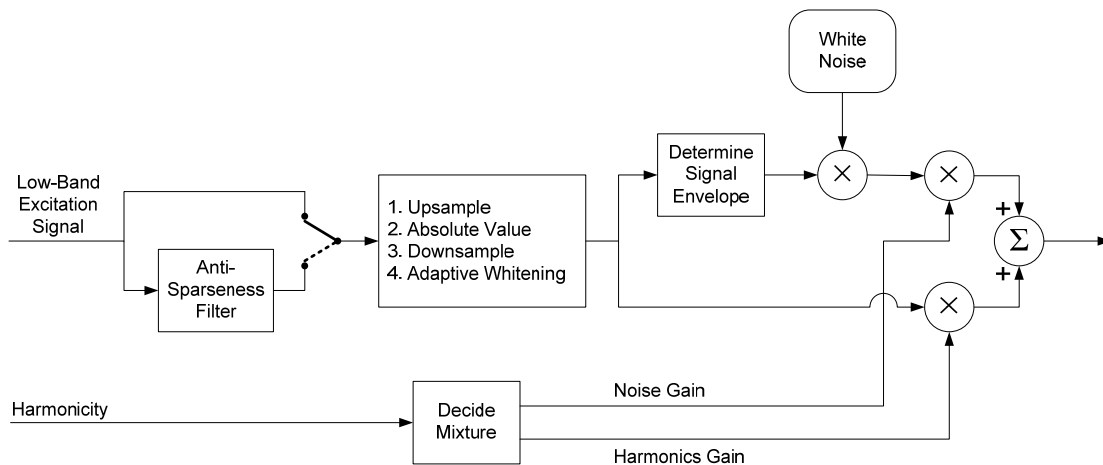

26  
27

**Figure 4.3.3.3-1 Generation of the high-band excitation signal**

#### 1 4.3.4 Silence Encoder

2 Silence frames are basically coded as narrowband and the upper band parameters are derived from the  
3 preceding NELP. Basically, you can think of using DTX in upperband as the model for silence coding.

#### 4 4.3.5 Decoder Details

5 Figure 4.3.5-1 shows the high-band decoder. It uses the side information transmitted from the encoder together  
6 with signals from the narrowband decoder to generate a high-band signal.

7

8 The high-band excitation signal is generated in the same way as in the encoder, using the decoded harmonicity  
9 parameter. Then, the excitation signal is spectrally shaped using the dequantized LPC coefficients. In the last  
10 step, the dequantized gain factors are used to scale each of the subframes, and the scaled subframes are  
11 combined in an overlap-add fashion to avoid discontinuities.

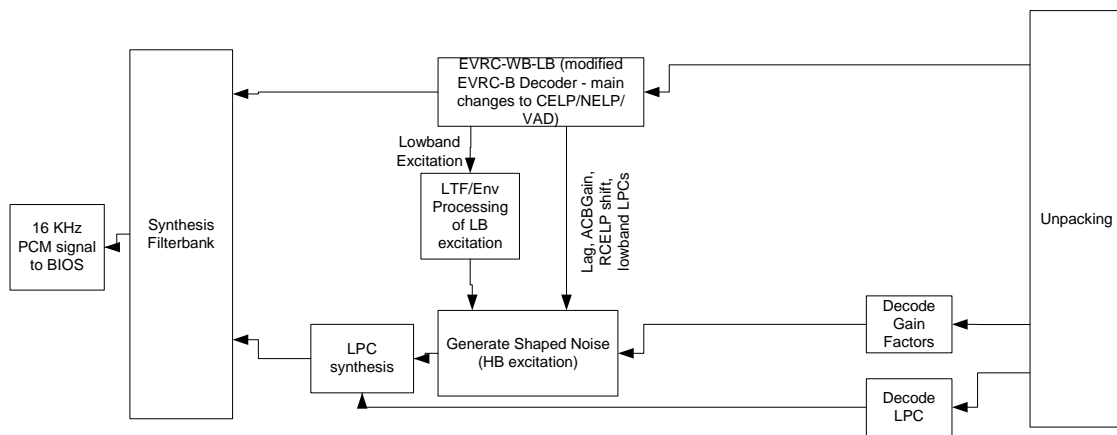

12

13

14

**Figure 4.3.5-1 High-band synthesis**

#### 15 4.4 Input Signal Preprocessing

16 Input preprocessing is needed to condition the input signal against excessive low frequency and other  
17 background noises that can degrade the codec voice quality. Refer to 1.1 for guidelines concerning potential  
18 variations of the Input Signal Preprocessing functions.

##### 19 4.4.1 Fast Automatic Gain Control for Wideband Inputs

20 For 16 kHz sampled inputs (SO 70 in WB mode), the input sampled speech shall be passed through a fast AGC  
21 as described below. The purpose of the AGC is to provide a soft clipping of high level input speech, such that  
22 the synthesized speech on the decoder side is less susceptible to the distortions associated with numeric  
23 saturation and hard clipping.

##### 24 **Inputs:**

- 25 • The input sampled speech signal,  $\{s(n)\}$ , ranging from -32768 to 32767

##### 26 **Outputs:**

### 3GPP2 C.S0014-C ver 1.0

- 1       • The AGC'ed speech signal which replaces the input speech,  $\{s(n)\} \leftarrow \{s_{agc}(n)\}$

2       **Initialization:**

- 3       • The filter memory is set to all zeros at initialization.
- 4       • The AGC factor:  $\gamma_{agc} = 1.0$
- 5       • The smoothed AGC factor:  $\tilde{\gamma}_{agc} = 1.0$

6       **Processing:**

7       First compute the peak and RMS values for the current frame of input speech:

8               
$$E_{peak} = 10 \log_{10} \left( \max \{s^2(n)\} \right); \quad 0 \leq n < 320, \quad (4.4.1-1)$$

9               
$$E_{rms} = 10 \log_{10} \left( \frac{1}{320} \sum_{i=0}^{319} s^2(n) \right). \quad (4.4.1-2)$$

10       Then calculate the coarse AGC factor as:

11               if ( $E_{peak} > 87$  and  $E_{rms} > 82$ ) {

12                        $\gamma_{agc} = 0.707$

13               } else {

14                        $\gamma_{agc} = \min \{1.0, 1.1 \times \gamma_{agc}\}$

15               }

16       and finally smooth and apply the AGC factor to the input speech:

17               for ( $i = 0; i < 320; i++$ ) {

18                        $\tilde{\gamma}_{agc} = 0.999\tilde{\gamma}_{agc} + 0.001\gamma_{agc}$

19                        $s(i) = \tilde{\gamma}_{agc}s(i)$

20               }

#### 21       4.4.2 High-Pass Filter

22       The input sampled speech shall be high-pass filtered as described below:

23       **Inputs:**

- 24       • The input sampled speech signal,  $\{s(n)\}$

25       **Outputs:**

- 26       • The high-pass filtered speech signal,  $\{s_{hp}(n)\}$

27       **Initialization:**

- 28       • The filter memory is set to all zeros at initialization.

29       **Processing:**

30       The High-Pass Filter for Service Option 3 is a sixth order Butterworth filter implemented as three cascaded

31       biquadratic sections. The cutoff frequency of the filter is 120 Hz. The transfer function of the filter is:

$$H_{hpf} = \prod_{j=1}^3 H_j(z) \quad (4.4.2-1)$$

where each section,  $H_j(z)$ , is given by:

$$H_j(z) = \frac{a_{j0} + a_{j1}z^{-1} + a_{j2}z^{-2}}{1 + b_{j1}z^{-1} + b_{j2}z^{-2}}. \quad (4.4.2-2)$$

The filter coefficients are given as:

$$\begin{aligned} a_{10} &= 1.0, & a_{11} &= -2.000125721, & a_{12} &= 1.000125737, \\ b_{11} &= -1.943779252, & b_{12} &= 0.952444269, \\ a_{20} &= 1.0, & a_{21} &= -1.999873569, & a_{22} &= 0.999873585, \\ b_{21} &= -1.866892280, & b_{22} &= 0.875214548, \\ a_{30} &= 0.833469450, & a_{31} &= -1.666939491, & a_{32} &= 0.833470028, \\ b_{31} &= -1.825209384, & b_{32} &= 0.833345838. \end{aligned}$$

The High-Pass Filter for SO 68 and SO 70 with 8 kHz sampled inputs is a fourth order filter. The cutoff frequency of the filter is 80 Hz. The transfer function of the filter is:

$$H_{hpf} = \frac{\left( (0.9329833984375) + (-2.7984619140625)z^{-1} + (2.7984619140625)z^{-2} \right) + (-0.9329833984375)z^{-3}}{\left( 1 + (2.86181640625)z^{-1} + (-2.7315673828125)z^{-2} \right) + (0.869384765625)z^{-3}} \quad (4.4.2-3)$$

The High-Pass Filter for use with 16 kHz input to SO 70 is a fourth order filter. The cutoff frequency of the filter is 50 Hz. The transfer function of the filter is:

$$H_{hpf}(z) = \frac{\sum_{i=0}^4 b_i z^{-i}}{\sum_{i=0}^4 a_i z^{-i}}, \quad (4.4.2-4)$$

where the 32 bit quantified filter coefficients are given as:

$$\begin{aligned} \mathbf{b} &= \{ 0.966807253658771514892578125, & -3.8671675957739353179931640625, \\ & 5.800720684230327606201171875, & -3.8671675957739353179931640625, \\ & 0.966807253658771514892578125 \} \\ \mathbf{a} &= \{ 1.0, & -3.955420531332492828369140625, \\ & 5.8673752509057521820068359375, & -3.8684739582240581512451171875, \\ & 0.9565193988382816314697265625 \} \end{aligned}$$

#### 4.4.3 Noise Suppression

Noise Suppression is used to improve the signal quality that is presented to the Model Parameter Estimator. The procedures by which the Noise Suppression shall be implemented are described in this section. SO 70 with 16 kHz sampled input uses a wideband Noise Suppression algorithm, which is described below in the context

### 3GPP2 C.S0014-C ver 1.0

1 of “Wideband NS”, or “WB NS”. When using SO 70 in narrowband mode (i.e., 8kHz sampled inputs), the  
2 SO 3/SO 68 Noise Suppression (or “NB NS”) algorithm shall be used.

#### 3 **Input:**

- 4 • The output of the High-Pass Filter,  $\{s_{hp}(n)\}$
- 5 • The open-loop long-term prediction gain from the previous frame  $\beta$  (WB NS only).

#### 6 **Output:**

- 7 • The primary signal output of the Noise Suppressor is designated as  $\{s'(n)\}$
- 8 • The zero-delay auxiliary output for use in signal analysis  $\{s_{aux}(n)\}$  (WB NS only)
- 9 • The SNR band estimates for 0-2 kHz and 2-4 kHz bands,  $curr\_ns\_snr[0]$  and  $curr\_ns\_snr[1]$ ,  
10 respectively

#### 11 **Initialization:**

12 The following variables shall be set to zero at initialization (frame  $m = 0$ ):

- 13 • The overlapped portion of the input frame buffer,  $\{d(m)\}$
- 14 • The pre-emphasis and de-emphasis memories
- 15 • The overlap-and-add buffer,  $h(n)$
- 16 • The output buffer history,  $s'(n)$ ;  $0 \leq n < 160$

17 The following shall be initialized to a startup value other than zero:

- 18 • The channel energy estimate,  $E_{ch}(m)$ , (see 4.4.3.2)
- 19 • The long-term power spectral estimate,  $\overline{E}_{dB}(m)$ , (see 4.4.3.6)
- 20 • The channel noise estimate,  $E_n(m)$ , (see 4.4.3.13)

21 **Processing:** Although the frame size of the speech codec is 20 ms, the Noise Suppressor frame size is 10 ms.  
22 Therefore, the following procedures shall be executed two times per 20 ms speech frame and the current 10 ms  
23 frame shall be denoted  $m$ . Figure 4.4.3-1 depicts the Noise Suppression system that is described in the  
24 following sections. The signals/blocks added for use with WB NS are designated by dashed lines.

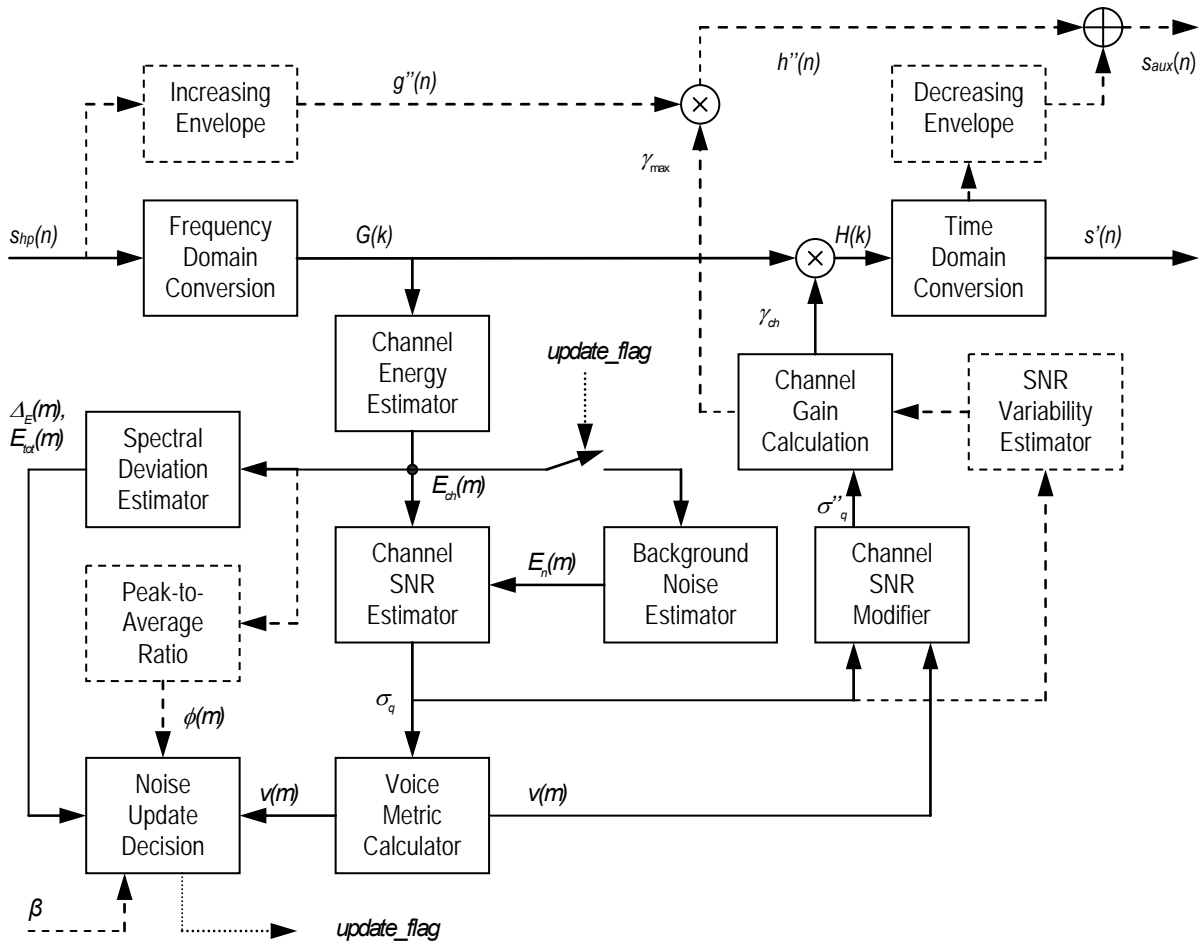

Figure 4.4.3-1 Noise Suppression Block Diagram

4.4.3.1 Frequency Domain Conversion

The input signal is windowed using a smoothed trapezoid window, in which the first  $D$  samples of the input frame buffer  $\{d(m)\}$  are overlapped from the last  $D$  samples of the previous frame. This overlap is described as:

$$d(m, n) = d(m-1, L+n); \quad 0 \leq n < D, \quad (4.4.3-1)$$

where  $m$  is the current frame,  $n$  is the sample index to the buffer  $\{d(m)\}$ ,  $L = 80$  is the frame length, and  $D = 24$  is the overlap (or delay) in samples. For WB NS,  $L = 160$ , and  $D = 160$ .

The remaining samples of the input buffer are then pre-emphasized according to the following:

$$d(m, D+n) = s_{hp}(n) + \zeta_p s_{hp}(n-1); \quad 0 \leq n < L, \quad (4.4.3-2)$$

where  $\zeta_p = -0.8$  is the pre-emphasis factor. This results in the input buffer containing  $L + D = 104$  samples in which the first  $D$  samples are the pre-emphasized overlap from the previous frame, and the following  $L$  samples are pre-emphasized input from the current frame. For WB NS,  $L + D = 320$  samples.

1 Next, a smoothed trapezoidal window is applied to the input buffer to form the DFT data buffer,  $\{g(n)\}$ ,  
 2 defined as:

$$3 \quad g(n) = \begin{cases} d(m,n) \sin^2(\pi(n+0.5)/2D) & ; 0 \leq n < D, \\ d(m,n) & ; D \leq n < L, \\ d(m,n) \sin^2(\pi(n-L+D+0.5)/2D) & ; L \leq n < D+L, \\ 0 & ; D+L \leq n < M, \end{cases} \quad (4.4.3-3)$$

4 where  $M = 128$  is the DFT sequence length and all other terms are previously defined. For WB\_NS, the  
 5 window is a sine window, and the signal  $\{g(n)\}$  is defined as:

$$6 \quad g(n) = \begin{cases} d(m,n) \sin(\pi(n+0.5)/(D+L)) & ; 0 \leq n < D+L \\ 0 & ; D+L \leq n < M \end{cases}, \quad (4.4.3-4)$$

7 where  $M = 512$  is the DFT sequence length.

8 The transformation of  $g(n)$  to the frequency domain is performed using the Discrete Fourier Transform (DFT)  
 9 defined<sup>†</sup> as:

$$10 \quad G(k) = \frac{2}{M} \sum_{n=0}^{M-1} g(n) e^{-j2\pi nk/M}; \quad 0 \leq k < M, \quad (4.4.3-5)$$

11 where  $e^{j\omega}$  is a unit amplitude complex phasor with instantaneous radial position  $\omega$ .

#### 12 4.4.3.2 Channel Energy Estimator

13 Calculate the channel energy estimate  $E_{ch}(m)$  for the current frame,  $m$ , as:

$$14 \quad E_{ch}(m,i) = \max \left\{ E_{\min}, \alpha_{ch}(m) E_{ch}(m-1,i) + (1 - \alpha_{ch}(m)) \frac{1}{f_H(i) - f_L(i) + 1} \sum_{k=f_L(i)}^{f_H(i)} |G(k)|^2 \right\}; \quad 0 \leq i < N_c, \quad (4.4.3-6)$$

15 where  $E_{\min} = 0.0625$  is the minimum allowable channel energy,  $\alpha_{ch}(m)$  is the channel energy smoothing factor  
 16 (defined below),  $N_c = 16$  ( $N_c = 61$  for WB NS) is the number of combined channels, and  $f_L(i)$  and  $f_H(i)$  are the  $i$ -  
 17 th elements of the respective low and high channel combining tables, which are defined for  $N_c = 16$  as:

$$18 \quad f_L = \{ 2, 4, 6, 8, 10, 12, 14, 17, 20, 23, 27, 31, 36, 42, 49, 56 \},$$

$$19 \quad f_H = \{ 3, 5, 7, 9, 11, 13, 16, 19, 22, 26, 30, 35, 41, 48, 55, 63 \},$$

---

<sup>†</sup> This atypical definition is used to exploit the efficiencies of the complex Fast Fourier Transform (FFT). The  $2/M$  scale factor results from preconditioning the  $M$  point real sequence to form an  $M/2$  point complex sequence that is transformed using an  $M/2$  point complex FFT. Details on this technique can be found in Proakis, J. G. and Manolakis, D. G., *Introduction to Digital Signal Processing*, New York, Macmillan, 1988, pp. 721-722.

1 and defined for  $N_c = 61$  as:

2  $f_L = \{ 1, 2, 3, 4, 5, 6, 7, 9, 11, 13, 15, 17, 19, 21, 23, 25, 27, 29, 31, 33, 35, 37, 39, 41, 43, 45,$   
 3  $47, 49, 51, 53, 55, 57, 59, 62, 65, 68, 71, 74, 77, 80, 84, 88, 92, 96, 100, 105, 110, 115, 121,$   
 4  $127, 133, 141, 149, 157, 166, 176, 186, 197, 209, 221, 235 \},$

5  $f_H = \{ 1, 2, 3, 4, 5, 6, 8, 10, 12, 14, 16, 18, 20, 22, 24, 26, 28, 30, 32, 34, 36, 38, 40, 42, 44,$   
 6  $46, 48, 50, 52, 54, 56, 58, 61, 64, 67, 70, 73, 76, 79, 83, 87, 91, 95, 99, 104, 109, 114, 120,$   
 7  $126, 132, 140, 148, 156, 165, 175, 185, 196, 208, 220, 234, 248 \},$

8 The channel energy smoothing factor,  $\alpha_{ch}(m)$ , is defined as:

$$9 \quad \alpha_{ch}(m) = \begin{cases} 0.00 & ; m \leq 1 \\ 0.45 & ; m > 1 \text{ and NB NS} \\ 0.40 & ; m > 1 \text{ and WB NS} \end{cases} \quad (4.4.3-7)$$

10 So, this means that  $\alpha_{ch}(m)$  assumes a value of zero for the first frame ( $m = 1$ ) and a value of 0.45 for all  
 11 subsequent frames of NB NS, and 0.40 for WB NS. This allows the channel energy estimate to be initialized to  
 12 the unfiltered channel energy of the first frame.

#### 13 4.4.3.3 Channel SNR Estimator

14 Estimate the quantized channel SNR indices as:

$$15 \quad \sigma_q(i) = \max \left\{ 0, \min \left\{ 89, \text{round} \left\{ 10 \log_{10} \left( \frac{E_{ch}(m,i)}{E_n(m,i)} \right) / 0.375 \right\} \right\} \right\}; \quad 0 \leq i < N_c, \quad (4.4.3-8)$$

16 where  $E_n(m)$  is the current channel noise energy estimate (see 4.4.3.13), and the values of  $\{ \sigma_q \}$  are constrained  
 17 to be between 0 and 89, inclusive. In addition, the WB NS requires the unquantized SNR values, expressed by:

$$18 \quad \sigma_{unq}(i) = 10 \log_{10} \left( \frac{E_{ch}(m,i)}{E_n(m,i)} \right); \quad 0 \leq i < N_c, \quad (4.4.3-9)$$

19 which can be saved as an intermediate step in Equation 4.4.3-8 with no computational overhead.

#### 20 4.4.3.4 Voice Metric Calculation

21 Next, calculate the sum of voice metrics as:

$$22 \quad v(m) = \sum_{i=0}^{N_c-1} V(\sigma_q(i)), \quad (4.4.3-10)$$

23 where  $V(k)$  is the  $k^{\text{th}}$  value of the 90 element voice metric table  $\mathbf{V}$ , that is defined as:

24  $\mathbf{V} = \{ 2, 2, 2, 2, 2, 2, 2, 2, 2, 2, 2, 2, 3, 3, 3, 3, 3, 4, 4, 4, 5, 5, 5, 6, 6, 7, 7, 7, 8, 8, 9, 9, 10, 10,$   
 25  $11, 12, 12, 13, 13, 14, 15, 15, 16, 17, 17, 18, 19, 20, 20, 21, 22, 23, 24, 24, 25, 26, 27, 28, 28,$

1 29, 30, 31, 32, 33, 34, 35, 36, 37, 37, 38, 39, 40, 41, 42, 43, 44, 45, 46, 47, 48, 49, 50, 50, 50,  
 2 50, 50, 50, 50, 50, 50, 50 }.

3 4.4.3.5 Band SNRs for Rate Determination Algorithm

4 The SNR estimates  $\text{curr\_ns\_snr}[0]$  and  $\text{curr\_ns\_snr}[1]$  are required for the Speech Mode Decision Algorithm in  
 5 4.8.3 for SO 68 and SO 70. These estimates are given as:

$$6 \quad \text{curr\_ns\_snr}[0] = 10 \log_{10} \left( \frac{\sum_{i=0}^{K_1-1} E_{ch}(m, i)}{\sum_{i=0}^{K_1-1} E_n(m, i)} \right), \quad (4.4.3-11)$$

7 and

$$8 \quad \text{curr\_ns\_snr}[1] = 10 \log_{10} \left( \frac{\sum_{i=K_1}^{K_2-1} E_{ch}(m, i)}{\sum_{i=K_1}^{K_2-1} E_n(m, i)} \right), \quad (4.4.3-12)$$

9 where  $K_1 = 11$ ,  $K_2 = N_c$  for NB NS, and  $K_1 = 33$ ,  $K_2 = 50$  for WB NS.

10 4.4.3.6 Spectral Deviation Estimator

11 Calculate the estimated log power spectrum as:

$$12 \quad E_{dB}(m, i) = 10 \log_{10} (E_{ch}(m, i)) \quad ; \quad 0 \leq i < N_c . \quad (4.4.3-13)$$

13 Then, calculate the estimated spectral deviation between the current power spectrum and the average long-term  
 14 power spectral estimate:

$$15 \quad \Delta_E(m) = \sum_{i=0}^{N_c-1} |E_{dB}(m, i) - \bar{E}_{dB}(m, i)|, \quad (4.4.3-14)$$

16 where  $\bar{E}_{dB}(m)$  is the average long-term power spectral estimate calculated during the previous frame, as  
 17 defined in Equation 4.4.3-19. The initial value of  $\bar{E}_{dB}(m)$ , however, is defined to be the estimated log power  
 18 spectrum of frame 1, or:

$$19 \quad \bar{E}_{dB}(m) = E_{dB}(m); \quad m=1. \quad (4.4.3-15)$$

20 Calculate the total channel energy estimate,  $E_{tot}(m)$ , for the current frame,  $m$ , according to the following:

$$21 \quad E_{tot}(m) = 10 \log_{10} \left( \sum_{i=0}^{N_c-1} E_{ch}(m, i) \right). \quad (4.4.3-16)$$

22 Calculate the exponential windowing factor,  $\alpha(m)$ , as a function of total channel energy,  $E_{tot}(m)$ , as:

$$\alpha(m) = \alpha_H - \left( \frac{\alpha_H - \alpha_L}{E_H - E_L} \right) (E_H - E_{tot}(m)), \quad (4.4.3-17)$$

and then limit the result to be between  $\alpha_H$  and  $\alpha_L$  by

$$\alpha(m) = \max \{ \alpha_L, \min \{ \alpha_H, \alpha(m) \} \}, \quad (4.4.3-18)$$

where  $E_H$  and  $E_L$  are the energy endpoints (in dB) for the linear interpolation of  $E_{tot}(m)$ , that is transformed to  $\alpha(m)$  which has the limits  $\alpha_L \leq \alpha(m) \leq \alpha_H$ . The values of these constants are defined as:  $E_H = 50$ ,  $E_L = 30$ ,  $\alpha_H = 0.99$ ,  $\alpha_L = 0.50$ . As an example, a signal with relative energy of 40 dB would use an exponential windowing factor of  $\alpha(m) = 0.745$  for the following calculation.

Update the average long-term power spectral estimate for the next frame by:

$$\bar{E}_{dB}(m+1, i) = \alpha(m) \bar{E}_{dB}(m, i) + (1 - \alpha(m)) E_{dB}(m, i); \quad 0 \leq i < N_c, \quad (4.4.3-19)$$

where all the variables are previously defined.

#### 4.4.3.7 Peak-to-Average Ratio

For the WB NS only, the Peak-to-Average Ratio calculation is used to detect tonal input signals above 220 Hz, and then inhibit the update of the background noise estimate to avoid attenuating these types of inputs. The Peak-to-Average ratio is given as:

$$\phi(m) = 10 \log_{10} (\max \{ E_{ch}(m, i) \}) - E_{tot}; \quad 6 \leq i < N_c, \quad (4.4.3-20)$$

#### 4.4.3.8 Background Noise Update Decision

The following logic, as shown in pseudo-code, demonstrates how the noise estimate update decision is ultimately made:

```

19  /* Normal update logic */
20  update_flag = FALSE
21  if ( v(m) ≤ UPDATE_THLD ) {
22      update_flag = TRUE
23      update_cnt = 0
24  }
25  /* Forced update logic */
26  else if (( E_tot(m) > NOISE_FLOOR_DB ) and ( Δ_E(m) < DEV_THLD )) {
27      if (WB_NS) {
28          /* Increment update_cnt only if low long-term prediction gain and no sine waves */
29          if (β < 0.4 and φ(m) < 10)
30              update_cnt = update_cnt + 1
31      } else
32          update_cnt = update_cnt + 1
33      if ( update_cnt ≥ UPDATE_CNT_THLD )

```

3GPP2 C.S0014-C ver 1.0

```

1      update_flag = TRUE
2  }
3  /* "Hysteresis" logic to prevent long-term creeping of update_cnt */
4  if ( update_cnt == last_update_cnt )
5      hyster_cnt = hyster_cnt + 1
6  else
7      hyster_cnt = 0
8      last_update_cnt = update_cnt
9  if ( hyster_cnt > HYSTER_CNT_THLD )
10     update_cnt = 0

```

11 The values of the previously used constants are UPDATE\_THLD = 35, NOISE\_FLOOR\_DB =  $10\log_{10}(E_{floor})$   
12 (see 4.1.2.8), DEV\_THLD =  $28N_c/16$ , UPDATE\_CNT\_THLD = 50, HYSTER\_CNT\_THLD = 6.

13 4.4.3.9 SNR Estimate Modification

14 Next, determine whether the channel SNR modification should take place, then proceed to modify the  
15 appropriate SNR indices:

```

16     /* Set or reset modify flag */
17     index_cnt = 0
18     for ( i = N_M to N_c - 1 step 1 ) {
19         if (  $\sigma_q(i) \geq$  INDEX_THLD )
20             index_cnt = index_cnt + 1
21     }
22     if ( index_cnt < INDEX_CNT_THLD )
23         modify_flag = TRUE
24     else
25         modify_flag = FALSE
26
27     /* Modify the SNR indices to get  $\{\sigma'_q\}$  */
28     if ( modify_flag == TRUE )
29         for ( i = 0 to N_c - 1 step 1 )
30             if ( (  $v(m) \leq$  METRIC_THLD ) or (  $\sigma_q(i) \leq$  SETBACK_THLD ) )
31                  $\sigma'_q(i) = 1$ 
32             else
33                  $\sigma'_q(i) = \sigma_q(i)$ 
34     else
35          $\{\sigma'_q\} = \{\sigma_q\}$ 
36
37     /* Limit  $\{\sigma''_q(i)\}$  to SNR threshold  $\sigma_{th}$  */
38     for ( i = 0 to N_c - 1 step 1 )
39         if (  $\sigma'_q(i) < \sigma_{th}$  )
40              $\sigma''_q(i) = \sigma_{th}$ 

```

$$\sigma_q''(i) = \sigma_q'(i)$$

For NB NS, the previous constants and thresholds are given to be:  $N_M = 5$ , INDEX\_THLD = 12, INDEX\_CNT\_THLD = 5, METRIC\_THLD = 45, SETBACK\_THLD = 12,  $\sigma_{th} = 6$ . For WB NS, these are given as:  $N_M = 12$ , INDEX\_THLD = 12, INDEX\_CNT\_THLD = 20, METRIC\_THLD = 172, SETBACK\_THLD = 12,  $\sigma_{th} = 6$ .

#### 4.4.3.10 SNR Variability Estimator

For WB NS only, the SNR Variability Estimator works in conjunction with the Channel Gain Computation block to increase the SNR gain threshold for non-stationary background noises such as "office babble" and some kinds of street noise. The first step in this process is to estimate the instantaneous average channel SNR from the unquantized channel SNRs:

$$SNR_{inst} = \frac{1}{N_c - 5} \sum_{i=5}^{N_c-1} \sigma_{unq}(i). \quad (4.4.3-21)$$

Then, the negative SNR variability is computed based on negative values of the instantaneous SNR. It is presumed that a negative SNR can only occur as a result of fluctuating background noise, and not from the presence of voice. Therefore, the SNR threshold bias factor  $\sigma_{bias}$  is derived by calculating the negative SNR variability  $\psi(m)$  as:

$$\psi(m) = \begin{cases} 0.99\psi(m-1) + 0.01SNR_{inst}^2 & ; SNR_{inst} < 0 \\ \psi(m-1) & ; otherwise \end{cases}. \quad (4.4.3-22)$$

The variability factor is initially set to 0.375 when the frame count is less than or equal to four ( $m \leq 4$ ). The SNR threshold bias factor  $\sigma_{bias}$  is then calculated as:

$$\sigma_{bias} = \min\{40(\psi(m) - 0.75), 16\}. \quad (4.4.3-23)$$

#### 4.4.3.11 Channel Gain Computation

Compute the overall gain factor for the current frame as:

$$\gamma_n = \max \left\{ \gamma_{\min}, -10 \log_{10} \left\{ \frac{1}{E_{floor}} \sum_{i=0}^{N_c-1} E_n(m, i) \right\} \right\}, \quad (4.4.3-24)$$

where  $\gamma_{\min} = -13$  is the minimum overall gain,  $E_{floor} = 1$  is the noise floor energy, and  $E_n(m)$  is the estimated noise spectrum (see 4.4.3.13) calculated during the previous frame.

Next, calculate channel gains (in dB) as:

$$\gamma_{dB}(i) = \mu_g (\sigma_q''(i) - \sigma_{th}) + \gamma_n; \quad 0 \leq i < N_c, \quad (4.4.3-25)$$

where  $\mu_g$  is the gain slope, and  $\sigma_{th}$  is the SNR gain threshold. For NB NS,  $\sigma_{th} = 6$  and  $\mu_g = 0.39$ , and for WB NS,  $\mu_g = 0.50$  and the value of the SNR gain threshold is based on the SNR variability estimate as:

$$\sigma_{th} = 6 + \sigma_{bias} . \quad (4.4.3-26)$$

Then convert to linear channel gains using the following expression:

$$\gamma_{ch}(i) = \min \left\{ 1, 10^{\gamma_{dB}(i)/20} \right\}; \quad 0 \leq i < N_c, \quad (4.4.3-27)$$

#### 4.4.3.12 Frequency Domain Filtering

Now, apply the channel gains to the transformed input signal  $G(k)$ :

$$H(k) = \begin{cases} \gamma_{ch}(i)G(k) & ; f_L(i) \leq k \leq f_H(i), 0 \leq i < N_c, \\ G(k) & ; 0 \leq k < f_L(0), f_H(N_c - 1) < k \leq M/2, \end{cases} \quad (4.4.3-28)$$

where the bottom part of the equation represents the frequencies that are not altered by the channel gains. For the WB NS, the channel gains are applied in such a manner that the lowest and highest frequencies are modified by the closest adjacent frequency gain, or:

$$H(k) = \begin{cases} \gamma_{ch}(i)G(k) & ; f_L(i) \leq k \leq f_H(i), 0 \leq i < N_c \\ \gamma_{ch}(0)G(k) & ; 0 \leq k < f_L(0) \\ \gamma_{ch}(N_c - 1)G(k) & ; f_H(N_c - 1) < k \leq M / 2 \end{cases} . \quad (4.4.3-29)$$

It is also required that the magnitude of  $H(k)$  be even, and the phase be odd, so that the following condition is also imposed:

$$H(M - k) = H^*(k); \quad 0 < k < M/2, \quad (4.4.3-30)$$

where \* denotes complex conjugate. This guarantees that the imaginary part of the inverse DFT of  $H(k)$  will be zero (in Equation 4.4.3-34).

#### 4.4.3.13 Background Noise Estimate Update

If (and only if) the update flag is set ( $update\_flag == TRUE$ ), then update the channel noise estimate for the next frame by:

$$E_n(m+1, i) = \max \{ E_{min}, \alpha_n E_n(m, i) + (1 - \alpha_n) E_{ch}(m, i) \}; \quad 0 \leq i < N_c, \quad (4.4.3-31)$$

where  $E_{min} = 0.0625$  is the minimum allowable channel energy, and  $\alpha_n = 0.9$  is the channel noise smoothing factor. For the NB NS, the channel noise estimate shall be initialized for each of the first four frames to the estimated channel energy, i.e.:

$$E_n(m, i) = \max \{ E_{init}, E_{ch}(m, i) \} \quad ; 1 \leq m \leq 4, 0 \leq i < N_c, \quad (4.4.3-32)$$

where  $E_{init} = 16$  is the minimum allowable channel noise initialization energy. For the WB NS, the channel noise estimate shall be initialized as:

$$E_n(m, i) = \begin{cases} 0.5 \max\{E_{init}, E_{ch}(m, i)\} & ; m = 1 \\ 0.5E_n(m-1, i) + 0.5 \max\{E_{init}, E_{ch}(m, i)\} & ; 1 < m \leq 16 \end{cases} \quad (4.4.3-33)$$

where  $E_{init} = 0.0625$  is the minimum allowable channel noise initialization energy.

#### 4.4.3.14 Time Domain Signal Reconstruction

Convert the filtered signal to the time domain using the inverse DFT:

$$h(m, n) = \frac{1}{2} \sum_{k=0}^{M-1} H(k) e^{j2\pi nk/M}; \quad 0 \leq n < M \quad (4.4.3-34)$$

Complete the frequency domain filtering process by applying overlap-and-add. For NB NS:

$$h'(n) = \begin{cases} h(m, n) + h(m-1, n+L) & ; 0 \leq n < M-L, \\ h(m, n) & ; M-L \leq n < L. \end{cases} \quad (4.4.3-35)$$

and for WB NS ( $L = D = 160$ ):

$$h'(n) = h(m, n) \sin(\pi(n+0.5)/2L) + h(m-1, n+L) \sin(\pi(n+L+0.5)/2L); \quad 0 \leq n < L \quad (4.4.3-36)$$

where  $h(m-1, n+L)$  are the samples from the last part of the previous frame.

Finally, apply signal de-emphasis by:

$$s'(n + N_{offs}) = h'(n) + \zeta_d s'(n + N_{offs} - 1); \quad 0 \leq n < L \quad (4.4.3-37)$$

where  $\zeta_d = 0.8$  is the de-emphasis factor,  $\{s'(n)\}$  is the output buffer, and  $N_{offs}$  is the relative offset into the output buffer. Since the 10 ms per frame Noise Suppression is performed twice per 20 ms speech frame, the output for NB NS presented to Model Parameter Estimation comprises  $s'(n)$ ;  $160 \leq n < 320$ . Therefore,  $N_{offs} = 160$  for the first 10 ms NS frame and  $N_{offs} = 240$  for the second 10 ms NS frame. The data in the buffer from the previous frame shall be time shifted accordingly.

For the WB NS, the output comprises  $s'(n)$ ;  $160 \leq n < 480$ . Therefore,  $N_{offs} = 160$  for the first 10 ms frame and  $N_{offs} = 320$  for the second 10 ms frame.

#### 4.4.3.15 Zero Delay Overlap/Add

For the second WB NS frame only, the overlapped portion of the filtered frame  $h(m, n)$  is combined with a gain scaled version of the overlapped portion of the input signal  $d(m, n)$  to form an auxiliary signal  $h''(n)$ , given as:

$$h''(n) = h(m, n+L) \sin^2(\pi(n+0.5)/2L) + \gamma_{max} d(m, n+L) \cos^2(\pi(n+0.5)/2L); \quad 0 \leq n < L \quad (4.4.3-38)$$

where  $\gamma_{max}$  is the maximum noise suppression gain applied to the spectrum of the current frame in Equation 4.4.3-27, or:

$$\gamma_{max} = \max\{\gamma_{ch}(i)\}; \quad 0 \leq i < N_c \quad (4.4.3-39)$$

1 The auxiliary signal  $s_{aux}(n)$  is then generated by applying signal deemphasis according to:

$$2 \quad s_{aux}(n) = h^n(n) + \zeta_d s_{aux}(n-1); \quad 0 \leq n < L \quad (4.4.3-40)$$

3 where the deemphasis memory  $s_{aux}(-1)$  is initialized to the last sample of the primary NS output  
 4  $s_{aux}(-1) = s'(N_{offs} + L - 1)$ .

5 This process effectively produces a temporary auxiliary signal that can be used to extend the noise suppressed  
 6 frame into the future for the purposes of spectral and pitch analysis. That is, the auxiliary signal is used by the  
 7 Model Parameter Estimation (sec 4.6) as the “lookahead” part of the analysis frame, and is discarded on the  
 8 following frame as the proper noise suppressed frame becomes available. The purpose of this is twofold. First,  
 9 the net effect on end-to-end delay of the NS algorithm is zero, and second, an increased overlap/add of 10 ms  
 10 (coincidentally equal to the lookahead delay) allows for better spectral estimation and frequency domain  
 11 filtering operations within the NS algorithm.

12 **4.5 Analysis Filterbank**

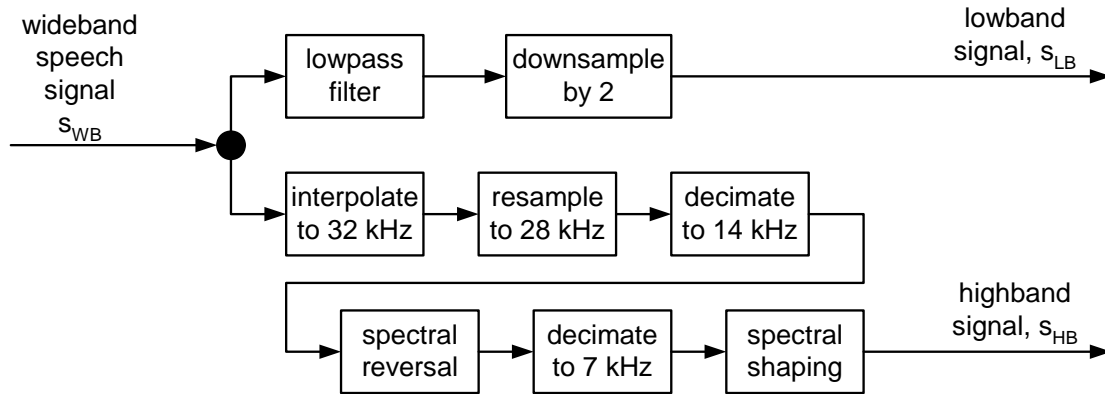

13

14

**Figure 4.5-1 Analysis Filter Bank**

15 **4.5.1 Generation of the lowband signal,  $s_{LB}$**

16 The lowpass filter and the downsample-by-2 can be realized as a polyphase implementation. The wideband  
 17 speech signal  $s_{WB}$  is first separate into odd time indexed and even time indexed subsequences. These  
 18 subsequences are filtered by two 13<sup>th</sup> order FIR filters and the outputs of these filters are added to derive the  
 19 lowband signal,  $s_{LB}$ .

20 **4.5.2 Generation of the highband signal,  $s_{HB}$**

21 **4.5.2.1 Interpolation to 32 kHz**

22 The 16 KHz signal  $s_{WB}$  is first upsampled to 32 KHz,  $s_{32}[n]$ , through the use of a 2-section polyphase  
 23 implementation.

24 The even components of  $s_{32}[n]$ , for  $n=0, 2, 4, 6$  etc are obtained by filtering  $s_{WB}[n/2]$  through an allpass filter  
 25 whose transfer function is given by

$$1 \quad H_{up2,0} = \left( \frac{a_{up2,0,0} + z^{-1}}{1 + a_{up2,0,0}z^{-1}} \right) \left( \frac{a_{up2,0,1} + z^{-1}}{1 + a_{up2,0,1}z^{-1}} \right)$$

2 And the odd components of  $s_{32}[n]$ , for  $n=1, 3, 5, 7$  etc are obtained by filtering  $s_{WB}[n/2]$  through an allpass filter  
3 whose transfer function is given by

$$4 \quad H_{up2,1} = \left( \frac{a_{up2,1,0} + z^{-1}}{1 + a_{up2,1,0}z^{-1}} \right) \left( \frac{a_{up2,1,1} + z^{-1}}{1 + a_{up2,1,1}z^{-1}} \right)$$

#### 5 4.5.2.2 Resampling to 28 KHz

6  $s_{32}[n]$  is resampled by a factor of 7/8 to obtain a 28 KHz signal,  $s_{28}[n]$ . This is obtained using a polyphase  
7 interpolation according to

$$8 \quad s_{28}(7n + j) = \sum_{k=0}^9 h_{32to28}(j, k) s_{32}(8n + j); \quad n = 0, 1, 2, \dots, 320/8 - 1, j = 0, 1, 2, \dots, 6$$

#### 9 4.5.2.3 Decimation to 14 Khz

10 The 28 KHz signal  $s_{28}$  is decimated to 14 Khz,  $s_{14}[n]$ , through the use of a 3-section polyphase implementation.

11 The even components of  $s_{28}[n]$ , for  $n=0, 2, 4, 6$  etc are filtered through an allpass filter whose transfer function  
12 is given by

$$13 \quad H_{down2,0} = \left( \frac{a_{down2,0,0} + z^{-1}}{1 + a_{down2,0,0}z^{-1}} \right) \left( \frac{a_{down2,0,1} + z^{-1}}{1 + a_{down2,0,1}z^{-1}} \right) \left( \frac{a_{down2,0,2} + z^{-1}}{1 + a_{down2,0,2}z^{-1}} \right)$$

14 And the odd components of  $s_{28}[n]$ , for  $n=1, 3, 5, 7$  etc are filtered through an allpass filter whose transfer  
15 function is given by

$$16 \quad H_{down2,1} = \left( \frac{a_{down2,1,0} + z^{-1}}{1 + a_{down2,1,0}z^{-1}} \right) \left( \frac{a_{down2,1,1} + z^{-1}}{1 + a_{down2,1,1}z^{-1}} \right) \left( \frac{a_{down2,1,2} + z^{-1}}{1 + a_{down2,1,2}z^{-1}} \right)$$

17 The outputs of these two polyphase components are averaged to yield the 14 KHz sampled signal,  $s_{14}$ .

#### 18 4.5.2.4 Spectral reversal

19 The spectrum of  $\hat{s}_{14}$  is reversed by multiplying the odd components by -1 to yield a signal  $s_{14}$ .

#### 20 4.5.2.5 Decimation to 7 Khz

21 The 14 KHz spectrally reversed signal  $s_{14}$  is decimated to 7 Khz,  $s_7[n]$ , through the use of a 3-section polyphase  
22 implementation.

23 The even components of  $s_{14}[n]$ , for  $n=0, 2, 4, 6$  etc are filtered through an allpass filter whose transfer function  
24 is given by

$$25 \quad H_{down2,1} = \left( \frac{a_{down2,0,1} + z^{-1}}{1 + a_{down2,0,1}z^{-1}} \right) \left( \frac{a_{down2,0,1} + z^{-1}}{1 + a_{down2,0,1}z^{-1}} \right)$$

26 And the odd components of  $s_{14}[n]$ , for  $n=1, 3, 5, 7$  etc are filtered through an allpass filter whose transfer  
27 function is given by

$$H_{down2,1} = \left( \frac{a_{down2,1,0} + z^{-1}}{1 + a_{down2,1,0}z^{-1}} \right) \left( \frac{a_{down2,1,0} + z^{-1}}{1 + a_{down2,1,0}z^{-1}} \right)$$

The outputs of these two polyphase components are added to yield the 7 KHz sampled signal,  $s_7$ .

#### 4.5.2.6 Spectral Shaping

The 7 KHz signal,  $s_7$ , is the shaped using a 1<sup>st</sup> order IIR shaping filter of the form

$$H_{shaping}(z) = 0.95 \frac{1 + z^{-1}}{1 - 0.9z^{-1}}$$

to obtain the highband signal,  $s_{HB}$ .

### 4.6 Model Parameter Estimation

Model Parameter Estimation comprises the linear predictive analysis, residual calculation and long-term prediction that must be performed for each frame, independent of the rate decision.

**Inputs:** The inputs to model parameter estimation are:

- The current 20 ms frame number,  $m$
- The pre-processed speech output vector,  $\{s'(n)\}$
- The unquantized line spectral pairs,  $\Omega(m-1)$ , calculated in the previous frame
- The LPC prediction gain,  $\gamma_{lpc}(m-1)$ , calculated in the previous frame

The pre-processed speech buffer,  $\{s'(n)\}$ , contains 320 pre-processed speech samples, i.e.,  $0 \leq n < 320$ . Samples 0 through 79 are “lookback” from the previous frame, samples 80 through 239 are the current frame, and samples 240 through 319 are “lookahead” to the next frame. The last 160 samples from the preprocessing modules, then, constitute 80 samples for the last half of the “current” frame and 80 samples “lookahead” to the next frame.

**Outputs:** The outputs of model parameter estimation are:

- The unquantized linear predictive coefficients for the current frame,  $\{a\}$
- The unquantized LSPs for the current frame,  $\Omega(m)$
- The LPC prediction gain,  $\gamma_{lpc}(m)$
- The prediction residual,  $\{e(n)\}$
- The long-term pitch delay estimate,  $\tau$
- The long-term prediction gain,  $\beta$
- The spectral transition indicator,  $LPCFLAG$
- The bandwidth expanded correlation coefficients,  $\mathbf{R}_w$

**Processing:** The model parameter estimation module performs three major functions:

- Calculation of the formant filter parameters and prediction gain
- Generation of the short-term prediction residual signal

- Calculation of the delay estimate and long-term prediction gain

In addition to these functions, this module also generates a spectral transition indicator, which is used to improve channel impairment performance. The following sections describe each of the major model parameter estimation functions in detail.

#### 4.6.1 Formant Filter Parameter Calculation

**Inputs:** The inputs to the formant filter parameter calculation are:

- The pre-processed speech input signal,  $\{s'(n)\}$
- The LPC prediction gain from the previous frame,  $\gamma_{lpc}(m-1)$

**Outputs:** The outputs of the formant filter parameter calculation are:

- The unquantized LPCs for the current frame  $\{a\}$
- The unquantized LSPs for the current frame,  $\Omega(m)$
- The LPC prediction gain,  $\gamma_{lpc}(m)$
- The impulse response of the formant filter,  $h(n)$
- The spectral transition indicator,  $LPCFLAG$

**Initialization:**

- The LPC prediction gain,  $\gamma_{lpc}(m) = 1$ , for  $m = 0$

**Processing:** The formant filter parameters are calculated from the pre-processed speech buffer,  $\{s'(n)\}$ , using the autocorrelation method and Durbin's Recursion. The details of the computation shall be executed as described in 4.6.1.1 through 4.6.1.3.

##### 4.6.1.1 Direct Form LPC Parameter Calculation

For Service Option 3, the pre-processed speech buffer is windowed using a Hamming window centered at the end of the current frame, i.e., on sample 239. The equation for the Hamming window is:

$$W_H(k) = 0.54 - 0.46 \cos\left(\frac{2\pi}{160}(k-160)\right); \quad 160 \leq k < 320, \quad (4.6.1-1)$$

and the expression for the windowed speech is:

$$s'_H(k-160) = W_H(k)s'(k); \quad 160 \leq k < 320. \quad (4.6.1-2)$$

The first 17 terms of the autocorrelation function of  $\{s'_H(n)\}$ ,  $\mathbf{R}$ , are calculated directly using:

$$R(k) = \sum_{i=0}^{159-k} s'_H(i)s'_H(i+k); \quad 0 \leq k < 16. \quad (4.6.1-3)$$

For Service Options 68 and 70, the pre-processed speech buffer is windowed using the assymmetric window given by

$$W_H(k) = \frac{\left(0.5 - 0.5 \cos\left(\frac{2\pi}{320}k\right)\right) e^{\frac{8.4k}{320}}}{286.5}; \quad 0 \leq k < 320 \quad (4.6.1-4)$$

and the expression for the windowed speech is:

$$s'_H(k) = W_H(k)s'(k); \quad 0 \leq k < 320 \quad (4.6.1-5)$$

The first 17 terms of the autocorrelation function of  $\{s'_H(n)\}$ ,  $\mathbf{R}$ , are calculated directly using:

$$R(k) = \sum_{i=0}^{320-k} s'_H(k)s'_H(i+k); \quad 0 \leq k < 16 \quad (4.6.1-6)$$

The first 11 are used for LPC analysis, while all 17 terms are used by the Rate Determination Algorithm (see 4.3). The autocorrelation terms are then spectrally smoothed by windowing as follows:

$$R_w(k) = \begin{cases} 1.00003R(k); & k = 0, \\ \exp\left[-\frac{1}{2}\left(\frac{40\pi k}{8000}\right)^2\right]R(k); & 1 \leq k \leq 16. \end{cases} \quad (4.6.1-7)$$

The unquantized, unweighted LPCs,  $\{\alpha\}$  are then calculated from  $\mathbf{R}_w$  using Durbin's Recursion<sup>†</sup>, as follows:

$$\begin{aligned} & \{ \\ & \quad E^{(0)} = R_w(0) \\ & \quad i = 1 \\ & \quad \text{while } (i \leq 10) \\ & \quad \{ \\ & \quad \quad k_i = \frac{1}{E^{(i-1)}} \left[ R_w(i) - \sum_{j=1}^{i-1} \alpha_j^{(i-1)} R_w(i-j) \right] \\ & \quad \quad \alpha_i^{(i)} = k_w \\ & \quad \quad j = 1 \\ & \quad \quad \text{while } (j < i) \\ & \quad \quad \{ \\ & \quad \quad \quad \alpha_j^{(i)} = \alpha_j^{(i-1)} - k_i \alpha_{i-j}^{(i-1)} \\ & \quad \quad \quad j = j + 1 \\ & \quad \quad \} \\ & \quad \quad E^{(i)} = (1 - k_i^2) E^{(i-1)} \\ & \quad \quad i = i + 1 \\ & \quad \} \\ & \} \end{aligned}$$

<sup>†</sup> See Rabiner, L. R. and Schafer, R. W., *Digital Processing of Speech Signals*, (New Jersey: Prentice-Hall Inc, 1978), pp. 411-412. The superscripts in parentheses represent the stage of Durbin's recursion. For example  $\alpha_j^{(i)}$  refers to  $\alpha_j$  at the  $i$ th stage.

1                    }  
2                    }

3 The LPC coefficients are  $\alpha_j^{(10)}$ , for  $1 \leq j \leq 10$ , or  $\{\alpha\} = \{\alpha_1, \alpha_2, \dots, \alpha_{10}\}$ .

4 In SO 68, two additional parameters called “stoporder15”, and “stoporder30” are monitored during the  
5 Levinson Durbin recursion. These correspond to the iteration numbers where the prediction gains first cross 15  
6 dB and 30 dB respectively, and are defined by.

7 Stoporder15 = iteration index when  $\frac{E^i}{E^0} > 10^{\frac{15}{10}}$ , and

8 Stoporder30 = iteration index when  $\frac{E^i}{E^0} > 10^{\frac{30}{10}}$ .

9 If Stoporder30  $\leq 4$ , the frame is encoded using Full-rate CELP.

10 If Stoporder15  $\leq 4$ , and the frame is chosen for Half-rate CELP coding by the Voice Activity Detection  
11 function, then the frame is encoded using Full-rate CELP.

#### 12 4.6.1.2 Generation of Spectral Transition Indicator (*LPCFLAG*)

13 For SO 3 only, the impulse response,  $\{h_{raw}\}$ , of the unweighted, unquantized formant filter is calculated to 54  
14 terms. The unweighted, unquantized formant filter is given by:

$$15 \quad \frac{1}{A_{raw}(z)} = \frac{1}{1 - \sum_{k=1}^{10} \alpha_k z^{-k}}, \quad (4.6.1-8)$$

16 where  $k$  is the LPC index. The energy of the raw impulse response is then calculated as an estimate of the LPC  
17 prediction gain. This is given by:

$$18 \quad \gamma_{lpc}(m) = \sum_{k=0}^{53} h_{raw}^2(k). \quad (4.6.1-9)$$

19 If the ratio  $\gamma_{lpc}(m)/\gamma_{lpc}(m-1) > 10$  (where  $\gamma_{lpc}(m-1)$  is the LPC prediction gain from the previous frame), then the  
20 spectral transition indicator, *LPCFLAG*, is set to 1, indicating that a large spectral transition has occurred.  
21 Otherwise, *LPCFLAG* is set to 0.

#### 22 4.6.1.3 Direct Form LPC to LSP Conversion

23 The raw LPCs are bandwidth expanded using an exponential window:

$$24 \quad \alpha_k = (0.994)^k \alpha_k \quad ; 0 < k \leq 10 \quad (4.6.1-10)$$

25 The unquantized, bandwidth expanded LPCs are then converted to LSPs. Here,  $A(z)$  is given by:

$$26 \quad A(z) = 1 - \sum_{k=1}^{10} \alpha_k z^{-k}, \quad (4.6.1-11)$$

1 where  $\{a_i\}$  are the bandwidth expanded LPC coefficients.

2 Next, define  $P_A(z)$  and  $Q_A(z)$  as follows:

$$3 \quad P_A(z) = A(z) + z^{-11}A(z^{-1}) = 1 + \sum_{i=1}^5 p_i z^{-i} + \sum_{i=6}^{10} p_{11-i} z^{-i} + z^{-11} \quad , \quad (4.6.1-12)$$

$$4 \quad Q_A(z) = A(z) - z^{-11}A(z^{-1}) = 1 + \sum_{i=1}^5 q_i z^{-i} - \sum_{i=6}^{10} q_{11-i} z^{-i} - z^{-11} \quad , \quad (4.6.1-13)$$

5 where  $p_i = -a_i - a_{11-i}$ ;  $1 \leq i \leq 5$ , and  $q_i = -a_i + a_{11-i}$ ;  $1 \leq i \leq 5$ . The LSP frequencies are the ten roots which exist  
6 between  $\omega = 0$  and  $\omega = 0.5$  in the following two equations:

$$7 \quad P'(\omega) = \cos 5(2\pi\omega) + p'_1 \cos 4(2\pi\omega) + \dots + p'_4 \cos (2\pi\omega) + p'_5/2 \quad , \quad (4.6.1-14)$$

$$8 \quad Q'(\omega) = \cos 5(2\pi\omega) + q'_1 \cos 4(2\pi\omega) + \dots + q'_4 \cos (2\pi\omega) + q'_5/2 \quad , \quad (4.6.1-15)$$

9 where the  $p'$  and  $q'$  values are computed recursively as follows from the  $p$  and  $q$  values:

$$10 \quad p'_0 = q'_0 = 1 \quad , \quad (4.6.1-16)$$

$$11 \quad p'_i = p_i - p'_{i-1} \quad 1 \leq i \leq 5 \quad , \quad (4.6.1-17)$$

$$12 \quad q'_i = q_i + q'_{i-1} \quad 1 \leq i \leq 5. \quad (4.6.1-18)$$

13 Since the formant synthesis (LPC) filter is stable, the roots of the two functions alternate; the smallest root,  $\omega_1$  is  
14 the lowest root of  $P'(\omega)$ , the next smallest root,  $\omega_2$  is the lowest root of  $Q'(\omega)$ , etc. Thus,  $\omega_1, \omega_3, \omega_5, \omega_7$ , and  $\omega_9$   
15 are the roots of  $P'(\omega)$ , and  $\omega_2, \omega_4, \omega_6, \omega_8$ , and  $\omega_{10}$  are the roots of  $Q'(\omega)$ . The corresponding unquantized LSP  
16 parameter vector is defined as:

$$17 \quad \Omega(m) = \{ \omega_1, \omega_2, \dots, \omega_{10} \} \quad . \quad (4.6.1-19)$$

#### 18 4.6.2 Generation of the Short-Term Prediction Residual

19 **Inputs:** The inputs to the short-term prediction residual calculation are:

- 20 • The unquantized LSPs from the previous frame,  $\Omega(m-1)$
- 21 • The unquantized LSPs calculated for the current frame,  $\Omega(m)$
- 22 • The pre-processed speech input vector,  $\{s'(n)\}$

23 **Output:** The output of short-term prediction residual calculation is:

- 24 • The residual vector,  $\{\varepsilon(n)\}$

25 This vector contains 320 elements, partitioned in the same way as the pre-processed speech input vector. The  
26 first 80 samples represent the last 10 ms of the previous frame; the next 160 samples represent the current 20  
27 ms frame, and the last 80 samples represent the 10 ms look-ahead.

1 **Initialization:** The unquantized LSPs,  $\Omega(m, i) = 0.048i$ ;  $m = 0, 1 \leq i \leq 10$ .

2 **Processing:** The short-term prediction residual signal,  $\{\varepsilon(n)\}$ , is generated by passing  $\{s'(n)\}$  through the  
 3 inverse filter created by interpolating between  $\Omega(m-1)$  and  $\Omega(m)$ . The  $\{s'(n)\}$  vector is divided into five  
 4 segments, and a different set of interpolated LSPs is computed for each corresponding segment. The  
 5 interpolated LSPs are converted to LPCs, and the appropriate segment of  $\{s'(n)\}$  is convolved with the resulting  
 6 filter to generate the corresponding samples of  $\{\varepsilon(n)\}$ . The initial state of the inverse filter shall be zero for  
 7 each frame,  $m$ , i.e., this is a zero state filter. Also, throughout the following discussion, variables with a “dot”  
 8 are implied to be interpolated, e.g.,  $\dot{\Omega}(m, k)$ .

#### 9 4.6.2.1 LSP Interpolation

10 For each segment  $k$ , the unquantized, interpolated LSP vector is:

$$11 \quad \dot{\Omega}(m, k) = (1 - \mu_k)\Omega(m-1) + \mu_k\Omega(m) \quad ; 0 \leq k \leq 4 \quad (4.6.2-1)$$

12 where the interpolator constants,  $\{\mu_k\}$ , and their corresponding sets of sample indices for each segment of  
 13  $\{s'(n)\}$  are given in Table 4.6.2.1-1.

14

15

16

**Table 4.6.2.1-1 LSP Interpolation Constants**

$k$	segment start sample	segment end sample	$\mu_k$
0	0	79	0.0
1	80	132	0.1667
2	133	185	0.5
3	186	239	0.8333
4	240	319	1.0

17

#### 18 4.6.2.2 LSP to Direct Form LPC Conversion

19 For each segment,  $0 \leq k \leq 4$ , the following process is executed. First,  $\dot{P}_A(z)$  and  $\dot{Q}_A(z)$  are computed from a  
 20 set of interpolated LSP frequencies,  $\dot{\Omega}(m, k)$ , as follows:

$$21 \quad \dot{P}_A(z) = (1 + z^{-1}) \prod_{j=1}^5 \left( 1 - 2z^{-1} \cos \left( 2\pi \dot{\omega}_{(2j-1)} \right) + z^{-2} \right), \quad (4.6.2-2)$$

$$22 \quad \dot{Q}_A(z) = (1 - z^{-1}) \prod_{j=1}^5 \left( 1 - 2z^{-1} \cos \left( 2\pi \dot{\omega}_{(2j)} \right) + z^{-2} \right), \quad (4.6.2-3)$$

1 where  $\{\dot{\omega}_1, \dot{\omega}_2, \dots, \dot{\omega}_{10}\} = \dot{\Omega}(m, k)$ , and the  $k$  is implied. These equations can also be expressed as:

$$2 \quad \dot{P}_A(z) = 1 + \sum_{i=1}^5 \dot{p}_i z^{-i} + \sum_{i=6}^{10} \dot{p}_{11-i} z^{-i} + z^{-11}, \quad (4.6.2-4)$$

$$3 \quad \dot{Q}_A(z) = 1 + \sum_{i=1}^5 \dot{q}_i z^{-i} - \sum_{i=6}^{10} \dot{q}_{11-i} z^{-i} - z^{-11}. \quad (4.6.2-5)$$

4 Then the LPC coefficients are computed from the coefficients of  $\dot{P}_A(z)$  and  $\dot{Q}_A(z)$  as follows:

$$5 \quad \dot{A}(z) = \frac{\dot{P}_A(z) + \dot{Q}_A(z)}{2}, \quad (4.6.2-6)$$

$$6 \quad = 1 + \sum_{i=1}^5 \frac{(\dot{p}_i + \dot{q}_i)}{2} z^{-i} + \sum_{i=6}^{10} \frac{(\dot{p}_{11-i} + \dot{q}_{11-i})}{2} z^{-i}, \quad (4.6.2-7)$$

$$7 \quad \dot{A}(z) = 1 - \sum_{i=1}^{10} \dot{a}_i z^{-i}. \quad (4.6.2-8)$$

8 So, the interpolated LPC coefficients for segment  $k$  of the current frame are given by:

$$9 \quad \dot{a}_i(k) = \begin{cases} -\frac{\dot{p}_i + \dot{q}_i}{2} & ; 1 \leq i \leq 5 \\ -\frac{\dot{p}_{11-i} + \dot{q}_{11-i}}{2} & ; 6 \leq i \leq 10 \end{cases} \quad (4.6.2-9)$$

#### 10 4.6.2.3 Generation of Residual Samples

11 The short-term prediction residual,  $\dot{\varepsilon}(n)$ , is generated by passing  $s'(n)$  through the inverse filter using the  
12 appropriate LPCs:

$$13 \quad \dot{\varepsilon}(n) = s'(n) - \sum_{i=1}^{10} \dot{a}_i(k) s'(n-i), \quad (4.6.2-10)$$

14 where the value for  $k$  in  $\dot{a}_i(k)$  is determined by the segment in which  $n$  lies as determined by the starting and  
15 ending sample numbers indicated in Table 4.6.2.1-1. All values of  $s'(n)$  for  $n < 0$  are zero.

#### 16 4.6.3 Calculation of the Delay Estimate and Long-Term Prediction Gain

17 **Inputs:** The input to the delay estimate and long-term prediction gain calculation is:

- 18 • The short-term residual vector,  $\{\dot{\varepsilon}(n)\}$

1 **Outputs:** The outputs of the delay estimate and long-term prediction gain calculation are:

- 2 • The pitch delay estimate,  $\tau$
- 3 • The long-term prediction gain,  $\beta$

4 **Initialization:** The values of all local state variables and buffers are set to zero at start-up.

5 **Processing:** The pitch delay shall be calculated using the method described in this section. The pitch delay is  
6 the delay that maximizes the autocorrelation function of the short-term prediction residual signal, subject to  
7 certain constraints. This calculation is carried out independently over two estimation windows. The first of  
8 these comprises the entire current frame; the second comprises the second half of the current frame and the  
9 look-ahead. Rules are then applied to combine the delay estimates and gains for the two estimation windows.  
10 The constrained search for the optimal delay in each window shall be carried out as follows:

11 The processes in 4.6.3.1 through 4.6.3.8 shall be performed once for each of the two estimation windows of  
12 each frame.

#### 13 4.6.3.1 Non-exhaustive Open Loop Delay Search

14 The residual signal,  $\{\varepsilon(n)\}$ , is filtered and decimated by a factor of four to generate the decimated residual  
15 signal,  $\{\varepsilon_d(n)\}$ , by applying:

$$16 \quad x(n) = \varepsilon(n + n_{start}) + 2.2875x(n-1) - 1.956x(n-2) + 0.5959x(n-3); \quad 0 \leq n < 80, \quad (4.6.3-1)$$

17 then:

$$18 \quad \varepsilon_d(n') = \varepsilon_d(n' + 20), \quad 0 \leq n' < 20, \quad (4.6.3-2)$$

19 and finally:

$$20 \quad \varepsilon_d(n') = x(4n' - 77) - 0.312[x(4n' - 78) + x(4n' - 79)] + x(4n' - 80), \quad 20 \leq n' < 40 \quad (4.6.3-3)$$

21 where  $\{x(n)\}$  is the decimator filter memory,  $\{\varepsilon_d(n)\}$  is the decimated residual buffer, and  $n_{start}$  is 160 for the  
22 first estimation window and 240 for the second estimation window. The autocorrelation function of this  
23 decimated residual signal is generated using:

$$24 \quad r(d) = \sum_{k=0}^{40-d} \varepsilon_d(k) \varepsilon_d(k+d) \quad ; \quad 5 \leq d \leq 30, \quad (4.6.3-4)$$

25 and the delay,  $d_{max}$ , corresponding to the maximum positive correlation,  $r_{max}$ , is found.

#### 26 4.6.3.2 Refinement of open loop delay estimate for SO 3

27 The following operations are then performed to determine whether to use  $d_{max}$  as the decimated delay estimate,  
28 or to use an estimate in the neighborhood of the smoothed delay estimate,  $\tilde{\tau}$ , instead:

$$29 \quad \text{if } (\tilde{\tau} \neq 0 \text{ AND } |\tilde{\tau} - 4d_{max}| > 2) \{$$

$$30 \quad \quad \text{if}(r'_{max} > 0.835 r_{max}) \{$$

$$31 \quad \quad \quad d_{max} = d'_{max}$$

$$32 \quad \quad \quad \}$$

$$33 \quad \quad \}$$

34 where  $d'_{max}$  is calculated as the delay corresponding to the maximum positive value of  $\{r(d)\}$  in the range:  $\max\{$   
35  $5, \lfloor \tilde{\tau} / 4 \rfloor - 2 \} \leq d \leq \min\{ 30, 4 + \max\{ 5, \lfloor \tilde{\tau} / 4 \rfloor - 2 \} \}$ , and  $\tilde{\tau}$  is updated per Equation 4.4.3-11.

36 The optimal delay estimate,  $D_{max}$ , is calculated as the index corresponding to  $R_{max}$ , which is the maximum  
37 positive value of:

$$R(D) = \sum_{n=0}^{159-D} \varepsilon(n+n_0)\varepsilon(n+n_0+D) ; \max\{20, 4d_{\max} - 3\} \leq D \leq \min\{120, 4d_{\max} + 3\}, \quad (4.6.3-5)$$

where  $n_0 = 80$  and 160 for the respective first and second estimation windows.

#### 4.6.3.3 Refinement of open loop delay estimate for SO 68 and SO 70

The original residual,  $\varepsilon(n)$ , is then used to compute additional correlation around  $d_{\max}$

$$rr(d) = \sum_{k=0}^{160-d} \varepsilon(k)\varepsilon(k+d); \quad M1 \leq d \leq M2, \quad (4.6.3-6)$$

where,  $M1 = \max(20, d_{\max} - 3)$ , and  $M2 = \min(120, d_{\max} + 3)$ .

and the delay,  $dd_{\max}$ , corresponding to the maximum positive correlation,  $rr_{\max}$ , is found, and the normalized correlation is:

$$\beta = \min \left( 1.0, \max \left( 0.0, \frac{rr_{\max}}{\text{sqr}t \left( \left( \sum_{k=0}^{160-dd_{\max}-1} (\varepsilon(k))^2 \right) \left( \sum_{k=dd_{\max}}^{160-1} (\varepsilon(k))^2 \right) \right)} \right) \right). \quad (4.6.3-7)$$

The following operations are then performed to determine whether to use  $dd_{\max}$  as the decimated delay estimate, or to use an estimate in the neighborhood of the smoothed delay estimate,  $\hat{\tau}$ , instead:

Similar to above, an estimate of the delay  $dp_{\max}$  within 6 samples of smoothed delay estimate  $\hat{\tau}$ , the corresponding maximum positive correlation,  $rp_{\max}$ , and the normalized correlation,  $\beta p$  are determined.

If  $\tilde{\tau} \neq 0$  AND  $|\tilde{\tau} - dd_{\max}| > 6$ , and if the normalized correlation around the smoothed delay estimate is greater than a weighted version of the normalized correlation of the current frame, then the delay estimate around the smoothed delay is used for the current frame. That is, if  $\beta p > w \cdot \beta$  (where  $w=0.6$  if  $dd_{\max} > \hat{\tau} + 6$ ,  $w=1.2$  if  $dd_{\max} > \hat{\tau} - 6$ ,  $w=10$  otherwise) then  $\beta = \beta p$ , and  $dd_{\max} = dp_{\max}$ .

A further check for pitch halving is performed to further refine the delay estimate if  $dd_{\max} > 40$ . Similar to above, an estimate of the delay  $dh_{\max}$  within 2 samples of smoothed delay estimate  $dd_{\max}/2$ , the corresponding maximum positive correlation,  $rh_{\max}$ , and the normalized correlation,  $\beta h$  are determined.

If  $\beta h > 0.8 \cdot \beta$ , then  $\beta = \beta h$ , and  $dd_{\max} = dh_{\max}$ .

22

#### 4.6.3.4 Long-Term Prediction Gain Calculation

The energy of the undecimated residual is calculated as follows:

$$R_{\varepsilon}(d) = \sqrt{\sum_{i=0}^{159-D_{\max}} \varepsilon^2(i+n_0) \sum_{j=0}^{159-D_{\max}} \varepsilon^2(j+n_0+D_{\max})}, \quad (4.6.3-8)$$

25

1 from which the long-term prediction gain can be derived by:

$$2 \quad \beta = \max \left\{ 0, \min \left\{ 1, \frac{R_{\max}}{R_{\varepsilon}(0)} \right\} \right\}. \quad (4.6.3-9)$$

### 3 4.6.3.5 Smoothed Delay Estimate and LTP Gain for SO3

4 The following operations are performed to determine whether to replace the values of  $\beta$  and  $D_{\max}$  calculated in  
5 4.6.3.1 and 4.6.3.2 by values obtained in the neighborhood of the smoothed delay estimate,  $\tilde{\tau}$  :

$$6 \quad \text{if}(\tilde{\tau} > 0) \{$$

$$7 \quad \quad \text{if} \left( (D_{\max} > \min\{120, \tilde{\tau} + 6\}) \text{ AND } (\beta' > 0.6\beta) \right) \text{ OR}$$

$$8 \quad \quad \left( (D_{\max} < \min\{20, \tilde{\tau} - 6\}) \text{ AND } (\beta' > 1.2\beta) \right) \{$$

$$9 \quad \quad \quad \beta = \beta'$$

$$10 \quad \quad \quad D_{\max} = D'_{\max}$$

$$11 \quad \quad \quad \}$$

$$12 \quad \quad \}$$

13 where  $D'_{\max}$  is the index of  $R'_{\max}$ , the maximum positive value of:

$$14 \quad R'(D) = \sum_{n=0}^{159-D} \varepsilon(n+n_0)\varepsilon(n+n_0+D) \quad ; \quad \max\{20, \tilde{\tau} - 6\} \leq D \leq \min\{120, \tilde{\tau} + 6\} \quad (4.6.3-10)$$

15 and:

$$16 \quad \beta' = \max \left\{ 0, \min \left\{ 1, \frac{R'_{\max}}{\sum_{i=0}^{159-D'_{\max}} \varepsilon^2(i+n_0) \sum_{j=0}^{159-D'_{\max}} \varepsilon^2(j+n_0+D'_{\max})} \right\} \right\}. \quad (4.6.3-11)$$

17 The smoothed delay and long-term prediction gain estimates are updated as follows:

$$18 \quad \tilde{\beta} = \begin{cases} \beta & ; \beta > 0.4, \\ 0.75\tilde{\beta} & ; \text{otherwise,} \end{cases} \quad (4.6.3-12)$$

19 then:

$$20 \quad \tilde{\tau} = \begin{cases} D_{\max} & ; \beta > 0.4, \\ \tilde{\tau} & ; \beta \leq 0.4 \text{ AND } \tilde{\beta} \geq 0.3, \\ 0 & ; \text{otherwise} \end{cases} \quad (4.6.3-13)$$

### 21 4.6.3.6 Smoothed delay estimate and LTP gain for SO 68 and SO 70

22 The smoothed delay and long-term prediction gain estimates are updated as follows:

$$\tilde{\beta} = \begin{cases} \beta & ; \beta > 0.4, \\ 0.75\tilde{\beta} & ; \text{otherwise,} \end{cases} \quad (4.6.3-14)$$

then:

$$\tilde{\tau} = \begin{cases} dd_{\max}; & \beta > 0.4 \\ \tilde{\tau}; & \beta \leq 0.4 \text{ AND } \tilde{\beta} \geq 0.3 \\ 0; & \text{otherwise} \end{cases} \quad (4.6.3-15)$$

#### 4.6.3.7 Composite Delay and Gain Calculations for SO 3

The delay estimates and long-term prediction gains for the two estimation windows are combined as follows:

Let  $(D_0, \beta_0)$  be the optimal delay and gain found for the window comprising the current frame, and let  $(D_1, \beta_1)$  be the optimal delay and gain found for the window comprising the second half of the current frame and the look-ahead. Then:

```

if (  $\beta_0 > \beta_1 + 0.4$  ) {
  if (  $|D_0 - D_1| > 15$  ) {
     $\tau = D_0$ 
     $\beta = \beta_0$ 
  }
  else {
     $\tau = (D_0 + D_1) / 2$ 
     $\beta = (\beta_0 + \beta_1) / 2$ 
  }
}
else {
   $\tau = D_1$ 
   $\beta = \beta_1$ 
}

```

#### 4.6.3.8 Composite delay and gain calculations for SO 68 and SO 70

The delay estimates and long-term prediction gains for the two estimation windows are combined as follows:

Let  $(D_0, \beta_0)$  be the optimal delay and gain found for the window comprising the current frame, and let  $(D_1, \beta_1)$  be the optimal delay and gain found for the window comprising the second half of the current frame and the look-ahead. Then:

```

1
2     if (  $\beta_0 > \beta_1 + 0.4$  ) {
3         if (  $|D_0 - D_1| > 15$  ) {
4              $\tau = D_0$ 
5              $\beta = \beta_0$ 
6         }
7         else {
8              $\tau = (D_0 + D_1) / 2$ 
9              $\beta = (\beta_0 + \beta_1) / 2$ 
10        }
11    }
12    else if (  $\beta_0 > \beta_1 + 0.05$  AND  $|D_0 - last\_delay < 7|$  ) {
13        if (  $|D_0 - D_1| > 15$  ) {
14             $\tau = D_0$ 
15             $\beta = \beta_0$ 
16        }
17        else {
18            
$$\tau = \arg \max_d \left( \sum_{k=40}^{160-d} \varepsilon(k) \varepsilon(k+d) \right);$$

19            
$$\left( \frac{D_0 + D_1}{2} - 1 \right) \leq d \leq \left( \frac{D_0 + D_1}{2} + 1 \right)$$

20             $\beta = (\beta_0 + \beta_1) / 2$ 
21        }
22    }
23    else {
24         $\tau = D_1$ 
25         $\beta = \beta_1$ 
26    }
27

```

#### 4.7 Determining the Data Rate for SO 3 and Voice Activity Detection for SO 68 and SO 70

For SO 3, the rate determination algorithm (RDA) is used to select one of three encoding rates: Rate 1, Rate 1/2, and Rate 1/8. Active speech is encoded at Rate 1 or Rate 1/2, and background noise is encoded at Rate 1/8.

For SO 68 and SO 70, the RDA that is described here is essentially a Voice Activity Detector that first separates active speech from background noise. Mode-decision, and a final rate-determination described in Section 4.8, and Section 4.8.4 are used to determine the final coding rate, and type of speech coding.

The actual data rate used for encoding the input signal may be modified to be Rate 1/2 maximum for the purpose of inserting a signaling message (see 2.2.1). Refer to 1.1 for guidelines concerning potential variations of the RDA.

##### Inputs:

- The bandwidth expanded correlation coefficients,  $\mathbf{R}_W$
- The long-term prediction gain,  $\beta$

##### Outputs:

- 1 • The speech encoder rate for the current frame,  $Rate(m)$

2 **Initialization:**

- 3 • The rate histories,  $Rate(m-1)$  and  $Rate(m-2)$ , are set to Rate 1/8 frames.
- 4 • The band energy,  $E_{f(i)}^{sm}(m)$ , initialization is given in 4.7.2.1.
- 5 • The background noise estimate,  $B_{f(i)}(m)$ , initialization is given in 4.7.2.2.
- 6 • The signal energy estimate,  $S_{f(i)}(m)$ , initialization is given in 4.7.2.3.

7 **Processing:**

- 8 • The data rate shall be determined by the processing steps defined in 4.7.1 and 4.7.2.

9 4.7.1 Estimating the Data Rate Based on Current Signal Parameters

10 The encoding rate is determined by comparing the current frame energy in each of two frequency bands,  $f(1)$   
 11 and  $f(2)$ , to background noise estimates in these respective bands. Thresholds above the background noise in  
 12 each band are determined by an estimated signal-to-noise ratio in each band. These thresholds are set for Rate  
 13 1, Rate 1/2, and Rate 1/8 encoding. The highest rate calculated from the two frequency bands is then selected  
 14 as the encoding rate for the current frame.

15 4.7.1.1 Computing Band Energy

16 The rate determination algorithm uses energy thresholds to determine the encoding rate for the current frame.  
 17 The input speech is divided into two distinct bands: band  $f(1)$  spans 0.3-2.0 kHz, band  $f(2)$  spans 2.0-4.0 kHz.†  
 18 The band energy for band  $f(i)$ ,  $BE_{f(i)}$ , is calculated as

$$19 \quad BE_{f(i)} = R_w(0)R_{f(i)}(0) + 2.0 \sum_{k=1}^{L_h-1} R_w(k)R_{f(i)}(k) \quad (4.7.1-1)$$

20 where:

$$21 \quad R_{f(i)}(k) = \sum_{n=0}^{L_h-1-k} h_i(n)h_i(n+k) \quad ; 0 \leq k < L_h \quad (4.7.1-2)$$

22 and  $h_i(n)$  is the impulse response of the band-pass filter  $i$ , where  $i = 1, 2$ .  $R_w(k)$  is the autocorrelation sequence  
 23 defined in Equation 4.4.1-7, and  $L_h = 17$  is the length of the impulse response of the band-pass filters.

24 The band-pass filters used for both frequency bands are defined in Table 4.7.1.1-1.

---

† Whenever a variable (or symbol or value) with a subscript  $f(i)$  appears in any equation or pseudocode in 4.5, it refers to a variable (or symbol or value) associated with either band  $f(1)$  or band  $f(2)$ .

1

Table 4.7.1.1-1 FIR Filter Coefficients Used for Band Energy Calculations

$n$	$h_1(n)$ (lower band)	$n$	$h_2(n)$ (upper band)
0	-5.557699E-02	0	-1.229538E-02
1	-7.216371E-02	1	4.376551E-02
2	-1.036934E-02	2	1.238467E-02
3	2.344730E-02	3	-6.243877E-02
4	-6.071820E-02	4	-1.244865E-02
5	-1.398958E-01	5	1.053678E-01
6	-1.225667E-02	6	1.248720E-02
7	2.799153E-01	7	-3.180645E-01
8	4.375000E-01	8	4.875000E-01
9	2.799153E-01	9	-3.180645E-01
10	-1.225667E-02	10	1.248720E-02
11	-1.398958E-01	11	1.053678E-01
12	-6.071820E-02	12	-1.244865E-02
13	2.344730E-02	13	-6.243877E-02
14	-1.036934E-02	14	1.238467E-02
15	-7.216371E-02	15	4.376551E-02
16	-5.557699E-02	16	-1.229538E-02

## 2 4.7.1.2 Calculating Rate Determination Thresholds

3 The rate determination thresholds for each frequency band  $f(i)$  are a function of both the background noise  
4 estimate,  $B_{f(i)}(m-1)$ , and the signal energy estimate,  $S_{f(i)}(m-1)$ , of the previous or  $(m-1)$ th frame. Two  
5 thresholds for each band are computed as

$$6 \quad T_1(B_{f(i)}(m-1), SNR_{f(i)}(m-1)) = k1(SNR_{f(i)}(m-1))B_{f(i)}(m-1), \quad (4.7.1-3)$$

$$7 \quad T_2(B_{f(i)}(m-1), SNR_{f(i)}(m-1)) = k2(SNR_{f(i)}(m-1))B_{f(i)}(m-1), \quad (4.7.1-4)$$

8 where the integer  $SNR_{f(i)}(m-1)$  is:

$$9 \quad SNR_{f(i)}(m-1) = \begin{cases} 0 & ; QSNRU_{f(i)}(m-1) < 0, \\ QSNRU_{f(i)}(m-1) & ; 0 \leq QSNRU_{f(i)}(m-1) \leq 7 \\ 7 & ; QSNRU_{f(i)}(m-1) > 7 \end{cases} \quad (4.7.1-5)$$

10 and where:

$$11 \quad QSNRU_{f(i)}(m-1) = \text{round} \left\{ \left( 10 \log_{10} \left( S_{f(i)}(m-1) / B_{f(i)}(m-1) \right) - 20 \right) / 5 \right\}. \quad (4.7.1-6)$$

1 4.7.1.2.1 SO 3

2 The functions  $k1(\bullet)$  and  $k2(\bullet)$  are defined in Table 4.7.1.2.2-1, and  $B_{f(i)}(m-1)$  and  $S_{f(i)}(m-1)$  are defined in  
 3 4.7.2.2 and 4.7.2.3, respectively.

4

5 **Table 4.7.1.2.1-1 Threshold Scale Factors as a Function of SNR**

$SNR_{f(i)}(m-1)$	$k1(SNR_{f(i)}(m-1))$	$k2(SNR_{f(i)}(m-1))$
0	7.0	9.0
1	7.0	12.6
2	8.0	17.0
3	8.6	18.5
4	8.9	19.4
5	9.4	20.9
6	11.0	25.5
7	31.6	79.6

6

7 4.7.1.2.2 SO 68 and SO 70

8 The functions  $k1(\bullet)$  and  $k2(\bullet)$  depend on the anchor operating point, and are defined in Table 4.7.1.2.2-1 to  
 9 Table 4.7.1.2.2-3, and  $B_{f(i)}(m-1)$  and  $S_{f(i)}(m-1)$  are defined in Sections 4.7.2.2 and 4.7.2.3, respectively.

10

11 **Table 4.7.1.2.2-1 Threshold scale factors as a function of SNR**

$SNR_{f(i)}(m-1)$	$k1(SNR_{f(i)}(m-1))$	$k2(SNR_{f(i)}(m-1))$
0	7.0	9.0
1	7.0	12.6
2	8.0	17.0
3	8.6	18.5
4	8.9	19.4
5	9.4	20.9
6	22.0	51.0
7	73.2	158.2

12

1

**Table 4.7.1.2.2-2 Threshold scale factors as a function of SNR**

<b>SNRf(i)(m-1)</b>	<b>k1(SNRf(i)(m-1))</b>	<b>k2(SNRf(i)(m-1))</b>
0	7.0	9.0
1	7.0	12.6
2	8.0	17.0
3	8.6	18.5
4	8.9	19.4
5	11.3	25.1
6	33.0	76.5
7	126.4	318.4

2

3

**Table 4.7.1.2.2-3 Threshold scale factors as a function of SNR**

<b>SNRf(i)(m-1)</b>	<b>k1(SNRf(i)(m-1))</b>	<b>k2(SNRf(i)(m-1))</b>
0	7.0	9.0
1	8.7	15.8
2	9.0	18.5
3	10.0	20.0
4	10.6	22.8
5	13.8	31.6
6	50.2	158.5
7	200.0	631.0

4

5 The threshold scale factors are identical for the low- and high-frequency bands.

#### 6 4.7.1.3 Comparing Thresholds

7 Band energy,  $BE_{f(i)}$ , is compared with two thresholds:  $T_1(B_{f(i)}(m-1), SNR_{f(i)}(m-1))$  and  $T_2(B_{f(i)}(m-1), SNR_{f(i)}(m-1))$ . If  $BE_{f(i)}$  is greater than both thresholds, Rate 1 is selected. If  $BE_{f(i)}$  is greater than only one threshold, Rate 1/2 is selected. If  $BE_{f(i)}$  is at or below both thresholds, Rate 1/8 is selected. This procedure is performed for both frequency bands and the higher of the two encoding rates selected from the individual bands is chosen as the preliminary data rate,  $Rate(m)$ , of the current frame  $m$ .

#### 12 4.7.1.4 Performing Hangover

13 If the preliminary data rate decision (from 4.7.1) transitions from at least two consecutive Rate 1 frames to a lower rate frame, then the next  $M$  frames are encoded as Rate 1 before allowing the encoding rate to drop to Rate 1/2 and finally to Rate 1/8. The number of hangover frames,  $M$ , is a function of the  $SNR_{f(1)}(m-1)$  (the

1 SNR in the lower frequency band) and is denoted as  $Hangover(SNR_{f(1)}(m-1))$  in Table 4.7.1.4.1-1.  $SNR_{f(1)}(m-$   
 2 1) is calculated as defined in Equation 4.5.1-5. The hangover algorithm is defined by the following  
 3 pseudocode:

```

4     {
5         if ( Rate(m) == Rate 1 )
6             count = 0
7         if ( Rate(m-1) == Rate 1 and Rate(m-2) == Rate 1 and Rate(m) != Rate 1 ) {
8             if ( count == 0 )
9                 M = Hangover(SNRf(1)(m-1))
10            if ( count < M ) {
11                Rate(m) = Rate 1
12                count = count + 1
13            }
14        }
15    }
    
```

16 where  $Rate(m)$  is the rate of the current frame and  $Rate(m-1)$  and  $Rate(m-2)$  are the rates of the previous two  
 17 frames, respectively. Also, the rates for the previous frames, as used here, are those generated by the RDA  
 18 prior to override logic, and are, therefore, not subject to modification by external rate control as described in  
 19 4.7.1.5.

20 4.7.1.4.1 Hangover Table for SO 3

21

22

**Table 4.7.1.4.1-1 Hangover Frames as a Function of SNR**

SNR <sub>f(1)</sub> (m-1)	Hangover (SNR <sub>f(1)</sub> (m-1))
0	7
1	7
2	7
3	3
4	0
5	0
6	0
7	0

23 4.7.1.4.2 Hangover Table for SO 68 and SO 70

24 For SO 68 and SO 70, the hangover table is chosen to be one of Table 4.7.1.4.2-1 to Table 4.7.1.4.2-3  
 25 depending on the Anchor operating point (viz, required aggressiveness of the VAD to meet the capacity  
 26 operating point).

27

**Table 4.7.1.4.2-1 Hangover Frames as a Function of SNR**

SNR <sub>f(1)</sub> (m-1)	Hangover (SNR <sub>f(1)</sub> (m-1))

<b>SNRf(1)(m-1)</b>	<b>Hangover (SNRf(1)(m-1))</b>
0	5
1	5
2	4
3	3
4	0
5	0
6	0
7	0

1

2

**Table 4.7.1.4.2-2 Hangover Frames as a Function of SNR**

<b>SNRf(1)(m-1)</b>	<b>Hangover (SNRf(1)(m-1))</b>
0	4
1	4
2	2
3	2
4	0
5	0
6	0
7	0

3

4

**Table 4.7.1.4.2-3 Hangover Frames as a Function of SNR**

<b>SNRf(1)(m-1)</b>	<b>Hangover (SNRf(1)(m-1))</b>
0	4
1	3
2	2
3	1
4	0
5	0
6	0

SNRf(1)(m-1)	Hangover (SNRf(1)(m-1))
7	0

1

## 2 4.7.1.5 Constraining Rate Selection

3 The rate selected by the procedures described in 4.7.1.3 and 4.7.1.4 are used for the current frame except where  
4 it is modified by the following constraints.

5 If the previous frame was selected as Rate 1 and the current frame is selected as Rate 1/8, then the encoding rate  
6 of the current frame should be modified to Rate 1/2. There are no other restrictions on encoding rate  
7 transitions.

8 If the speech codec has been commanded to generate a Rate 1/2 maximum packet and the rate determined is  
9 Rate 1, it generates a Rate 1/2 packet. If the speech codec has been requested to generate a Blank packet, it  
10 generates a packet based on the rate determined by the rate determination algorithm (RDA).

## 11 4.7.2 Updating RDA Parameters

12 After the RDA is complete, RDA parameters shall be updated as described in 4.7.2.1 through 4.7.2.3.

## 13 4.7.2.1 Updating the Smoothed Band Energy

14 The band energy,  $BE_{f(i)}$ , calculated in Equation 4.5.1-1 is smoothed and used to estimate both the background  
15 noise energy (see 4.7.2.2) and signal energy (see 4.7.2.3) in each band. The smoothed band energy,  $E_{f(i)}^{sm}(m)$ ,  
16 is computed as:

$$17 \quad E_{f(i)}^{sm}(m) = \alpha_E(m)E_{f(i)}^{sm}(m-1) + (1 - \alpha_E(m))BE_{f(i)} \quad ; \quad 1 \leq i \leq 2 \quad (4.7.2-1)$$

18 where  $m$  refers to the current frame, and

$$19 \quad \alpha_E(m) = \begin{cases} 0 & ; m \leq 1, \\ 0.6 & ; m > 1. \end{cases} \quad (4.7.2-2)$$

20 This allows the smoothed band energy to be initialized to the band energy of the first frame ( $m = 1$ ).

## 21 4.7.2.2 Updating the Background Noise Estimate

22 An estimate of the background noise level,  $B_{f(i)}(m)$ , is computed for the current, or  $m$ th, frame using  $B_{f(i)}(m-1)$ ,  
23  $E_{f(i)}^{sm}(m)$  (see 4.7.2.1) and  $SNR_{f(i)}(m-1)$  (see 4.7.1.2). Pseudocode describing the background noise update for  
24 band  $f(i)$  is given as

25 {  
26 if (  $\beta < 0.30$  for 8 or more consecutive frames )  
27  $B_{f(i)}(m) = \min \{ E_{f(i)}^{sm}(m), 80954304, \max \{ 1.03B_{f(i)}(m-1), B_{f(i)}(m-1) + 1 \} \}$   
28 else {  
29 if (  $SNR_{f(i)}(m-1) > 3$  )  
30  $B_{f(i)}(m) = \min \{ E_{f(i)}^{sm}(m), 80954304, \max \{ 1.00547B_{f(i)}(m-1), B_{f(i)}(m-1) + 1 \} \}$   
31 else

```

1         Bf(i)(m) = min{ Esmf(i)(m), 80954304, Bf(i)(m-1) }
2     }
3     if (Bf(i)(m) < lownoise(i) )
4         Bf(i)(m) = lownoise(i)
5     }

```

6 where  $\beta$ ,  $E^{sm}f(i)(m)$ , and  $SNR_{f(i)}(m-1)$  are defined in 4.6.3 and Equations 4.5.2-1 and 4.5.1-5, respectively.  
7  $lownoise(1)$  equals 160.0 and  $lownoise(2)$  equals 80.0.

8 At initialization, the background noise estimate for the first frame,  $B_{f(i)}(0)$ , is set to 80,954,304 for both  
9 frequency bands, and the consecutive frame counter for  $\beta$  is set to zero. Initialization also occurs if the audio  
10 input to the encoder is disabled and then enabled.†

#### 11 4.7.2.3 Updating the Signal Energy Estimate

12 The signal energy,  $S_{f(i)}(m)$ , is computed as

```

13     {
14     If (  $\beta > 0.5$  for 5 or more consecutive frames )
15         Sf(i)(m) = max{ Esmf(i)(m), min{ 0.97Sf(i)(m-1), Sf(i)(m-1) - 1 } }
16     else
17         Sf(i)(m) = max{ Esmf(i)(m), Sf(i)(m-1) }
18     }

```

19 where  $\beta$  and  $E_{f(i)}^{sm}(m)$  are defined in Section 4.6.3 and Equation 4.5.2-1, respectively.

20 At initialization, the signal energy estimates for the first frame,  $S_{f(1)}(0)$  and  $S_{f(2)}(0)$ , are set to 51,200,000 and  
21 5,120,000, respectively, and the consecutive frame counter for  $\beta$  is set to zero. Initialization also occurs if the  
22 audio input to the encoder is disabled and then enabled.

## 23 4.8 Mode decision and Rate decision for SO 68 and SO 70

24 While the RDA block mentioned above aims to classify the speech broadly into speech, and background noise,  
25 the Mode-Decision block further classifies the non-silence part of the input is further classified using a multi-  
26 level decision logic into transition, voiced, unvoiced and end-of-word, based on a variety of features and the  
27 desired operating point.

### 28 4.8.1 Pitch-based NACF

29 An important feature that is used in the mode-decision is the pitch-based autocorrelation similar to the  $\beta$  that  
30 was computed in the Open-loop pitch section. The procedure for computing the pitch based NACF is shown in  
31 the flowcharts below.

#### 32 **Inputs**

33 residual – formant residual of current frame and look-ahead frame computed with unquantized LPC

---

† This prevents the silence before the audio is connected from being mistaken as unusually low background noise.

1  $D_0, D_1$  – delay estimates for the first and second subframe of the current frame

2 **Outputs**

3  $nacf[4]$  – NACF from 4-subframe NACF track searching, returned value

4  $nacf\_at\_pitch$  – Maximum NACF around pitch estimates for 3 subframes

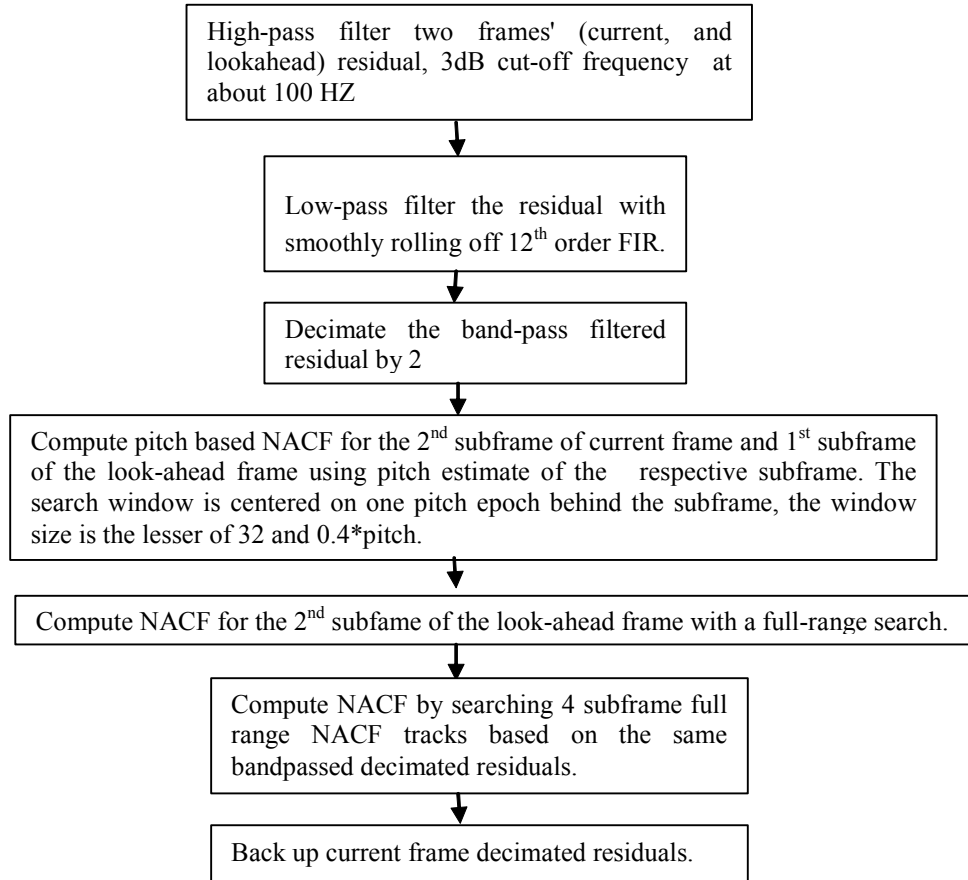

5

6

**Figure 4.8.1-1 Pitch-based NACF computation**

1 4.8.2 Pitch based NACF computation

2 The Open Loop Pitch Search provides the NACF, a key ingredient for mode.

3 4.8.2.1 Decimation of formant residual (current frames and look-ahead frames)

4 The formant residual of the current frame, and the look-ahead frame is first filtered through a 3rd order High-pass, with 3dB cut-off frequency at about 100 HZ.

6 It is then low-pass filtered with a FIR filter of length 13 and then decimated by a factor of 2. This decimated residual signal is denoted by  $r_d(n)$ .

8 4.8.2.2 NACF Computation for the two subframes of current frame

9 The normalized autocorrelation functions (NACFs) for two subframes of the current frame are computed as

$$10 \quad nacf(k) = MAX \left( \frac{\left( sign \left( \sum_{n=0}^{40-1} (r_d(40k+n)r_d(40k+n-lag(k)+i)) \right) \right) \left( \sum_{n=0}^{40-1} (r_d(40k+n)r_d(40k+n-lag(k)+i)) \right)^2}{\left( \sum_{n=0}^{40-1} (r_d(40k+n)r_d(40k+n)) \right) \left( \sum_{n=0}^{40-1} (r_d(40k+n-lag(k)+i)r_d(40k+n-lag(k)+i)) \right)} \right)$$

11 (4.8.2-1)

12 for  $k = 1, 2$ , and the maximization done over all integer  $i$  such that,

$$13 \quad - \frac{1 + MAX(6, MIN(0.2 \cdot pitchlag(k), 16))}{2} \leq i \leq \frac{1 + MAX(6, MIN(0.2 \cdot pitchlag(k), 16))}{2}$$

14 4.8.2.3 NACF computation for the look-ahead frame

15 The normalized autocorrelation functions (NACFs) for the lookahead subframe is computed as

$$16 \quad nacf(2) = MAX \left( \frac{\left( sign \left( \sum_{n=0}^{80-1} (r_d(80+n)r_d(80+n-i)) \right) \right) \left( \sum_{n=0}^{80-1} (r_d(80+n)r_d(80+n-i)) \right)^2}{\left( \sum_{n=0}^{80-1} (r_d(80+n)r_d(80+n)) \right) \left( \sum_{n=0}^{80-1} (r_d(80+n-i)r_d(80+n-i)) \right)} \right)$$

17 (4.8.2-2)

18 the maximization done over all integer  $i$  such that,

$$19 \quad \frac{20}{2} \leq i < \frac{120}{2}$$

1 4.8.3 Speech Coding Mode decision algorithm

2 **Definitions**

3 Transient – voiced but less periodic speech, encoded with full rate CELP

4 Up-transient – first voiced frame in active speech, encoded the same way as transient

5 Down-transient – low energy voiced speech typically at end of word, encoded with half rate CELP

6 Voiced – highly periodic voiced speech, mainly vowels. Will be further classified as full rate or  
7 quarter rate according to different patterns to meet ADR requirements

8 Unvoiced – unvoiced speech, mainly consonants. Encoded with quarter rate NELP

9 Silence – inactive speech. Encoded with eighth-rate same as EVRC

10 **Inputs**

11 curr\_va – current frame VAD, which comes from EVRC RDA

12 prev\_voiced – indicates the presence of stationary voiced speech in previous frame

13 prev\_mode – previous frame mode decision

14 nacf\_at\_pitch – subframe NACFs based on pitch estimates

15 curr\_ns\_snr – low and high band instantaneous SNRs from the noise suppressor

16 curr\_snr – low and high band instantaneous SNRs from the EVRC RDA (VAD)

17 t\_in – speech buffer, which has both the current frame and the look ahead frame speech

18 **Outputs**

19 Current frame mode decision

## 1 4.8.3.1 Energy and zero crossing rate

2 Energies in the 0 to 2 kHz band and 2 to 4 kHz band are computed as  $EL = \sum_{n=0}^{159} s_L^2(n)$ , and  $EH = \sum_{n=0}^{159} s_H^2(n)$   
 3 respectively, where  $s_L(n)$ , and  $s_H(n)$  are the low-pass filtered (using a 12th order pole-zero LPF), and the  
 4 high-pass filtered (using a 12th order pole-zero HPF) versions of the input speech respectively. The speech  
 5 signal energy itself is  $E = \sum_{n=0}^{159} s^2(n)$ .

6 The zero crossing rate ZCR is computed as

7 If  $(s(n)s(n+1)<0)$  ZCR=ZCR+1,  $0 \leq n < 159$

8 Table 4.8.3.1-1 describes the features used in the mode decision.

9

10

**Table 4.8.3.1-1 Features used in mode decision**

Feature name	Description
curr_ns_snr	This feature is extracted from the noise suppressor. It's the band SNRs derived from the FFT. Low band is from 0 to 2 kHz, high band is from 2 to 4 kHz.
curr_snr	This is the band SNRs derived from VAD, after noise suppression.
curr_snr_diff	Band SNR difference, defined as curr_snr[0]-curr_snr[1]
zcr	This is the zero crossing rate of the current frame, defined as the number of sign changes in speech.
E	Current frame energy
Enext	Look ahead frame energy
bER	Band energy ratio, defined as $\log_2(EL/EH)$ , where EL is the low band current frame energy from 0 to 2k, and EH is the high band current frame energy from 2k to 4k.
vEav	3-frame average voiced energy, updated only if current frame is voiced, or reset to 0.1 at unvoiced or inactive speech.
vEprev	Previous valid 3-frame average voiced energy
vER	Current energy to previous 3-frame average voiced energy ratio, defined as $10 \cdot \log_{10}(E/vEprev)$ .
vER2	Defined as $\text{MIN}(20, 10 \cdot \log_{10}(E/vEav))$
maxsfe_idx	Current frame is evenly divided into 10 subframes, r.m.s value is computed on each subframe. This is the index to the subframe that has the largest r.m.s value in the second half of the current frame.

11

1 The flow chart in Figure 4.8.3.1-1 illustrates the high level mode-decision scheme.

2

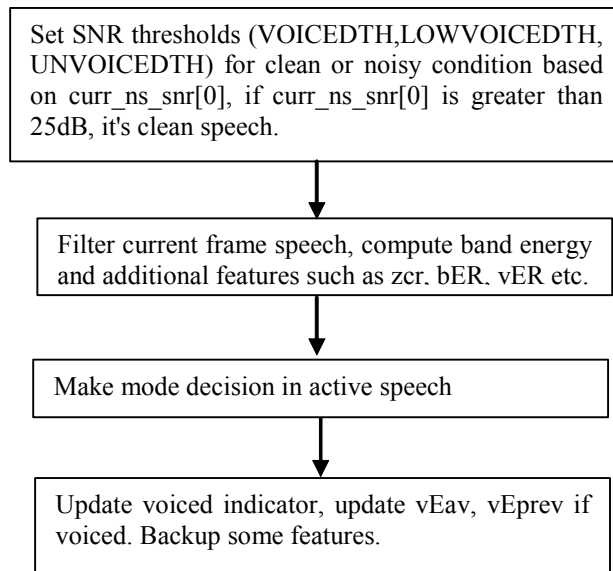

3

4 **Figure 4.8.3.1-1 High level diagram of mode decision**

5

6 The various features are used in a multilevel decision logic to make the mode-decision. The following diagrams  
 7 outline how the mode decision is made. Current mode decision is a transition between states based on the  
 8 previous mode decision and features such as NACFs. The states are the different modes that correspond to  
 9 different coding schemes.

10 na cf\_at\_pitch[2]>VOICEDTH – second subframe NACF of the current frame is high

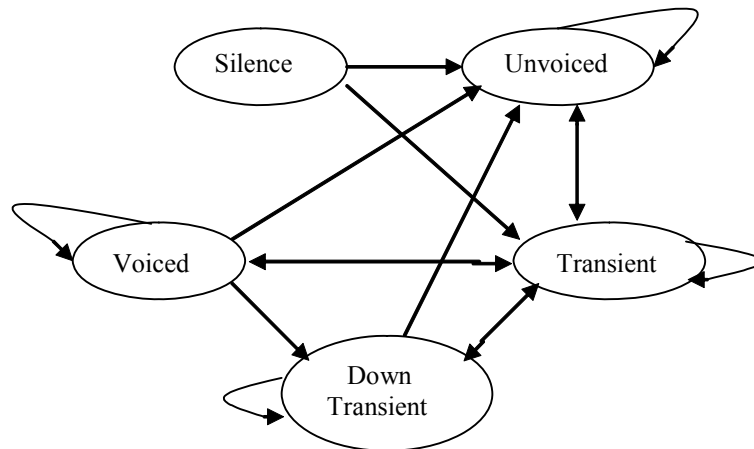

11

12 **Figure 4.8.3.1-2 na cf\_at\_pitch[2]>VOICEDTH – second subframe NACF of the current frame is high**

1 The following pseudo-code shows the decision making process using the features mentioned above, and  
 2 detailing the above state transition diagram.

```

3
4     if ( nacf_ap[2]>=VOICEDTH ) { // 2nd subframe NACF high
5         switch (prev_mode) {
6
7             case SILENCE:
8                 m.speech_type=UP_TRANSIENT;
9                 if (nacf_ap[3]<UNVOICEDTH && zcr>70 && bER<0)
10                    m.speech_type=UNVOICED;
11                 if (nacf_ap[3]<UNVOICEDTH && zcr>100 && vER<-20)
12                    m.speech_type=UNVOICED;
13                 if (vER<-25)
14                    m.speech_type=UNVOICED;
15
16                 break;
17
18             case UNVOICED:
19                 m.speech_type=UP_TRANSIENT;
20                 if (nacf_ap[3]<UNVOICEDTH && nacf_ap[4]<UNVOICEDTH &&
21                    nacf<UNVOICEDTH && zcr>70 && bER<0)
22                    m.speech_type=UNVOICED;
23                 if (nacf_ap[3]<UNVOICEDTH && zcr>100 && vER<-20 && E<Eprev)
24                    m.speech_type=UNVOICED;
25                 if (vER<-25)
26                    m.speech_type=UNVOICED;
27
28                 break;
29
30             case VOICED:
31                 m.speech_type=VOICED;
32                 /*
33                 if ((nacf_ap[2]-nacf_ap[3]>0.3) && nacf_ap[3]<LOWVOICEDTH &&
34                    E>=2*Eavg)
35                    m.speech_type=TRANSIENT;
36                 */
37                 if ((nacf_ap[2]-nacf_ap[1]>0.3) && nacf_ap[1]<LOWVOICEDTH &&
38                    E>0.5*Eprev)
39                    m.speech_type=TRANSIENT;
40                 if (vER<-18 && nacf_ap[3]<VOICEDTH)
41                    m.speech_type=DOWN_TRANSIENT;
42                 if (vER<-30 && E<Eprev)
43                    m.speech_type=UNVOICED;
44                 break;
45

```

```

1      case DOWN_TRANSIENT:
2          m.speech_type=DOWN_TRANSIENT;
3          //      if (E>0.2*vEav) m.speech_type=TRANSIENT;
4          if (vER<-30)
5              m.speech_type=UNVOICED;
6          if (E>Eprev) m.speech_type=TRANSIENT;
7          break;
8
9      default: // previous is transient
10         m.speech_type=VOICED;
11         if ((nacf_ap[2]-nacf_ap[1]>0.45) || nacf_ap[1]<UNVOICEDTH )
12             m.speech_type=TRANSIENT;
13         if (nacf_ap[1]-nacf_ap[0]>0.3 && nacf_ap[1]<VOICEDTH &&
14             prev_mode !=TRANSIENT)
15             m.speech_type=TRANSIENT;
16
17         if (((nacf_ap[1]-nacf_ap[0]>0.3) || (nacf_ap[2]-nacf_ap[1]>0.3))
18             && nacf_ap[1]<LOWVOICEDTH && nacf_ap[0]<UNVOICEDTH)
19             m.speech_type=TRANSIENT;
20
21         if (E<0.05*vEav && nacf_ap[3]<VOICEDTH)
22             m.speech_type=DOWN_TRANSIENT;
23         if (vER<-30 && E<Eprev)
24             m.speech_type=UNVOICED;
25         break;
26     }
27 }

```

29 nacf\_at\_pitch[2]<UNVOICEDTH – second subframe NACF of the current frame is low

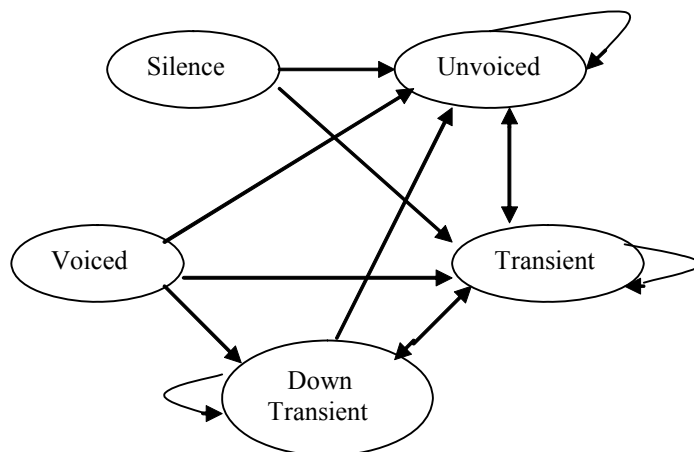

30

31 **Figure 4.8.3.1-3 nacf\_at\_pitch[2]<UNVOICEDTH – second subframe NACF of the current frame is low**

32 The following pseudo-code shows the decision making process using the features mentioned above, and  
 33 detailing the above state transition diagram.

```

1
2     if ( nacf_ap[2]<=UNVOICEDTH ) {
3         switch (prev_mode) {
4
5             case SILENCE:
6                 m.speech_type=UNVOICED;
7                 if (nacf_ap[3]>nacf_ap[2] && nacf_ap[4]>nacf_ap[3] &&
8 nacf_ap[4]>LOWVOICEDTH && zcr<110 && vER>-21 && (nacf_ap[3]>UNVOICEDTH ||
9 bER>-2))
10                    m.speech_type=UP_TRANSIENT;
11                    if (zcr<60 && bER>6 && vER>-13 && curr_snr_diff>13.5463)
12                        m.speech_type=UP_TRANSIENT;
13                        if ((nacf_ap[3]>LOWVOICEDTH || nacf_ap[4]>LOWVOICEDTH) && bER>3 &&
14 zcr<60 && vER>0)
15                            m.speech_type=UP_TRANSIENT;
16                            if (nacf_ap[3]>LOWVOICEDTH && nacf_ap[4]>LOWVOICEDTH && bER>3 &&
17 zcr<40 && vER>-15)
18                                m.speech_type=UP_TRANSIENT;
19                                break;
20
21                    case UNVOICED:
22                        m.speech_type=UNVOICED;
23                        if (nacf_ap[3]>nacf_ap[2] && nacf_ap[4]>nacf_ap[3] &&
24 nacf_ap[4]>LOWVOICEDTH && zcr<110 && vER>-21 && (nacf_ap[3]>UNVOICEDTH ||
25 bER>-2))
26                            m.speech_type=UP_TRANSIENT;
27                            if (nacf_ap[3]>nacf_ap[2] && nacf_ap[4]>nacf_ap[3] && E>5*Eprev &&
28 bER>3 && vER>-16)
29                                m.speech_type=UP_TRANSIENT;
30                                if (nacf_ap[4]>VOICEDTH && bER>3 && zcr<80 && E>2*Eprev && vER>-
31 20)
32                                    m.speech_type=UP_TRANSIENT;
33                                    if (nacf_ap[3]>VOICEDTH && bER>0 && zcr<80 && E>2*Eprev && vER>-
34 16)
35                                        m.speech_type=UP_TRANSIENT;
36                                        if ((nacf_ap[3]>LOWVOICEDTH || nacf_ap[4]>LOWVOICEDTH) && bER>0 &&
37 zcr<80 && maxsfe_idx==SFNUM && vER>-16)
38                                            m.speech_type=UP_TRANSIENT;
39                                            if (nacf_ap[3]>UNVOICEDTH && nacf_ap[4]>UNVOICEDTH && zcr<80 &&
40 bER>4 && vER>-20 && curr_snr_diff>0 && curr_ns_snr[0]>=SNR_THLD) // Clean
41 condition
42                                                m.speech_type=UP_TRANSIENT;
43
44                    if (nacf_ap[3]>LOWVOICEDTH && nacf_ap[4]>LOWVOICEDTH && zcr<80 &&
45 E>Eprev && vER>-20)
46                        m.speech_type=UP_TRANSIENT;
47                        if (nacf_ap[3]>VOICEDTH && nacf_ap[4]>VOICEDTH && vER>-20)

```

### 3GPP2 C.S0014-C ver 1.0

```
1         m.speech_type=UP_TRANSIENT;
2         if (bER>0 && zcr<80 && E>10*Eprev && vER>-10)
3             m.speech_type=UP_TRANSIENT;
4
5         if (((bER>5 && vER>-10) || (bER>3 && vER>-6) || (bER>0 && vER>-3))
6             && zcr<80 && curr_snr_diff>0 && curr_ns_snr[0]>=SNR_THLD) // Clean condition
7             m.speech_type=UP_TRANSIENT;
8
9         if (bER>-3 && vER>-14 && zcr<80 && curr_ns_snr[0]<SNR_THLD)
10            //Noisy condition
11            m.speech_type=UP_TRANSIENT;
12            if (nacf>UNVOICEDTH && zcr<60 && bER>2 && vER>-5 &&
13                curr_ns_snr[0]<SNR_THLD) //Noisy condition
14                m.speech_type=UP_TRANSIENT;
15                if (bER>-5 && vER>-4 && nacf_ap[3]>UNVOICEDTH &&
16                    nacf_ap[4]>nacf_ap[3] && zcr<100 && curr_ns_snr[0]<SNR_THLD) // Noisy
17                    condition
18                    m.speech_type=UP_TRANSIENT;
19
20            break;
21
22        case DOWN_TRANSIENT: // following down_transient
23            m.speech_type=UNVOICED;
24            if (bER>0) {
25                if (vER>-20 && zcr<70)
26                    m.speech_type=DOWN_TRANSIENT;
27                if ((nacf_ap[3]>LOWVOICEDTH || nacf_ap[4]>LOWVOICEDTH) &&
28                    E>=2*Eprev && vER>-15)
29                    m.speech_type=TRANSIENT;
30                if (nacf_ap[3]>nacf_ap[2] && nacf_ap[4]>nacf_ap[3] &&
31                    nacf_ap[4]>VOICEDTH && vER>-15 && E>Eprev)
32                    m.speech_type=TRANSIENT;
33            }
34            else {
35                if (nacf_ap[3]>nacf_ap[2] && nacf_ap[4]>nacf_ap[3] &&
36                    nacf_ap[4]>VOICEDTH && vER>-15 && E>2*Eprev)
37                    m.speech_type=TRANSIENT;
38            }
39            break;
40        case VOICED:
41        default:
42            if (bER>0) {
43                m.speech_type=TRANSIENT;
44                if (vER2<-15 && zcr<90 && E<Eprev && nacf_ap[3]<VOICEDTH)
45                    m.speech_type=DOWN_TRANSIENT;
46                if (vER<-25 && E<Eprev)
47                    m.speech_type=UNVOICED;
```

```

1         }
2         else {
3             m.speech_type=UNVOICED;
4             if (nacf_ap[3]>nacf_ap[2] && nacf_ap[4]>nacf_ap[3] &&
5                 nacf_ap[4]>UNVOICEDTH && zcr<100 && vER>-20 && curr_ns_snr[0]<SNR_THLD) //
6                 Noisy condition
7                 m.speech_type=TRANSIENT;
8                 if (nacf_ap[3]>nacf_ap[2] && nacf_ap[4]>nacf_ap[3] &&
9                     nacf_ap[4]>LOWVOICEDTH && zcr<100 && vER>-20 && curr_ns_snr[0]>=SNR_THLD) //
10                    Clean condition
11                    m.speech_type=TRANSIENT;
12
13                    if (((bER>-1 && vER>-12 && zcr<80) || (bER>-3 && vER>-10 &&
14                        zcr<90) || (bER>-7 && vER>-3 && zcr<105)) && curr_ns_snr[0]<SNR_THLD) //
15                        Noisy condition
16                        m.speech_type=TRANSIENT;
17                        if (bER>-3 && vER>-10 && zcr<90 && curr_ns_snr[0]>=SNR_THLD) //
18                            Clean condition
19                            m.speech_type=TRANSIENT;
20                    }
21                break;
22            }
23        }
24    }

```

25 nacf\_at\_pitch[2]>=UNVOICEDTH && nacf\_at\_pitch[2]<=VOICEDTH – major gray area

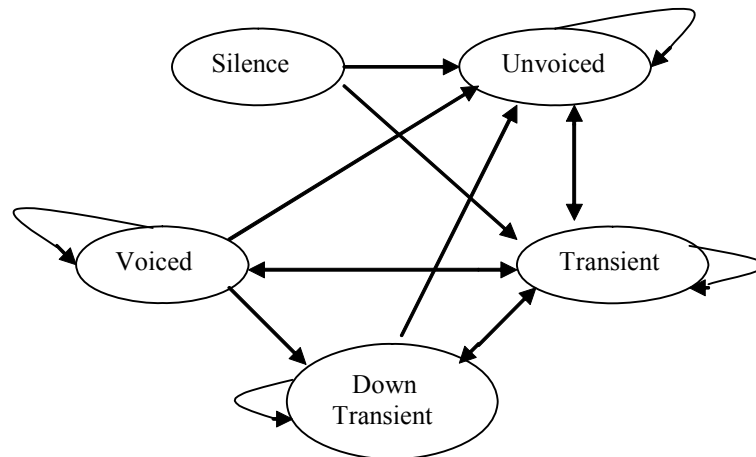

26

27 **Figure 4.8.3.1-4 nacf\_at\_pitch[2]>=UNVOICEDTH && nacf\_at\_pitch[2]<=VOICEDTH**

28

29 The following pseudo-code shows the decision making process using the features mentioned above, and  
30 detailing the above state transition diagram.

31

```

32     switch (prev_mode) {

```

33

### 3GPP2 C.S0014-C ver 1.0

```
1         case SILENCE:
2             m.speech_type=UNVOICED;
3             if (nacf_ap[3]>nacf_ap[2] && nacf_ap[4]>nacf_ap[3] &&
4 nacf_ap[4]>LOWVOICEDTH && zcr<110 && vER>-22)
5                 m.speech_type=UP_TRANSIENT;
6
7             if (nacf_ap[2]>LOWVOICEDTH && curr_snr_diff>0 && E>2*Eprev &&
8 zcr<70 && vER>-20)
9                 m.speech_type=UP_TRANSIENT;
10            if (nacf_ap[2]>LOWVOICEDTH && nacf_ap[3]>LOWVOICEDTH && zcr<70 &&
11 vER>-20)
12                m.speech_type=UP_TRANSIENT;
13            if ((nacf_ap[4]>VOICEDTH || nacf_ap[3]>VOICEDTH) &&
14 nacf_ap[3]>UNVOICEDTH && zcr<70 && vER>-20)
15                m.speech_type=UP_TRANSIENT;
16            if ((nacf_ap[3]-nacf_ap[2]>0.3) && E>2*Eprev && zcr<70 && bER>0 &&
17 vER>-20)
18                m.speech_type=UP_TRANSIENT;
19            if (nacf_ap[4]>VOICEDTH && (nacf_ap[2]>LOWVOICEDTH ||
20 nacf_ap[3]>LOWVOICEDTH) && E>2*Eprev && curr_snr_diff>0 && vER>-20)
21                m.speech_type=UP_TRANSIENT;
22            if (nacf_ap[3]>LOWVOICEDTH && nacf_ap[4]>LOWVOICEDTH && bER>3 &&
23 zcr<40 && vER>-15)
24                m.speech_type=UP_TRANSIENT;
25            break;
26
27        case UNVOICED:
28            m.speech_type=UNVOICED;
29            if (nacf_ap[3]>nacf_ap[2] && nacf_ap[4]>nacf_ap[3] &&
30 nacf_ap[4]>LOWVOICEDTH && zcr<110 && vER>-22)
31                m.speech_type=UP_TRANSIENT;
32            if ((nacf_ap[4]>LOWVOICEDTH || nacf_ap[3]>LOWVOICEDTH) && zcr<100
33 && E>Eprev && bER>0 && vER>-20)
34                m.speech_type=UP_TRANSIENT;
35            if (nacf_ap[4]>VOICEDTH && nacf>UNVOICEDTH && zcr<100 && E>Eprev
36 && bER>1 && vER>-16)
37                m.speech_type=UP_TRANSIENT;
38            if (zcr<60 && bER>3 && E>5*Eprev && curr_snr_diff>9.0309 && vER>-
39 20)
40                m.speech_type=UP_TRANSIENT;
41            if ((nacf_ap[3]>UNVOICEDTH || nacf_ap[4]>UNVOICEDTH) && bER>1 &&
42 vER>-16 && zcr<80 && curr_snr_diff>-6.0206)
43                m.speech_type=UP_TRANSIENT;
44
45            if (nacf_ap[2]>LOWVOICEDTH && curr_snr_diff>0 && E>2*Eprev &&
46 zcr<70 && vER>-20)
47                m.speech_type=UP_TRANSIENT;
```

```

1         if (nacf_ap[2]>LOWVOICEDTH && nacf_ap[3]>LOWVOICEDTH && zcr<100 &&
2 vER>-20)
3             m.speech_type=UP_TRANSIENT;
4             if ((nacf_ap[4]>VOICEDTH || nacf_ap[3]>VOICEDTH) &&
5 nacf_ap[3]>UNVOICEDTH && zcr<80 && vER>-20)
6                 m.speech_type=UP_TRANSIENT;
7                 if ((nacf_ap[3]>LOWVOICEDTH || nacf_ap[4]>LOWVOICEDTH) && bER>0 &&
8 zcr<100 && maxsfe_idx==SFNUM && vER>-20)
9                     m.speech_type=UP_TRANSIENT;
10                    if (nacf_ap[3]>UNVOICEDTH && nacf_ap[4]>UNVOICEDTH && zcr<100 &&
11 vER>-3 && bER>-5 && curr_ns_snr[0]<SNR_THLD) // Noisy condition
12                        m.speech_type=UP_TRANSIENT;
13
14                    if (bER>4 && zcr<100 && maxsfe_idx==SFNUM && vER>-20)
15                        m.speech_type=UP_TRANSIENT;
16
17                    if ((nacf_ap[3]-nacf_ap[2]>0.3) && E>2*Eprev && zcr<70 && bER>0 &&
18 vER>-20)
19                        m.speech_type=UP_TRANSIENT;
20                        if (nacf_ap[4]>VOICEDTH && (nacf_ap[2]>LOWVOICEDTH ||
21 nacf_ap[3]>LOWVOICEDTH) && E>2*Eprev && curr_snr_diff>0 && vER>-20)
22                            m.speech_type=UP_TRANSIENT;
23
24                        if (((bER>5 && vER>-10) || (bER>3 && vER>-6) || (bER>0 && vER>-3))
25 && zcr<80 && curr_ns_snr[0]>=SNR_THLD) // Clean condition
26                            m.speech_type=UP_TRANSIENT;
27
28                        if (bER>-3 && vER>-14 && zcr<80 && curr_ns_snr[0]<SNR_THLD) //
29 Noisy condition
30                            m.speech_type=UP_TRANSIENT;
31                            break;
32                    case DOWN_TRANSIENT:
33                        m.speech_type=UNVOICED;
34                        if (bER>0) {
35                            if (vER>-20 && zcr<70)
36                                m.speech_type=DOWN_TRANSIENT;
37                                if ((nacf_ap[3]>LOWVOICEDTH || nacf_ap[4]>LOWVOICEDTH) &&
38 E>=2*Eprev && vER>-15)
39                                    m.speech_type=TRANSIENT;
40                                    if (nacf_ap[3]>nacf_ap[2] && nacf_ap[4]>nacf_ap[3] &&
41 nacf_ap[4]>VOICEDTH && vER>-15)
42                                        m.speech_type=TRANSIENT;
43
44                                }
45                            else {
46                                if (nacf_ap[3]>nacf_ap[2] && nacf_ap[4]>nacf_ap[3] &&
47 nacf_ap[4]>VOICEDTH && vER>-15 && E>2*Eprev)

```

3GPP2 C.S0014-C ver 1.0

```

1         m.speech_type=TRANSIENT;
2     }
3     break;
4     case VOICED:
5     default:
6         if (nacf_ap[2]>=LOWVOICEDTH) {
7             m.speech_type=VOICED;
8             if (nacf_ap[1]<LOWVOICEDTH || (nacf_ap[1]<VOICEDTH &&
9 nacf_ap[1]-nacf_ap[0]>0.3) || bER<0)
10                m.speech_type=TRANSIENT;
11                if (vER<-15 && nacf_ap[3]<LOWVOICEDTH && E<Eprev)
12                    m.speech_type=DOWN_TRANSIENT;
13                    if (bER<0 && vER<-20 && Enext<E && nacf_ap[3]<UNVOICEDTH &&
14 nacf_ap[4]<UNVOICEDTH)
15                        m.speech_type=UNVOICED;
16                        if (bER<-30 && E<Eprev)
17                            m.speech_type=UNVOICED;
18
19                            if ((nacf_ap[2]-nacf_ap[3]>0.3) && nacf_ap[3]<0.3 &&
20 nacf_ap[4]<0.25)
21                                m.speech_type=TRANSIENT;
22                            }
23                            else {
24                                if (bER>0) {
25                                    m.speech_type=TRANSIENT;
26                                    if (vER2<-15 && zcr<90 && E<Eprev && nacf_ap[3]<VOICEDTH)
27                                        m.speech_type=DOWN_TRANSIENT;
28                                        if (vER<-25 && E<Eprev)
29                                            m.speech_type=UNVOICED;
30                                    }
31                                    else {
32                                        m.speech_type=UNVOICED;
33                                        if (nacf_ap[3]>nacf_ap[2] && nacf_ap[4]>nacf_ap[3] && zcr<100
34 && vER>-20 && curr_ns_snr[0]>=SNR_THLD) // Clean condition
35                                            m.speech_type=TRANSIENT;
36                                            if (nacf_ap[3]>nacf_ap[2] && nacf_ap[4]>nacf_ap[3] && zcr<110
37 && vER>-15 && curr_ns_snr[0]<SNR_THLD) // Noisy condition
38                                                m.speech_type=TRANSIENT;
39                                                if (bER>-1 && vER>-12 && zcr<80)
40                                                    m.speech_type=TRANSIENT;
41                                                    if (bER>-3 && vER>-10 && nacf>UNVOICEDTH && zcr<90)
42                                                        m.speech_type=TRANSIENT;
43                                                        if (bER>-7 && vER>-3 && zcr<105 && curr_ns_snr[0]<SNR_THLD) //
44 Noisy condition
45                                                            m.speech_type=TRANSIENT;
46                                                            }

```

```

1
2         }
3
4         break;
5     }
6 }
7

```

#### 4.8.4 Rate-decision for SO 68 and SO 70

Depending on Input Operating Point, the mode-decision is first mapped to the different modes of the encoder at different rates as following according to the general rules shown in the following table.

**Table 4.8.4-1 Mapping of speech mode decision to encoding rate and mode**

Open Loop Mode decision	Mode and Rate used to encode the frame in SO 68 and SO 70 narrowband mode	Mode and Rate used to encode the frame in SO 70 wideband mode
Transient	Full-rate CELP	Full-rate CELP
Down Transient	Half-rate CELP or Full-rate CELP	Full-rate CELP
Uptransient	Full-rate CELP	Full-rate CELP
Voiced	FPPP, or QPPP, or FCELP processing Depending on the Operating Point, and a pre-determined pattern of interleaving QPPP with either FCELP or FPPP. A closed loop decision is later used in QPPP processing to achieve the input capacity operating point of EVRC-B.	Full-rate CELP.
Unvoiced	Quarter-rate NELP processing	Half-rate NELP processing
Silence	Eighth-rate processing	Eighth-rate processing

##### 4.8.4.1 Constraining Rate Selection

If the speech codec has been commanded to generate a Rate 1/2 maximum packet and the rate determined is Rate 1, it generates a Rate 1/2 CELP packet. If the speech codec has been requested to generate a Blank packet, it generates a packet based on the rate determined by the rate selection algorithm.

## 4.9 Quantization of LSP Parameters for SO 3

**Inputs:** The inputs to the LSP quantizer are:

- The unquantized LSPs for the current frame,  $\Omega(m)$
- The rate of the current frame,  $Rate(m)$

1 **Outputs:** The outputs from the LSP quantizer are:

- 2       • The quantized LSPs for the current frame,  $\Omega_q(m)$

3 **Processing:** The quantizer takes the form of a weighted split vector LSP quantizer. The splits for the quantizer  
 4 for a given *Rate* are given in parameter Table 4.9-1. All of the sub-matrices are coded using the number of bits  
 5 found in this table. The codebooks  $q_{rate}(k)$ , that are used to quantize each set of LSPs can be found in Table 9-1  
 6 through Table 9-9. Each LSP set has one codebook with dimensions  $n_{sub}(k)$  by  $n_{size}(k)$ .  $n_{sub}(k)$  is the number of  
 7 LSP parameters in the set and  $n_{size}(k)$  is the codebook size.

8

9

**Table 4.9-1 LSP Parameter Splits**

Codebook Number <i>k</i>	LSP Parameters in set $\Omega(m)$	LSP Split Starting Parameter Index <b>B(k)</b>	Number of LSP Parameters $n_{sub}(k)$	Code book Size $n_{size}(k)$	Number of bits allocated
<b>Rate 1</b>					
1	$\Omega(m, i); i \in (1, 2)$	1	2	64	6
2	$\Omega(m, i); i \in (3, 4)$	3	2	64	6
3	$\Omega(m, i); i \in (5, 6, 7)$	5	3	512	9
4	$\Omega(m, i); i \in (8, 9, 10)$	8	3	128	7
<b>Rate 1/2</b>					
1	$\Omega(m, i); i \in (1, 2, 3)$	1	3	128	7
2	$\Omega(m, i); i \in (4, 5, 6)$	4	3	128	7
3	$\Omega(m, i); i \in (7, \dots, 10)$	7	4	256	8
<b>Rate 1/8</b>					
1	$\Omega(m, i); i \in (1, \dots, 5)$	1	5	16	4
2	$\Omega(m, i); i \in (6, \dots, 10)$	6	5	16	4

10

11 The number of codebooks,  $k_{num}$ , for each rate is shown in Table 4.9-2.

12

Table 4.9-2 Number of LSP Codebooks

Rate	Number of Codebooks $k_{num}$
1	4
1/2	3
1/8	2

## 4.9.1 Computation of Weights

The weights,  $w(i)$ , for the LSP frequencies are defined as follows:

$$\omega(i) = \begin{cases} \frac{50}{2\pi} + 1 & ; \Delta_{\Omega}(m, i) = 0, \\ \frac{0.5}{2\pi\Delta_{\Omega}(m, i)} + 1 & ; \text{otherwise,} \end{cases} \quad 1 \leq i \leq 10, \quad (4.9.1-1)$$

where:

$$\Delta_{\Omega}(m, i) = \begin{cases} \Omega(m, i+1) - \Omega(m, i) & ; i=1, \\ \min((\Omega(m, i) - \Omega(m, i-1)), (\Omega(m, i+1) - \Omega(m, i))) & ; 2 \leq i \leq 9, \\ \Omega(m, i) - \Omega(m, i-1) & ; i=10. \end{cases} \quad (4.9.1-2)$$

## 4.9.2 Error Matrix Computation

Compute the error matrix,  $e(k)$ , for each set of LSP frequencies  $k$ :

$$e(k, j) = \sum_{i=1}^{n_{sub}(k)} \omega(B(k) + i - 1) (\Omega(m, B(k) + i - 1) - q_{rate}(k, i, j))^2 \quad ; 1 \leq j \leq n_{size}(k), \quad 1 \leq k \leq k_{num}, \quad (4.9.2-1)$$

where  $i$  is the sub-index of each LSP parameter set, and  $j$  is the index of the codebook entries. All the other parameters are defined in Table 4.9-1 and Table 4.9-2.

## 4.9.3 Adjustment of Quantization Error

The error associated between codebooks is adjusted to prevent excessively small (or negative) gaps between LSPs at codebook seams. If the difference between a particular  $q(k, l, j)$  and  $\Omega_q(m, B(k)-1)$  is less than  $\delta$ ,  $e(k, j)$  is assigned a value that will make it invalid for the search. The error matrix is adjusted by:

$$e(k, j) = \begin{cases} MAXFLOAT & ; (q_{rate}(k, l, j) - \Omega_q(m, B(k)-1)) \leq \delta, \\ e(k, j) & ; \text{otherwise,} \end{cases} \quad 1 \leq j \leq n_{size}(k), \quad 1 \leq k \leq k_{num} \quad (4.9.3-1)$$

where  $\delta = 0.05 / 2\pi$

1 4.9.4 Quantization Search

2 Each error matrix,  $e(k,i)$ , is searched for the minimum error,  $e_{min}(k)$ , as defined by:

3 
$$e_{min}(k) = \min\{e(k, j)MAXFLOAT\} ; 1 \leq j \leq n_{size}(k), 1 \leq k \leq k_{num} . \quad (4.9.4-1)$$

4 The codebook index to be transmitted,  $LSPIDX(k)$ , is defined as the index,  $j$ , where  $e_{min}(k)$  was found above for  
5 all  $k$ .

6 4.9.5 Generation of Quantized LSP Parameters

7 The codebook indices,  $LSPIDX(k)$ , are used to generate a quantized set of LSP parameters:

8 
$$\Omega_q(m, B(k) + i - 1) = q_{rate}(k, i, LSPIDX(k)) ; 1 \leq i \leq n_{sub}(k), 1 \leq k \leq k_{num} . \quad (4.9.5-1)$$

9 **4.10 Quantization of LSP Parameters for SO 68 and SO 70**

10 **Inputs**

11 The inputs to the LSP quantizer are:

12 The unquantized LSPs for the current frame,  $\Omega(m)$  (also referred to in this section as  $l$ )

13 The rate of the current frame,  $Rate(m)$

14 **Outputs**

15 The outputs from the LSP quantizer are:

16 The quantized LSPs for the current frame,  $\Omega_q(m)$

17 4.10.1 Full-rate, half-rate, and quarter-rate unvoiced: delta LSP VQ

18 For full-rate, half-rate, and quarter-rate unvoiced frames, a delta split LSPVQ scheme is used. The weights  
19 used in the error calculation in the LSPVQ are computed as:

20 
$$w(i) = \begin{cases} \frac{0.5}{2\pi\sqrt{(l(i) - l(i-1))(l(i+1) - l(i))}}; & 1 \leq i \leq 8 \\ \frac{0.5}{2\pi\sqrt{l(i)(l(i+1) - l(i))}}; & i = 0 \\ \frac{0.5}{2\pi\sqrt{(l(i) - l(i-1))(0.5)}}; & i = 9 \end{cases} \quad (4.10.1-1)$$

21 The delta split LSPVQ is in general represented by the following equation

$$k^* = \arg \max_k \sum_{i=i_l}^{i_u} \left[ \left( \frac{l(i)-ll}{lu-ll} - cb[k][i-i_l] \right)^2 w(i) \right]; \quad 0 \leq k < CBSIZE$$

(4.10.1-2)

with the following conditions

$$cb[k][0] = \max \left( cb[k][0], \frac{0.05}{2\pi(lu-ll)} \right)$$

(4.10.1-3)

$$cb[k][i_u - i_l - 1] = \min \left( cb[k][i_u - i_l - 1], 1 - \frac{0.05}{2\pi(lu-ll)} \right)$$

(4.10.1-4)

where,

$i_u$ , and  $i_l$  are the upper, and lower indices of the input LSP vector corresponding to a segment,

$lu$ , and  $ll$  are the lower and upper limit of the segment delta vector quantization.

$cb[x][y]$  is the code-vector corresponding to the xth entry in the code-book, and y is index of the element in the current split i.e  $il \leq y \leq lu$

CBSIZE is the size of the codebook for the current split

The dequantized LSP vector corresponding to the chosen index,  $k^*$ , for the split segment is given by

$$\hat{l}(i) = ll + (lu - ll)cb[k^*][i - i_l]; \quad i_l \leq i \leq i_u \quad (4.10.1-5)$$

with the following two conditioning on the end points of the split segment,

$$\hat{l}(i_l) = ll + \frac{0.05}{2\pi}; \quad \text{if } cb[k^*][0] < \frac{0.05}{2\pi(lu-ll)} \quad (4.10.1-6)$$

$$\hat{l}(i_u) = lu - \frac{0.05}{2\pi}; \quad \text{if } cb[k^*][i_u - i_l - 1] > 1 - \frac{0.05}{2\pi(lu-ll)}$$

(4.10.1-7)

#### 4.10.2 Full rate LSP and SO 70 Unvoiced Half Rate LSP VQ

Number of bits = 28.

The following table shows the parameters of the LSP VQ for full-rate and SO 70 unvoiced half-rate frames.

1 **Table 4.10.2-1 LSPVQ parameters for full- rate and SO 70 unvoiced half-rate**

Segment	$i_l$	$i_u$	$ll$	$lu$	# of elements in split	Elements	# of bits for the split	# of entries in quantization table
0	0	1	0	0.5	2	$l(0), l(1)$	6	64
1	2	3	$\hat{l}(1)$	$\hat{l}(4)$	2	$l(2), l(3)$	6	64
2	4	6	0	0.5	3	$l(4), l(5), l(6)$	9	512
3	7	9	$\hat{l}(6)$	0.5	3	$l(7), l(8), l(9)$	7	128

2

3 Segments 0, and 2 are quantized absolutely using  $ll = 0$ , and  $lu = 0.5$  first.

4 The quantization of segments 1 and 3 is performed using a multiple path approach where 4 best candidates (say  
 5 S0\_C0, S0\_C1, S0\_C2, S0\_C3 in decreasing order of optimality) are independently picked for segment 0, and 6  
 6 best candidates candidates (say S2\_C0, S2\_C1, S2\_C2, S2\_C3, S2\_C4, S2\_C5) are independently picked for  
 7 segment 2. The quantization of the split segments 1 and 3 depend on the candidates picked for segments 0 and  
 8 2. The search for the best candidates of segments 1 and 3 are performed for the pairs of candidates of segments  
 9 0 and 1 as shown in Table 4.10.2-2.

10

11 **Table 4.10.2-2 Multiple candidate search in full-rate and SO 70 unvoiced half-rate LSPVQ**

Segment 0 candidates in decreasing order of optimality	Number of top candidates of segment 2 used in search	Segment 2 candidates to be used in pair with segment 0 candidate
S0_C0	6	S2_C0, S2_C1, S2_C2, S2_C3, S2_C4, S2_C5
S0_C1	5	S2_C0, S2_C1, S2_C2, S2_C3, S2_C4
S0_C2	4	S2_C0, S2_C1, S2_C2, S2_C3
S0_C3	3	S2_C0, S2_C1, S2_C2

12

13 The basic idea is that the best candidate in Segment 0 are paired with all of the candidates of Segment 2, the  
 14 next best candidate of Segment 0 are paired with one less number of candidates of Segment 2 and so on.

15 For each pair of candidates of Segment 0, and Segment 2, the best candidate for Segments 1, and 3 are chosen  
 16 according the above equation above.

17 The final set of candidates (and their codebook indices) for all these segments is chosen as the one that  
 18 minimizes the following joint (10 dimensional going across segment split boundaries) error between the  
 19 unquantized LSP and the quantized LSP (obtained from independently selecting the best quantized vector for  
 20 the split segments).

$$e = \sum_{i=0}^9 w(i) (l(i) - \hat{l}(i))^2 \quad (4.10.2-1)$$

### 4.10.3 Half Rate LSPVQ for SO 68 and SO 70 NB Mode

Number of bits = 22.

The following table shows the parameters of the LSP VQ for half-rate frames.

**Table 4.10.3-1 LSPVQ parameters for half-rate**

Segment	$i_l$	$i_u$	$ll$	$lu$	# of elements in split	Elements	# of bits for the split	# of entries in quantization table
0	0	2	0	0.5	3	$l(0), l(1), l(2)$	7	128
1	3	5	$\hat{l}(2)$	$\hat{l}(6)$	3	$l(3), l(4), l(5)$	7	128
2	6	9	0	0.5	4	$l(6), l(7), l(8), l(9)$	8	256

Segments 0, and 2 are quantized absolutely using  $ll = 0$ , and  $lu = 0.5$  first.

The quantization of segment 1 is performed using a multiple path approach where 4 best candidates (say S0\_C0, S0\_C1, S0\_C2, S0\_C3 in decreasing order of optimality) are independently picked for segment 0, and 6 best candidates candidates (say S2\_C0, S2\_C1, S2\_C2, S2\_C3, S2\_C4, S2\_C5) are independently picked for segment 2. The quantization of the split segment 1 depends on the candidates picked for segments 0 and 2. The search for the best candidates of segments 1 is performed for the pairs of candidates of segments 0 and 1 as shown below in the table.

**Table 4.10.3-2 Multiple candidate search in half-rate LSPVQ**

Segment 0 candidates in Decreasing order of optimality	Number of top candidates of Segment 2 used in search	Segment 2 candidates to be used in pair with Segment 0 candidate
S0_C0	6	S2_C0, S2_C1, S2_C2, S2_C3, S2_C4, S2_C5
S0_C1	5	S2_C0, S2_C1, S2_C2, S2_C3, S2_C4
S0_C2	4	S2_C0, S2_C1, S2_C2, S2_C3
S0_C3	3	S2_C0, S2_C1, S2_C2

1 The basic idea is that the best candidate in Segment 0 are paired with all of the candidates of Segment 2, the  
 2 next best candidate of Segment 0 are paired with one less number of candidates of Segment 2 and so on.

3 For each pair of candidates of Segment 0, and Segment 2, the best candidate for Segments 1 is chosen  
 4 according the above equation.

5 The final set of candidates (and their codebook indices) for all these segments is chosen as the one that  
 6 minimizes the following joint (10 dimensional going across segment split boundaries) error between the  
 7 unquantized LSP and the quantized LSP (obtained from independently selecting the best quantized vector for  
 8 the split segments).

$$e = \sum_{i=0}^9 w(i) (l(i) - \hat{l}(i))^2 \quad (4.10.3-1)$$

10 4.10.4 Quarter rate unvoiced LSPVQ for SO 68

11 Number of bits = 16.

12 The following table shows the parameters of the LSP VQ for quarter-rate unvoiced frames.

13  
 14 **Table 4.10.4-1 LSPVQ parameters for quarter-rate unvoiced**

Segment t	$i_l$	$i_u$	$ll$	$lu$	# of elements in split	Elements	# of bits for the split	# of entries in quantization table
0	0	4	0	$\hat{l}(5)$	5	$l(0), l(1), l(2),$ $l(3), l(4)$	8	256
1	5	9	0	0.5	5	$l(5), l(6),$ $l(7), l(8), l(9)$	8	256

15  
 16 Segment 1 is quantized absolutely using  $ll = 0$ , and  $lu = 0.5$  first.

17 The quantization of segment 0 is performed using a multiple path approach where 6 best candidates (say  
 18 S1\_C0, S1\_C1, S1\_C2, S1\_C3, S1\_C4, S1\_C5) are independently picked for segment 1. The quantization of  
 19 the split segment 0 depends on the candidates picked for segment 1. The search for the best candidates of  
 20 segment 0 is performed for each of the 6 candidates of segment 1 using the above equation.

21 The final set of candidates (and their codebook indices) for all these segments is chosen as the one that  
 22 minimizes the following joint (10 dimensional going across segment split boundaries) error between the  
 23 unquantized LSP and the quantized LSP (obtained from independently selecting the best quantized vector for  
 24 the split segments).

$$e = \sum_{i=0}^9 w(i) (l(i) - \hat{l}(i))^2 \quad (4.10.4-1)$$

## 1 4.10.5 Quarter-rate Voiced LSPVQ for SO 68

2 A second order moving average (MA) predictor is used for quantizing the LSPs in quarter-rate voiced frame  
3 processing.

## 4 4.10.5.1 QPPP LSP quantization Weight Computation

5 The weights described in Section 4.10.1 are used to compute the weighted square error distortion metrics  
6 needed to search the LSP VQ codebooks in the QPPP LSP VQ procedure described in this section.

7 The MA predictive quantizer ensures that the effect of frame errors discontinues after 2 frames. The quantized  
8 LSP vector at the  $m$ th frame is given as

$$9 \quad \hat{\mathbf{L}}_{im} = 0.4\mathbf{C}_m + 0.4\mathbf{C}_{m-1} + 0.2\mathbf{C}_{m-2} \quad (4.10.5-1)$$

10 where  $\mathbf{C}_m$  is the codebook vector for the  $m$ th frame, and  $\hat{\mathbf{L}}_{im}$  is the vector representation of the quantized LSP  
11 vector denoted by  $\hat{l}_i$ . The target vector  $\mathbf{U}_m$  to the quantizer is constructed using the input unquantized LSP  
12 vector  $\mathbf{L}_{im}$ , and the past codebook vectors as

$$13 \quad \mathbf{U}_m = \frac{\mathbf{L}_{im} - 0.4\mathbf{C}_{m-1} - 0.2\mathbf{C}_{m-2}}{0.4} \quad (4.10.5-2)$$

14 A regular 16-bit split VQ structure (with weighted MSE as the selection criterion) is used to encode the first 6  
15 elements of the target vector  $\mathbf{U}_m$  with a 10-bit codebook and the last 4 elements using 6 bits. Let  $i_1^*$  and  $i_2^*$  be  
16 the chosen best indices out of the split VQ for the two splits. The quantizer output  $\mathbf{C}_m$  is constructed as  
17 follows:

$$18 \quad \mathbf{C}_m(i) = \begin{cases} CB1[i_1^*][i]; & 0 \leq i < 6 \\ CB2[i_2^*][i-6]; & 6 \leq i < 10 \end{cases} \quad (4.10.5-3)$$

## 19 4.10.5.2 Constructing the MAVQ memory during frames that are not QPPP

20 During frames that are not QPPP, a MAVQ scheme is not used. Therefore, it is essential to construct the  
21 MAVQ memory elements,  $\mathbf{C}_{m-1}$  and  $\mathbf{C}_{m-2}$ , as follows:

$$22 \quad \mathbf{C}_{m-1} = \mathbf{C}_{m-1} = \hat{\mathbf{L}}_{im}$$

23 where the vector  $\hat{\mathbf{L}}_{im}$  is the the quantized LSPs,  $\hat{l}_i$ .

4.10.6 Eighth-rate LSPVQ for SO 68 and SO 70 NB mode

The eighth-rate LSPVQ for SO 68 and SO 70 NB mode is the same as that for SO 3 and described in Section 4.9.

4.10.7 Eighth-rate LSPVQ SO 70 WB mode

Number of bits = 10.

The following table shows the parameters of the LSP VQ for eighth rate SO 70 WB mode frames.

**Table 4.10.7-1 LSPVQ parameters for eighth rate SO 70 WB mode**

Segment	$i_l$	$i_u$	$ll$	$lu$	# of elements in split	Elements	# of bits for the split	# of entries in quantization table
0	0	4	0	0.5	5	$l(0), l(1), l(2), l(3), l(4)$	5	32
1	5	9	$\hat{l}(4)$	0.5	5	$l(5), l(6), l(7), l(8), l(9)$	5	32

Segment 0 is quantized absolutely using  $ll = 0$ , and  $lu = 0.5$  first.

The quantization of segment 0 is performed using a multiple path approach where 6 best candidates (say S1\_C0, S1\_C1, S1\_C2, S1\_C3, S1\_C4, S1\_C5) are independently picked for segment 0. The quantization of the split segment 1 depends on the candidates picked for segment 0. The search for the best candidates of segment 1 is performed for each of the 6 candidates of segment 0 using the above equation.

The final set of candidates (and their codebook indices) for all these segments is chosen as the one that minimizes the following joint (10 dimensional going across segment split boundaries) error between the unquantized LSP and the quantized LSP (obtained from independently selecting the best quantized vector for the split segments).

$$e = \sum_{i=0}^9 w(i) (l(i) - \hat{l}(i))^2 \tag{4.10.7-1}$$

**4.11 Encoding at Rates 1/2 and 1 for SO 3, SO 68, and SO 70**

The algorithm for encoding at Rate 1 is similar to that used for encoding at Rate 1/2 except for the quantization tables used and the fact that certain quantities (e.g., the spectral transition indicator, *LPCFLAG*, and the delay difference, *DDELAY*) are transmitted only at Rate 1. Encoding is accomplished as follows:

**Inputs:** The inputs to encoding are:

- The quantized LSPs from the previous frame,  $\Omega_q(m-1)$

- 1           • The unquantized LSPs from the current and previous frames,  $\Omega(m)$  and  $\Omega(m-1)$
- 2           • The short-term prediction residual,  $\varepsilon(n)$
- 3           • The pitch delay estimate for the previous frame,  $\tau(m-1)$
- 4           • The pitch delay estimate for the current frame,  $\tau(m)$
- 5           • The long term prediction gain,  $\beta$
- 6           • The rate of the current frame,  $Rate(m)$

7   **Outputs:** The outputs of encoding are:

- 8           • The quantized LSPs for the current frame,  $\Omega_q(m)$
- 9           • The LSP indices corresponding to the quantized LSPs,  $LSPIDX(k)$
- 10          • The adaptive codebook gain index,  $ACBGIDX(m')$ , for each subframe,  $m'$
- 11          • The fixed codebook shape indices,  $FCBSIDX(m')$ , for each subframe,  $m'$
- 12          • The fixed codebook gain indices,  $FCBGIDX(m',k)$ , for each subframe,  $m'$
- 13          • The delay transmission code,  $DELAY$
- 14          • The spectral transition indicator,  $LPCFLAG$  (SO 3, Rate 1 only)
- 15          • The delay difference,  $DDELAY$  (SO 3, Rate 1 only)
- 16          • The residual energy index,  $RESEIDX$  (SO 70, WB mode only)
- 17          • The composite index  $K$ , which comprises the codebook configuration parameter  $C_p$ , the closed loop delay adjustment indices  $DELAY\_ADJ\_INX(m')$ , and the fixed codebook gain indices,  $FCBGIDX(m',k)$ , for each subframe,  $m'$  (SO 70, WB mode only)

20 **State Variables Affected:**

- 21          • The adaptive codebook excitation signal,  $E(n)$
- 22          • The accumulated shift counter,  $\tau_{acc}$
- 23          • The pointer to the last sample in the shifted residual,  $n_m$
- 24          • The state of the shifted residual buffer,  $shiftstate$
- 25          • The filter memories in  $H_{wq}(z)$  and  $H_w(z)$
- 26          • The modified residual buffer,  $\hat{\varepsilon}(n)$

27 **Initialization:**

- 28          • The state of the shifted residual buffer,  $shiftstate = CENTER$
- 29          • The quantized LSPs,  $\Omega_q(m,k) = 0.048k$ ,  $m = 0$ ,  $1 \leq k \leq 10$

30 **Processing:**

31 EVRC encoding shall comprise the procedures described in 4.11.1 through 4.11.8. A block diagram of the  
32 RCELP encoding process is shown in Figure 4.11-1.

33

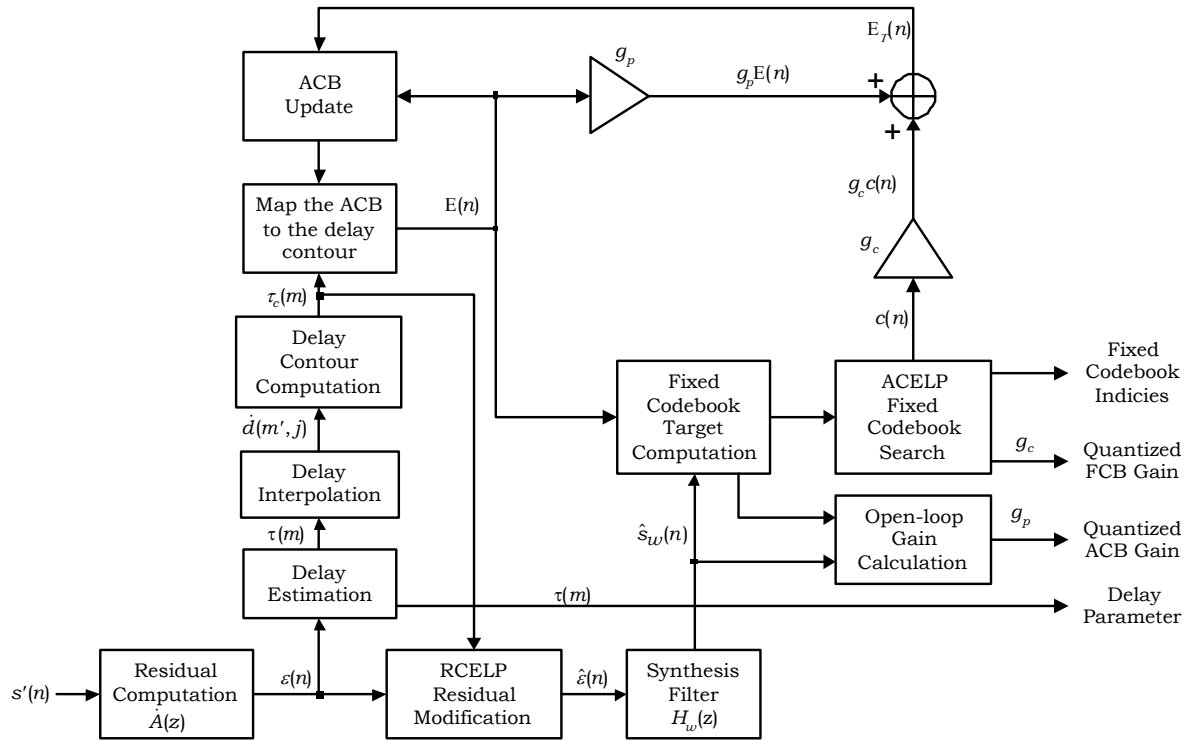

Figure 4.11-1 RCELP Encoding Block Diagram

4.11.1 LSP Quantization

The encoder shall vector quantize the unquantized LSPs,  $\Omega(m)$ , using the procedure found in 4.9 for Rates 1 or 1/2.

4.11.2 RCELP Shift State Update

The encoder shall update the shift state with hysteresis and control the accumulated shift. This step prevents the asynchrony between the original signals and the modified signals from increasing over time. It shall be implemented as a state machine, given by:

```

/* if signal is not at all periodic, reset */
if (  $\beta < 0.1$  ) {
     $\tau_{acc} = 0$ 
     $n_m = 0$ 
     $shiftstate = CENTER$ 
}

/* update shift state with hysteresis */
if (  $\tau_{acc} > 20$  ) {
     $shiftstate = RIGHT$ 
}
if (  $\tau_{acc} < -20$  ) {
     $shiftstate = LEFT$ 
}

```

```

1      }
2      if (  $\tau_{acc} \leq 10$  &&  $shiftstate = RIGHT$  ) {
3           $shiftstate = CENTER$ 
4      }
5      if (  $\tau_{acc} \geq -10$  &&  $shiftstate = LEFT$  ) {
6           $shiftstate = CENTER$ 
7      }
8      /* control accumulated shift by adjusting the delay */
9      if (  $shiftstate == LEFT$  &&  $\beta < 0.4$  ) {
10          $\tau(m) = \tau(m) + 1$ 
11     }
12     else if (  $shiftstate == RIGHT$  &&  $\beta < 0.4$  ) {
13          $\tau(m) = \tau(m) - 1$ 
14     }
15     /* check to keep delay within bounds */
16      $\tau(m) = \min\{ \tau(m), 120 \}$ 
17      $\tau(m) = \max\{ \tau(m), 20 \}$ 

```

#### 18 4.11.3 Delay Encoding

19 The delay parameter,  $\tau(m)$ , determined in 4.6.3, shall be encoded for transmission by:

$$20 \quad DELAY = \tau(m) - \tau_{min}, \quad (4.11.3-1)$$

21 where  $\tau_{min}=20$ .

22 In Rate 1 processing only, a differential delay parameter shall be transmitted for use in reconstructing the delay  
23 contour in the decoder after frame erasures. The transmission code,  $DDELAY$ , is defined as:

$$24 \quad DDELAY = \begin{cases} 0 & ;|\Delta_{\tau}| > 15, \\ \Delta_{\tau} + 16 & ;\text{otherwise} \end{cases} \quad (4.11.3-2)$$

25 where

$$26 \quad \Delta_{\tau} = \tau(m) - \tau(m-1). \quad (4.11.3-3)$$

#### 27 4.11.4 Rates 1/2 and 1 Subframe Processing

28 The procedures described in 4.11.4.1 through 4.11.4.15 shall be carried out for three subframes,  $0 \leq m' < 3$ .  
29 The subframe size,  $L$ , is 53 for subframes 0 and 1, and 54 for subframe 2.

##### 30 4.11.4.1 Interpolation of LSP Parameters

31 Interpolate the unquantized and quantized LSPs over the three subframes,  $m'$ , in the current frame,  $m$ . The  
32 form of the unquantized, interpolated LSP vector for subframe  $m'$  is given by:

$$33 \quad \Omega(m') = (1 - \mu_{m'})\Omega(m-1) + \mu_{m'}\Omega(m), \quad (4.11.4-1)$$

1 and form of the quantized, interpolated LSP vector is given by:

$$2 \quad \Omega_q(m') = (1 - \mu_{m'})\Omega_q(m-1) + \mu_{m'}\Omega_q(m), \quad (4.11.4-2)$$

3 where the subframe interpolator constants are defined as  $\mu = \{ 0.1667, 0.5, 0.8333 \}$ .

#### 4 4.11.4.2 LSP to LPC Conversion

5 Convert the unquantized, interpolated LSPs,  $\Omega(m')$ , to unquantized, interpolated LPC parameters,  $\{\hat{a}\}$ , as  
6 described in 4.6.2.2 for each subframe. Convert the quantized, interpolated LSPs,  $\Omega_q(m')$ , to quantized,  
7 interpolated LPC parameters,  $\{\hat{a}_q\}$ , as described in 4.6.2.2, using the quantized LSPs at the end-points instead  
8 of the unquantized LSPs.

#### 9 4.11.4.3 Interpolated Delay Estimate Calculation\*

10 Calculate a set of three interpolated delay estimates,  $\hat{d}(m', j)$ , for each subframe  $m'$  as follows:

$$11 \quad \hat{d}(m', j) = \begin{cases} \tau(m) & ; |\tau(m) - \tau(m-1)| > 15, \\ (1 - f(m' + j))\tau(m-1) + f(m' + j)\tau(m) & ; \text{otherwise,} \end{cases} \quad 0 \leq m' < 3, 0 \leq j < 3, \quad (4.11.4-3)$$

12 where  $m$  is the current frame,  $m'$  is the subframe index, and  $m' + j$  is an index into an array of interpolator  
13 coefficients,  $f$ , defined by:

$$14 \quad f = \{ 0.0, 0.3313, 0.6625, 1.0, 1.0 \}. \quad (4.11.4-4)$$

#### 15 4.11.4.4 Modification of the Original Residual

16 Generate a modified residual signal,  $\hat{\varepsilon}(n)$ , by shifting the current residual signal,  $\varepsilon(n)$ , to match the delay  
17 contour for the current subframe. See 0 for details on this operation.

#### 18 4.11.4.5 Generation of the Weighted Modified Original Speech Vector

19 Generate the weighted modified original speech vector,  $\hat{s}_w(n)$ , by filtering the modified residual,  $\hat{\varepsilon}(n)$ , through  
20 the weighted synthesis filter  $H_w(z)$ . For narrowband (8 kHz sampled) inputs,  $H_w(z)$  is given by:

$$21 \quad H_w(z) = \frac{1}{A(z)} \left[ \frac{A(\gamma_1^{-1}z)}{A(\gamma_2^{-1}z)} \right], \quad (4.11.4-5)$$

22 where

$$1 \quad A(z) = 1 - \sum_{k=1}^{10} a(k)z^{-k}, \quad (4.11.4-6)$$

2 and

$$3 \quad A(\gamma_l^{-1}z) = 1 - \sum_{k=1}^{10} a(k)\gamma_l^k z^{-k} \quad ; l=1,2, \quad (4.11.4-7)$$

4 where  $\gamma_1 = 0.9, \gamma_2 = 0.5$ .

5 The weighted synthesis filter for wideband (16 kHz sampled) inputs includes harmonic noise weighting  
6 (HNW), which overcomes some of the limitations of low rate coding [R14]. HNW efficiently utilizes noise-  
7 masking properties by exploiting the speech signal's harmonic structure. The HNW filter is given by:

$$8 \quad C(z) = 1 - \varepsilon_p g'_p z^{-\tau'} \quad (4.11.4-8)$$

9 where  $\tau' = (d(m',0) + d(m',1))/2$  is the average subframe delay (sec 4.11.4.3), and  $\varepsilon_p$  is the HNW coefficient  
10 given as a decreasing function of the average subframe delay as:

$$11 \quad \varepsilon_p = \begin{cases} \varepsilon_{\min}, & \tau' \geq \tau'_{\max} \\ \varepsilon_{\min} + \Delta \frac{(\tau'_{\max} - \tau')}{\tau'_{\max}}, & \tau' \geq \left(1 - \frac{\varepsilon_{\max} - \varepsilon_{\min}}{\Delta}\right) \tau'_{\max} \\ \varepsilon_{\max}, & \text{otherwise} \end{cases} \quad (4.11.4-9)$$

12 where  $\varepsilon_{\max} = 0.6$  is the maximum allowable value of the HNW coefficient,  $\varepsilon_{\min} = 0$  is the minimum allowable  
13 value of the HNW coefficient,  $\tau'_{\max} = 110$  is the maximum pitch delay above which HNW coefficient is set to  
14  $\varepsilon_{\min}$ , and  $\Delta = 1.1$  is the slope for the HNW coefficient. The HNW gain  $g'_p$  is found by:

$$15 \quad g'_p = \frac{\sum_{n=0}^{L-1} \hat{s}_{sw}(n) \hat{s}_{sw}(n - \tau')}{\sum_{n=0}^{L-1} \hat{s}_{sw}^2(n)}, \quad (4.11.4-10)$$

16 where  $0 \leq g'_p \leq 1.0$ , and  $\hat{s}_{sw}(n)$  is the spectrally weighted modified speech which is obtained by filtering the  
17 modified residual  $\hat{\varepsilon}(n)$  through the spectral weighting filter given by:

$$18 \quad H_{sw}(z) = \frac{1}{A(z)} \left[ \frac{A(\gamma_1^{-1}z)}{1 - \mu z^{-1}} \right], \quad (4.11.4-11)$$

19 where  $\gamma_1 = 0.9$  and  $\mu = 0.48$  is the tilt coefficient. The signal  $\hat{s}_w(n)$  is finally obtained by filtering  $\hat{s}_{sw}(n)$   
20 through the composite HNW filter  $C(z)$ . To generate the fractional pitch delay  $z^{-\tau'}$  part of the HNW filter, an  
21 interpolation is performed using an 8x oversampled FIR low pass filter with a windowed sinc function  
22 truncated at  $\pm 31$  and a cut-off frequency at approximately 1000 Hz.

1 4.11.4.6 Zero Input Response Calculation

2 Calculate the zero-input response,  $a_{zir}(n)$ , of the weighted synthesis filter,  $H_{wq}(z)$ . The weighted synthesis filter  
3  $H_{wq}(z)$  for narrowband (8 kHz sampled) inputs is defined as:

$$4 \quad H_{wq}(z) = \frac{1}{A_q(z)} \left[ \frac{A(\gamma_1^{-1}z)}{A(\gamma_2^{-1}z)} \right] \quad (4.11.4-12)$$

5 where

$$6 \quad A_q(z) = 1 - \sum_{k=1}^{10} a_q(k)z^{-k}, \quad (4.11.4-13)$$

7 and other symbols are previously defined. The weighted synthesis filter for wideband (16 kHz sampled) inputs  
8 is given by:

$$9 \quad H_{wq}(z) = \frac{1}{A_q(z)} \left[ \frac{A(\gamma_1^{-1}z)}{1 - \mu z^{-1}} C(z) \right], \quad (4.11.4-14)$$

10 where all symbols have been previously defined.

11 Then subtract the zero-input response,  $a_{zir}(n)$ , of the weighted synthesis filter,  $H_{wq}(z)$ , from the weighted  
12 modified original speech vector,  $\hat{s}_w(n)$  to produce the weighted target speech vector:

$$13 \quad \hat{s}_w(n) = \hat{s}_w(n) - a_{zir}(n) \quad ; 0 \leq n < L. \quad (4.11.4-15)$$

14 4.11.4.7 Impulse Response Calculation

15 Calculate the impulse response,  $h_{wq}(n)$ , of the weighted synthesis filter,  $H_{wq}(z)$ , to 54 terms.

16 4.11.4.8 Calculation of the Adaptive Codebook Contribution

17 Compute the adaptive codebook contribution,  $E(n)$ , the filtered adaptive codebook contribution,  $\lambda(n)$ , and the  
18 unquantized ACB gain,  $g_{p\_unq}$ , described in 4.11.5. For SO 70 in wideband operation, the interpolated delay  
19 estimates  $\hat{d}(m', j)$  may be modified to reflect closed loop delay contour adjustment, in which case, the  
20 codebook configuration parameter  $C_p$  will be set, and the delay adjustment indices will be contained in  
21  $DELAY\_ADJ\_INX(m')$ .

22 4.11.4.9 Closed-Loop Gain Calculation

23 The closed-loop quantized gain,  $g_p$ , is calculated by first determining the cross-correlation,  $R_{s\lambda}(0)$ , of  $\hat{s}_w(n)$   
24 and  $\lambda(n)$ :

$$25 \quad R_{s\lambda}(0) = \sum_{n=0}^{L-1} \hat{s}_w(n)\lambda(n), \quad (4.11.4-16)$$

26 the auto-correlation of  $\lambda(n)$  is then calculated by:

$$R_{\lambda\lambda}(0) = \sum_{n=0}^{L-1} \lambda^2(n). \quad (4.11.4-17)$$

The quantized closed loop gain,  $g_p$ , is defined by:

$$g_p = \begin{cases} g_{pcb}(0) & ; R_{s\lambda}(0) \leq 0, \\ g_{pcb}(ACBGIDX(m')) & ; R_{s\lambda}(0) > 0, \end{cases} \quad (4.11.4-18)$$

where  $g_{pcb}(k)$  is an entry in the adaptive codebook gain quantization Table 4.11.4.9-1, and  $ACBGIDX(m')$  is the optimal index into  $g_{pcb}(k)$  calculated by:

$$\begin{aligned} & ACBGIDX(m') = 0 \\ & \text{for } (k = 1; k < g_{pcb\_size}; k = k + 1) \{ \\ & \quad \text{if } \left( R_{s\lambda}(0) > \left( \frac{g_{pcb}(k) + g_{pcb}(k-1)}{2} R_{\lambda\lambda}(0) \right) \right) \{ \\ & \quad \quad ACBGIDX(m') = k \\ & \quad \} \\ & \} \end{aligned}$$

where  $g_{pcb\_size} = 8$ .

**Table 4.11.4.9-1 Adaptive Codebook Gain Quantization Table**

$k$	$g_{pcb}(k)$
0	0.00
1	0.30
2	0.55
3	0.70
4	0.80
5	0.90
6	1.00
7	1.20

#### 4.11.4.10 Fixed Codebook Search Target Vector Generation

##### 4.11.4.10.1 Perceptual Domain Target Vector

For SO 3, SO 68, and SO 70 narrowband interoperability mode, calculate the target vector in the perceptual domain,  $x_w(n)$ , defined by:

$$x_w(n) = \hat{s}_w(n) - g_p \lambda(n) \quad ; 0 \leq n < L, \quad (4.11.4-19)$$

where  $\hat{s}_w(n)$  and  $\lambda(n)$  are defined in 4.5.4.9. For SO 70 wideband mode, calculate the target vector in the perceptual domain,  $x_w(n)$ , as:

$$x_w(n) = \begin{cases} \hat{s}_w(n) - g_p \lambda(n) & ; \dot{\tau} < L \\ \hat{s}_w(n) - g_{p\_unq} \lambda(n) & ; \dot{\tau} \geq L \end{cases}, \quad 0 \leq n < L, \quad (4.11.4-20)$$

where  $\dot{\tau}$  is the average subframe delay given in Equation 4.11.4-22.

The unquantized ACB gain  $g_{p\_unq}$  is used in cases where the joint optimization of ACB/FCB gains is performed (see 4.11.8.2)

#### 4.11.4.10.2 Conversion of the Target Vector to the Residual Domain

For SO 3, SO 68, and SO 70 narrowband interoperability mode, convert the target vector from the perceptual domain to the residual domain by filtering  $x_w(n)$  through the zero-state inverse of the weighting filter,  $H_{wq}(z)$ :

$$H_{wq}^{-1}(z) = A_q(z) \frac{A(\gamma_2^{-1}z)}{A(\gamma_1^{-1}z)}, \quad (4.11.4-21)$$

and all other terms are defined in 4.11.4.3.

The resulting target vector in the residual domain is defined as  $x(n)$ .

#### 4.11.4.10.3 Delay Calculation for Current Subframe

The fixed codebook search requires an estimate of the delay,  $\dot{\tau}$ , for the current subframe, defined by:

$$\dot{\tau} = \text{round} \left\{ \frac{\dot{d}(m', 0) + \dot{d}(m', 1)}{2} \right\}, \quad (4.11.4-22)$$

where  $\dot{d}(m', j)$  is defined in 4.11.4.3.

#### 4.11.4.11 Fixed Codebook Search

Perform the fixed codebook search as described in 4.11.7.

#### 4.11.4.12 Fixed codebook gain quantization

The fixed codebook gain,  $g_c$ , computed in 4.11.4.11, is constrained by:

$$g_c = \begin{cases} (1.0 - 0.15g_p)g_c & ;\text{Rate}(m)=\text{Rate}1, \\ (0.9 - 0.1g_p)g_c & ;\text{Rate}(m)=\text{Rate}1/2, \end{cases} \quad (4.11.4-23)$$

which is then quantized (for SO 3, SO 68, and SO 70 narrowband interoperability mode) by the following process:

$$\begin{aligned} &FCBGIDX(m') = 0 \\ &\text{for } (k = 1; k < g_{ccb\_size}; k = k + 1) \\ &\quad \text{if } \left( g_c > \left( \frac{g_{ccb}(k) + g_{ccb}(k-1)}{2} \right) \right) \{ \\ &\quad \quad FCBGIDX(m') = k \\ &\quad \} \\ &g_c = g_{ccb}(FCBGIDX(m')) \end{aligned}$$

where  $g_{ccb}(k)$  is a fixed codebook gain quantization entry defined in Table 9-15 and Table 9-16 for Rate 1 and Rate 1/2, respectively, and  $FCBGIDX(m')$  is the optimal index into the appropriate table for each subframe  $m'$ .

For SO 70 wideband mode, the FCB gain is quantized using the residual energy of the current frame as a first order prediction estimate of the FCB gain. The prediction error for each subframe is then quantized according to a minimum mean squared error criteria. The residual energy for the current frame is calculated as:

$$E_r = \sqrt{\sum_{n=80}^{239} \varepsilon^2(n)}, \quad (4.11.4-24)$$

which is then quantized using 3 bits according to the following expression:

$$E_{rq} = \exp\left(\min_{i \in \{0, \dots, 7\}} \left( \ln(E_r) - (4.0 + 7.5i/8.0) \right)^2\right), \quad (4.11.4-25)$$

and where  $RESEIDX = i$  is the index corresponding the minimum log domain distortion. The FCB gain is then given by:

$$g_c = g_{ccb2}(FCBGIDX(m'))E_{rq} \sqrt{\frac{1 - g_p^2/3}{\sum_{i=0}^{L-1} c_k^2(i)}}, \quad (4.11.4-26)$$

where  $c_k$  is the FCB excitation vector,  $g_p$  is the quantized ACB gain from Table 4.11.4.9-1, and  $g_{ccb2}(i)$  is the  $i$ -th quantized FCB correction factor, as defined by the 16 element lookup table:

$$g_{ccb2} = \{0.0251, 0.0321, 0.0410, 0.0524, 0.0671, 0.0857, 0.1096, 0.1401, \\ 0.1791, 0.2290, 0.2928, 0.3743, 0.4786, 0.6118, 0.7822, 1.0000\}. \quad (4.11.4-27)$$

From the given error expression  $e(n) = \hat{s}_w(n) - g_p \lambda(n) - g_c y_2(n)$ , where  $y_2(n) = h_{wq}(n) * c_k(n)$  is the filtered FCB excitation, the optimal FCB/ACB gains are determined by solving for the minimum squared error, according to the following expression:

$$\min \left\{ \hat{\mathbf{s}}_w^t \hat{\mathbf{s}}_w - 2g_p \hat{\mathbf{s}}_w^t \boldsymbol{\lambda} - 2g_c \hat{\mathbf{s}}_w^t \mathbf{y}_2 - 2g_p g_c \boldsymbol{\lambda}^t \mathbf{y}_2 + g_p^2 \boldsymbol{\lambda}^t \boldsymbol{\lambda} + g_c^2 \mathbf{y}_2^t \mathbf{y}_2 \right\}. \quad (4.11.4-28)$$

For cases when pitch sharpening is not active (i.e.,  $\hat{\tau} \geq L$ ), all possible values  $g_p$  and  $g_c$  (Table 4.11.4.9-1 and Equation 4.11.4-26 respectively) are evaluated to produce the minimum distortion. For cases when pitch sharpening is active (i.e.,  $\hat{\tau} < L$ ), the ACB gain  $g_p$  has already been quantized, and only the terms containing the FCB gain  $g_c$  are required to be calculated.

#### 4.11.4.13 Combined Excitation Vector Computation

The combined excitation vector,  $E_T(n)$ , for the current subframe,  $m'$  is defined as the sum of the adaptive codebook contribution,  $E(n)$ , and the fixed codebook contribution,  $c(n)$ :

$$E_T(n) = g_p E(n) + g_c c(n) \quad ; 0 \leq n < L. \quad (4.11.4-29)$$

#### 4.11.4.14 Excitation Input to Highband Analysis (SO 70 wideband mode)

The combined excitation vector,  $E_T(n)$ , for the current subframe,  $m'$  is filtered through a pitch enhancement filter prior to input to highband analysis in 4.18. The pitch enhancement filter is a time varying filter of the form:

$$P(z, n) = \frac{1}{1 - 0.4g_p z^{-\tau_c(n)}}; \quad 0 \leq n < L, \quad (4.11.4-30)$$

where  $\tau_c(n)$  is the delay contour obtained from interpolating the delay adjusted endpoints,  $\hat{d}(m', 0)$  to  $\hat{d}(m', 1)$ , as in 4.11.5.1. The filter uses an 8x oversampling fractional pitch interpolation similar to that used for generating the adaptive codebook contribution. This notation, however, is a mix of time domain and  $z$ -transform symbols, where the  $z^{-1}$  operator is to be viewed as a unit delay operator rather than a  $z$ -transform. The state of this filter is reset to all zeros on subframe  $m' = 0$  when the previous frame was not RCELP Rate 1 or Rate  $\frac{1}{2}$ . In addition, the energy of the output of the pitch enhancement filter is normalized to the input energy.

#### 4.11.4.15 Encoder State Variable Update

Update the weighted synthesis filter memory by filtering the combined excitation vector,  $E_T(n)$ , through the weighted synthesis filter,  $H_{wq}(z)$ , which is given in Equation 4.11.4-12.

Update the modified residual memory by copying  $n_m$  elements of the current modified residual to the beginning of the modified residual buffer:

$$\hat{\mathbf{e}}(n) = \hat{\mathbf{e}}(n+L); \quad 0 \leq n < n_m. \quad (4.11.4-31)$$

Update the excitation memory for the adaptive codebook with the combined excitation for the current subframe:

$$E(n) = \begin{cases} E(n+L) & ; -128 \leq n < -L \\ E_T(n+L) & ; -L \leq n < 0 \end{cases} \quad (4.11.4-32)$$

1 Conditionally reset the accumulated shift counter,  $\tau_{acc}$ , and the pointer to the last sample in the shifted residual,  
2  $n_m$ , according to the following:

3 if  $\left( \left( \sum_{i=0}^2 ACBGIDX(i) \leq 1 \right) \text{and} (ACBGIDX(2) \neq 1) \right) \{$   
4  $\quad \tau_{acc} = 0$   
5  $\quad n_m = 0$   
6  $\quad \}$

#### 7 4.11.5 Computation of the Adaptive Codebook Contribution

8 **Inputs:** The inputs to the adaptive codebook computation are:

- 9 • The vector of interpolated delays,  $\hat{d}(m', j)$ , calculated in 4.11.4.3
- 10 • The current subframe number,  $m'$
- 11 • The current subframe size,  $L$

12 And for SO 70 wideband inputs:

- 13 • The weighted target speech vector,  $\hat{s}_w(n)$
- 14 • The open loop delay estimates for the current and previous frames,  $\tau(m)$  and  $\tau(m-1)$ , respectively

15 **Outputs:**

- 16 • The adaptive codebook excitation,  $E(n)$ , where  $-128 \leq n \leq 64$
- 17 • The filtered adaptive codebook excitation,  $\lambda(n)$

18 And for SO 70 wideband inputs:

- 19 • The codebook configuration parameter  $C_p$
- 20 • The closed loop delay adjustment indices,  $DELAY\_ADJ\_INX(m')$
- 21 • The adjusted vector of interpolated delay endpoints,  $\hat{d}(m', j)$
- 22 • The unquantized constrained optimum ACB gain,  $g_{p\_unq}$

23 **Initialization:** The variables used in the computation of the adaptive codebook contribution are initialized as  
24 follows:

- 25 • The adaptive codebook excitation memory,  $E(n) = 0$ ;  $-128 \leq n \leq 64$

26 **Processing:**

27 Computation of the adaptive codebook contribution for SO 3, SO 68, and SO 70 narrowband interoperability  
28 mode shall be performed according to the procedures described in 4.11.5.1 and 4.11.5.3. For SO 70, wideband  
29 mode, a second adaptive codebook is added that performs closed loop delay contour adjustment. A codebook  
30 configuration parameter  $C_p$  is used to indicate which of 2 ACB/FCB combinations is active, and if the delay  
31 contour adjustment ACB is used, a 2 bit delay adjustment index  $DELAY\_ADJ\_INX(m')$  is provided to indicate  
32 which of 4 possible adjusted delay contours has been selected. These processes are described in the following  
33 sections.

1 4.11.5.1 Delay Contour Computation

2 Compute the 8-times oversampled delay contour vector,  $\tau_c(n)$ , defined by:

$$3 \quad \tau_c(n) = \begin{cases} d(m',0) + \frac{n \left[ \dot{d}(m',1) - \dot{d}(m',0) \right]}{L} & ; 0 \leq n < L, \\ d(m',1) + \frac{(n-L) \left[ \dot{d}(m',2) - \dot{d}(m',1) \right]}{L} & ; L \leq n < (L+10) \end{cases} \quad (4.11.5-1)$$

4 where  $m'$  is the current subframe,  $L$  is the current subframe size,  $\dot{d}(m',j)$  is a set of interpolated delays  
5 calculated in 4.11.4.3.

6 4.11.5.2 Mapping of the Adaptive Codebook to the Delay Contour

7 The new adaptive codebook contribution,  $E(n)$ , is calculated by:

$$8 \quad E(n) = \sum_{i=0}^{2f_l} E(i+n-T_E(n)-f_l) I_E \left( i + (2f_l+1)T_{IE}(n) \right) \quad ; 0 \leq n < (L+10), \quad (4.11.5-2)$$

9 where  $T_E(n)$  and  $T_{IE}(n)$  are calculated for every  $n$  by:

$$10 \quad T_E(n) = \begin{cases} \text{round} \{ \tau_c(n) \} & ; \tau_c(n) > 0, \\ -\text{round} \{ -\tau_c(n) \} & ; \tau_c(n) \leq 0, \end{cases}$$

$$11 \quad T_{IE}(n) = \text{trunc} \{ (T_E(n) - \tau_c(n) + 0.5)R + 0.5 \},$$

$$12 \quad \text{if } (T_{IE}(n) == R) \{$$

$$13 \quad \quad T_{IE}(n) = 0$$

$$14 \quad \quad T_E(n) = T_E(n) - 1$$

$$15 \quad \quad \}$$

16 and  $L$  is the current subframe size,  $f_l = 8$ ,  $R = 8$ , and  $\{I_E(n)\}$  is a set of interpolation coefficients found in Table  
17 9-12 through Table 9-14. Then convolve the impulse response,  $h_{wq}(n)$ , with the adaptive codebook excitation,  
18  $E(n)$ , generating the filtered adaptive codebook excitation,  $\lambda(n)$  :

$$19 \quad \lambda(n) = \sum_{j=0}^n h_{wq}(j) E(n-j) \quad ; 0 \leq n < L. \quad (4.11.5-3)$$

20 4.11.5.3 Closed Loop Delay Contour Adjustment

21 The Closed Loop Delay Contour Adjustment process utilizes an adaptive step size that is based on the  
22 variability of the open loop delay parameter  $\tau(m)$ . For the variability estimate, the sample standard deviation of  
23 the current and previous frame's delays are used, which is given as:

$$24 \quad \sigma_\tau = \begin{cases} \frac{1}{\sqrt{2}} |\tau(m) - \tau(m-1)| & ; \text{Rate}(m-1) = \text{Rate } 1 \\ 0 & ; \text{otherwise} \end{cases} \quad (4.11.5-4)$$

1 The variability estimate  $\sigma_\tau$  and the open-loop pitch delay  $\tau(m)$  are then used to calculate the adaptive step size  
2  $\delta(m)$  as:

$$3 \quad \delta(m) = \alpha(\sigma_\tau) \left( \frac{\tau(m) + \tau(m-1)}{2} \right) \quad (4.11.5-5)$$

4 where  $\alpha(\sigma_\tau)$  is a function of the variability estimate of pitch delay given as:

$$5 \quad \alpha(\sigma_\tau) = \min\{0.0020\sigma_\tau + 0.0025, 0.2\}. \quad (4.11.5-6)$$

6 The adaptive step-size  $\delta(m)$  is then used to generate the delay adjust values  $\Delta_{adj}(i)$  calculated as a function of  
7 the delay adjust index  $i$  as:

$$8 \quad \Delta_{adj}(i) = f(i)\delta(m); \quad f(i) = \{+1, -1, +2, -2\}, \quad 0 \leq i \leq 3. \quad (4.11.5-7)$$

9 The delay adjust values are then used to generate a set of candidate delay contours for the subsequent closed  
10 loop search. The four candidates are generated by moving the endpoints of the delay contour up or down  
11 according to the following expression:

$$12 \quad d'(m', j, i) = \min\{\max\{d(m', j) + \Delta_{adj}(i), 20\}, 120\}; \quad 0 \leq i \leq 3 \quad (4.11.5-8)$$

13 and then use these endpoints in the calculation of the delay contour and adaptive codebook contributions, as in  
14 Equations 4.11.5-1 and 4.11.5-2 respectively, to produce the delay adjusted adaptive codebook contributions  
15  $\mathbf{E}(i, n)$ ,  $0 \leq i \leq 3$ . These signals are then convolved with the impulse response  $h_{wq}(n)$  to produce the candidate  
16 filtered ACB excitation vectors  $\lambda(i, n)$ ,  $0 \leq i \leq 3$ .

17 In order to evaluate the candidate vectors from the two ACBs, the delay contour adjusted ACB must perform  
18 significantly better than the default ACB in order to justify dynamically reallocating bits from the FCB to the  
19 ACB. Therefore, a modified mean squared error criteria is used, along with a prediction gain metric, in the  
20 closed loop adjusted delay contour selection process. The baseline performance metrics for the default ACB  
21 are given as:

$$22 \quad MSE = \sum_{n=0}^{L-1} (\hat{s}_w(n) - g_{p\_unq} \lambda(n))^2, \quad (4.11.5-9)$$

23 where  $g_{p\_unq}$  is the unquantized constrained optimum ACB gain given by:

$$24 \quad g_{p\_unq} = \min \left\{ \max \left\{ \frac{\sum_{n=0}^{L-1} \hat{s}_w(n) \lambda(n)}{1 + \sum_{n=0}^{L-1} \lambda^2(n)}, 0.0 \right\}, 1.2 \right\}. \quad (4.11.5-10)$$

25 By clamping the gain to  $0 \leq g_{p\_unq} \leq 1.2$ , the  $MSE$  metric becomes more reliable in that only error metrics  
26 with quantifiable ACB gains are considered. Also, the prediction gain metric, defined by:

$$PGM = \frac{\sum_{n=0}^{L-1} s_w^2(n)}{MSE}, \quad (4.11.5-11)$$

further increases the reliability of the ACB candidate selection by allowing another dimension of the ACB performance to be evaluated. Given this background information, the process for selecting the ACB candidate vector is given in the following pseudo code:

```

5       $C_p = 0$                                 /* Indicate use of default ACB */
6       $MSE_{best} = MSE/1.1$                     /* Set best MSE to default divided by a bias */
7      for  $i = 0$  to 3 {                          /* Evaluate Delay Contour Adjustment ACB
8          if  $MSE_{\lambda(i,n)} < MSE_{best}$  and  $PGM_{\lambda(i,n)} > 1.2$  { /* MSE and PGM for ACB candidate  $\lambda(i,n)$  */
9               $C_p = 1$                             /* Indicate use of Delay Contour Adjustment ACB */
10              $DELAY\_ADJ\_INX(m') = i$             /* Update delay adjust index */
11              $MSE_{best} = MSE_{\lambda(i,n)}$         /* Update best MSE */
12              $\hat{d}(m',j) \leftarrow d'(m',j,i)$     /* Update delay contour endpoints */
13              $\mathbf{E}(n) \leftarrow \mathbf{E}(i,n)$       /* Update unfiltered ACB excitation */
14              $\lambda(n) \leftarrow \lambda(i,n)$     /* Update filtered ACB excitation */
15              $g_{p\_unq} = g_{p\_unq}(i)$           /* Update the unquantized ACB gain */
16         }                                        /* end if */
17     }                                           /* end for */

```

#### 4.11.6 Modification of the Residual

**Inputs:** The inputs to the residual modification are:

- The vector of interpolated delays,  $\hat{d}(m',j)$ , calculated in 4.11.4.3
- The short-term prediction residual,  $\varepsilon(n)$
- The pitch prediction gain,  $\beta$
- The current subframe number,  $m'$
- The current subframe size,  $L$

**Outputs:** The outputs from the residual modification are:

- The modified residual signal,  $\hat{\varepsilon}(n)$

**State Variables Affected:**

- The modified target residual buffer,  $\hat{\varepsilon}_t(n)$ , where  $-128 \leq n \leq 64$
- The pointer to the end of the last residual frame modified,  $n_m$
- The accumulated shift,  $\tau_{acc}$

**Initialization:** The variables used in the residual modification are initialized as follows:

- The modified target residual buffer,  $\hat{\varepsilon}_t(n) = 0$ ;  $-128 \leq n \leq 64$

- 1 • The pointer to the end of the last residual frame modified,  $n_m = 0$
- 2 • The accumulated shift,  $\tau_{acc} = 0$

3 **Processing:** The modification of the residual signal to generate a target residual for the fixed codebook search  
 4 shall be computed according to 4.11.6.1 through 4.11.6.5. A shifted target residual,  $\hat{\varepsilon}_t(n)$ , is generated in  
 5 4.11.6.1 using the past modified residual buffer and the delay contour of the current frame. This shifted  
 6 residual is used as a target for shifting the residual of the current subframe. All the pitch pulses in the original  
 7 residual,  $\varepsilon(n)$ , must be shifted individually to match the delay contour of the modified target residual,  $\hat{\varepsilon}_t(n)$ .  
 8 The modification is performed by finding a shift frame containing each pulse in the original residual by the  
 9 process described in 4.11.6.2. Once the shift frame is found, the accumulated shift,  $\tau_{acc}$ , must be adjusted as  
 10 described in 4.11.6.3 to determine the proper shift needed to match the pulse to the delay contour. The shift  
 11 frame containing the pulse is then shifted by  $\tau_{acc}$  as described in 4.11.6.4. The procedures described in 4.11.6.2  
 12 through 4.11.6.5 must be carried out for all pulses found in the residual of the current subframe.

#### 13 4.11.6.1 Mapping of the Past Modified Residual to the Delay Contour

14 Calculate the target for the residual modification process by warping the past modified residual buffer,  $\hat{\varepsilon}_t(n)$ ,  
 15 by the delay contour,  $\tau_c(n)$ , calculated in 4.11.5.1.

16 The new target residual buffer,  $\hat{\varepsilon}_t(n)$ , is calculated by:

$$17 \quad \hat{\varepsilon}_t(n) = \sum_{i=0}^{2f_l} \hat{\varepsilon}_t(i+n-T_\varepsilon(n)-f_l) I_\varepsilon(i+(2f_l+1)T_{I_\varepsilon}(n)) \quad ; 0 \leq n < (L+10), \quad (4.11.6-1)$$

18 where  $T_\varepsilon(n)$  and  $T_{I_\varepsilon}(n)$  are calculated for every  $n$  by:

$$19 \quad T_\varepsilon(n) = \begin{cases} \text{round}\{\tau_c(n)\} & ; \tau_c(n) > 0, \\ -\text{round}\{-\tau_c(n)\} & ; \tau_c(n) \leq 0, \end{cases}$$

$$20 \quad T_{I_\varepsilon}(n) = \text{trunc}\{(T_\varepsilon(n) - \tau_c(n) + 0.5)R + 0.5\},$$

$$21 \quad \text{if } ((T_{I_\varepsilon}n) == R)$$

$$22 \quad \left\{ \begin{array}{l} 23 \quad T_{I_\varepsilon}(n) = 0 \\ 24 \quad T_\varepsilon(n) = T_\varepsilon(n) - 1 \end{array} \right.$$

$$25 \quad \left. \right\}$$

26 and  $L$  is the current subframe size,  $f_l = 3$ ,  $R = 8$ ,  $\{I_\varepsilon(n)\}$  is a set of interpolation coefficients found in Table 9-10  
 27 and Table 9-11, and  $\tau_c(n)$  is computed in Equation 4.11.5-1.

#### 28 4.11.6.2 Calculation of the Residual Shift Frame Parameters

29 First define the current subframe residual as:

$$30 \quad \varepsilon_s(n) = \varepsilon(n+80+53m') \quad ; 0 \leq n < 240-53m', \quad (4.11.6-2)$$

31 and proceed with the following sections.

1 4.11.6.2.1 Search for Pulses in the Subframe Residual

2 Calculate the location,  $n_{emax}$ , that contains the pulse having maximum energy in the subframe residual. The  
 3 search window is centered at 1/2 the pitch lag,  $\dot{d}(m',1)$ , after the last modified residual sample, and is 1.5 times  
 4 the pitch lag in length. This location,  $n_{emax}$ , is defined as the location,  $n$ , that maximizes:

$$5 \quad E_{\varepsilon}(n) = \sum_{i=-2}^2 \varepsilon_s^2(T+n+i) \quad ; 0 \leq n < 1, \quad (4.11.6-3)$$

6 where the index of the start of the energy search,  $T$ , is defined by:

$$7 \quad T = \max \left\{ \left( n_m + \text{trunc} \{ -\tau_{acc} + 0.5 \} - \text{trunc} \left\{ \frac{1}{4} \dot{d}(m',1) \right\} \right), (-78 - 53m') \right\}, \quad (4.11.6-4)$$

8 where  $n_m$  is an index to the last residual sample modified, and  $\tau_{acc}$  is the accumulated shift; the size of the  
 9 window to be searched,  $l$ , is defined by:

$$10 \quad l = \min \left\{ \text{trunc} \left\{ 1.5 \dot{d}(m',1) \right\}, 238 - 53m' - T \right\}. \quad (4.11.6-5)$$

11 Adjust  $n_{emax}$  by  $\tau_{acc}$ :

$$12 \quad n_{emax} = n_{emax} + T - \text{trunc} \{ -\tau_{acc} + 0.5 \}. \quad (4.11.6-6)$$

13 4.11.6.2.2 Location of the First Pulse in the Residual

14 The location of maximum pulse energy,  $n_{emax}$ , is checked to insure it is the first pitch pulse in the residual. If  
 15 ( $n_{emax} < n_m$ ), the pulse located is in a region that already has been modified, so the residual must be searched  
 16 again using a smaller window size. The new search window is centered one pitch lag,  $\dot{d}(m',1)$ , after the pulse  
 17 location found in 4.11.6.2.1, and is one half of a pitch lag in length. The new location,  $n_{emax}$ , is defined as the  
 18 location,  $n$ , that maximizes:

$$19 \quad E_{\varepsilon}(n) = \sum_{i=-2}^2 \varepsilon_s^2(T+n+i) \quad ; 0 \leq n < 1, \quad (4.11.6-7)$$

20 where the index of the start of the energy search,  $T$ , is defined by:

$$21 \quad T = \max \left\{ \left( n_{emax} + \text{trunc} \{ -\tau_{acc} + 0.5 \} + \text{trunc} \left\{ \frac{3}{4} \dot{d}(m',1) + 0.5 \right\} \right), (-78 - 53m') \right\}, \quad (4.11.6-8)$$

22 where  $n_{emax}$  is the index of the pulse located in 4.11.6.2.1,  $\tau_{acc}$  is the accumulated shift; the size of the window  
 23 to be searched,  $l$ , is defined by:

$$24 \quad l = \min \left\{ \text{trunc} \left\{ 1.5 \dot{d}(m',1) \right\}, 238 - 53m' - T \right\}. \quad (4.11.6-9)$$

1 The location of the maximum pulse,  $n_{emax}$ , is then re-defined and adjusted by:

$$2 \quad n_{emax} = n_{emax} + T - \text{trunc}\{-\tau_{acc} + 0.5\}. \quad (4.11.6-10)$$

### 3 4.11.6.2.3 Location of a Pulse Inside of the Lag Window

4 If  $n_{emax} > \left(n_m + d(m',1)\right)$ , where  $n_{emax}$  was determined in 4.11.6.2.1 or 4.11.6.2.2, the pulse found has a larger  
5 lag than expected. A final pulse energy search of the lag window must be made to insure that the pulse found  
6 at  $n_{emax}$  is the desired pulse to be shifted. The new search window is centered one pitch lag,  $d(m',1)$ , before the  
7 pulse location found in 4.11.6.2.1 or 4.11.6.2.2, and is one half of a pitch lag in length. The location,  $n''_{emax}$ , of  
8 the pulse with maximum energy in the current lag window is defined as the location,  $n$ , that maximizes:

$$9 \quad E_{\varepsilon}(n) = \sum_{i=-2}^2 \varepsilon_s^2(T+n+i) \quad ; 0 \leq n < 1, \quad (4.11.6-11)$$

10 where the index of the start of the energy search,  $T$ , is defined by:

$$11 \quad T = \max \left\{ \left( n_{emax} + \text{trunc}\{-\tau_{acc} + 0.5\} - \text{trunc}\left\{\frac{5}{4}d(m',1) + 0.5\right\} \right), (-78 - 53m') \right\}, \quad (4.11.6-12)$$

12 where  $n_{emax}$  is the index of the pulse determined in 4.11.6.2.1 or 4.11.6.2.2,  $\tau_{acc}$  is the accumulated shift; the size  
13 of the window to be searched,  $l$ , is defined by:

$$14 \quad l = \min \left\{ \text{trunc}\left\{0.5d(m',1)\right\}, 238 - 53m' - T \right\} \quad (4.11.6-13)$$

15 The location,  $n''_{emax}$ , of the maximum pulse in the lag window, is adjusted by  $\tau_{acc}$ :

$$16 \quad n''_{emax} = n''_{emax} + T - \text{trunc}\{-\tau_{acc} + 0.5\}, \quad (4.11.6-14)$$

17 The location of the pulse to be shifted,  $n_{emax}$ , is then re-defined by:

$$18 \quad n_{emax} = \begin{cases} n''_{emax} & ; n''_{emax} \geq n_m, \\ n_{emax} & ; \text{otherwise.} \end{cases} \quad (4.11.6-15)$$

### 19 4.11.6.2.4 Shift Frame Boundary Calculation

20 The boundaries,  $T_{start}$  and  $T_{end}$ , for the frame in the residual to be shifted are calculated by:

$$21 \quad T_{start} = n_m, \quad (4.11.6-16)$$

$$T_{end} = \begin{cases} L & ;L-10 < n_{emax} < L-5, \\ L+10 & ;L < n_{emax} < L+5, \\ L & ;n_{emax} \geq L+5, \\ n_{emax} + 10 & ;\text{otherwise.} \end{cases} \quad (4.11.6-17)$$

#### 4.11.6.2.5 Shift Decision

Calculate a shift decision flag,  $\varepsilon_{shift}$ , by:

$$\varepsilon_{shift} = \begin{cases} FALSE & ;(n_{emax} \geq T_{end}) \text{ or } (n_{emax} < T_{start}), \\ TRUE & ;\text{otherwise.} \end{cases} \quad (4.11.6-18)$$

#### 4.11.6.2.6 Peak to Average Ratio Calculation

If the shift decision flag is true ( $\varepsilon_{shift} == TRUE$ ) as evaluated in 4.11.6.2.5, the ratio of the peak energy to the average energy in the residual frame to be shifted must be calculated to insure that the frame contains a valid pulse. The residual frame to be shifted is defined as  $\varepsilon_s(n)$ , where  $T_{start} \leq n \leq T_{end}$  (see 4.5.6.2 through 4.5.6.4).

Calculate a vector of smoothed residual energies,  $E_{win}(n)$ , by:

$$E_{win}(n) = \sum_{i=0}^4 \varepsilon_s^2(T_{adj} + i + n), \quad 0 \leq n \leq l, \quad (4.11.6-19)$$

where the window size is calculated by:

$$l = T_{end} - T_{start} - 5, \quad (4.11.6-20)$$

and  $T_{adj}$  is calculated as:

$$T_{adj} = T_{start} - \text{trunc}\{\tau_{acc}\}. \quad (4.11.6-21)$$

The peak energy,  $E_{peak}$ , is then calculated as:

$$E_{peak} = \max\{E_{win}(n)\} \quad ;0 \leq n \leq l, \quad (4.11.6-22)$$

and the average energy,  $E_{avg}(n)$ , is calculated as:

$$E_{avg}(n) = \begin{cases} \alpha E_{avg}(n-1) + (1-\alpha)\varepsilon_s^2(T_{adj} + n + 4); & \varepsilon_s^2(T_{adj} + n + 4) < 4E_{avg}(n-1), \\ E_{avg}(n-1) & ;\text{otherwise} \end{cases} \quad 0 < n \leq l, \quad (4.11.6-23)$$

where  $\alpha=0.875$ , and  $E_{avg}(0) = E_{win}(0)$ .

The ratio of the peak to average energy is then calculated by:

$$E_{ratio} = \begin{cases} 0 & ; E_{avg}(l) = 0, \\ \left( \frac{E_{peak}}{E_{avg}(l)} \right) \left( \frac{54}{T_{end} - T_{start}} \right) & ; \text{otherwise,} \end{cases} \quad (4.11.6-24)$$

The shift decision flag,  $\varepsilon_{shift}$ , is then re-defined depending on the peak-to-average ratio by:

$$\varepsilon_{shift} = \begin{cases} FALSE & ; (E_{ratio} < 16.0), \\ TRUE & ; \text{otherwise.} \end{cases} \quad (4.11.6-25)$$

#### 4.11.6.3 Matching the Residual to the Delay Contour

If the shift decision flag is true ( $\varepsilon_{shift} == TRUE$ ) for the current shift frame, update the accumulated shift,  $\tau_{acc}$ . The accumulated shift is adjusted by the shift required to match the residual shift frame determined in 4.5.6.2 to the modified residual target,  $\hat{\varepsilon}_t(n)$ . This operation is detailed in 4.5.6.3.1 through 4.5.6.3.4.

##### 4.11.6.3.1 Computation of the Shift Range

The size of the residual frame to be shifted,  $l$ , is calculated by:

$$l = T_{end} - T_{start}, \quad (4.11.6-26)$$

The residual frame is shifted between  $T_{srl}$  and  $T_{srr}$ , calculated by:

$$T_{srl} = \begin{cases} S_r + 1 & ; \tau_{acc} < 0, \\ S_r & ; \text{otherwise,} \end{cases} \quad (4.11.6-27)$$

$$T_{srr} = \begin{cases} S_r + 1 & ; \tau_{acc} > 0, \\ S_r & ; \text{otherwise,} \end{cases} \quad (4.11.6-28)$$

where  $S_r = 3$ .

For non-periodic signals,  $T_{srl}$  and  $T_{srr}$  are limited as defined by:

$$\begin{aligned} & \text{if } [ (\beta < 0.2) \text{ and } (|\tau_{acc}| > 15) ] \text{ or } [ (\beta < 0.3) \text{ and } (|\tau_{acc}| > 30) ] \\ & \quad \text{if } ( \tau_{acc} < 0 ) \\ & \quad \quad T_{srr} = 1 \\ & \quad \text{else} \\ & \quad \quad T_{srl} = 1 \end{aligned}$$

For both periodic and non-periodic signals, limit the shift bounds,  $T_{srl}$  and  $T_{srr}$ , as defined by:

$$T_{srl} = \min \{ 72 - \text{trunc} \{ \tau_{acc} \}, T_{srl} \}, \quad (4.11.6-29)$$

$$T_{srr} = \min \{ 72 + \text{trunc} \{ \tau_{acc} \}, T_{srr} \}. \quad (4.11.6-30)$$

3GPP2 C.S0014-C ver 1.0

4.11.6.3.2 Generation of a Temporary Modified Residual Signal for Matching

Generate a temporary modified residual,  $\hat{\varepsilon}_{tmp}(n)$ , by shifting the current residual shift frame,  $\varepsilon_s(n)$ , by  $\tau_{acc} + T_{srl}$ :

$$\hat{\varepsilon}_{tmp}(n) = \sum_{i=0}^{2f_l} \hat{\varepsilon}_s(i + T_{start} - T - f_l + n) I_\varepsilon(i + (2f_l + 1)T_l) \quad ; 0 \leq n \leq (T_{srl} + T_{srr}), \quad (4.11.6-31)$$

where  $T$  and  $T_l$  are defined by:

$$T_E(n) = \begin{cases} \text{round}\{\tau_{acc} + T_{srl}\} & ; \tau_{acc} + T_{srl} > 0, \\ -\text{round}\{-(\tau_{acc} + T_{srl})\} & ; \tau_{acc} + T_{srl} \leq 0, \end{cases}$$

$$T_l = \text{trunc}\left\{\left(T - (\tau_{acc} + T_{srl}) + 0.5\right)R + 0.5\right\},$$

$$\text{if } (T_l = R) \{ \\ \quad T_l = 0 \\ \quad T = T - 1 \\ \}$$

and  $l$  is the shift frame size,  $f_l = 3$ ,  $R = 8$ , and  $\{I_\varepsilon(k)\}$  is a set of interpolation coefficients found in Table 9-10 and Table 9-11.

4.11.6.3.3 Matching the Temporary Modified Residual to the Target Residual

Generate an integer energy correlation vector,  $E_f(n)$ :

$$E_f = \sum_{i=0}^{l-1} \hat{\varepsilon}_{tmp}(n+i) \hat{\varepsilon}_t(T_{start} + i) \quad ; 0 \leq n \leq T_{srl} + T_{srr}, \quad (4.11.6-32)$$

where  $\{\hat{\varepsilon}_t\}$  was obtained in 4.5.6.1.

Interpolate  $E_f(n)$  to obtain the fractional energy correlation vector,  $E_f(n)$ :

$$E_f(8(k-1) + j) = \sum_{i=-1}^1 I_f(i, j) E_f(i + K) \quad ; 0 \leq j \leq 7, 0 < T_{srl} + T_{srr}, \quad (4.11.6-33)$$

where  $\{I_f(i, j)\}$  is a set of interpolation coefficients found in Table 9-17.

The optimal shift,  $\tau_{opt}$ , that will match the temporary modified residual to the target residual is then defined as the index,  $n$ , that maximizes  $E_f(n)$ .

4.11.6.3.4 Adjustment of the Accumulated Shift

The accumulated shift is then adjusted by:

$$\tau_{acc} = \begin{cases} \tau_{acc} - \left[ \frac{\tau_{acc} - RT_{srl} + R/2}{R} \right] & ; \alpha > 0.7, \\ \tau_{acc} & ; \text{otherwise,} \end{cases} \quad (4.11.6-34)$$

where  $R = 8$ , and the gain,  $\alpha$ , of the new shift,  $\tau_{opt}$ , is calculated by:

$$\alpha = \begin{cases} 0 & ; E_\varepsilon E_T = 0, \\ \frac{E_f(\tau_{opt})}{\sqrt{E_\varepsilon E_T}} & ; \text{otherwise.} \end{cases} \quad (4.11.6-35)$$

where the energy of the temporary modified residual is calculated by:

$$E_\varepsilon = \sum_{i=T_{srl}}^{l+T_{srl}-1} \hat{\varepsilon}_{imp}^2(i+T_{start}), \quad (4.11.6-36)$$

and the energy of the target modified residual is defined by:

$$E_T = \sum_{i=0}^{l-1} \hat{\varepsilon}_i^2(i+T_{start}). \quad (4.11.6-37)$$

#### 4.11.6.4 Modification of the Residual

The current subframe residual,  $\varepsilon_s(n)$ , is shifted by  $\tau_{acc}$ , to create the modified residual,  $\hat{\varepsilon}(n)$ , for the fixed codebook search:

$$\hat{\varepsilon}(n+n_m) = \sum_{i=0}^{2f_l} \varepsilon_s(i+n+n_m-T-f_l) I_E(i+T_l(2f_l+1)) \quad ; 0 \leq n \leq T_{end} - T_{start}, \quad (4.11.6-38)$$

where  $T$  and  $T_l$  are calculated by:

$$T = \begin{cases} \text{round}\{\tau_{acc}\} & ; \tau_{acc} > 0, \\ -\text{round}\{-\tau_{acc}\} & ; \tau_{acc} \leq 0, \end{cases}$$

$$T_l = \text{trunc}\{(T - \tau_{acc} + 0.5)R + 0.5\},$$

$$\text{if } (T_l = R) \{$$

$$T_l = 0$$

$$T = T - 1$$

$$\}$$

and  $f_l = 8$ ,  $R = 8$ , and  $\{I_\square(n)\}$  is a set of interpolation coefficients found in Table 9-12 through Table 9-14.

Next, use the following pseudo-code to update  $n_m$  and determine whether the pulse searching procedure is complete:

```

if ( $T_{end} < L$ ) {
   $n_m = T_{end}$ 
  Go to 4.5.6.2
} else {
   $n_m = T_{end} - L$ 
  Go to 4.5.6.5
}

```

4.11.6.5 Modified Target Residual Update

After having completed the modification of the residual,  $\hat{\varepsilon}(n)$ , for the entire subframe, the modified target residual buffer,  $\hat{\varepsilon}_i(n)$ , is updated as follows:

$$\hat{\varepsilon}_i(n) = \begin{cases} \hat{\varepsilon}_i(n+L) & ; -128 \leq n < -L \\ \hat{\varepsilon}(n+L) & ; -L \leq n < 0 \end{cases}, \quad (4.11.6-39)$$

4.11.7 Computation of the ACELP Fixed Codebook Contribution for SO 3

The fixed codebook is based on an algebraic codebook structure, which has advantages in terms of storage, search complexity, and robustness. The codebook structure is based on an interleaved single-pulse permutation (ISPP) design. The codebook is searched on a subframe basis for the best index and gain to minimize the mean-squared weighted error between the original and synthesis speech.

**Inputs:** The inputs to the algebraic codebook coding routine are:

- The length  $L$  impulse response of the weighted synthesis filter,  $h_{wg}(k)$ , zero extended to length 55
- The length  $L$  residual domain target vector,  $x(k)$ , zero extended to length 55
- The length  $L$  perceptual domain target vector,  $x_w(k)$ , zero extended to length 55
- The average pitch delay for the current subframe,  $\tau$
- The quantized pitch prediction gain,  $g_p$

**Outputs:** The outputs of the algebraic codebook coding routine are:

- The codeword of the algebraic codebook,  $FCBSIDX(m',i)$ ;  $0 \leq i \leq 3$
- The fixed codebook excitation vector,  $\mathbf{c}_k$
- The fixed codebook gain,  $g_c$

**Processing:** The algebraic codebook shall be implemented using the procedures described in 4.11.7.1 through 4.11.7.4.

4.11.7.1 Algebraic Codebook Structure, Rate 1

The Rate 1 fixed codebook is a 35-bit algebraic codebook. In this codebook, every codebook vector of length 55 contains at most 8 non-zero pulses. All pulses can have the amplitudes +1 or -1. The 55 positions in a subframe are divided into 5 tracks, as shown in Table 4.11.7.1-1. The algebraic codebook search always examines all the 55 positions as shown, regardless of subframe size. Based on the possible subframe size of 53, 53, and 54, the extra positions are ignored.

**Table 4.11.7.1-1 Positions of Individual Pulses in the Rate 1 Algebraic Codebook**

Track	Positions
T0	0, 5, 10, 15, 20, 25, 30, 35,40,45,50
T1	1, 6, 11, 16, 21, 26, 31, 36,41,46,51

T2	2, 7, 12, 17, 22, 27, 32, 37,42,47,52
T3	3, 8, 13, 18, 23, 28, 33, 38,43,48,53
T4	4, 9, 14, 19, 24, 29, 34, 39,44,49,54

1

2 Of the 5 tracks, 3 are allocated two pulses each and 2 are allocated one pulse each. This accounts for a total of 8  
3 pulses. The single-pulse tracks can be either T3-T4, T4-T0, T0-T1, or T1-T2. The choice of single-pulse  
4 tracks is encoded with 2 bits. The positions of the pulses in the 2 single-pulse tracks are encoded with 7 bits  
5 ( $11 \times 11 = 121 < 128$ ) and their signs are encoded with 2 bits. For each double-pulse track, both positions and  
6 signs of the two pulses are encoded with 8 bits, which will be explained in more detail in 4.11.7.3. This gives a  
7 total of 35 bits ( $2+7+2+8 \times 3$ ).

8 The codebook vector,  $\mathbf{c}_k$ , is constructed according to:

$$9 \quad c_k(j) = \sum_{i=0}^{N_p-1} s_i \delta(j - p_i) \quad ; 0 \leq j \leq 54, \quad (4.11.7-1)$$

10 where  $\delta(j - p_i)$  is a unit pulse at the  $i$ -th pulse position  $p_i$  of the  $k$ -th codevector,  $s_i$  is the sign of the  $i$ -th pulse,  
11 and  $N_p$  is the number of pulses, and  $k$  is the range of all possible code vectors.

12 A special feature incorporated in the algebraic codebook is that the selected codebook vector is dynamically  
13 shaped by filtering it through an adaptive pre-filter. In this implementation, the prefilter:

$$14 \quad F(z) = \begin{cases} 1 & ; \tau \geq L, \\ \frac{1}{1 - g_p z^{-\tau}} & ; \text{otherwise,} \end{cases} \quad (4.11.7-2)$$

15 shall be used, where  $\tau$  is the average subframe pitch delay and  $g_p$  is the pitch gain. The pitch gain is the  
16 quantized pitch gain in the current subframe bounded by [0.2, 0.9]. For delays less than 55, the codebook  
17 vector,  $\mathbf{c}_k$ , is modified according to:

$$18 \quad c_k(j) = \begin{cases} c_k(j) & ; 0 \leq j < \tau, \\ c_k(j) + g_p c_k(j - \tau) & ; \tau \leq j \leq 54. \end{cases} \quad (4.11.7-3)$$

19 This modification is incorporated in the fixed codebook search by including the prefilter in the impulse  
20 response  $h_{wq}(j)$ . That is, prior to codebook search, the impulse response  $h_{wq}(j)$  shall be modified according  
21 to:

$$22 \quad h_{wq}(j) = \begin{cases} h_{wq}(j) & ; 0 \leq j < \tau, \\ h_{wq}(j) + g_p h_{wq}(j - \tau) & ; \tau \leq j \leq 54. \end{cases} \quad (4.11.7-4)$$

1 4.11.7.2 Algebraic Codebook Search

2 The algebraic codebook is searched by minimizing the mean-squared error between the weighted input speech  
 3 and the weighted synthesis speech. The perceptual domain target signal  $x_w(n)$  is used in the closed-loop  
 4 fixed-codebook search and is given by Equation 4.11.4-19.

5 Let  $\mathbf{c}_k$  be the algebraic codebook vector at index  $k$ . The algebraic codebook is searched by maximizing the  
 6 term:

$$7 \quad T_k = \frac{C_k}{E_k} = \frac{(\mathbf{d}^t \mathbf{c}_k)^2}{\mathbf{c}_k^t \Phi \mathbf{c}_k}, \quad (4.11.7-5)$$

8 where  $\mathbf{d} = \mathbf{H}^t \mathbf{x}_w$  is the cross-correlation between the perceptual domain target signal  $x_w(n)$  and the impulse  
 9 response  $h_{wq}(n)$ ,  $\Phi = \mathbf{H}^t \mathbf{H}$  is the correlation matrix of the impulse response  $h_{wq}(n)$ , and  $\mathbf{H}$  is a lower  
 10 triangular Toeplitz matrix with diagonal  $h_{wq}(0)$  and lower diagonals  $h_{wq}(1), \dots, h_{wq}(54)$ , i.e.:

$$11 \quad \mathbf{H} = \begin{bmatrix} h_{wq}(0) & 0 & 0 & \dots & 0 \\ h_{wq}(1) & h_{wq}(0) & 0 & \dots & 0 \\ h_{wq}(2) & h_{wq}(1) & h_{wq}(0) & \dots & 0 \\ \vdots & \vdots & \vdots & \ddots & \vdots \\ h_{wq}(54) & h_{wq}(53) & h_{wq}(52) & \dots & h_{wq}(0) \end{bmatrix}. \quad (4.11.7-6)$$

12 The cross-correlation vector  $\mathbf{d}$  and the matrix  $\Phi$  are computed prior to the codebook search. The elements of  
 13 the vector  $\mathbf{d}$  are computed by:

$$14 \quad d(n) = \sum_{j=n}^{54} x_w(j) h_{wq}(j-n) \quad ; 0 \leq n \leq 54, \quad (4.11.7-7)$$

15 and the  $(i, j)$ -th element of the symmetric matrix  $\Phi$  is computed by:

$$16 \quad \phi(i, j) = \begin{cases} \sum_{n=\max\{i, j\}}^{L-1} h_{wq}(n-i) h_{wq}(n-j) & ; (0 \leq j < L) \text{ and } (0 \leq i < L) \\ 0 & ; (L \leq j < 55) \text{ and } (L \leq i < 55) \end{cases}. \quad (4.11.7-8)$$

17 The algebraic structure of the codebook allows for very fast search procedures since the innovation vector,  $\mathbf{c}_k$ ,  
 18 contains only a few non-zero pulses. The correlation in the numerator of Equation 4.11.7-5 is given by:

$$19 \quad c_k = \left( \sum_{i=0}^{N_p-1} s_i d(p_i) \right)^2. \quad (4.11.7-9)$$

20 The energy in the denominator of Equation 4.9.7-5 is given by:

$$21 \quad E_k = \sum_{i=0}^{N_p-1} \phi(p_i, p_i) + 2 \sum_{i=0}^{N_p-2} \sum_{j=i+1}^{N_p-1} s_i s_j \phi(p_i, p_j). \quad (4.11.7-10)$$

1 In order to determine the optimal algebraic codebook vector which maximizes the term in Equation 4.11.7-5,  
 2 the correlation and energy terms in Equation 4.11.7-9 and Equation 4.11.7-10 should be computed for all  
 3 possible combinations of pulse positions and signs. This, however, is a prohibitive task. In order to simplify  
 4 the search, two strategies for searching the pulse signs and positions as explained below shall be used.

5 4.11.7.2.1 Pre-setting of Pulse Signs

6 In order to simplify the search procedure, the pulse signs are preset (outside the closed loop search) by  
 7 considering the sign of an appropriate reference signal. In this case, the signal  $e(i)$ , given by:

$$8 \quad e_i = \sqrt{\frac{\sum_{j=0}^{54} d^2(j)}{\sum_{j=0}^{54} x^2(j)}} x(i) + 2d(i); \quad 0 \leq i \leq 54, \quad (4.11.7-11)$$

9 shall be used, where  $x(i)$  is the residual domain target vector which is described in 4.11.4.10.

10 Amplitude pre-setting shall be done by setting the amplitude of a pulse at position  $i$  equal to the sign of  $e(i)$ .  
 11 Hence, once the sign signal  $s_i = \text{sign}\{e(i)\}$  and the signal  $d'(i) = d(i)s_i$  are computed, then the matrix  $\Phi$  shall be  
 12 modified by including the sign information, that is,  $\phi'(i, j) = s_i s_j \phi(i, j)$ . The correlation in Equation 4.11.7-9  
 13 is now given by:

$$14 \quad c_k = \left( \sum_{i=0}^{N_p-1} d'(p_i) \right)^2, \quad (4.11.7-12)$$

15 and the energy in Equation 4.5.7.2-6 is given by:

$$16 \quad E_k = \sum_{i=0}^{N_p-1} \phi'(p_i, p_i) + 2 \sum_{i=0}^{N_p-2} \sum_{j=i+1}^{N_p-1} \phi'(p_i, p_j). \quad (4.11.7-13)$$

17 4.11.7.2.2 Non-Exhaustive Pulse Position Search

18 Having preset the pulse amplitudes, as explained in 4.11.7.2.1, the optimal pulse positions shall be determined  
 19 using an efficient non-exhaustive analysis-by-synthesis search technique. In this technique, the term in  
 20 Equation 4.11.7-5 is tested for a small percentage of position combinations, using an iterative “depth-first” tree  
 21 search strategy. In this approach, the 8 pulses are grouped into 4 pairs of pulses. The pulse positions shall be  
 22 determined sequentially one pair at a time. In the first iteration, the single-pulse tracks are T3 and T4. The  
 23 search process shall be repeated for other 3 iterations, by assigning the single-pulse tracks to T4-T0, T0-T1, and  
 24 T1-T2 respectively. The codeword,  $q$ , used to represent the various chosen tracks are given in Table  
 25 4.11.7.2.2-1.

26  
 27 **Table 4.11.7.2.2-1 Codeword for the Track Orders**

Double-pulse Track Order (p <sub>0</sub> , p <sub>1</sub> ), (p <sub>2</sub> , p <sub>3</sub> ), (p <sub>4</sub> , p <sub>5</sub> )	Single-pulse Track Order (p <sub>6</sub> , p <sub>7</sub> )	Codeword (q)
T0-T1-T2	T3-T4	00

T1-T2-T3	T4-T0	01
T2-T3-T4	T0-T1	10
T3-T4-T0	T1-T2	11

1

2 Once the positions and signs of the excitation pulses are determined, the codebook vector,  $\mathbf{c}_k$ , shall be built as in  
3 Equation 4.11.7-1 and shall be modified according to Equation 4.11.7-3.

#### 4 4.11.7.3 Codeword Computation of the Algebraic Codebook

5 Upon completion of algebraic codebook search, the positions and signs of the pulses are encoded into 35 bits.  
6 The algebraic codebook routine outputs 4 indices: the first 3 indices (8 bits each) represent the positions and  
7 signs of each double-pulse track and the 4th index (11 bits) represents the positions and signs of pulses in the  
8 two single-pulse tracks (9 bits) along with the codeword for the two single-pulse tracks (2 bits). For the  
9 codeword computations, the following variables are defined for each of the single and double pulse tracks:

$$10 \quad \lambda_0 = \lfloor p_i / 5 \rfloor; \quad i \in \{0, 2, 4, 6\}, \quad (4.11.7-14)$$

$$11 \quad \lambda_1 = \lfloor p_j / 5 \rfloor; \quad j \in \{1, 3, 5, 7\}. \quad (4.11.7-15)$$

12 These are the decimated pulse positions and  $s_{\lambda 0}$  and  $s_{\lambda 1}$  are the signs of the respective decimated positions, and  
13  $b_{\lambda 0}$  and  $b_{\lambda 1}$  are defined as:

$$14 \quad b_{\lambda i} = \begin{cases} 0 & ; s_{\lambda i} > 0, \\ 1 & ; s_{\lambda i} < 0 \end{cases} \quad 0 \leq i \leq 1. \quad (4.11.7-16)$$

15 In the case of coding the 3 double-pulse tracks, each 8 bit codeword  $FCBSIDX(m', i)$ , is ( $0 \leq i \leq 2$ ) calculated  
16 according to:

$$17 \quad FCBSIDX(m', i) = \begin{cases} b_{\lambda k} \times 128 + \min\{\lambda_0, \lambda_1\} \times 11 + \max\{\lambda_0, \lambda_1\}; & \text{if } s_{\lambda 0} = s_{\lambda 1}, \\ b_{\lambda k} \times 128 + \max\{\lambda_0, \lambda_1\} \times 11 + \min\{\lambda_0, \lambda_1\}; & \text{if } s_{\lambda 0} = -s_{\lambda 1}, \end{cases} \quad (4.11.7-17)$$

18 where  $b_{\lambda k}$  follows the sign of the pulse located at the larger decimated position, i.e.,  $\max\{\lambda_0, \lambda_1\}$ . The three  
19 double-pulse codewords  $FCBSIDX(m', i)$ ,  $0 \leq i \leq 2$ , are packed according to the order specified in the Table  
20 4.11.7.2.2-1, which depends on the positions of the single-pulse tracks.

21 In the case of coding the two single-pulse tracks, the 11 bit codeword  $FCBSIDX(m', 3)$  is calculated according  
22 to:

$$23 \quad FCBSIDX(m', 3) = q \times 512 + b_{\lambda 0} \times 256 + b_{\lambda 1} \times 128 + \lambda_0 \times 11 + \lambda_1, \quad (4.11.7-18)$$

24 where  $0 \leq q \leq 3$  is the single-pulse track codeword in Table 4.11.7.2.2-1.

## 1 4.11.7.4 Algebraic Codebook Structure, Rate 1/2

2 A 10 bit algebraic codebook is used for Rate 1/2 packets. The innovation vector contains 3 non-zero pulses.  
 3 Each pulse has 8 possible positions, which are coded by 3 bits. The pulse positions and corresponding  
 4 codewords are given in Table 4.11.7.4-1. All pulses have a fixed signs (+1 for  $T_0$  and  $T_2$  and -1 for  $T_1$ ). An  
 5 additional bit, however, is used to change the signs of all three pulses simultaneously, i.e.,  $s = 1$  indicates  
 6 polarity inversion,  $s = 0$  otherwise. Therefore, the total bits per subframe for Rate 1/2 is  $3*3+1=10$ .

7 The codebook is searched using techniques similar to that for Rate 1. However, in the Rate 1/2 case, all the  
 8 pulse position combinations are exhaustively searched by maximizing Equation 4.11.7-5. Upon completion of  
 9 the search, the sign information is processed as follows:

```

10         if ( sign{  $\mathbf{d}'\mathbf{c}_k$  } < 0 ) {
11              $\mathbf{c}_k = -\mathbf{c}_k$ 
12              $s = 1$ 
13         } else {
14              $s = 0$ 
15         }

```

16 By referencing Table 4.11.7.4-1, the 10-bit codeword can then be calculated by:

$$17 \quad FCBSIDX(m', 0) = s \times 512 + q_{T_0} \times 64 + q_{T_1} \times 8 + q_{T_2} \quad , \quad (4.11.7-19)$$

18 **Table 4.11.7.4-1 Positions of Individual Pulses in the Rate 1/2 Algebraic Codebook**

Pulse	Positions							
$T_0$	0	7	14	21	28	35	42	49
$T_1$	2	9	16	23	30	37	44	51
$T_2$	4	11	18	25	32	39	46	53
<b>Codewords</b> $q_{T_i}; 0 \leq i \leq 2$	000	001	010	011	100	101	110	111

19

1 4.11.8 Computation of the Factorial fixed codebook contribution for SO 68 and SO 70

2 The fixed codebook is based on a factorial codebook structure [R13], which has advantages in terms of storage,  
3 search complexity, and robustness. The codebook is searched on a subframe basis for the best index and gain to  
4 minimize the mean-squared weighted error between the original and synthesis speech.

5 **Inputs**

6 The inputs to the factorial codebook coding routine are:

7 The length  $L$  impulse response of the weighted synthesis filter,  $h_{wg}(k)$ , zero extended to length 55

8 The length  $L$  residual domain target vector,  $x(k)$ , zero extended to length 55

9 The length  $L$  perceptual domain target vector,  $x_w(k)$ , zero extended to length 55

10 The average pitch delay for the current subframe,  $\tau$

11 The quantized pitch prediction gain,  $g_p$

12 For SO 70 wideband mode, the codebook configuration parameter,  $C_p$

13 For SO 70 wideband mode, the filtered ACB excitation,  $\lambda(n)$

14 For SO 70 wideband mode, the unquantized ACB gain,  $g_{p\_unq}$

15 **Outputs**

16 The outputs of the factorial codebook coding routine are:

17 The codeword of the factorial codebook,  $FCBSIDX(m', i)$  ;  $0 \leq i \leq 3$

18 The fixed codebook excitation vector,  $\mathbf{c}_k$

19 The fixed codebook gain,  $g_c$

20 **Processing**

21 The factorial codebook shall be implemented using the procedures described in Sections 4.11.8.1 through  
22 4.11.8.6.

1 4.11.8.1 Fixed codebook (FCB) structure, Rate 1

2 For SO 68 and SO 70 narrowband interoperability mode, the Rate 1 fixed codebook is a 35-bit sparse pulse  
3 codebook. In this codebook, every codevector of length  $L$  contains at most 7 nonzero pulse positions. All  
4 pulses can have the amplitudes of 1 with a sign of +1 or -1. The 7 pulses can take any position in the subframe,  
5 however, any pulses that occupy the same position shall maintain the same sign. Further, up to 7 of these pulses  
6 can be stacked onto the same position. Stacking reduces the number of nonzero pulses, but gives greater  
7 flexibility in controlling the shape for the fixed code vector.

8 For SO 70 wideband mode, the Rate 1 FCB code vector contains either 5 or 6 pulses, depending on the  
9 codebook configuration parameter  $C_p$ . That is, if the default ACB is active ( $C_p = 0$ ), then a 6 pulse fixed  
10 codebook is used. When the delay contour adjustment ACB is active ( $C_p = 1$ ), then a 5 pulse fixed codebook is  
11 used. The number of pulses generated by the various factorial codebooks are shown in Table 4.11.8.1-1.

12  
13 **Table 4.11.8.1-1 Number of Pulses generated by Factorial Codebooks**

SO 68, SO 70 Narrowband Interoperability Mode	SO 70 Wideband Mode	
	$C_p = 0$	$C_p = 1$
$N_p = 7$	$N_p = 6$	$N_p = 5$

14  
15 The maximum number of code-vectors is given by

$$16 \quad N = {}^L FPC_{N_p} = \sum_{p=1}^{N_p} {}^L C_p \binom{N_p-1}{p-1} 2^p, \quad (4.11.8-1)$$

17 where  $N_p$  is the number of unit amplitude pulses,  $L$  is the subframe size, and:

$$18 \quad {}^n C_r = \frac{n!}{r!(n-r)!} \quad (4.11.8-2)$$

19 is the number of ways to choose  $r$  of  $n$  items. It can be easily seen that for  $N_p = 7$  and  $L = 54$ , then the number  
20 of bits required to code the  $N$  unique codeword combinations is  $\lceil \log_2(N) \rceil = 35$  bits. The codeword  $k$  spans the  
21 range  $0 \leq k < N$ . The positions of the pulses are searched as described in Section 4.11.4.11, where the FCB  
22 codevector,  $\mathbf{c}_k$ , is constructed according to:

$$23 \quad c_k(j) = \sum_{i=0}^{N_p-1} s_j \delta(j - p_i) \quad ; 0 \leq j < L, \quad (4.11.8-3)$$

24 where  $\delta(j - p_i)$  is a unit pulse at the  $i$ -th pulse position  $p_i$ , and  $s_j$  is the sign of the  $j$ -th pulse position within the  
25 subframe length  $L$ .

26 A special feature incorporated in the factorial codebook is that the selected codebook vector is dynamically  
27 shaped by filtering it through an adaptive pre-filter. In this implementation, the prefilter:

$$F(z) = \begin{cases} 1 & ; \hat{\tau} \geq L, \\ \frac{1}{1 - g_p z^{-\hat{\tau}}} & ; \text{otherwise,} \end{cases} \quad (4.11.8-4)$$

shall be used, where  $\hat{\tau}$  is the average subframe pitch delay and  $g_p$  is the pitch gain. The pitch gain is the quantized pitch gain in the current subframe bounded by [0.2, 0.9]. For delays less than the subframe length  $L$ , the codebook vector,  $\mathbf{c}_k$ , is modified according to:

$$c_k(j) = \begin{cases} c_k(j) & ; 0 \leq j < \hat{\tau} \\ c_k(j) + g_p c_k(j - \hat{\tau}) & ; \hat{\tau} \leq j < L \end{cases} \quad (4.11.8-5)$$

This modification is incorporated in the fixed codebook search by including the prefilter in the impulse response  $h_{wq}(j)$ . That is, prior to codebook search, the impulse response  $h_{wq}(j)$  shall be modified according to:

$$h_{wq}(j) = \begin{cases} h_{wq}(j) & ; 0 \leq j < \hat{\tau} \\ h_{wq}(j) + g_p h_{wq}(j - \hat{\tau}) & ; \hat{\tau} \leq j < L \end{cases} \quad (4.11.8-6)$$

#### 4.11.8.2 Codebook search

The factorial codebook is searched by minimizing the mean-squared error between the weighted input speech and the weighted synthesis speech. The perceptual domain target signal  $x_w(n)$  is used in the closed-loop fixed-codebook search and is given by Equation 4.9.4-15.

Let  $\mathbf{c}_k$  be the factorial codebook vector at index  $k$ . The factorial codebook is searched by maximizing the term:

$$T_k = \frac{C_k}{E_k} = \frac{(\mathbf{d}^t \mathbf{c}_k)^2}{\mathbf{c}_k^t \Phi \mathbf{c}_k}, \quad (4.11.8-7)$$

where  $\mathbf{d} = \mathbf{H}^t \mathbf{x}_w$  is the cross-correlation between the perceptual domain target signal  $x_w(n)$  and the impulse response  $h_{wq}(n)$ ,  $\Phi = \mathbf{H}^t \mathbf{H}$  is the correlation matrix of the impulse response  $h_{wq}(n)$ , and  $\mathbf{H}$  is a lower triangular Toeplitz matrix with diagonal  $h_{wq}(0)$  and lower diagonals  $h_{wq}(1), \dots, h_{wq}(L-1)$ , i.e.:

$$\mathbf{H} = \begin{bmatrix} h_{wq}(0) & 0 & 0 & \dots & 0 \\ h_{wq}(1) & h_{wq}(0) & 0 & \dots & 0 \\ h_{wq}(2) & h_{wq}(1) & h_{wq}(0) & \dots & 0 \\ \vdots & \vdots & \vdots & \ddots & \vdots \\ h_{wq}(L-1) & h_{wq}(L-2) & h_{wq}(L-3) & \dots & h_{wq}(0) \end{bmatrix} \quad (4.11.8-8)$$

The cross-correlation vector  $\mathbf{d}$  and the matrix  $\Phi$  are computed prior to the codebook search. The elements of the vector  $\mathbf{d}$  are computed by:

$$1 \quad d(n) = \sum_{j=n}^{L-1} x_w(j) h_{wq}(j-n) \quad ; 0 \leq n < L, \quad (4.11.8-9)$$

2 and the  $(i, j)$ -th element of the symmetric matrix  $\Phi$  is computed by:

$$3 \quad \phi(i, j) = \sum_{n=\max\{i, j\}}^{L-1} h_{wq}(n-i) h_{wq}(n-j) \quad ; 0 \leq i < L, \quad 0 \leq j < L. \quad (4.11.8-10)$$

4 For SO 70 wideband mode, a joint parameter optimization approach proposed in [R15] shall be used for the  
 5 factorial codebook search. This method jointly optimizes the adaptive codebook and the fixed codebook gains  
 6 together with the fixed codebook excitation. This is accomplished by modifying the correlation matrix  $\Phi$   
 7 based on the filtered adaptive codebook excitation  $\lambda(n)$ , to produce a modified correlation matrix  $\tilde{\Phi}$ , which is  
 8 then used in place of the original correlation matrix during the subsequent FCB search procedures, i.e.,  
 9  $\Phi \leftarrow \tilde{\Phi}$ .

10 The first step in producing the modified correlation matrix requires the generation of the joint search weighting  
 11 fact  $\lambda_{js}$  given by:

$$12 \quad \lambda_{js} = \begin{cases} 0.0 & ; \dot{\tau} < L \\ \frac{0.97(1.3 - g_{p\_unq})}{\sqrt{1.01R_{\lambda\lambda}(0)}} & ; \dot{\tau} \geq L, g_{p\_unq} \geq 1.15 \\ \frac{0.97g_{p\_unq}}{\sqrt{1.01R_{\lambda\lambda}(0)}} & ; \dot{\tau} \geq L, g_{p\_unq} \leq 0.05 \\ \frac{0.97}{\sqrt{1.01R_{\lambda\lambda}(0)}} & ; otherwise \end{cases} \quad (4.11.8-11)$$

13 where  $R_{\lambda\lambda}(0)$  is the energy of the filtered ACB excitation  $\lambda(n)$ . Then, the backward filtered ACB vector  $\mathbf{y}$  as:

$$14 \quad y(n) = \lambda_{js} \sum_{j=n}^{L-1} \lambda(j) h_{wq}(j-n) \quad ; 0 \leq n < L, \quad (4.11.8-12)$$

15 Finally, the elements of the modified correlation matrix are computed as:

$$16 \quad \tilde{\phi}(i, j) = \phi(i, j) - y(i)y(j) \quad ; 0 \leq i < L, \quad 0 \leq j < L. \quad (4.11.8-13)$$

17 which then replaces the original correlation matrix  $\Phi \leftarrow \tilde{\Phi}$ .

18 The sparse structure of the codebook allows for very fast search procedures since the innovation vector,  $\mathbf{c}_k$ ,  
 19 contains only a few nonzero pulses. The correlation in the numerator of Equation 4.11.8-7 is given by:

$$20 \quad C_k = \left( \sum_{i=0}^{N_p-1} s_i d(p_i) \right)^2. \quad (4.11.8-14)$$

21 The energy in the denominator of Equation 4.11.8-7 is given by:

$$E_k = \sum_{i=0}^{N_p-1} \phi(p_i, p_i) + 2 \sum_{i=0}^{N_p-2} \sum_{j=i+1}^{N_p-1} s_i s_j \phi(p_i, p_j) \quad (4.11.8-15)$$

In order to determine the optimal factorial codebook vector which maximizes the term in Equation 4.11.8.2-7, the correlation and energy terms in Equation 4.11.8.2-14 and Equation 4.11.8.2-15 should be computed for all possible combinations of pulse positions and signs. This, however, is a prohibitive task. In order to simplify the search, two strategies for searching the pulse signs and positions as explained below shall be used.

#### 4.11.8.2.1 Pre-setting of pulse signs

In order to simplify the search procedure, the pulse signs are preset (outside the closed loop search) by considering the sign of an appropriate reference signal. For SO 68 and SO 70 narrowband interoperability mode, the signal  $e(i)$ , given by:

$$e(i) = \sqrt{\frac{\sum_{j=0}^{L-1} d^2(j)}{\sum_{j=0}^{L-1} x^2(j)}} x(i) + 2d(i); \quad 0 \leq i < L, \quad (4.11.8-16)$$

shall be used, where  $x(i)$  is the residual domain target vector which is described in Section 4.11.4.10. For SO 70 wideband mode, the signal  $e(i)$  is defined simply as  $e(i) = d(i); 0 \leq i < L$ .

Sign pre-setting shall be done by setting the sign of a pulse at position  $i$  equal to the sign of  $e(i)$ . Hence, once the sign signal  $s_i = \text{sign}\{e(i)\}$  and the signal  $d'(i) = s_i d(i)$  are computed, then the matrix  $\Phi$  shall be modified by including the sign information, that is,  $\phi'(i, j) = s_i s_j \phi(i, j)$ . The correlation in Equation 4.11.8.2-14 is now given by:

$$c_k = \left( \sum_{i=0}^{N_p-1} d'(p_i) \right)^2, \quad (4.11.8-17)$$

and the energy in Equation 4.11.8.2-15 is given by:

$$E_k = \sum_{i=0}^{N_p-1} \phi'(p_i, p_i) + 2 \sum_{i=0}^{N_p-2} \sum_{j=i+1}^{N_p-1} \phi'(p_i, p_j) \quad (4.11.8-18)$$

#### 4.11.8.2.2 Non-exhaustive pulse position search

Having preset the pulse amplitudes, as explained in Section 4.11.8.2.1, the optimal pulse positions shall be determined using an efficient non-exhaustive analysis-by-synthesis search technique. Once the positions and signs of the excitation pulses are determined, the codebook vector,  $\mathbf{c}_k$ , shall be built as in Equation 4.11.8-3 and shall be modified according to Equation 4.11.8-5.

#### 4.11.8.3 Codeword computation of the factorial codebook

Upon completion of factorial codebook search, the positions and signs of the pulses for SO 68 and SO 70 narrowband interoperability mode are encoded into 35 bits based on the chosen codebook excitation vector,  $\mathbf{c}_k$ .

1

**Table 4.11.8.3-1 Definitions for full-rate CELP factorial codebook**

Code	Definition
$L$	Subframe size
$T$	Total number of unit amplitude pulses
$\tilde{T}$	Number of nonzero pulses (or locations) in the best code vector; $1 \leq \tilde{T} \leq T$
$P_i; 0 \leq i \leq \tilde{T} - 1$	Positions in the code vector that contain the $\tilde{T}$ nonzero pulses; $0 \leq P_i \leq L - 1$
$S_i; 0 \leq i \leq \tilde{T} - 1$	Sign information of the $\tilde{T}$ nonzero pulses; $S_i = \begin{cases} 0; & \text{if sign of pulse at } P_i \text{ is zero or positive} \\ 1; & \text{if sign of pulse at } P_i \text{ is negative} \end{cases}$
$A_i; 0 \leq i \leq \tilde{T} - 1$	Number of unit amplitude pulses in each of the $\tilde{T}$ nonzero pulse locations; $\sum_{i=0}^{\tilde{T}-1} A_i = T$
$T_d^k; 1 \leq k \leq T$	Number of pulse locations with at least $k$ stacked unit amplitude pulses. Note: $T_d^1 = \tilde{T}, T_d^{k-1} \geq T_d^k$
$T_m^k;$	Total number of unit amplitude pulse ( $T$ ) - number of pulse locations with at most $k$ stacked unit amplitude pulses.
$P_d^k; 1 \leq k \leq T$	Set of positions in the code vector that contain at least $k$ stacked unit amplitude pulses; $0 \leq P_d^k \leq L - 1$
$I_{off\_s}(\tilde{T}, T, L)$	Total number of ways of putting $T$ pulses into greater than $\tilde{T}$ nonzero locations. That is, $I_{off\_s}(\tilde{T}, T, L) = \sum_{p=\tilde{T}+1}^T {}^{54}C_p {}^{(7-1)}C_{(p-1)} 2^p$ This is the minimum offset in the code-vector space corresponding to a vector that has exactly $\tilde{T}$ nonzero pulses
$I_{off}(T_d^k, T_m^k, T_d^{k-1})$	Total number of ways of putting $T_m^k$ pulses into greater than $T_d^k$ nonzero locations out of a maximum possible $T_d^{k-1}$ locations. That is, $I_{off}(T_d^k, T_m^k, T_d^{k-1}) = \sum_{p=T_d^k+1}^{T_m^k} T_d^{k-1} C_p {}^{(T_m^k-1)}C_{(p-1)}$
$I_{pos}(P_d^k, T_d^k)$	Sum of the number of ways of putting $p$ pulses in $P_d^k(p)$ , for all $p$ such that $\sum_{p=0}^{T_d^k} (P_d^k(p)) C_p$

2

1 The code-word is given by

$$2 \quad C = \sum_{i=0}^{\tilde{T}-1} (S_i 2^{\tilde{T}-i}) + I_{off\_s}(\tilde{T}, T, L) + \left( \sum_{k=1}^T (I_{off}(T_d^k, T_m^k, T_d^{k-1}) + I_{pos}(P_d^k, T_d^k) D(T_m^k, T_d^k)) \right) 2^{\tilde{T}} \quad (4.11.8-19)$$

3 Basically, given the number of locations of nonzero pulses, their signs, and the number of stacked pulses at  
 4 each of the nonzero locations, the code-word in the above formula is built progressively using offsets.

5 For SO 70 wideband mode, the codebook configuration parameter  $C_p$ , closed loop delay adjustment indices  
 6  $DELAY\_ADJ\_INX(m')$ , and factorial codebook excitation vector  $\mathbf{c}_k$  are coded for all 3 subframes using a single  
 7 94 bit codeword. Details of how the bits are dynamically allocated within the codeword are given in Table  
 8 4.11.8.3-2. From this table, it can be seen that the codebook configuration parameter is coded for the 3  
 9 subframes using a variable length Huffman code, and that the Huffman code indicates which subframes contain  
 10 the default ACB/6 pulse FCB and conversely, which subframes contain the delay adjust ACB/5 pulse FCB.

11

12 **Table 4.11.8.3-2 Dynamic Bit Allocation of Excitation Indices**

Codebook Configuration $C_p$ (number of pulses $N_p$ ) per subframe $m'$			Huffman Code	Huffman bits	Delay Adjust bits per subframe $m'$			FCB bits per frame	Total bits per frame
0	1	2			0	1	2		
0 (6)	0 (6)	0 (6)	0	1	0	0	0	93	94
1 (5)	0 (6)	0 (6)	100	3	2	0	0	89	94
0 (6)	1 (5)	0 (6)	101	3	0	2	0	89	94
0 (6)	0 (6)	1 (5)	110	3	0	0	2	89	94
0 (6)	1 (5)	1 (5)	11100	5	0	2	2	85	94
1 (5)	0 (6)	1 (5)	11101	5	2	0	2	85	94
1 (5)	1 (5)	0 (6)	11110	5	2	2	0	85	94
1 (5)	1 (5)	1 (5)	11111	5	2	2	2	81	92

13

14 In order to efficiently code the factorial codebook indices, the codewords for each of the 3 subframes shall be  
 15 combined together to form a single large codeword. The number of bits for the codeword is determined by the  
 16 relation:

$$17 \quad Total\ FCB\ bits\ / \ frame = \left\lceil \log_2 \left( \prod_{i=0}^2 L_i FPC_{N_i} \right) \right\rceil \quad (4.11.8-20)$$

18 where  $L_i FPC_{N_i}$  is the number of combinations for the  $i$ -th subframe, as described in Equation 4.11.8-1, and  
 19 where  $L_i$  and  $N_i$  are the respective subframe lengths and number of pulses for the  $i$ -th subframe. The total  
 20 number of FCB bits can range from 81 to 93 bits. The FCB codeword is constructed such that the factorial  
 21 codeword  $k_{m'}$  for each subframe is split into a most significant portion  $G_{m'}$  and a least significant portion  $H_{m'}$ ,  
 22 such that  $k_{m'} = [G_{m'}\ H_{m'}]$ , and then combined in a manner that does not require extended precision arithmetic  
 23 operations. This is accomplished by using traditional combinatorial coding only on the most significant parts  
 24 of the 3 subframe codewords  $G_{m'}$ , given in general terms as:

$$\Gamma = \sum_{j=0}^2 \left( \prod_{i=0}^j G_{i-1}^{\max} \right) G_j, \quad (4.11.8-21)$$

where  $G_i^{\max}$  is the number of possible combinations of  $G_i$ , and  $G_{-1}^{\max} = 1$ . The composite FCB codeword  $K$  is then formed by multiplexing (i.e., concatenating) the combined portion of the most significant parts  $\Gamma$  with the least significant portions of the individual codewords  $H_m$ , expressed as:

$$K = [\Gamma \ H_0 \ H_1 \ H_2]. \quad (4.11.8-22)$$

#### 4.11.8.4 Converting a code-word to a code-vector

Given a code-word,  $C$ , the code-vector,  $\mathbf{c}_k$ , is reconstructed using the following iterative procedure, where the notation  $D(x,y) = \binom{x-1}{y-1} C_{(y-1)}$ .

```

11     Tlen = L;
12
13     for (indx=0; indx<Tlen; indx++) {
14         retvector[indx]=0;
15         signvector[indx]=1;
16     }
17
18     Nd=0;
19     do {
20         Tcode = Ioff_S(Nd, Np, Tlen);
21         Nd++;
22     } while(Tcode>code);
23     Nd--;
24     Spos = code & ((0x0001<<Nd) - 1);
25
26     Tcode = (code-Ioff_S(Nd, Np, Tlen))>>Nd;
27     pos = Tcode/ D(Np,Nd);
28     for(indx=0; indx<Nd; indx++) {
29         TNd=Nd-indx-1;
30         while(F(TNd, Nd-indx)<=pos) {
31             TNd++;
32         }
33         TNd--;
34         posvect[Nd-indx-1]=TNd;
35         retvector[TNd]++;
36         signvector[TNd]=(Spos & (0x0001<<(indx)))?-1:1;
37         pos=pos-F(TNd, Nd-indx);
38     }
39     Tcode = (code-Ioff_S(Nd, Np, Tlen))>>Nd;

```

### 3GPP2 C.S0014-C ver 1.0

```

1      pos = Tcode/D(Np,Nd) ;
2      code = Tcode - pos*D(Np,Nd) ;
3      Np = Np - Nd;
4      Tlen = Nd;
5      pv_offset=Tlen;
6      while(Np>0) {
7          Nd=0;
8          while(Ioff(Nd, Np, Tlen)>code) {
9              Nd++;
10         }
11
12         Tcode = (code-Ioff(Nd, Np, Tlen));
13         pos = Tcode/D(Np,Nd) ;
14         for(indx=0; indx<Nd; indx++) {
15             TNd=Nd-indx-1;
16             while(F(TNd, Nd-indx) <= pos) {
17                 TNd++;
18             }
19             TNd--;
20             retvector[posvect[TNd+pv_offset-Tlen]]++;
21             posvect[pv_offset-indx-1]=posvect[TNd+pv_offset-Tlen];
22             pos=pos-F(TNd, Nd-indx);
23         }
24         Tcode = (code-Ioff(Nd, Np, Tlen));
25         pos = Tcode/D(Np,Nd) ;
26         code = Tcode - pos*D(Np,Nd) ;
27         Np = Np - Nd;
28         Tlen = Nd;
29     }
30     for(indx=0; indx<tlen; indx++) {
31         ck [indx]=retvector[indx]*signvector[indx];
32     }
33

```

#### 4.11.8.5 Codebook structure, Rate 1/2

A 10 bit sparse codebook is used for Rate 1/2 packets. The innovation vector contains 3 nonzero pulses. The 3-pulse codebook takes different structures, i.e., allows different pulse positions, depending on the nature of the input signal, pitch lag, periodicity, etc. The bit-usage is reduced by allowing only certain combinations of pulse-positions for the 3-pulses, based on the nature of the input signal.

The codebook is searched using techniques similar to that for Rate 1.

Case 1 ( $lag \geq 95$  or ( $lag > 66$ , and adaptive codebook gain,  $g_p > 0.3$ ))

$$\underline{lag \geq 95}$$

$$sign = 1$$

$$ratio = \min(\max(0.9 * (lag - 95), 0.1), 0.8)$$

$$offset = \begin{cases} 1; & lag < 100 \\ 2; & otherwise \end{cases}$$

$lag > 66$ , and adaptive codebook gain,  $g_p > 0.3$

$$sign = -1$$

$$ratio = 0.0$$

$$offset = 0$$

**Table 4.11.8.5-1 Pulse positions for half-rate CELP codebook**

Pulse	Positions
Possible positions for pulse 0, $p_0$	1, 3, 6, 8, 10, 13, 15, 18, 20, 22, 25, 27, 30, 32, 34, 37, 39, 42, 44, 46, 49, 51
Possible positions for pulse 1, $p_1$	$p_0 + offset$
Possible positions for pulse 2, $p_2$	0, 2, 4, 7, 9, 12, 14, 16, 19, 21, 24, 26, 28, 31, 33, 36, 38, 40, 43, 45, 48, 50, 52

Numerator correlation is

$$c_k = d(p_0) + r \cdot d(p_r) + sign \cdot d(p_1) \quad (4.11.8-23)$$

$$E_k = \phi(p_0, p_0) + r \cdot (r \cdot \phi(p_1) + 2 \cdot \phi(p_0, p_1)) + \phi(p_2, p_2) + 2 \cdot sign \cdot (\phi(p_0, p_2) + r \cdot \phi(p_2, p_1)) \quad (4.11.8-24)$$

Once the best set of  $p_0$ ,  $p_1$ , and  $p_2$  are chosen, the best code vector is given by

$$cb(n) = \begin{cases} s(p_0); & n = p_0 \\ r \cdot s(p_1); & n = p_1 \\ s(p_2); & n = p_2 \end{cases} \quad (4.11.8-25)$$

Case 0 ( $lag \leq 66$ , or ( $lag < 95$ , and adaptive codebook gain,  $g_p \leq 0.3$ ))

$$span = \begin{cases} 24; & g_p > 0.3 \& (lag < SFSIZE) \& (lag < 24) \\ lag; & g_p > 0.3 \& (lag < SFSIZE) \& (lag \geq 24) \\ SFSIZE & otherwise \end{cases}$$

(4.11.8-26)



$$1 \quad h_{wq}(j) = \begin{cases} h_{wq}(j); & 0 \leq j \leq \tau \\ h_{wq}(j) + h_{wq}(j - \tau); & \tau \leq j \leq 54 \end{cases}$$

1 4.11.8.5.1 Converting a Rate  $\frac{1}{2}$  code-word to a code-vector

2 The following pseudo-code illustrates how to convert the code-vector to a code-word:

```

3
4     for (i=0; i<55; i++) cod[i] = 0.0;
5
6     if((*gain_code = Exy / Eyy) < 0) {
7         *gain_code = -(*gain_code);
8         s = -1.0;
9         index = 1;
10    } else {
11        s = 1.0;
12        index = 0;
13    }
14
15    if (flag > 0) {
16        for(i=0; i<3; i++) {
17            pos = pos_table[ix][i];
18            cod[pos] += s;
19            s = -s;
20        }
21        index <<= 9;
22        index += ix;
23    } else {
24        pos = codvec[0];
25        cod[pos] += s;
26        cod[pos+offset[1]] += s * r;
27        i0 = (pos - pos/6)/2;
28
29        pos = codvec[1];
30        cod[pos] += s*sign;
31        i1 = (pos - pos/6)/2;
32
33        index = (index <<9) + i0*23 + i1;
34    }
35
36    *indices = index;
37
38    if(flag == 2)
39        for (i = pit_lag; i < l_subfr; i++) cod[i] += cod[i -
40    pit_lag];
41

```

1 If  $\text{lag} < 54$ , and  $\text{gp} > 0.3$ , the impulse response is pitch sharpened as according to:

$$c_k(j) = \begin{cases} c_k(j) & ; 0 \leq j < \tau, \\ c_k(j) + g_p c_k(j - \tau) & ; \tau \leq j \leq 54. \end{cases}$$

#### 5 4.11.8.6 Fixed Codebook Gain Calculation

6 The fixed codebook gain for both Rate 1 and Rate 1/2 shall be found by:

$$7 \quad g_c = \frac{\mathbf{d}' \mathbf{c}_k}{\mathbf{c}_k' \Phi \mathbf{c}_k}, \quad (4.11.8-32)$$

8 where all variables are previously defined.

### 10 4.12 Voiced encoding (full-rate PPP and quarter-rate PPP)

11 Stationary voiced frames are coded using the Prototype Pitch Period (PPP) synthesis model. In the PPP  
12 synthesis model, only one prototype pitch period waveform is extracted from approximately the end of a frame  
13 of the modified residual is quantized and sent to the decoder. The whole frame of the excitation is reconstructed  
14 at the decoder by pitch synchronous interpolation between the quantized prototype pitch period of the current  
15 frame, and the prototype pitch period of the previous frame.

#### 16 4.12.1 Modification of the original residual

17 Generate a modified residual signal,  $r(n)$ , by shifting the current residual signal,  $\varepsilon(n)$ , to match the delay  
18 contour for the current subframe. See Section 4.11.4.4 for details on this operation.

#### 19 4.12.2 Prototype pitch period processing

20 The Discrete Fourier Series (DFS) representation of the prototype pitch period is used in various aspects of the  
21 voiced encoder. The DFS representation for a signal  $x(n)$  of length  $L$  is defined as

$$22 \quad X(k) = \frac{1}{L} \sum_{n=0}^{L-1} x(n) e^{j \frac{2\pi}{L} kn}; \quad 0 \leq k < L \quad (4.12.2-1)$$

23 As  $X$  is a complex vector, it is equivalently maintained in the speech coder as two vectors –  $X.a$ , the real  
24 vector, and  $X.b$ , the imaginary vector. Further, note that  $x$  is a real vector in the time domain. Therefore, the  
25 DFS components  $X.a$ , and  $X.a$  are symmetric about the frequency  $\pi$ . Therefore,  $X.a$ , and  $X.a$  are  
26 defined by

$$X.a(k) = \begin{cases} \frac{2}{L} \sum_{n=0}^{L-1} x(n) \cos\left(\frac{2\pi}{L} kn\right); & 1 \leq k < \left\lfloor \frac{L-1}{2} \right\rfloor \\ 0; & k = 0 \\ \frac{1}{L} \sum_{n=0}^{L-1} x(n) \cos\left(\frac{2\pi}{L} \frac{L}{2} n\right); & k = \frac{L}{2}; \text{if } L \text{ is even} \end{cases} \quad (4.12.2-2)$$

$$X.b(k) = \begin{cases} \frac{2}{L} \sum_{n=0}^{L-1} x(n) \sin\left(\frac{2\pi}{L} kn\right); & 1 \leq k < \left\lfloor \frac{L-1}{2} \right\rfloor \\ 0; & k = 0 \\ 0; & k = \frac{L}{2}; \text{if } L \text{ is even} \end{cases} \quad (4.12.2-3)$$

The inverse DFS of  $X$  is defined as

$$x(n) = X.a(0) + \sum_{k=1}^{\left\lfloor \frac{L}{2} \right\rfloor} X.a(k) \cos\left(\frac{2\pi}{L} nk\right) + X.b(k) \sin\left(\frac{2\pi}{L} nk\right); \quad 0 \leq n < L \quad (4.12.2-4)$$

For simplicity of notation, we will henceforth simply use the unsubscripted notations like lower-case  $x$ , and the upper-case  $X$  to refer to the time domain vectors, and the DFS representation respectively.

#### 4.12.3 Alignment extraction between two DFS, $X1$ , and $X2$

We refer to the alignment between  $X1$ , and  $X2$  as the circular shift to  $X2$  that would maximize the correlation between the two DFS' in the perceptual weighted domain. Let  $X1p$ , and  $X2p$  be the pole-filtered version of  $X1$ , and  $X2$  through the LPC filter as described in Section 4.12.4.

#### 4.12.4 Pole-filtering a DFS

Pole-filtering is represented in a generic case for a DFS  $X$ , LPC coefficients  $A$ , and output  $Xp$  by the following Equation:

$$Xp.a(k) = \frac{X.a(k) \cdot \left(1 + \sum_{v=0}^9 A(v) \cos\left(\frac{2\pi}{L} kv\right)\right) + X.b(k) \cdot \left(\sum_{v=0}^9 A(v) \sin\left(\frac{2\pi}{L} kv\right)\right)}{\left(1 + \sum_{v=0}^9 A(v) \cos\left(\frac{2\pi}{L} kv\right)\right)^2 + \left(\sum_{v=0}^9 A(v) \sin\left(\frac{2\pi}{L} kv\right)\right)^2}; \quad 0 \leq k \leq \left\lfloor \frac{L}{2} \right\rfloor \quad (4.12.4-1)$$

$$Xp.b(k) = \frac{-X.a(k) \cdot \left( \sum_{v=0}^9 A(v) \sin\left(\frac{2\pi}{L} kv\right) \right) + X.b(k) \cdot \left( 1 + \sum_{v=0}^9 A(v) \cos\left(\frac{2\pi}{L} kv\right) \right)}{\left( 1 + \sum_{v=0}^9 A(v) \cos\left(\frac{2\pi}{L} kv\right) \right)^2 + \left( \sum_{v=0}^9 A(v) \sin\left(\frac{2\pi}{L} kv\right) \right)^2}; \quad 0 \leq k \leq \left\lfloor \frac{L}{2} \right\rfloor$$

2 (4.12.4-2)

3 Let  $X1pz$ , and  $X2pz$  be the pole-zero filtered version of  $X1$ , and  $X2$  obtained by zero-filtering  $X1p$ , and  
 4  $X2p$  through  $A_w$ , the weighted LPC filter,  $A_w(k) = A(k)(0.7^k)$ ;  $0 \leq k < 9$

#### 5 4.12.5 Zero-filtering a DFS

$$Xp.a(k) = X.a(k) \cdot \left( 1 + \sum_{v=0}^9 A(v) \cos\left(\frac{2\pi}{L} kv\right) \right) - X.b(k) \cdot \left( \sum_{v=0}^9 A(v) \sin\left(\frac{2\pi}{L} kv\right) \right); \quad 0 \leq k \leq \left\lfloor \frac{L}{2} \right\rfloor$$

7 (4.12.5-1)

$$Xp.b(k) = X.a(k) \cdot \left( \sum_{v=0}^9 A(v) \sin\left(\frac{2\pi}{L} kv\right) \right) + X.b(k) \cdot \left( 1 + \sum_{v=0}^9 A(v) \cos\left(\frac{2\pi}{L} kv\right) \right); \quad 0 \leq k \leq \left\lfloor \frac{L}{2} \right\rfloor$$

9 (4.12.5-2)

10 The alignment between  $X1$ , and  $X2$  is given by

$$alignment = \arg \max_n \left[ \sum_{k=0}^{\left\lfloor \frac{L}{2} \right\rfloor} \left( (X1.a(k)X2.a(k) + X1.b(k)X2.b(k)) \cos\left(\frac{2\pi}{L} nk\right) + (X1.b(k)X2.a(k) - X1.a(k)X2.b(k)) \sin\left(\frac{2\pi}{L} nk\right) \right) (1 - 0.01|n|) \right];$$

$$- \max(4, L/8) \leq n \leq \max(4, L/8)$$

12 (4.12.5-3)

#### 13 4.12.6 Applying a phase shift to a DFS

14 A phase shift  $\phi$  is applied to a DFS,  $X$ , according to the following Equations

$$\begin{aligned} Xs.a(k) &= X.a(k) \cos(k\phi) - X.b(k) \sin(k\phi) \\ Xs.b(k) &= X.a(k) \sin(k\phi) + X.b(k) \cos(k\phi) \end{aligned}; \quad 0 \leq k \leq \left\lfloor \frac{L}{2} \right\rfloor$$

15 (4.12.6-1)

1 4.12.7 Energy of a DFS,  $X$ 

$$2 \quad \text{energy} = \begin{cases} (X.a(0))^2 + 0.5 \sum_{k=1}^{\lfloor \frac{L-1}{2} \rfloor + 1} ((X.a(k))^2 + (X.b(k))^2), & \text{if } L \text{ is even} \\ (X.a(0))^2 + 0.5 \sum_{k=1}^{\lfloor \frac{L-1}{2} \rfloor} ((X.a(k))^2 + (X.b(k))^2), & \text{otherwise} \end{cases}$$

3 (4.12.7-1)

## 4 4.12.8 Converting a DFS from Cartesian to polar representation

5 Let  $X_c$ , and  $X_p$  be the Cartesian and polar respectively.

$$6 \quad X_p.a(k) = \begin{cases} \frac{\sqrt{(X_c.a(k))^2 + (X_c.b(k))^2}}{2}; & 1 \leq k \leq \left\lfloor \frac{L-1}{2} \right\rfloor; \\ \sqrt{(X_c.a(k))^2 + (X_c.b(k))^2}; & k = \frac{L}{2}; \text{ if } L \text{ is even} \end{cases}$$

(4.12.8-1)

$$7 \quad X_p.b(k) = \tan^{-1} \left( \frac{X_c.b(k)}{\sqrt{(X_c.a(k))^2 + (X_c.b(k))^2}} \right); \quad \begin{cases} 1 \leq k \leq \left\lfloor \frac{L-1}{2} \right\rfloor; \text{ if } L \text{ is odd} \\ 1 \leq k \leq \frac{L}{2}; \text{ if } L \text{ is even} \end{cases}$$

(4.12.8-2)

## 8 4.12.9 Converting a DFS from polar to Cartesian representation

$$9 \quad X_c.a(k) = \begin{cases} 2X_p.a(k) \cos(X_p.b(k)); & 1 \leq k \leq \left\lfloor \frac{L-1}{2} \right\rfloor; \\ X_p.a(k) \cos(X_p.b(k)); & k = L/2; \text{ if } L \text{ is even} \end{cases}$$

(4.12.9-1)

$$10 \quad X_c.b(k) = \begin{cases} 2X_p.a(k) \sin(X_p.b(k)); & 1 \leq k \leq \left\lfloor \frac{L-1}{2} \right\rfloor; \\ X_p.a(k) \sin(X_p.b(k)); & k = L/2; \text{ if } L \text{ is even} \end{cases}$$

(4.12.9-2)

## 11 4.12.10 Normalizing the band energy of a DFS in polar representation

12 The average energy in a DFS between the frequencies  $f_1$ , and  $f_2$  is

$$en = \frac{1}{k_2 - k_1 + 1} \sum_{k=k_1}^{k_2} (X_p \cdot a(k))^2; \quad f_1 < k_1 \frac{8000}{L} \leq k \frac{8000}{L} \leq k_2 \frac{8000}{L} \leq f_2$$

(4.12.10-1)

This is used to scale the DFS between a wider frequency range,  $g_1 \leq f_1$ , and  $g_2 \geq f_2$ , such that the average energy between  $f_1$ , and  $f_2$  is normalized to a value  $en_o$  as shown below

$$X_{1p} \cdot a(k) = \sqrt{\frac{en_o}{en}} X_p \cdot a(k); \quad g_1 < k \frac{8000}{L} \leq g_2$$

(4.12.10-2)

#### 4.12.11 Converting the DFS amplitudes to equivalent rectangular bandwidth (ERB) amplitudes

The ERB amplitudes of a DFS (in the polar form) are obtained as

$$ERB_X(i) = \frac{\sum_k X_p \cdot a(k)}{N_i}; \quad \text{for all } k \text{ such that } erbfreq[i] \leq k \frac{8000}{L} < erbfreq[i+1]$$

(4.12.11-1)

where  $erbfreq[22] = \{0.0, 92.8061, 185.6121, 278.4182, 371.2243, 464.0304, 556.8364, 649.6425, 746.4, 853.6, 972.5, 1104.0, 1251.8, 1415.8, 1599.2, 1804.6, 2035.2, 2294.9, 2588.4, 2921.2, 3300.1, 3733.7, 4001.0\}$  contains the list of 22 frequency edges of the ERB bands.

$$N_j = \left\lfloor \frac{erbfreq[j+1]}{8000/L} \right\rfloor - \left\lfloor \frac{erbfreq[j]}{8000/L} \right\rfloor$$

(4.12.11-2)

is the number of harmonics in the frequency range between  $erbfreq[i]$ , and  $erbfreq[i+1]$ .

#### 4.12.12 LPC power-spectrum

The power-spectrum of a set of LPC coefficients,  $A$ , at a set of NUMFREQ frequencies represented by  $F[ NUMFREQ ]$  is given by

$$PowSpect[i] = \frac{1}{\left(1 + \sum_{v=0}^9 A(v) \cos\left(\frac{2\pi F[i]}{8000}\right)\right)^2 + \left(\sum_{v=0}^9 -A(v) \sin\left(\frac{2\pi F[i]}{8000}\right)\right)^2}; \quad 0 \leq i < NUMFREQ$$

(4.12.12-1)

1 4.12.13 Current to previous PPP energy ratio

$$2 \quad res\_en\_ratio = \frac{currp\_nq\_en}{prev\_ppp\_en} \quad (4.12.13-1)$$

3 where  $currp\_nq\_en$  is the current extract pitch period's energy, computed from  $CURRP\_NQ$  using the  
4 procedure in Section 4.12.7.

5 4.12.14 Full search alignment between two DFS

6 The alignment, searched in the full-range of 0 to  $[0, L2)$ , of a DFS  $X2$ , with lag  $L2$ , w.r.t another DFS  $X1$  is  
7 given by

$$8 \quad alignment = \arg \max_n \left( \sum_{k=0}^{\lfloor \frac{L2}{2} \rfloor} \left( (X1_2.a(k)X2.a(k) + X1_2.b(k)X2.b(k)) \cos\left(\frac{2\pi}{L}nk\right) \right) \right. \\ \left. + (X1_2.b(k)X2.a(k) - X1_2.a(k)X2.b(k)) \sin\left(\frac{2\pi}{L}nk\right) \right) \\ 0 \leq n < L2 \quad (4.12.14-1)$$

9  
10 where  $X1_2$  is a modified version of  $X1$  such that the lag of  $X1_2$  is equal to that of  $X2$ , if  $L1 < L2$ , achieved  
11 using zero-padding shown in Section 4.12.17.

12 4.12.15 Fine search alignment between two DFS

13 The alignment, searched in the range of  $[0, L2)$  (i.e., around an expected alignment of  $n$ ), of a DFS  $X2$ , with  
14 lag  $L2$ , w.r.t another DFS  $X1$  is given by

$$15 \quad alignment = \arg \max_n \left( \sum_{k=0}^{\lfloor \frac{L}{2} \rfloor} \left( (X1_2.a(k)X2.a(k) + X1_2.b(k)X2.b(k)) \cos\left(\frac{2\pi}{L}nk\right) \right) \right. \\ \left. + (X1_2.b(k)X2.a(k) - X1_2.a(k)X2.b(k)) \sin\left(\frac{2\pi}{L}nk\right) \right) (1 - 0.01|n|); \\ -4 \leq n \leq 4; \quad n \text{ increasing in steps of } 0.25 \quad (4.12.15-1)$$

16  
17 where  $X1_2$  is a modified version of  $X1$  such that the lag of  $X1_2$  is equal to that of  $X2$ , if  $L1 < L2$ , achieved  
18 using zero-padding shown in Section 4.12.17.

19 4.12.16 Weighted alignment search between two DFS,  $X1$  and  $X2$

20 We refer to the alignment between  $X1$ , and  $X2$  as the circular shift to  $X2$  that would maximize the  
21 correlation between the two DFS' in the perceptual weighted domain. The alignment is searched in the range of  
22  $[n - 4, n + 4]$ , i.e., around an expected alignment of  $n$  in the perceptually weighted domain. Let  $X1p$ , and  $X2p$   
23 be the pole-filtered version of  $X1$ , and  $X2$  through the LPC filter as described in Section 4.12.4.

- 1 Let  $X1pz$ , and  $X2pz$  be the pole-zero filtered version of  $X1$ , and  $X2$  obtained by zero-filtering  $X1p$ , and  
 2  $X2p$  through  $A_w$ , the weighted LPC filter,  $A_w(k) = A(k)(0.7^k)$ ,  $0 \leq k < 9$  as described in Section 4.12.5.  
 3 The alignment between  $X1$ , and  $X2$  is given by

$$4 \quad \text{weighted\_alignment} = \arg \max_n \left( \sum_{k=0}^{\lfloor \frac{L}{2} \rfloor} \left( (X1.a(k)X2.a(k) + X1.b(k)X2.b(k)) \cos\left(\frac{2\pi}{L}nk\right) \right. \right. \\ \left. \left. + (X1.b(k)X2.a(k) - X1.a(k)X2.b(k)) \sin\left(\frac{2\pi}{L}nk\right) \right) (1 - 0.01|n|) \right);$$

5  $E - \max(6, 0.15 \cdot L) \leq n \leq E + \max(6, 0.15 \cdot L)$   
 6  $n$  increases in steps of 0.25 if  $L < 60$   
 $n$  increases in steps of 0.5 if  $L \geq 60$

(4.12.16-1)

- 7 4.12.17 Zero padding a DFS to have the same lag as another DFS

$$8 \quad X1_2.a(k) = \begin{cases} X1.a(k); & 0 \leq k < \frac{L1}{2} \\ 0; & \frac{L1}{2} \leq k \leq \frac{L2}{2} \end{cases} \quad (4.12.17-1)$$

$$9 \quad X1_2.b(k) = \begin{cases} X1.b(k); & 0 \leq k < \frac{L1}{2} \\ 0; & \frac{L1}{2} \leq k \leq \frac{L2}{2} \end{cases} \quad (4.12.17-2)$$

- 10 4.12.18 Band-limited correlation between two DFS

- 11 The correlation between two DFS' focused in between frequencies  $f1 < f < f2$  is given by

$$12 \quad \text{corr} = \sum_k \left( \begin{array}{l} (X1_2.a(k)X2.a(k) + X1_2.b(k)X2.b(k)) \\ + (X1_2.b(k)X2.a(k) - X1_2.a(k)X2.b(k)) \end{array} \right); \quad \text{for all } k \text{ such that } f1 \leq k \frac{8000}{L} < f2$$

13 (4.12.18-1)

- 14 4.12.19 Speech domain energy of a DFS

- 15 The speech domain energy in between frequencies  $f1 \leq f < f2$  corresponding to a residual domain DFS,  $X_p$   
 16 , and LPC parameters  $A$  of order  $M$ , is given by

$$sp\_energy = \begin{cases} \sum_k \frac{(X_p \cdot a(k))^2}{\left( \left( 1 + \sum_{v=0}^{M-1} \left( A(v) \cos\left(\frac{2\pi vk}{L}\right) \right) \right)^2 + \left( \sum_{v=0}^{M-1} \left( -A(v) \sin\left(\frac{2\pi vk}{L}\right) \right) \right)^2 \right)}; & k = 0, \text{ or } (k = \lfloor L/2 \rfloor \text{ and } L \text{ is even}) \\ \sum_k \frac{2 \cdot (X_p \cdot a(k))^2}{\left( \left( 1 + \sum_{v=0}^{M-1} \left( A(v) \cos\left(\frac{2\pi vk}{L}\right) \right) \right)^2 + \left( \sum_{v=0}^{M-1} \left( -A(v) \sin\left(\frac{2\pi vk}{L}\right) \right) \right)^2 \right)}; & \text{other } k \end{cases}$$

for all  $k$  such that  $f1 \leq k \frac{8000}{L} < f2$

(4.12.19-1)

#### 4.12.20 Grouping DFS harmonics into ERB slots

The representative (central) frequency of the ERB in terms of the harmonics of a DFS is the arithmetic mean of the harmonic frequencies in the ERB band given by, for  $0 \leq j < 22$ .

$$erbfreq(j) = \begin{cases} \frac{k \frac{8000}{L}}{N_j}; & N_j \neq 0, \text{ for all } k \text{ such that } erbfreq[j] \leq k \frac{8000}{L} < erbfreq[j+1] \\ 0; & N_j = 0 \end{cases}$$

(4.12.20-1)

where as earlier

$$N_j = \left\lfloor \frac{erbfreq[j+1]}{8000/L} \right\rfloor - \left\lfloor \frac{erbfreq[j]}{8000/L} \right\rfloor$$

(4.12.20-2)

is the number of harmonics in the frequency range between  $erbfreq[j]$ , and  $erbfreq[j+1]$ . Clearly,  $N_j$  can be zero for some  $j$  depending on the lag,  $L$ .

#### 4.12.21 Zero inserting into a DFS

Interleaving the DFS coefficients with zeros is equivalent to periodically extending the time domain waveform corresponding to the DFS. This zero insertion is described below.

$$X_o \cdot a(k) = \begin{cases} X_i \cdot a\left(\frac{k}{I}\right); & k \% I = 0 \\ 0; & \text{otherwise} \end{cases}; \quad 0 \leq k \leq \left\lfloor \frac{I \cdot L}{2} \right\rfloor$$

1 where the lag of the input DFS is  $L_i$ , and the lag of the output DFS is  $L_i^*$ .

#### 2 4.12.22 Peak to average ratio of PPP from its DFS

3 The DFS  $X$ , is first converted to the time-domain signal. We compute the positive and negative peak-to-  
4 average of  $x$  as follows:

$$5 \quad \text{max\_positive} = \max\left((x(j))^2\right) \quad \text{for all } j \text{ in } [0, L) \text{ such that } x(j) \geq 0$$

6 (4.12.22-1)

$$7 \quad \text{max\_negative} = \max\left((x(j))^2\right) \quad \text{for all } j \text{ in } [0, L) \text{ such that } x(j) < 0$$

8 (4.12.22-2)

$$9 \quad \text{peaktoaverage\_pos} = \sqrt{\frac{\text{max\_positive} \cdot L}{\sum_{j=0}^{L-1} (x(j))^2}}$$

10 (4.12.22-3)

#### 11 4.12.23 Converting ERB amplitudes to DFS amplitudes

12 The DFS amplitudes are reconstructed from the ERB amplitudes by linear interpolation.

$$13 \quad X.a(k) = \frac{\text{currerbQ}(j) \left( k \frac{8000}{L} - \text{erbhfreq}(m-1) \right) + \text{currerbQ}(j-1) \left( \text{erbhfreq}(m) - k \frac{8000}{L} \right)}{\text{erbhfreq}(m) - \text{erbhfreq}(m-1)}$$

14 (4.12.23-1)

15 Using the procedure mentioned in Section 4.12.10, the lower (0 to 1104.5 Hz) and higher frequency bands  
16 (1104.5 to 4000 Hz) of the polar form of  $PREV\_PPP\_E$  are first independently normalized using the  
17 energies  $\text{last\_en}_l$  (the energy between 92.0 and 1104.5), and  $\text{last\_en}_u$  (the energy between 1004.5 to 3300)  
18 respectively.

#### 20 4.12.24 Prototype pitch period extraction

21 While the goal is to extract a prototype pitch period from the end of the current frame of the formant residual, it  
22 is not always as direct as to extract the last  $L$  values of the current frame. This is because if the high energy  
23 pitch spike regions happen to be very close to the ends of the final pitch period, i.e., either close to the end of  
24 the frame, or beginning of the final  $L$  samples, the last  $L$  values may not contain the main pitch spike  
25 completely. This would lead to artifacts during the synthesis. In such cases, the solution is to extract the  
26 prototype pitch period is from slightly ahead in the frame such that the main pitch spike is obtained not from the  
27 end of the frame but from the last but one pitch period of the frame.

1 Let  $spike$  ( $0 \leq spike < L$ ) be the location of the maximum absolute value in the last  $L$  samples of the current  
 2 frame of modified residual,  $r(n)$ . That is,

$$3 \quad spike = \arg \max_{k=0}^{L-1} (abs(r(160 - L + k))) \quad (4.12.24-1)$$

4 Let  $range$  be the number of samples that is considered too close to the end points of the last pitch period, such  
 5 that,

6 Case 1: Spike too close to beginning of last  $L$  samples i.e.,  $spike < range$ .

$$7 \quad currp\_nq\_extracted(n) = \begin{cases} r(160 - L + n); & 0 \leq n < L + spike - range \\ r(160 - 2L + n); & L + spike - range \leq spike < L \end{cases} \quad (4.12.24-2)$$

9 Case 2: Spike too close to end of last  $L$  samples i.e.,  $spike \geq L - range$ .

$$10 \quad currp\_nq\_extracted(n) = \begin{cases} r(160 - L + n); & 0 \leq n < spike - range \\ r(160 - 2L + n); & 160 - 2L + spike - range \geq 0; \\ r(160 - L + n); & otherwise \end{cases}; \quad spike - range \leq n < L$$

11

12 (4.12.24-3)

13 Case 3: Spike not near boundary.

$$14 \quad currp\_nq\_extracted(n) = r(160 - L + n); \quad 0 \leq n < L \quad (4.12.24-4)$$

15 Since the extracted pitch period doesn't always belong to the last  $L$  samples of the frame, the energy of the  
 16 extracted period is matched with the energy of the last  $L$  samples of the frame as follows:

$$17 \quad currp\_nq\_extracted(n) = \sqrt{\frac{\sum_{nn=0}^{L-1} (r(160 - L + nn))^2}{\sum_{nn=0}^{L-1} (currp\_nq\_extracted(nn))^2}} currp\_nq\_extracted(n); \quad 0 \leq n < L$$

18

19 (4.12.24-5)

20 Let  $CURRP\_NQ\_EXTRACTED$  be the Discrete Fourier Series (DFS) of the above extracted prototype pitch  
 21 period.

22 Further, since the extracted pitch period doesn't always belong to the last  $L$  samples of the frame, the extracted  
 23 period is circularly rotated so that it is aligned with the last  $L$  samples of the frame. This alignment is  
 24 performed through correlation search followed by phase shifting. Let  $tmp(n) = r(160 - L + n); \quad 0 \leq n < L$  be a  
 25 temporary signal containing the last  $L$  samples of the frame, and  $TMP$  be the DFS of  $tmp$ . The alignment,  $\alpha$ ,

1 required between *CURRP\_NQ\_EXTRACTED*, and *TMP* is obtained using the following generic method,  
 2 and this is phase shift,  $\alpha$ , is applied (using the method mentioned below) to *CURRP\_NQ\_EXTRACTED* to  
 3 yield *CURRP\_NQ*.

#### 4 4.12.25 Restoring PPP memories if last frame is non-PPP or full-rate PPP

5 If the previous frame was not a PPP frame, then the previous prototype pitch period's DFS, *PREV\_PPP*, is  
 6 computed from the last *PL* values of the pitch memory (excitation memory).

7 The phase offset, *ph\_offset\_E* used in the PPP synthesis is set to 0.

8 The previous prototype pitch period's energy, *prev\_ppp\_en* is computed from *PREV\_PPP* using the  
 9 procedure in Section 4.12.7.

10 Using the procedure mentioned in Section 4.12.10, the lower (0 to 1104.5 Hz) and higher frequency bands  
 11 (1104.5 to 4000 Hz) of the polar form of *PREV\_PPP* are first independently normalized using the energies  
 12 *last\_en<sub>l</sub>* (the energy between 92.0 and 1104.5), and *last\_en<sub>u</sub>* (the energy between 1004.5 to 3300)  
 13 respectively.

14 Further, the previous frame's lower and higher band energy gains are computed as

$$15 \quad \text{lastLgainE} = \log_{10}(L \cdot \text{last\_en}_l) \quad (4.12.25-1)$$

$$16 \quad \text{lastHgainE} = \log_{10}(L \cdot \text{last\_en}_u) \quad (4.12.25-2)$$

17 The normalized previous PPP's DFS in the polar form is used to obtain the last frame's ERB amplitudes,  
 18 *lasterbE*, as described in Section 4.12.11.

#### 19 4.12.26 Correlation between current and previous PPP

20 To determine the correlation between the current and previous PPP, *PREV\_PPP* is first aligned using a full-  
 21 search w.r.t *CURRP\_NQ* as described in Section 4.12.14, and rotated as mentioned in Section 4.12.6  
 22 (equivalently, *CURRP\_NQ* can be rotated in the opposite direction to yield *CURRP\_NQ\_rotated*). The  
 23 residual correlation, *res\_corr*, is then calculated between 100 and 3700 Hz, as mentioned in Section 4.12.18.

24 In addition, the pole-filtered (as in Section 4.12.4) version of *PREV\_PPP\_E*, and  
 25 *CURRP\_NQ\_rotated* are used to compute the speech domain energy ratio, *sp\_en\_ratio*, using a  
 26 procedure same as the one used to calculate *res\_en\_ratio* as in Section 4.12.13.

#### 27 4.12.27 Open-loop coding scheme change

28 Depending on some features of the current frame that detect the suitability of PPP processing, PPP processing  
 29 is discontinued (we use the notation *PPP\_MODE\_E*='B', where *PPP\_MODE\_E* represents the PPP  
 30 processing mode, and can take on three values 'F', 'Q', 'B' representing full-rate PPP, Quarter-rate PPP  
 31 processing, and Full-rate CELP processing respectively) and CELP processing is applied to code the current  
 32 frame. These rules/features satisfying discontinue of PPP processing are described below.

33 If  $(\Delta L = L - PL) < -7$ , or  $(\Delta L = L - PL) > 8$

1           If the anchor operating point,  $OP = 1$ , or ,  $OP = 2$   
2                 If  $NS\_SNR < 25$  ,  $res\_en\_ratio > 5$  , AND  $res\_corr < 0.65$   
3                 Else if  $NS\_SNR \geq 25$  ,  $res\_en\_ratio > 3$  , AND  $res\_corr < 1.2$   
4         Rapid ramp-down frame:  
5                 If the anchor operating point,  $OP = 1$   
6                         If  $NS\_SNR < 25$  , AND  $res\_en\_ratio < 0.025$   
7                         Else if  $NS\_SNR \geq 25$  , AND  $res\_en\_ratio < 0.075$   
8                 If the anchor operating point,  $OP = 2$   
9                         If  $NS\_SNR < 25$  , AND  $res\_en\_ratio < 0.025$   
10                         Else if  $NS\_SNR \geq 25$  , AND  $res\_en\_ratio < 0.075$   
11                         Else if  $NS\_SNR \geq 25$  , AND  $MIN(res\_en\_ratio, sp\_en\_ratio) < 0.075$  ,  
12                         AND  $res\_corr < 0.5$   
13         Rapid ramp-up frame:  
14                 If the anchor operating points,  $OP = 1$ , or  $OP = 2$   
15                         If  $NS\_SNR < 25$  , AND  $res\_en\_ratio > 14.5$   
16                         Else if  $NS\_SNR \geq 25$  , AND  $res\_en\_ratio > 7$   
17         If the anchor operating point,  $OP = 2$   
18                 If  $NS\_SNR \geq 25$  , AND  $res\_corr \leq 0.0$   
19         If the previous frame was quarter-rate NELP, or silence

#### 20   4.12.28 Quarter-rate PPP quantization

21   The Excitation memory from the previous frame is extended into the current frame as described in the Section  
22   4.11.4.8. We call this signal  $acb(n)$ . A prototype pitch period of length  $L$  is extracted from  $acb(n)$  as  
23   described in Section 4.12.24, and let  $ACB$  be the DFS of the extracted PPP from the extended excitation  
24   memory.

##### 25   4.12.28.1   Delta delay quantization

26   The pitch lag for the PPP in QPPP processing is quantized differentially as

$$27 \quad DELTADELAY = L - PL + 7 .$$

##### 28   4.12.28.2   ERB differential amplitude quantization

29   Let  $CURRP\_NQ_p$  be the polar representation of the DFS of  $CURRP\_NQ$ .

30   The speech domain energy of  $CURRP\_NQ_p$  is computed in two frequency bands  $[0,1104.5)$ , and  
31    $[1104.5,4000)$  is computed as shown in Section 4.12.19. Let these be denoted by  $sp\_en1$ , and  $sp\_en2$   
32   respectively. We obtain two speech domain log ratios corresponding to the two frequency bands as,

$$sp\_en\_log\_ratio1 = \frac{\log_{10}(sp\_en1)}{\log_{10}(sp\_en1) + \log_{10}(sp\_en2)} \quad (4.12.28-1)$$

$$sp\_en\_log\_ratio2 = \frac{\log_{10}(sp\_en2)}{\log_{10}(sp\_en1) + \log_{10}(sp\_en2)} \quad (4.12.28-2)$$

Using the procedure mentioned in Section 4.12.10, the lower (0 to 1104.5 Hz) and higher frequency bands (1104.5 to 4000 Hz)  $CURRP\_NQ_p$  are first independently normalized using the energies  $curr\_en_l$  (the energy between 92.0 and 1104.5), and  $curr\_en_u$  (the energy between 1004.5 to 3300) respectively. Let the normalized DFS be  $CURRP\_NQ_p\_norm$ .

Further, the current frame's lower and higher band energy gains are computed as

$$currLgainE = \log_{10}(L \cdot curr\_en_l) \quad (4.12.28-3)$$

$$currHgainE = \log_{10}(L \cdot curr\_en_h) \quad (4.12.28-4)$$

The change in the lower and higher band energy gains between the current and the previous frames are given by,

$$\Delta LgainE = currLgainE - prevLgainE \quad (4.12.28-5)$$

$$\Delta HgainE = currHgainE - prevHgainE \quad (4.12.28-6)$$

These delta lower and higher band energy gains are vector quantized using the speech domain log ratios as weights in the MSE calculation.

$$error(j) = \left( \begin{array}{l} sp\_en\_log\_ratio1 \cdot (|\Delta LgainE - PowerCB[j][0]|) + \\ sp\_en\_log\_ratio2 \cdot (|\Delta HgainE - PowerCB[j][1]|) \end{array} \right) \quad (4.12.28-7)$$

Where  $PowerCB[64][2]$  is the codebook for the delta-band-energy VQ.

The error is further conditioned as

$$error(j) = 0.8 \cdot error(j) \text{ if } \Delta LgainE > PowerCB[j][0] \text{ and } \Delta HgainE > PowerCB[j][1]$$

$$(4.12.28-8)$$

The best VQ codebook index is given by

$$1 \quad \quad \quad \text{POWER\_IDX} = \underset{j}{\arg \min}(\text{error}(j)); \quad 0 \leq j < 64 \quad (4.12.28-9)$$

2 The normalized current PPP's DFS in the polar form,  $CURRP\_NQ_p\_norm$ , is used to obtain the current  
3 frame's ERB amplitudes,  $currerb$ , as described in Section 4.12.11.

4 The current and previous lags are used as mentioned in Section 4.12.20 to give two sets of ERB slot  
5 representative frequencies  $erbfreq\_c$ , and  $erbfreq\_p$  respectively, and  $N_{j,c}$ , and  $N_{j,p}$  being the number  
6 of harmonics in the different ERB bands.

7 Before using it in the amplitude quantization, the empty slots in the previous frame's ERB,  $lasterbE$  are  
8 populated based on whether  $PL > L$ , or  $L > PL$  as follows

$$lasterbE(j) = \begin{cases} \left\{ \begin{array}{l} \text{lasterbE}(k); \text{ if } N_{j,p} = 0, k \text{ is the largest integer } < j, \text{ AND } N_{j,p} \neq 0 \\ \text{lasterbE}(j); \text{ if } N_{j,p} \neq 0 \end{array} \right\}; PL > L \\ \left\{ \begin{array}{l} \text{lasterbE}(k); \text{ if } N_{j,p} = 0, k \text{ is the smallest integer } > j, \text{ AND } N_{j,p} \neq 0 \\ \text{lasterbE}(j); \text{ if } N_{j,p} \neq 0 \end{array} \right\}; PL < L \end{cases}$$

$$0 \leq j < 22$$

9

10

11

(4.12.28-10)

12 Next, the delta between the current and previous ERB amplitudes is computed as

$$13 \quad \quad \quad \Delta erb(j) = currerb(j) - lasterbE(j); \quad 0 \leq j < 22 \quad (4.12.28-11)$$

14 The weighted LPC power-spectrum,  $PowSpectW$ , is computed using  $A_w$ , the weighted LPC  
15 filter,  $A_w(k) = A(k)(0.78^k)$ ,  $0 \leq k < 9$ , using the method described in Section 4.12.12.

16 The  $\Delta erb$  is Vector Quantized in two splits, the first split corresponding to the ERB indices 1 to 10, and the  
17 second split corresponding to the ERB indices 11 to 19. The best indice for the first split is selected as

$$\text{errordist1}(i) = \begin{cases} (\Delta erb(i))^2; & \text{AmpCB1}[k][i-1] < -lasterbE(i) \\ (currerb(i) - \text{AmpCB1}[k][i-1])^2; & \text{otherwise} \end{cases}$$

$$\text{AmpIDX1} = \left\{ \arg \min_k \left( \sum_{i=1}^{10} w1_i (PowSpectW(i) \cdot \text{errordist1}(i)) \right) \right\}$$

where

$$w1_i = \begin{cases} 0.9; & \text{if } \text{AmpCB1}[k][i-1] < \Delta erb(i) \\ 1.0; & \text{otherwise} \end{cases}$$

$i$  such that  $N_i \neq 0$

$$0 \leq k < 64$$

18

(4.12.28-12)

1

2 The best indices for the second split is selected as

$$error_{dist2}(i) = \begin{cases} (\Delta_{erb}(i))^2; & Amp_{CB2}[k][i-11] < -lasterbE(i) \\ (currerb(i) - Amp_{CB2}[k][i-1])^2; & otherwise \end{cases}$$

$$Amp_{IDX2} = \left\{ \arg \min_k \left( \sum_{i=11}^{19} w_{1_i} (PowSpectW(i) \cdot error_{dist2}(i)) \right) \right\}$$

where

$$w_{1_i} = \begin{cases} 0.9; & \text{if } Amp_{CBI}[k][i-11] < \Delta_{erb}(i) \\ 1.0; & otherwise \end{cases}$$

*i such that  $N_i \neq 0$* 

$$0 \leq k < 64$$

3

(4.12.28-13)

4

5 where  $Amp_{CBI}[10][64]$ , and  $A\_Amp_{CB2}[9][64]$  are the codebook for the VQ for the two splits.

## 6 4.12.28.3 ERB differential amplitude dequantization

7 The current and previous lags are used as mentioned in Section 4.12.20 to give two sets of ERB slot  
 8 representative frequencies  $erbhfreq\_c$ , and  $erbhfreq\_p$  respectively, and  $N_{j,c}$ , and  $N_{j,p}$  being the number  
 9 of harmonics in the different ERB bands. Before using it in the amplitude quantization, the empty slots in the  
 10 previous frame's ERB,  $lasterbE$  are populated based on whether  $PL > L$ , or  $L > PL$  as follows:

$$lasterbE(j) = \begin{cases} \left\{ \begin{array}{l} lasterbE(k); \text{ if } N_{j,p} = 0, k \text{ is the largest integer } < j, \text{ AND } N_{j,p} \neq 0 \\ lasterbE(j); \text{ if } N_{j,p} \neq 0 \end{array} \right\}; PL > L \\ \left\{ \begin{array}{l} lasterbE(k); \text{ if } N_{j,p} = 0, k \text{ is the smallest integer } > j, \text{ AND } N_{j,p} \neq 0 \\ lasterbE(j); \text{ if } N_{j,p} \neq 0 \end{array} \right\}; PL < L \end{cases}$$

$$0 \leq j < 22$$

11

12

(4.12.28-14)

13

14 The quantized ERB amplitudes are dequantized according to the following Equation:

$$currerbQ(i) = \begin{cases} MAX(0, lasterbE(i) + AmpCB1[AmpIDX1][i-1]); & i \text{ such that } N_i \neq 0, \text{ and } 0 \leq i < 10 \\ MAX(0, lasterbE(i) + AmpCB2[AmpIDX1][i-11]); & i \text{ such that } N_i \neq 0, \text{ and } 10 \leq i < 19 \\ 0; & N_i = 0 \end{cases}$$

$$currerbQ(0) = 0.3 \cdot currerbQ(1)$$

$$currerbQ(20) = 0.3 \cdot currerbQ(19)$$

$$currerbQ(21) = 0$$

(4.12.28-15)

#### 4.12.28.4 Evaluating the quality of quantization

The quarter-rate PPP amplitude quantization is evaluated for its performance to detect outliers of large errors, and these would be bumped up to full-rate. The following distance metric is computed after the quantization:

$$amerror = \frac{\sum_{i=1}^{10} |currerb(i) - currerbQ(i)|}{N_i}; \quad i \text{ such that } N_i \neq 0$$

(4.12.28-16)

If  $amerror > 0.47$  AND  $\Delta LgainE > -0.4$ , quarter-rate PPP processing is abandoned and the processing is bumped up to full-rate processing.

#### 4.12.28.5 Obtaining the dequantized current PPP DFS

The procedure in Section 4.12.23 is used to convert the quantized  $currerbQ$  to quantized current frame PPP DFS,  $CURRP\_Q_pA$ .

Using the procedure mentioned in Section 4.12.10, the lower (0 to 1104.5 Hz) and higher frequency bands (1104.5 to 4000 Hz)  $CURRP\_Q_pA$  are first independently normalized using the energies  $currq\_en_l$  (the energy of  $CURRP\_Q_pA$  between 92.0 and 1104.5 calculated as in Section 4.12.7), and  $currq\_en_u$  (the energy of  $CURRP\_Q_pA$  between 1004.5 to 3300 calculated as in Section 4.12.7) respectively. Let the normalized DFS be  $CURRP\_Q_pB$ .

This normalized DFS  $CURRP\_Q_pB$  is converted back to ERB amplitudes as in Section 4.12.11, and backed up into  $lasterbE$ .

The lower and upper quantized band energy gains are given by

$$currLgainE = PowerCB[POWER\_IDX][0] + prevLgainE \quad (4.12.28-17)$$

$$currHgainE = PowerCB[POWER\_IDX][1] + prevHgainE \quad (4.12.28-18)$$

1 These are backed into  $prevLgainE$ , and  $prevHgainE$ .

2 Using the procedure mentioned in Section 4.12.10, the lower (0 to 1104.5 Hz) and higher frequency bands  
 3 (1104.5 to 4000 Hz) of  $CURRP\_Q_pA$  are first independently normalized using the energies  $currq\_en_l$  (the  
 4 energy of  $CURRP\_Q_pA$  between 92.0 and 1104.5 calculated as in Section 4.12.7) to  $(10^{currLgainE})/L$ , and  
 5  $currq\_en_u$  (the energy of  $CURRP\_Q_pA$  between 1004.5 to 3300 calculated as in Section 4.12.7) to  
 6  $(10^{currHgainE})/L$  respectively. This gives the amplitudes of the quantized current PPP DFS  $CURRP\_Q_p$

#### 7 4.12.28.6 Copying the phase spectrum of previous PPP DFS

8 In quarter-rate PPP, the phase of the current DFS is set to be equal to the phase of the previous DFS after it is  
 9 extended into the current frame. That is, the phase of  $CURRP\_Q_p$  (which is in polar form) is obtained as  
 10 follows:

$$11 \quad CURRP\_Q_p.b(k) = ACB_p.b(k); \quad 0 \leq k \leq \lfloor L/2 \rfloor \quad (4.12.28-19)$$

12 where  $ACB_p$  is the polar representation of  $ACB$ .

13 In addition a target DFS,  $TARGET\_Q_p$ , whose amplitude is quantized, but which has the unquantized  
 14 prototype's phases is computed as follows:

$$15 \quad TARGET\_Q_p.a(k) = CURRP\_Q_p.a(k); \quad 0 \leq k \leq \lfloor L/2 \rfloor$$

16 (4.12.28-20)

$$17 \quad TARGET\_Q_p.b(k) = CURRP\_NQ_p.b(k); \quad 0 \leq k \leq \lfloor L/2 \rfloor$$

18 (4.12.28-21)

19 The Cartesian representations of  $CURRP\_Q_p$ , and  $TARGET\_Q_p$  (lets call these  $CURRP\_Q$ , and  
 20  $TARGET\_Q$  respectively) are used in the fine alignment method mentioned in Section 4.12.15 to shift  
 21  $TARGET\_Q$  to be aligned with  $CURRP\_Q$ .

#### 22 4.12.28.7 Closed loop bump-up from QPPP to full-rate CELP coding scheme

23 After the above quarter-rate PPP quantization, the following features are used to determine whether the QPPP  
 24 scheme is sufficient for the current frame. If not, full-rate CELP coding scheme is pursued.

25 Operating point average rate

26 Signal-to-noise ratio of the current frame from noise suppression

27 Positive and negative peak to average of  $CURRP\_Q$  (quantized amplitudes, phase copy from  
 28 previous PPP)

29 Positive and Negative peak to average of  $TARGET\_Q$  (true amplitudes, true current phase)

- 1 Energy of the unquantized current PPP
- 2 Energy of the previous quantized PPP
- 3 Positive and negative peak to average of  $CURRP\_NQ$  (quantized amplitudes, true current phase)
- 4 LPC prediction gain
- 5 SNR between  $TARGET\_Q$ , and  $CURRP\_Q$
- 6  $CURRP\_NQ$  residual energy ratio
- 7  $CURRP\_NQ$  speech energy ratio

8 The basic idea is to make sure that some features of the  $CURRP\_NQ$ , the true PPP, should not deviate too  
 9 much upon amplitude quantization, and/or, the phase quantization, i.e., copying of the phase from the past PPP  
 10 extended into the current frame. The tolerances for the deviation are dependent on the Operating Point Average,  
 11 noise suppression SNR, and LPC prediction gain.

12 4.12.29 FPPP DFS amplitude vector quantization

13 Let  $CURRP\_NQ_p$  be the polar representation of the DFS of  $CURRP\_NQ$ .

14 The speech domain energy of  $CURRP\_NQ_p$  is computed in two frequency bands  $[0,1104.5)$ , and  
 15  $[1104.5,4000)$  is computed as shown in Section 4.12.19. Let these be denoted by  $sp\_en1$ , and  $sp\_en2$   
 16 respectively. We obtain two speech domain log ratios corresponding to the two frequency bands as,

$$17 \quad sp\_en\_log\_ratio1 = \frac{\log_{10}(sp\_en1)}{\log_{10}(sp\_en1) + \log_{10}(sp\_en2)} \quad (4.12.29-1)$$

$$18 \quad sp\_en\_log\_ratio2 = \frac{\log_{10}(sp\_en2)}{\log_{10}(sp\_en1) + \log_{10}(sp\_en2)} \quad (4.12.29-2)$$

19 Using the procedure mentioned in Section 4.12.10, the lower (0 to 1104.5 Hz) and higher frequency bands  
 20 (1104.5 to 4000 Hz)  $CURRP\_NQ_p$  are first independently normalized using the energies  $curr\_en_l$  (the  
 21 energy between 92.0 and 1104.5), and  $curr\_en_u$  (the energy between 1004.5 to 3300) respectively. Let the  
 22 normalized DFS be  $CURRP\_NQ_p\_norm$ .

23 Further, the current frame's lower and higher band energy gains are computed as

$$24 \quad currLgainE = \log_{10}(L \cdot curr\_en_l) \quad (4.12.29-3)$$

$$25 \quad currHgainE = \log_{10}(L \cdot curr\_en_h) \quad (4.12.29-4)$$

26 These lower and higher band energy gains are vector quantized using the speech domain log ratios as weights  
 27 in the MSE calculation.

$$error(j) = \begin{cases} sp\_en\_log\_ratio1 \cdot (|currLgainE - A\_PowerCB[j][0]|) + \\ sp\_en\_log\_ratio2 \cdot (|currHgainE - A\_PowerCB[j][1]|) \end{cases} \quad (4.12.29-5)$$

Where  $A\_PowerCB[256][2]$  is the codebook for the delta-band-energy VQ.

The error is further conditioned as

$$error(j) = 0.8 \cdot error(j) \text{ if } currLgainE > A\_PowerCB[j][0] \text{ and } currHgainE > A\_PowerCB[j][1] \quad (4.12.29-6)$$

The best VQ codebook index is given by

$$POWER\_IDX = \arg \min_j (error(j)); \quad 0 \leq j < 256 \quad (4.12.29-7)$$

The normalized current PPP's DFS in the polar form,  $CURRP\_NQ_p\_norm$ , is used to obtain the current frame's ERB amplitudes,  $currerb$ , as described in Section 4.12.11.

The current lag are used as mentioned in Section 4.12.20 to give a set of ERB slot representative frequencies  $erbfreq\_c$ , and  $N_{j,c}$ , being the number of harmonics in the different ERB bands.

The weighted LPC power-spectrum,  $PowSpectW$ , is computed using  $A_w$ , the weighted LPC filter,  $A_w(k) = A(k)(0.78^k)$ ,  $0 \leq k < 9$ , using the method described in Section 4.12.12.

The  $currerb$  is Vector Quantized in three splits, the first split corresponding to the ERB indices 0 to 4, the second split corresponding to the ERB indices 5 to 9, and the third split corresponding to the ERB indices 10 to 18.

The best indices for the first split is selected as

$$A\_AmpIDX1 = \arg \min_k \left( \sum_{i=0}^4 w1_i (PowSpectW(i) \cdot (currerb(i) - A\_AmpCBI[k][i])^2) \right);$$

where

$$w1_i = \begin{cases} 0.9; & \text{if } A\_AmpCBI[k][i] < currerb(i) \\ 1.0; & \text{otherwise} \end{cases}$$

$i$  such that  $N_i \neq 0$

$$0 \leq k < 64 \quad (4.12.29-8)$$

The best indices for the second split is selected as

$$A\_AmpIDX2 = \arg \min_k \left( \sum_{i=5}^9 w2_i \left( PowSpectW(i) \cdot (currerb(i) - A\_AmpCB2[k][i-6])^2 \right) \right);$$

where

$$w2_i = \begin{cases} 0.9; & \text{if } A\_AmpCB2[k][i] < currerb(i) \\ 1.0; & \text{otherwise} \end{cases}$$

$i$  such that  $N_i \neq 0$

$$0 \leq k < 64$$

(4.12.29-9)

The best indices for the 3rd split is selected as

$$A\_AmpIDX3 = \arg \min_k \left( \sum_{i=10}^{18} w3_i \left( PowSpectW(i) \cdot (currerb(i) - A\_AmpCB3[k][i-10])^2 \right) \right);$$

where

$$w3_i = \begin{cases} 0.9; & \text{if } A\_AmpCB3[k][i] < currerb(i) \\ 1.0; & \text{otherwise} \end{cases}$$

$i$  such that  $N_i \neq 0$

$$0 \leq k < 256$$

(4.12.29-10)

where  $A\_AmpCB1[5][64]$ ,  $A\_AmpCB2[5][64]$  and  $A\_AmpCB3[9][256]$  are the codebook for the VQ for the two splits.

#### 4.12.29.1 ERB amplitude dequantization

The quantized ERB amplitudes are dequantized according to the following Equation

$$currerbQ(i) = \begin{cases} A\_AmpCB1[AmpIDX1][i]; & i \text{ such that } N_i \neq 0, \text{ and } 0 \leq i < 5 \\ A\_AmpCB2[AmpIDX2][i-5]; & i \text{ such that } N_i \neq 0, \text{ and } 5 \leq i < 9 \\ A\_AmpCB3[AmpIDX3][i-10]; & i \text{ such that } N_i \neq 0, \text{ and } 10 \leq i < 19 \\ 0; & N_i = 0 \end{cases}$$

$$currerbQ(0) = 0.3 \cdot currerbQ(1)$$

$$currerbQ(20) = 0.3 \cdot currerbQ(19)$$

$$currerbQ(21) = 0$$

(4.12.29-11)

The procedure in Section 4.12.23 is used to convert the quantized  $currerbQ$  to quantized current frame PPP DFS,  $CURRP\_Q_pA$ .

Using the procedure mentioned in Section 4.12.10, the lower (0 to 1104.5 Hz) and higher frequency bands (1104.5 to 4000 Hz) of  $CURRP\_Q_pA$  are first independently normalized using the energies  $currq\_en_l$  (the energy of  $CURRP\_Q_pA$  between 92.0 and 1104.5 calculated as in Section 4.12.7) to  $\left(10^{currLgainE}\right)/L$ , and

1  $currq\_en_u$  (the energy of  $CURRP\_Q_pA$  between 1004.5 to 3300 calculated as in Section 4.12.7) to  
 2  $\left(10^{currHgainE}\right)/L$  respectively. This gives the amplitudes of the quantized current PPP DFS  $CURRP\_Q_p$ .

### 3 4.12.29.2 Phase quantization

4 The phases of DFS,  $CURRP\_Q_p$ , is set to zero as follows:

$$5 \quad CURRP\_Q_p.b(k) = 0; \quad 0 \leq k \leq \lfloor L/2 \rfloor \quad (4.12.29-12)$$

6 A target DFS,  $TARGET\_Q_p$ , whose amplitude is quantized, but which has the unquantized prototype's phases  
 7 is computed as follows:

$$8 \quad TARGET\_Q_p.a(k) = CURRP\_Q_p.a(k); \quad 0 \leq k \leq \lfloor L/2 \rfloor$$

9 (4.12.29-13)

$$10 \quad TARGET\_Q_p.b(k) = CURRP\_NQ_p.b(k); \quad 0 \leq k \leq \lfloor L/2 \rfloor$$

11 (4.12.29-14)

12  $CURRP\_Q_p$ , and  $TARGET\_Q_p$  are converted to Cartesian representation as shown in Section 4.12.9,  
 13 and then converted to the perceptually weighted domain by pole-filtering using  $A_w$ , the weighted LPC filter,  
 14  $A_w(k) = A(k)(0.8^k)$ ,  $0 \leq k < 9$ . Let's identify the resulting DFS' by  $CURRP\_Q_s$ , and  $TARGET\_Q_s$   
 15 respectively.

#### 16 4.12.29.2.1 Global alignment

17 The alignment between  $CURRP\_Q_s$ , and  $TARGET\_Q_s$ , is searched in the full-range of 0 to  $[0, L)$ , as shown  
 18 below.

$$19 \quad alignment = \arg \max_n \left( \sum_{k=0}^{\lfloor \frac{L-2}{2} \rfloor} \left( \begin{aligned} & \left( CURRP\_Q_s.a(k)TARGET\_Q_s.a(k) \right) \cos\left(\frac{2\pi}{128}nk\right) \\ & + CURRP\_Q_s.b(k)TARGET\_Q_s.b(k) \end{aligned} \right) \right. \\ \left. + \left( \begin{aligned} & CURRP\_Q_s.b(k)TARGET\_Q_s.a(k) \\ & - CURRP\_Q_s.a(k)TARGET\_Q_s.b(k) \end{aligned} \right) \sin\left(\frac{2\pi}{128}nk\right) \right) \right);$$

20  $0 \leq n < 128$

21 (4.12.29-15)

22  $CURRP\_Q_s$  is then shifted by the negative of this alignment as described in Section 4.12.6. This corresponds  
 23 to applying an expected linear phase shift to the PPP represented by  $CURRP\_Q_s$  to maximally align with the  
 target (quantized amplitude but true phase) PPP.  $TARGET\_Q_s$ .

1 4.12.29.2.2 Band alignment

2 Since the linear phase shift is insufficient to capture the true phase of all harmonics, we compute band-focused  
 3 alignments, in addition to the global alignment, in multiple bands (whose band-edges are given below).

4 F\_BAND[18]={0,200,300,400,500,600,850,1000,1200,1400,1600,1850,2100,2375,2650,2950,3250,4000}  
 5 ;

6 The band alignment between CURRP\_Q<sub>S</sub>, and TARGET\_Q<sub>S</sub>, is searched in the range of [-16,16), for a  
 7 band of frequencies [lband, hband) as shown below:

$$band\_alignment(j) = \frac{16}{\eta} + \arg \max_n \left( \sum_k \left( \begin{array}{l} \left( CURRP\_Q_S.a(k)TARGET\_Q_S.a(k) \right) \cos\left(\frac{2\pi}{L}n\eta k\right) \\ + CURRP\_Q_S.b(k)TARGET\_Q_S.b(k) \end{array} \right) \right. \\ \left. + \left( \begin{array}{l} CURRP\_Q_S.b(k)TARGET\_Q_S.a(k) \\ - CURRP\_Q_S.a(k)TARGET\_Q_S.b(k) \end{array} \right) \sin\left(\frac{2\pi}{L}n\eta k\right) \right) \right);$$

$$0 \leq j < 17$$

$$-\frac{16}{\eta} \leq n < \frac{16}{\eta}; n \text{ increasing in steps of } 1$$

$$\text{all } k \in \left[ 0, \left\lfloor \frac{L}{2} \right\rfloor \right] \text{ such that } lband(j) \leq k \frac{8000}{L} < hband(j)$$

where,  $\eta = \begin{cases} 1; & j < 3 \\ 0.5; & 3 \leq j < 17 \end{cases}$

and,  $lband(j) = F\_BAND[j]$

$hband(j) = F\_BAND[j + 1]$

If for a given lband, hband, and L, there is no k such that  $lband \leq k \frac{8000}{L} < hband$ ,

8  $band\_alignment(j) = INVALID\_ID;$

9

10 Such band alignments with INVALID\_ID are not packed.

11 The band phase shift  $\phi$  is applied to a DFS, CURRP\_Q<sub>S</sub>, according to the following equations

$$\begin{aligned}
CURRP\_Q_s.a(k) &= \left[ \begin{array}{l} CURRP\_Q_s.a(k) \cos \left( -k \frac{2\pi}{L} \eta \left( -\frac{16}{\eta} + band\_alignment(j) \right) \right) \\ CURRP\_Q_s.b(k) \sin \left( -k \frac{2\pi}{L} \eta \left( -\frac{16}{\eta} + band\_alignment(j) \right) \right) \end{array} \right] - \\
CURRP\_Q_s.s.b(k) &= \left[ \begin{array}{l} CURRP\_Q_s.a(k) \sin \left( -k \frac{2\pi}{L} \eta \left( -\frac{16}{\eta} + band\_alignment(j) \right) \right) \\ CURRP\_Q_s.b(k) \cos \left( -k \frac{2\pi}{L} \eta \left( -\frac{16}{\eta} + band\_alignment(j) \right) \right) \end{array} \right] + \\
0 \leq k &\leq \left\lfloor \frac{L}{2} \right\rfloor \\
0 \leq j &< 17 \\
-\frac{16}{\eta} \leq n &< \frac{16}{\eta}; n \text{ increasing in steps of } 1 \\
&\text{for every } j, \\
k \in \left[ 0, \left\lfloor \frac{L}{2} \right\rfloor \right] &\text{ such that } lband(j) \leq k \frac{8000}{L} < hband(j)
\end{aligned}$$

$$\text{where, } \eta = \begin{cases} 1; & j < 3 \\ 0.5; & 3 \leq j < 17 \end{cases}$$

$$\text{and, } lband(j) = F\_BAND[j]$$

$$hband(j) = F\_BAND[j+1]$$

1  
2

3  $CURRP\_Q_s$  is then zero filtered using the procedure in Section 4.12.5, and  $A_w$ , the weighted LPC filter,  
4  $A_w(k) = A(k)(0.8^k)$ ,  $0 \leq k < 9$  to obtain the quantized full-rate PPP DFS,  $CURRP\_Q$ .

#### 5 4.12.30 PPP synthesis

6 Now that we have the quantized current PPP DFS,  $CURRP\_Q$ , and the previous DFS,  $PREV\_PPP$ , we  
7 generate the 160 samples of the current frame as below, adjusting the previous and current PPP for synthesis if  
8 pitch double or halving.

9 The running phase-offset of the previous the previous frame's PPP is first updated if the current pitch is more  
10 than the two times the previous frame's pitch lag. That is

$$11 \quad phase\_offset = phase\_offset / I; \quad \text{if } L / PL > 2.$$

12 Further, if  $L > 2PL$ , the previous frame DFS,  $PREV\_PPP$ , is zero-inserted as described in Section 4.12.21,  
13 and a flag signal,  $synthesis\_flag$  is set to 1. This corresponds to interpolating the time-domain signal.

14 If  $PL > L$ , the current frame DFS,  $CURRP\_Q$ , is zero-inserted as described in Section 4.12.21, and the flag  
15 signal,  $synthesis\_flag$  is set to 2.

## 1 4.12.30.1 Calculating the expected alignment shift

2 The expected alignment shift between the previous PPP and the current PPP is computed as

$$E_{rot} = \text{rem} \left( \left( \left[ \text{rem} \left( 160, \left\lfloor \frac{L + PL}{2} \right\rfloor \right) \right] + \text{alignment\_offset} \right), L \right)$$

3

4 where

$$\text{alignment\_offset} = \begin{cases} 2\pi \cdot PL \cdot \text{phase\_offset} \cdot \text{round} \left( \frac{L}{PL} \right); & \text{if } \text{synthesis\_flag} = 1 \\ 2\pi \cdot PL \cdot \text{phase\_offset}; & \text{otherwise} \end{cases}$$

5

6

## 7 4.12.30.2 Computing the actual alignment shift and shifting the current PPP

8 The actual alignment between the previous PPP, and the current PPP is computed around  $E_{rot}$  using the  
9 weighted alignment method described in Section 4.12.16. Let the result of this alignment be  
10  $\text{alignment\_synthesis}$ . The current PPP,  $\text{CURRP\_Q}$ , is then phase shifted by11  $\text{phaseshift\_synthesis} = \frac{2\pi \cdot \text{alignment\_synthesis}}{L}$  as described in Section 4.12.6.

## 12 4.12.30.3 Computation of the cubic phase track for the synthesis of one frame of residual

13 The phase track used to synthesis the whole frame of residual from the previous and current PPP is modeled  
14 using a cubic polynomial as below

$$\text{phase\_out}(n) = \begin{cases} \text{rem}(\text{phase\_offset}, 2\pi) & ; n = 0 \\ ((\text{coef}[0] \cdot n + \text{coef}[1]) \cdot n + \text{coef}[2]) \cdot n + \text{coef}[3] & ; 1 \leq n < 160 - L \\ \text{phase\_out}(n-1) + \frac{2\pi}{L} & ; 1 \leq n < 160 - L \end{cases}$$

16 where the coefficients of the cubic polynomial,  $\text{coef}[4]$ , are computed as below

17 
$$\text{coef}[3] = \text{rem}(\text{phase\_offset}, 2\pi)$$

18 
$$\text{coef}[2] = \frac{2\pi}{PL}$$

19 
$$\text{coef}[0] = \left( N_{rem} \left( 2\pi \left( \frac{1}{L} - \frac{1}{PL} \right) \right) \right) - \left( 2 \cdot \left( \text{phaseshift\_synthesis} - \text{phase\_offset} - N_{rem} \cdot \frac{2\pi}{PL} + 2\pi\zeta \right) \right)$$

20

21 where,  $N_{rem} = (160 - L)$ , represents the initial region of the current frame not containing the current PPP  
22 (which represents the end of the frame), and

23 
$$\zeta = \text{round} \left( \frac{\text{phase\_offset} - \text{phaseshift\_synthesis} + 0.5N_{rem} 2\pi \left( \frac{1}{L} + \frac{1}{PL} \right)}{2\pi} \right)$$

$$coef[1] = \frac{2\pi\left(\frac{1}{L} + \frac{1}{PL}\right) - 3N_{rem}^2 coef[0]}{2N_{rem}}$$

#### 4.12.30.4 Generating the whole frame of residual

Using the current, and previous PPP, and the above described cubic phase track, the whole frame of residual is synthesized as described below.

The number of intermediate Pitch periods to be synthesized is given by

$$N_{synth} = round\left(\frac{N}{\lfloor 0.5(L + PL) \rfloor}\right)$$

The PPP DFS with the shorter lag between the current and the previous PPP is first zero-padded to the larger lag as described in Section 4.12.17. Thus,  $CURRP\_Q$ , and,  $PREV\_PPP$ , are made to be of the same pitch lag.

$r_q(n)$ , the residual of the frame is generated for  $0 \leq n < 160$ , inverse discrete Fourier series inverse transform calculated at  $n$ , of a phase-shifted (given by the phase-track) time varying DFS,  $PPP\_SYNTH(n)$  that is the interpolated version of  $CURRP\_Q$ , and,  $PREV\_PPP\_E$ , and the phase track, computed as below.

$$PPP\_SYNTH(n).a(k) = (1 - w(n))(PREV\_PPP.a(k)) + w(n)(CURRP\_Q.a(k)); \quad 0 \leq k \leq \lfloor L/2 \rfloor$$

$$PPP\_SYNTH(n).b(k) = (1 - w(n))(PREV\_PPP.b(k)) + w(n)(CURRP\_Q.b(k)); \quad 0 \leq k \leq \lfloor L/2 \rfloor$$

where the time varying interpolation weight is given by

$$w(n) = \begin{cases} 1 - e^{-\left((n+1)\log\left(\frac{0.2}{L-160}\right)\right)}; & \text{if } L < 140 \\ \frac{n+1}{160}; & \text{otherwise} \end{cases}$$

#### 4.12.31 Perceptual weighting filter update

Although there is no closed-loop search at Rate 1 and Rate 1/4 PPP coding, it is still necessary to update the memory of the perceptual weighting filter with the new excitation determined in 4.6.7 for each subframe. Update the weighted synthesis filter memory by filtering the excitation vector,  $rq(n)$ , through the weighted synthesis filter,  $Hwq(z)$ , which is given in Equation 4.11.4-5.

### 4.13 Encoding at Rate 1 Generic Audio for SO 70

The Generic Audio frame type of SO 70 is used to code music, tones, and other types of non-speech input signals.

#### Input:

- The pre-processed speech input vector,  $\{s'(n)\}$

**Output:**

- The quantized LSP indices,  $LSPIDX(k)$
- The quantized MDCT coefficient (residual line spectrum) index,  $RLSIDX$
- The quantized global scale factor index,  $GSFIDX$
- The quantized Noise Injection level indices,  $NILIDX$

**Initialization:**

The following state variables shall be set to zero at initialization (frame  $m = 0$ ):

- The formant emphasis and de-emphasis filter memories
- The IMDCT overlap-and-add buffer,  $y_{ov}(n)$

**Processing:** Figure 4.13-1 depicts the Generic Audio encoding system that is described in the following sections. Some of the processing functions are common to the Rate 1 RCELP processing, but are included again here for completeness.

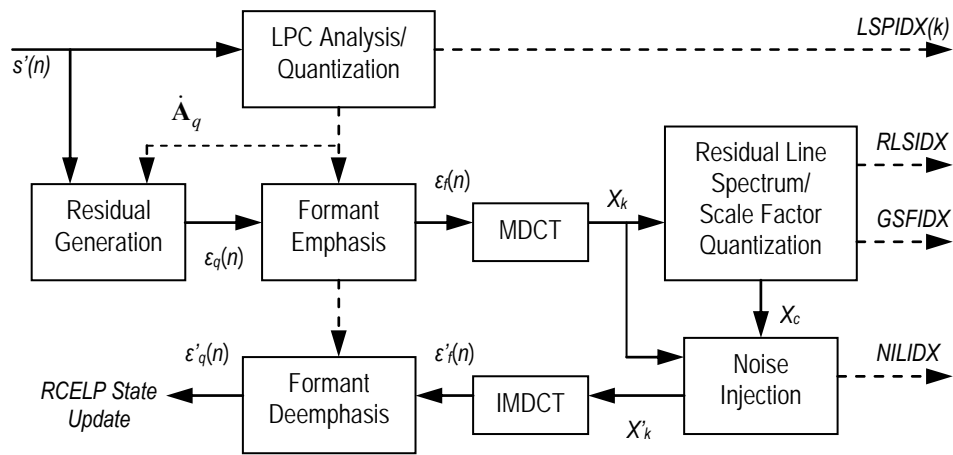

**Figure 4.13-1 Rate 1 Generic Audio Encoding Block Diagram**

4.13.1 LPC Analysis/Quantization

The LPC Analysis is identical to that used in the Model Parameter Estimation routines in 4.6.1. The resulting LSP parameters are quantized using the Rate 1 quantizer given in 4.10.2.

4.13.2 Short-Term Residual Generation

The short-term residual is calculated in the same way as in 4.6.2, except that the quantized LSPs  $\Omega_q$  are used. The short-term residual signal is designated as  $\epsilon_q(n)$ ;  $0 \leq n < 320$ .

### 1 4.13.3 Formant Emphasis

2 The formant emphasis filter places perceptual weighting on the low frequency formant regions of the short-term  
3 residual signal. The transfer function of the filter is given as:

$$4 \quad H_f(z) = \frac{1 + \mu_f z^{-1}}{\dot{A}_q(\gamma_f^{-1} z)} \quad (4.13.3-1)$$

5 where  $\mu_f = 0.2$  is the tilt coefficient,  $\gamma_f = 0.4$  is the formant emphasis coefficient, and  $\dot{A}_q$  is the set of  
6 interpolated LPC coefficients derived in the same manner as in 4.11.4.1 and 4.11.4.2 for the perceptual  
7 weighting filter. The filter is applied to the short term residual  $\varepsilon_q(n)$  in a zero-state manner to produce the  
8 formant weighted residual  $\varepsilon_f(n)$ ;  $0 \leq n < 320$ .

### 9 4.13.4 Modified Discrete Cosine Transform (MDCT)

10 First, a modified sine window is defined as:

$$11 \quad w(n) = \begin{cases} \sin\left(\frac{\pi}{160}\left(n + \frac{1}{2}\right)\right) & ; 0 \leq n < 80 \\ 1 & ; 80 \leq n < 160 \\ \sin\left(\frac{\pi}{160}\left(n - 80 + \frac{1}{2}\right)\right) & ; 160 \leq n < 240 \end{cases} \quad (4.13.4-1)$$

12 This window is applied to the formant weighted residual signal such that the first 160 samples correspond to the  
13 current frame of the residual  $\varepsilon_f(n)$ ;  $80 \leq n < 240$ , and the last 80 samples of the window correspond to the  
14 look-ahead portion of the residual  $\varepsilon_f(n)$ ;  $240 \leq n < 320$ . The MDCT frame  $x_n$  is thus formulated as:

$$15 \quad x_n = \begin{cases} 0 & ; 0 \leq n < 40 \\ w(n-40)\varepsilon_f(n+40) & ; 40 \leq n < 280 \\ 0 & ; 280 \leq n < 320 \end{cases} \quad (4.13.4-2)$$

16 and the MDCT coefficients are then obtained as follows:

$$17 \quad X_k = \frac{2}{\sqrt{320}} \sum_{n=0}^{319} x_n \cos\left[\frac{\pi}{160}\left(n + \frac{1}{2} + 80\right)\left(k + \frac{1}{2}\right)\right]; 0 \leq k < 160. \quad (4.13.4-3)$$

### 18 4.13.5 MDCT Residual Line Spectrum Quantization

19 The MDCT coefficients, referred to as the residual line spectrum, are quantized in a similar manner to the FCB  
20 factorial codebook of 4.11.8.3. Basically, factorial coding of  $N = {}^n FPC_m$  possible combinations can be  
21 achieved given that the length  $n$  vector  $\mathbf{v}$  has the properties  $m = \sum_{i=0}^{n-1} |v_i|$  and all elements  $v_i$  are integral  
22 valued. That is, the sum of the absolute value of the integer elements of  $\mathbf{v}$  is equal to  $m$ . For this case, we wish  
23 to code an energy scaled version of  $X_k$  such that:

$$m = \sum_{k=0}^{143} |\text{round}\{\gamma_m X_k\}|, \quad (4.13.5-1)$$

where  $\gamma_m$  is a global scale factor, and the range 0 to 143 corresponds to the frequency range 0 to 3600 Hz. For this case,  $m$  can be either 28 for NB or 23 for WB inputs. The value of  $\gamma_m$  used to achieve the above objective is determined iteratively (for non-zero  $\|X_k\|^2$ ) according to the following pseudo-code:

```

1  /* Initialization */
2   $e_{min} = -100, e_{max} = 20$ 
3   $e = \max\{e_{min}, -10 \log_{10}(\|X_k\|^2)/1.2\}$ 
4   $s = +1, \Delta_e = 8$ 
5
6  /* main loop */
7  do {
8       $\gamma_m = 10^{e/20}$ 
9       $m' = \sum_{k=0}^{143} |\text{round}\{\gamma_m X_k\}|$ 
10     if  $(m' == m)$  then break
11     else if  $(m' > m \text{ and } s == +1)$  then  $s = -1, \Delta_e = \Delta_e / 2$ 
12     else if  $(m' < m \text{ and } s == -1)$  then  $s = +1, \Delta_e = \Delta_e / 2$ 
13     end
14      $e = e + s \cdot \Delta_e$ 
15 } while  $e \leq e_{max}$  and  $\Delta_e \geq \Delta_{min}$ 

```

The quantized residual line spectrum  $X_{cc}$  is then calculated as:

$$X_{cc}(k) = \begin{cases} \text{round}\{\gamma_m X_k\} & ; 0 \leq k < 144 \\ 0 & ; 144 \leq k < 160 \end{cases}, \quad (4.13.5-2)$$

If, on the rare occasion, the values of  $m$  and  $m'$  are different, the line spectrum shall be modified by adding or subtracting unit values to the quantized line spectrum  $X_{cc}$ . This guarantees that the resulting line spectrum can be reliably coded using the factorial coding method. The output index representing the line spectrum  $X_{cc}$  is designated *RLSIDX*. This index comprises 131 bits for the  $^{144}FPC_{28}$  case and 114 bits for the  $^{144}FPC_{23}$  case.

In order to address complexity issues associated with encoding and decoding vector  $X_{cc}$ , a low resolution combinatorial approximation function  $F'(n, r)$  shall be used in place of the standard combinatorial relation  $F(n, r) = {}^n C_r = n! / r!(n-r)!$ . In particular, both the encoder and decoder utilize a combinatorial function generator  $F'(n, r)$  having the properties  $F'(n, r) \geq F(n, r)$  and  $F'(n, r) \geq F'(n-1, r) + F'(n-1, r-1)$ , which are sufficient to uniquely encode/decode vector  $X_{cc}$ . The function  $F'(n, r)$  is given as:

$$F'(n, r) = R' \left( \sum_{i=n-r+1}^n P(i) - Q'(r) \right), \quad (4.13.5-3)$$

1 where  $P'(i)$  and  $Q'(r)$  are 32 bit lookup tables given as:

$$2 \quad P'(i) = 2^{-21} \lfloor 2^{21} \log_2(i) + 1 \rfloor, \quad i \in [1, 2, \dots, 144] \quad (4.13.5-4)$$

3 and

$$4 \quad Q'(r) = \begin{cases} 0, & r = 1 \\ \sum_{j=2}^r 2^{-14} \lfloor 2^{14} \log_2(j) - 1 \rfloor & r \in [2, \dots, 28], \end{cases} \quad (4.13.5-5)$$

5 and where  $R'(k)$  is a multi-precision integer approximation of the function  $R'(k) \approx 2^k$ , given as:

$$6 \quad R'(k) = \lfloor 2^{k_i - 19} \lfloor 2^{19} K_f \rfloor \rfloor, \quad (4.13.5-6)$$

7 where  $k = k_i + k_f$  is broken down into integer and fractional components of  $k$ , and  $K_f = 2^{k_f}$  is a Taylor series  
8 expansion of the fractional component of  $k$ . These operations significantly reduce the complexity necessary in  
9 calculating the combinatorial expressions by replacing multi-precision multiply and divide operations with 32  
10 bit additions and a low complexity Taylor series approximation of  $2^k$  followed by a multiprecision shift  
11 operation. All other components of the encoding/decoding operations are identical to that in 4.11.8.3.

#### 12 4.13.6 Global Scale Factor Quantization

13 The log domain scale factor is first recalculated based on the normalized cross correlation between the  
14 quantized line spectrum  $X_{cc}$  and the residual line spectrum  $X_k$ , or:

$$15 \quad e_{sf} = -20 \log_{10} \left[ \frac{\sum_{k=0}^{143} X_{cc}(k) X_k}{\sum_{k=0}^{143} X_{cc}^2(k)} \right]. \quad (4.13.6-1)$$

16 The log domain scale factor  $e_{sf}$  is then quantized using a uniform distribution scalar quantizer to produce  $e_q$ ,  
17 such that the global scale factor index is obtained by minimizing the following:

$$18 \quad GSFIDX = \arg \min_{0 \leq i \leq 127} \left\{ \left| e_{sf} - (e_{q \min} + e_{bias} + i \Delta_{eq}) \right| \right\}, \quad (4.13.6-2)$$

19 where  $\Delta_{eq} = (e_{q \max} - e_{q \min}) / 127$  is the quantizer step size,  $e_{q \min} = -95$  is the minimum quantizer level,  
20  $e_{q \max} = -25$  is the maximum quantizer level, and  $e_{bias}$  is the energy bias term given by:

$$21 \quad e_{bias} = 10 \log_{10} \left( \sum_{k=0}^{143} X_{cc}^2(k) \right). \quad (4.13.6-3)$$

22 The quantized scale factor is ultimately given as:

$$23 \quad e_q = e_{q \min} + e_{bias} + GSFIDX \cdot \Delta_{eq}, \quad (4.13.6-4)$$

1 which is then applied to the quantized residual line spectrum  $X_{cc}$  to obtain the coded residual line spectrum  $X_c$ ,  
 2 given as:

$$3 \quad X_c = 10^{-e_q/20} X_{cc}. \quad (4.13.6-5)$$

#### 4 4.13.7 Noise Injection

5 The noise injection process provides improved audio quality by reducing the perception of tonal artifacts that  
 6 may occur during undermodeling of the residual line spectrum. The noise injection process substitutes noise  
 7 for zero valued elements of the coded residual line spectrum within a predetermined frequency range. The  
 8 noise injection level (gain) is based on the ratio of the uncoded energy in the original residual line spectrum  $X_k$   
 9 to the total energy of the original line spectrum, and is coded using only 2 bits. This processed is described  
 10 below.

11 A zero detection mask is first produced to control whether or not regions of the scaled line spectrum shall be  
 12 injected with noise. The mask is represented as a 160 element column vector  $\mathbf{z}_d$  that is defined as:

$$13 \quad z_d(k) = \begin{cases} 1; & 40 \leq k \leq 143 \text{ and } X_c(k) == 0 \\ 0; & \text{otherwise} \end{cases}. \quad (4.13.7-1)$$

14 The noise injection gain  $\gamma_{ni}$  is then calculated using the zero detection control mask and the original residual  
 15 line spectrum  $X_k$ , such that:

$$16 \quad \gamma_{ni} = 0.9 \sqrt{\frac{\sum_{k=40}^{143} z_d(k) X_k^2}{\sum_{k=40}^{143} X_k^2}}. \quad (4.13.7-2)$$

17 The noise injection gain is then quantized using a 2 bit lookup table, defined as  $\gamma_{ni\_table} = [0.15, 0.30, 0.45,$   
 18  $0.60]$ , so that:

$$19 \quad NILIDX = \arg \min_{0 \leq i \leq 3} \left\{ \left| \gamma_{ni} - \gamma_{ni\_table}[i] \right| \right\}, \quad (4.13.7-3)$$

20 where  $NILIDX$  is the noise injection level index. The noise injection gain is then redefined as  
 21  $\gamma_{ni} \leftarrow \gamma_{ni\_table}[NILIDX]$ , and subsequently used to generate the noise injected residual line spectrum  $X'_k$  as:

$$22 \quad X'_k = \begin{cases} \gamma_{ni} 10^{-e_q/20} \text{rand}(); & 40 \leq k \leq 143 \text{ and } z_d(k) == 1 \\ X_c(k); & \text{otherwise} \end{cases}, \quad (4.13.7-4)$$

23 where  $\text{rand}()$  is a uniform random number spanning  $[-0.5, 0.5]$ . To ensure the encoder and decoder are  
 24 synchronized, the random number generator is seeded using the residual line spectrum index,  $RLSIDX$ .

#### 25 4.13.8 Inverse Modified Discrete Cosine Transform (IMDCT)

26 Encoder signal reconstruction is required to properly update the RCELP state memories. More specifically, the  
 27 Adaptive Codebook and Zero Input Response filter require update in the event that next frame is an RCELP

1 Rate 1 or Rate 1/2 frame type. Therefore, the following processes are required to generate the residual domain  
2 excitation signals.

3 The formant weighted residual estimate is obtained by applying the inverse MDCT to  $X'_k$  as:

$$4 \quad y_n = \frac{2}{\sqrt{320}} \sum_{k=0}^{159} X'_k \cos \left[ \frac{\pi}{160} \left( n + \frac{1}{2} + 80 \right) \left( k + \frac{1}{2} \right) \right]; 0 \leq k < 320. \quad (4.13.8-1)$$

5 and then widowing and overlap-adding the previous frame's IMDCT output to produce the reconstructed  
6 formant weighted residual:

$$7 \quad \varepsilon'_f(n) = \begin{cases} y_{ov}(n) + w(n)y_n(n+40) & ; 0 \leq n < 80 \\ y_n(n+40) & ; 80 \leq n < 160 \end{cases} \quad (4.13.8-2)$$

8 In the event that the previous frame was not a Generic Audio frame type, then the IMDCT overlap-add buffer is  
9 set to all zeros. The IMDCT overlap-add buffer is updated for the next frame as:

$$10 \quad y_{ov}(n) = w(n+160)y_n(n+200) \quad ; 0 \leq n < 80. \quad (4.13.8-3)$$

#### 11 4.13.9 Formant Deemphasis

12 The formant deemphasis filter removes the perceptual weighting previously put on the low frequency formant  
13 regions of the short-term residual signal. The transfer function of the filter is given as:

$$14 \quad H_d(z) = H_f^{-1}(z) = \frac{\dot{A}_q(\gamma_f^{-1}z)}{1 + \mu_f z^{-1}} \quad (4.13.9-1)$$

15 The filter is applied to the reconstructed formant weighted residual  $\varepsilon'_f(n)$  to produce the reconstructed short-  
16 term residual signal  $\varepsilon'_q(n); 0 \leq n < 160$ . In the event that the previous frame was not a Generic Audio frame  
17 type, then the formant deemphasis filter memory is set to all zeros. The signal  $\varepsilon'_q(n); 0 \leq n < 160$  is then used  
18 to update the RCELP state memories described in 4.11.4.15.

#### 19 4.14 Encoding at Rate 1/4 unvoiced for SO 68 and Rate 1/2 unvoiced for SO 70 WB

20 NELP is used for Rate 1/4 unvoiced frames in SO 68 and Rate 1/2 unvoiced frames in SO 70 WB. A pseudo-  
21 random noise is colored using a set of filters, and scaled appropriately by gains in 10 subframes of 16 samples  
22 each to model the excitation.

23

24

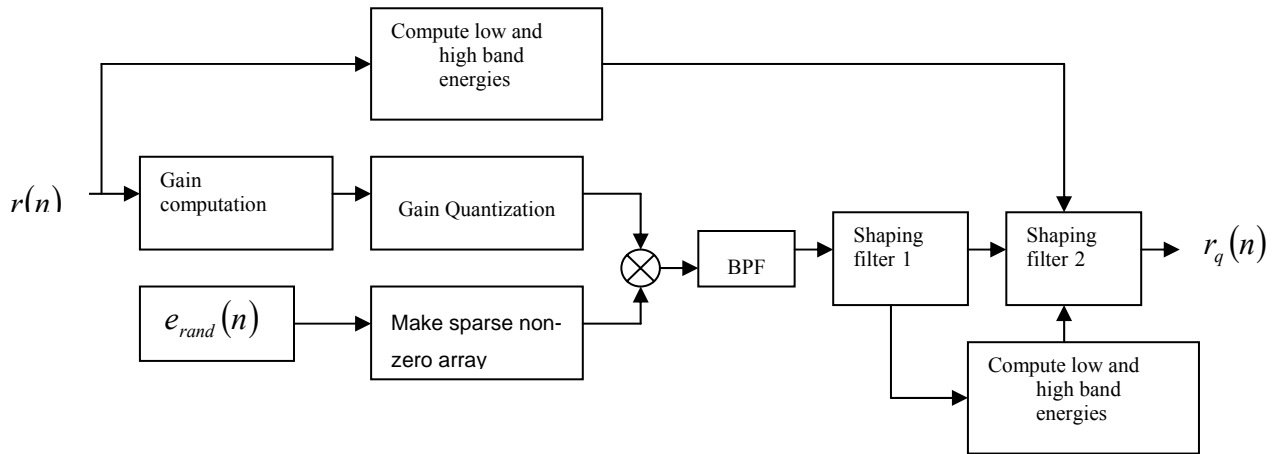

Figure 4.14-1 Excitation coding for Rate 1/4 unvoiced frames for SO 68 and Rate 1/2 unvoiced frames for SO 70 WB

4.14.1 Computation and quantization of gains

**Input**

Residual,  $r(n)$

Quantized LSFs,  $lsf_1^q(i)$

**Output**

Quantized excitation,  $r_q(n)$

The energy  $E_i$  of the residual signal is computed for each of the 10 subframes ( $0 \leq i < 10$ ) as

$$E_i = \frac{1}{16} \sum_{n=16i}^{16i+15} r^2(n) \tag{4.14.1-1}$$

The 10 subframe gains  $G_i$  are computed from the above energies as

$$G_i = \sqrt{E_i} \tag{4.14.1-2}$$

Two normalization factors for two splits ( $0 \leq j < 2$ ) of the above 10 gains are determined by

$$G'[j] = \sqrt{\frac{1}{5} \sum_{i=0}^4 G_{j*5+i}^2} \tag{4.14.1-3}$$

1 The above two normalization factors are vector quantized using a two dimensional codebook  $UVG1CB[32][2]$   
 2 to provide an index  $i\hat{G}'$  as

$$3 \quad i\hat{G}' = \arg \min_k \left( \sum_{j=0}^1 (\log_{10}(G'[j]) - UVG1CB[k][j])^2 \right), \quad 0 \leq k < 32 \quad (4.14.1-4)$$

4 The quantized normalization factors are then computed for  $(0 \leq j < 2)$  using

$$5 \quad \hat{G}'[j] = 10^{UVG1CB[i\hat{G}'][j]} \quad (4.14.1-5)$$

6 The 10 subframe gains are then normalized using the quantized normalization factors according to

$$8 \quad G''[2j+i] = \frac{G[2j+i]}{\hat{G}'[j]}, \quad 0 \leq i < 5, 0 \leq j < 2 \quad (4.14.1-6)$$

9  
 10 The 10 normalized gains are then vector quantized using a 3-dimensional codebook  $UVG2CB[2][64][5]$  to  
 11 provide two indices  $iG''[0]$ , and  $iG''[1]$  such that

$$13 \quad i\hat{G}''[j] = \arg \min_k \left( \sum_{i=0}^4 (G''[2j+i] - UVG2CB[j][k][i])^2 \right); \quad 0 \leq k < 64; 0 \leq j < 2 \quad (4.14.1-7)$$

14 The quantized, normalized gains are then given by

$$16 \quad \hat{G}''[2j+i] = UVG2CB[j][i\hat{G}''][i]; \quad 0 \leq i < 5, 0 \leq j < 2 \quad (4.14.1-8)$$

17 The quantized gains used to scale the NELP excitation then are

$$19 \quad \hat{G}[2j+i] = \hat{G}'[j] \hat{G}''[2j+i], \quad 0 \leq i < 5, 0 \leq j < 2 \quad (4.14.1-9)$$

#### 20 4.14.2 Random number generation

21 A pseudo-random vector  $e_{rand}$  of 160 samples is generated as follows,

$$22 \quad e_{rand}(n) = \begin{cases} NELPseed, & \text{where} \\ NELPseed = (521 \times NELPseed + 259) / 32768; & 0 \leq n < 160 \end{cases} \quad (4.14.2-1)$$

23 For Rate 1/4, the seed,  $NELPseed$ , is initialized at the beginning of each frame to a signed 16-bit number that is  
 24 derived from the bits representing the LSF.

## 1 4.14.3 Creation of sparse nonzero excitation

2 The above pseudo-random vector  $e_{rand}(n)$  is divided into 10 subframes, and each subframe is made sparse by  
 3 retaining the 4 largest absolute magnitude samples, and zeroing out the remaining 12. Each of these 10  
 4 subframes of the sparse vectors is denoted by  $e_{sparse}(i, n)$ ,  $0 \leq i < 10$ ;  $0 \leq n < 16$ . These sparse vectors are then  
 5 scaled by their appropriate gains to create 160 samples of a sparse, excitation signal

$$6 \quad r_1(16i + n) = \sqrt{3}\hat{G}(i)e_{sparse}(i, n), \quad 0 \leq i < 10; 0 \leq n < 16 \quad (4.14.3-1)$$

## 7 4.14.4 Shaping the excitation

8 The above excitation  $r_1(n)$  is filtered by a 12th order bandpass filter, in order to remove the low band and high  
 9 components to yield the signal  $r_2(n)$ . This bandpass filter is given by the following transfer function

$$10 \quad BP(z) = \frac{BP_{n0} + BP_{n1}z^{-1} + \dots + BP_{n12}z^{-12}}{1 + BP_{d1}z^{-1} + \dots + BP_{d12}z^{-12}} \quad (4.14.4-1)$$

11 where the coefficients  $BP_{ni}$ , and  $BP_{di}$  are given in the tables bp1\_num\_coef, and bp1\_den\_coef respectively in  
 12 the C-code.

13  $r_2(n)$  is then filtered by the 10th order shaping filter  $SF1(z)$  to give the signal  $r_3(n)$ . This shaping filter is  
 14 given by the following transfer function

$$15 \quad SF1(z) = \frac{SF1_{n0} + SF1_{n1}z^{-1} + \dots + SF1_{n12}z^{-10}}{1 + SF1_{d1}z^{-1} + \dots + SF1_{d12}z^{-10}} \quad (4.14.4-2)$$

16 where the coefficients  $SF1_{ni}$ , and  $SF1_{di}$  are given in the tables shapel\_num\_coef, and shapel\_den\_coef  
 17 respectively in the C-code.

18  $r_3(n)$  is then scaled according to the following equation to yield

$$19 \quad r_4(n) = \left( \frac{\sqrt{\sum_{n=0}^{159} [r(n)]^2}}{\sqrt{\sum_{n=0}^{159} [r_3(n)]^2}} \right) r_3(n) \quad (4.14.4-3)$$

20  $r(n)$  and  $r_4(n)$  are filtered by the 10th order lowpass filter  $LP(z)$  to give  $r_L(n)$  and  $r_{4L}(n)$ . Similarly,  $r(n)$   
 21 and  $r_4(n)$  are filtered by the 10th order highpass filter  $HP(z)$  to give  $r_H(n)$  and  $r_{4H}(n)$ .

$$22 \quad LP(z) = \frac{LP_{n0} + LP_{n1}z^{-1} + \dots + LP_{n12}z^{-10}}{1 + LP_{d1}z^{-1} + \dots + LP_{d12}z^{-10}} \quad (4.14.4-4)$$

$$HP(z) = \frac{HP_{n0} + HP_{n1}z^{-1} + \dots + HP_{n12}z^{-10}}{1 + HP_{d1}z^{-1} + \dots + HP_{d12}z^{-10}} \quad (4.14.4-5)$$

where the coefficients  $LP_{ni}$ , and  $LP_{di}$  are given in the tables `txlpf1_num_coef`, and `txlpf1_den_coef` respectively in the C-code, and the coefficients  $HP_{ni}$ , and  $HP_{di}$  are given in the tables `txhpf1_num_coef`, and `txhpf1_den_coef` respectively in the C-code.

Two factors  $R_L$ , and  $R_H$  are computed as follows

$$R_L = 10 \log_{10} \left( \frac{\sum_{n=0}^{n=159} [r_L(n)]^2}{\sum_{n=0}^{n=159} [r_{4L}(n)]^2} \right) \quad (4.14.4-6)$$

and

$$R_H = 10 \log_{10} \left( \frac{\sum_{n=0}^{n=159} [r_H(n)]^2}{\sum_{n=0}^{n=159} [r_{4H}(n)]^2} \right) \quad (4.14.4-7)$$

A filter index  $F_{idx}$  is computed as follows from  $R_L$ , and  $R_H$ , and sent to the decoder.

$$F_{idx} = \begin{cases} 1 & ; R_L < -3 \\ 2 & ; R_L \geq -3 \text{ and } R_H < -3 \\ 0 & ; \textit{otherwise} \end{cases} \quad (4.14.4-8)$$

The shaping filter  $SF(z)$  is determined from  $F_{idx}$  as follows

$$SF(z) = \begin{cases} SF1(z) & ; F_{idx} = 0 \\ SF1(z)SF2(z) & ; F_{idx} = 1 \\ SF1(z)SF3(z) & ; F_{idx} = 2 \end{cases} \quad (4.14.4-9)$$

where,  $SF2(z)$ ,  $SF3(z)$  are

$$SF2(z) = \frac{SF2_{n0} + SF2_{n1}z^{-1} + \dots + SF2_{n12}z^{-10}}{1 + SF2_{d1}z^{-1} + \dots + SF2_{d12}z^{-10}} \quad (4.14.4-10)$$

$$SF3(z) = \frac{SF3_{n0} + SF3_{n1}z^{-1} + \dots + SF3_{n12}z^{-10}}{1 + SF3_{d1}z^{-1} + \dots + SF3_{d12}z^{-10}} \quad (4.14.4-11)$$

1 where the coefficients  $SF2_{ni}$ ,  $SF2_{di}$ ,  $SF3_{ni}$ , and  $SF3_{di}$  are given in the tables `shape2_num_coef`,  
 2 `shape2_den_coef`, `shape3_num_coef`, and `shape3_den_coef` respectively in the C-code.  
 3 Finally,  $r_3(n)$  is filtered by  $SF(z)$  to provide the quantized formant residual  $r_q(n)$  for the Rate 1/4 frame.

#### 4 4.14.5 Perceptual weighting filter update

5 Although there is no closed-loop search at Rate ¼ unvoiced coding, it is still necessary to update the memory of  
 6 the perceptual weighting filter with the new excitation determined in 4.6.7 for each subframe. Update the  
 7 weighted synthesis filter memory by filtering the excitation vector,  $E(n)$ , through the weighted synthesis filter,  
 8  $Hwq(z)$ , which is given in Equation 4.11.4-5.

9

### 10 4.15 Encoding at Rate 1/8

11 **Inputs:** The inputs to Rate 1/8 encoding are:

- 12 • The unquantized LSPs from the current and previous frames,  $\Omega(m)$  and  $\Omega(m-1)$
- 13 • The quantized LSPs from the previous frame,  $\Omega_q(m-1)$
- 14 • The short-term prediction residual,  $\varepsilon(n)$

15 **Outputs:** The outputs of Rate 1/8 encoding are:

- 16 • The quantized LSPs for the current frame,  $\Omega_q(m)$
- 17 • The quantization index corresponding to these LSPs,  $LSPIDX(k)$
- 18 • The vector quantized frame energy index,  $FGIDX$

19 **State Variables Affected:**

- 20 • The accumulated shift counter,  $\tau_{acc}$ , is set to 0
- 21 • The pointer to the last element in shifted residual,  $n_m$ , is set to 0

22 **Processing:** Rate 1/8 encoding shall comprise 4.15.1 to 4.15.11.

#### 23 4.15.1 LSP Quantization

24 Vector quantize the unquantized LSPs,  $\Omega(m)$ , using the procedure found in 4.9 for Rate 1/8.

#### 25 4.15.2 Interpolation of LSP Parameters

26 Interpolate the quantized LSPs over the three subframes,  $m'$ , in the current frame,  $m$ , as defined in 4.6.2.1.

#### 27 4.15.3 LSP to LPC Conversion

28 Convert the quantized, interpolated LSPs,  $\dot{\Omega}_q(m)$ , to quantized, interpolated LPC parameters,  $\left\{ \dot{a}_q \right\}$ , as  
 29 described in Section 4.6.2.2 for each subframe.

## 1 4.15.4 Impulse Response Computation

2 Calculate the unweighted impulse response,  $h(n)$ , of  $1/A_q(z)$  to 54 terms for each subframe, where  $A_q(z)$  is  
3 defined as:

$$4 \quad A_q(z) = 1 - \sum_{i=1}^{10} a_q(i)z^{-i} \quad (4.15.4-1)$$

## 5 4.15.5 Calculation of the Frame Energy Gain for SO 3

6 The frame energy gain is defined as the ratio of the energy of the impulse response to the mean of the residual  
7 for each subframe  $m'$ :

$$8 \quad \gamma(m') = \frac{E_\varepsilon(m')}{E_h(m')}, \quad (4.15.5-1)$$

9 where the energy of the impulse response is given by:

$$10 \quad E_h(m') = \sqrt{\sum_{i=0}^{L-1} h^2(n)}, \quad (4.15.5-2)$$

11 and the mean  $E_\varepsilon(m')$  of the residual signal  $\varepsilon(n)$  is defined as:

$$12 \quad E_\varepsilon(m') = \max \left\{ 1, \frac{1}{L} \sum_{i=0}^{L-1} |\varepsilon(n)| \right\}, \quad (4.15.5-3)$$

13 where  $L$  is the subframe size (53 for subframes 0 and 1, 54 for subframe 2),  $n = 0$  is defined as the index of the  
14 first sample in the current subframe, and  $\varepsilon(n)$  is the residual at the current subframe.

## 15 4.15.6 Gain Quantization for SO 3

16 The gain vector,  $\gamma(m')$ , shall be quantized to 8 bits using a vector quantizer. The quantizer will assign one  
17 index for the best three-element gain vector corresponding to  $\gamma(m')$ . The best vector is found by calculating the  
18 error vector,  $e_g(k)$ , as defined by:

$$19 \quad e_g(k) = \sum_{m'=0}^2 \left( \log_{10}(\gamma(m')) - q_{\log}(m', k) \right)^2, \quad (4.15.6-1)$$

20 where  $q_{\log}(m', k)$  is an entry in the gain quantization codebook found in Table 9-18.  
21 The best codebook index,  $FGIDX$ , is defined as the index,  $k$ , at which  $e_g(k)$  is minimized.  
22 This codebook index,  $FGIDX$ , shall be used to determine a set of quantized gains  $\gamma_q(m')$ :

$$23 \quad \gamma_q(m') = 10^{q_{\log}(m', FGIDX)}, \quad 0 \leq m' < 3 \quad (4.15.6-2)$$

1 4.15.7 Calculation of the frame energy gain

2 The mean  $E_{\varepsilon}(m')$  of the residual signal  $\varepsilon(n)$  is defined as:

3 
$$E_{\varepsilon}(m') = \max \left\{ 1, \frac{1}{L} \sum_{i=0}^{L-1} |\varepsilon(n)| \right\}, \quad (4.15.7-1)$$

4 where L is the subframe size (53 for subframes 0 and 1, 54 for subframe 2), n = 0 is defined as the index of the  
5 first sample in the current subframe, and  $\varepsilon(n)$  is the residual at the current subframe.

## 1 4.15.8 Gain quantization for SO 68 and SO 70 NB mode

2 The gain shall be quantized to 6 bits using a scalar quantizer. The best gain index is found by minimizing the  
 3 error, eg, as defined by:

$$FGIDX = \arg \min_i \left( \log \left( \max_{m'} (E_i(m')) \right) - \left( MINLOGE + i \cdot \left( \frac{MAXLOGE - MINLOGE}{NUMQLEVELS} \right) \right) \right)$$

4  
 5

6 (4.15.8-1)

7 where  $0 \leq i < NUMQLEVELS$ , the indices of gain quantization, and MINLOGE is 0.2, MAXLOGE is 2.6, and  
 8 NUMQLEVELS is 64;

9 .

10

11 This codebook index, FGIDX, shall be used to determine a frame gain  $\gamma_q$ :

$$\gamma_q(m') = 10^{q \log(m', FGIDX)}; \quad 0 \leq m' < 3$$

12

(4.15.8-2)

$$\gamma_q = 10^{MINLOGE + FGIDX \cdot \left( \frac{MAXLOGE - MINLOGE}{NUMQLEVELS} \right)}$$

13

(4.15.8-3)

14 And the set of 3 subframe gains are given by

$$\gamma_q(m') = \begin{cases} \frac{2}{3} \gamma_q^{last} + \frac{1}{3} \gamma_q; & m' = 0 \\ \frac{1}{3} \gamma_q^{last} + \frac{2}{3} \gamma_q; & m' = 1 \\ \gamma_q; & m' = 2 \end{cases}$$

15

(4.15.8-4)

## 1 4.15.9 Gain quantization for SO 70 WB mode

2 The gain shall be quantized to 5 bits using a scalar quantizer. The best gain index is found by minimizing the  
3 quantization error, as defined by:

$$4 \quad FGIDX = \arg \min_i \left( \frac{1}{2} \log \left( 1 + \frac{1}{4} \sum_{n=80}^{239} (s'(n))^2 \right) - \left( MINLOGE_{wb} + i \cdot \left( \frac{MAXLOGE_{wb} - MINLOGE_{wb}}{NUMQLEVELS_{wb}} \right) \right) \right),$$

5 (4.15.9-1)

6 where  $0 \leq i < NUMQLEVELS_{wb}$ , the indices of gain quantization, and  $MINLOGE_{wb} = 2.0$ ,  $MAXLOGE_{wb} =$   
7  $12.0$ , and  $NUMQLEVELS_{wb} = 32$ . The frame gain used for subsequent eighth rate encoder processing is  
8  $\gamma_q = 0$ .

9

## 10 4.15.10 Generation of Rate 1/8 Excitation

11 The excitation for each subframe at Rate 1/8 is generated by using a zero-mean, unit variance pseudo-Gaussian  
12 white noise sequence which is scaled by the quantized frame energy gain  $\gamma_q(m')$  for each subframe  $m'$ :

$$13 \quad E(n) = \gamma_q \text{ran\_g}\{seed\}; \quad 0 \leq n < L,$$

14 (4.15.10-1)

14 where  $\text{ran\_g}\{seed\}$  is the unit variance pseudo-random Gaussian white noise generator (see 4.16.2) and  $seed$  is  
15 a unique seed value defined at reset of the system.

## 16 4.15.11 Perceptual Weighting Filter Update

17 Although there is no closed-loop search at Rate 1/8, it is still necessary to update the memory of the perceptual  
18 weighting filter with the new excitation determined in 4.15.10 for each subframe. Update the weighted  
19 synthesis filter memory by filtering the excitation vector,  $E(n)$ , through the weighted synthesis filter,  $H_{wq}(z)$ ,  
20 which is given in Equation 4.11.4-5.

21 **4.16 Random Number Generation**

22 Zero mean, unit variance gaussian pseudo-random numbers are obtained by generating uniform pseudo-random  
23 numbers and appropriately transforming them. The following two sub-sections describe the uniform pseudo-  
24 random number generator and the algorithm for effecting the uniform to gaussian transformation.

## 25 4.16.1 Uniform Pseudo-Random Number Generation Algorithm

26 The algorithm for generating the uniform pseudo-random numbers is initialized with a seed value, and produces  
27 a new seed value with each successive invocation, as well as producing the desired pseudo-random number.  
28 The state of the uniform random number generator is captured by the current value of the seed. Different  
29 modules making use of the random number generator should maintain their own seeds. Uniform pseudo-  
30 random numbers are generated as follows:

1 **Inputs:** The input to the uniform number generator is:

- 2 • The seed value, *seed0*

3 **Outputs:** The outputs of the uniform pseudo-random number generator are:

- 4 • The uniform pseudo-random number, *ran0*
- 5 • The modified seed value, *newseed0*

6 **Processing:** Uniform pseudo-random number generation is accomplished as described in the following  
7 pseudo-code:

```
8     newseed0 = seed0 ⊕ 23148373
9     temp = trunc(newseed0 / 127773)
10    newseed0 = 16807 * (newseed0 - temp * 127773) - 2836 * temp
11    if(newseed0 < 0)
12        newseed0 = newseed0 + 2147483647
13    ran0 = newseed0 / 2147483647
14    newseed0 = seed0 ⊕ 23148373
```

15

#### 16 4.16.2 Gaussian Pseudo-Random Number Generator

17 The gaussian pseudo-random number generator makes use of the uniform pseudo-random number generator  
18 described in 4.16.1. Gaussian pseudo-random numbers are generated in pairs. While the algorithm that  
19 performs the transformation from uniform to gaussian does not itself have any memory, the values produced by  
20 it are a function of the seed value, which is used in invocations of the uniform pseudo-random number  
21 generator described in 4.16.1. Consequently, it is important for each module that makes use of the random  
22 number generator to maintain its own seed value. The transformation from uniform to gaussian is described as  
23 follows:

24 **Inputs:** The input to the gaussian pseudo-random number generator is

- 25 • The seed value, *seed*

26 **Outputs:** The outputs of the gaussian pseudo-random number generator are:

- 27 • The pair of gaussian pseudo-random numbers generated, *ran\_g0* and *ran\_g1*
- 28 • The new value of the seed, *newseed*.

29 **Processing:** Generation of gaussian pseudo-random numbers is described in the following pseudocode. Note  
30 that *ran\_u0* and *ran\_u1* are the uniform pseudo-random numbers produced by two different invocations of the  
31 algorithm of 4.16.1, and *newseed0* and *newseed1* are the new seed values produced by each of these respective  
32 invocations. Each invocation of the uniform pseudo-random number generator uses the current value of *seed* as  
33 its input.

```
34     do {
35         v1 = 2.0 * ran_u0 - 1.0
36         seed = newseed0
37         v2 = 2.0 * ran_u1 - 1.0
38         seed = newseed1
39         rsq = v1 * v1 + v2 * v2
40     } while (rsq >= 1.0 OR rsq == 0.0)
```

1  $fac = (-2.0 * \log(rsq) / rsq)^{1/2}$   
 2  $ran\_g0 = v1 * fac$   
 3  $ran\_g1 = v2 * fac$   
 4

#### 5 4.17 Discontinuous Transmission

6 DTX implementation of EVRC-A follow the requirements in [N2]. EVRC-B has a native Discontinuous  
 7 Transmission or DTX scheme. When DTX is enabled, the EVRC-B encoder doesn't transmit Rate 1/8 frame  
 8 every 20 ms during VAD = 0, but only sends eighth-rate frame infrequently. At the end of a talk spurt (defined  
 9 by the use of a Rate 1 or Rate 1/2 or Rate 1/4 frame), the first Rate 1/8 frame is transmitted. Subsequently, all  
 10 following Rate 1/8 frames are blanked and not transmitted. If there is an appreciable change in the Rate 1/8  
 11 frame indicating a significant change in the background noise characteristic, another Rate 1/8 frame is sent.  
 12 This change is calculated by comparing gain of the eighth-rate frame with a running average of eighth-rate  
 13 frame energies. If the change is larger than a threshold, then an eighth-rate frame is transmitted. Similarly, the  
 14 LSPs of the eighth-rate frame is compared with the LSPs of the last transmitted eighth-rate frame. If the change  
 15 is greater than a threshold an eighth-rate frame is transmitted, otherwise an eighth-rate frame is transmitted  
 16 according to the "DTX max" parameter in [N2]. In addition to the above mentioned adaptive decision to  
 17 transmit an eighth-rate frame, the DTX implementation of EVRC-B also follows the requirements in [N2]  
 18 including the default values.

19 When a decision is made to transmit an eighth-rate frame, a smoothed prototype of the eighth-rate frame is  
 20 transmitted rather than the Rate 1/8 frame computed according to Section 4.15. The gains and the LSPs are  
 21 statistically smoothed in that, the smoothed prototype contains the gain and LSPs that have been most often  
 22 chosen in the recent past.

#### 23 4.18 Coding the High-Frequency Band Of Wideband Speech

##### 24 4.18.1 Declick Algorithm

25 The basic idea of the click-removing algorithm is to detect energy bursts that exist in the high band but not in  
 26 the low band, and then briefly reduce the level of the high-band signal during each of these energy bursts.

27

28 Figure 4.18.1-1 shows the algorithm. It operates on frames of 20 milliseconds, and the low-band is sampled at 8  
 29 KHz and the high-band is sampled at 7kHz. The low-band input is filtered with a shaping filter of the form

$$30 F_{LB}(z) = \frac{1 + 0.96z^{-1} + 0.96z^{-2} + z^{-3}}{1 - 0.5z^{-1}},$$

31 which removes very low and high frequencies from the low-band signal. The high band is filtered with a  
 32 shaping filter of the form

$$33 F_{HB}(z) = \frac{0.5 + z^{-1} + 0.5z^{-2}}{1 + 0.5z^{-1} + 0.3z^{-2}},$$

34 which removes frequencies around 4 kHz.

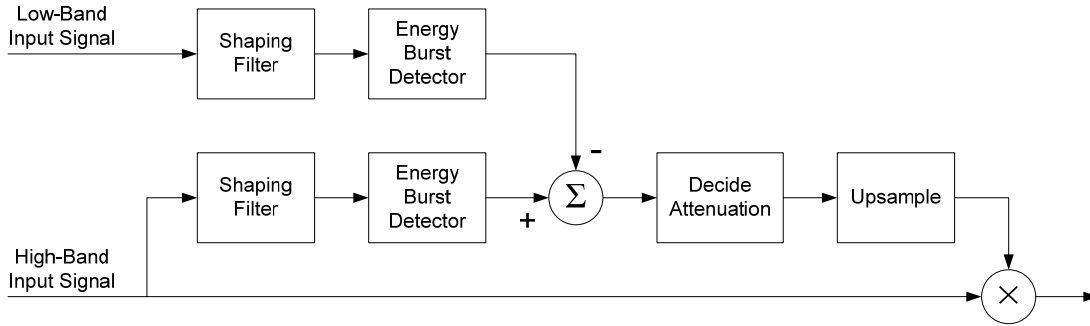

Figure 4.18.1-1 Pre-processing of the high band to remove clicks

In the next step, the shaped low band and high band are both processed by an energy burst detector, depicted in Figure 4.18.1-2. The energy burst detector combines a forward-moving and a backward-moving edge detector. The forward-moving edge detector first computes the square of each sample to obtain the energy signal. Then a smoothing operation is performed according to

$$S(n) = \begin{cases} P(n), & \text{if } P(n) \geq S(n-1) \\ \alpha S(n-1) + (1-\alpha)P(n), & \text{if } P(n) < S(n-1), \end{cases}$$

where  $P(n)$  is the energy signal,  $S(n)$  is the smoothed energy signal, and  $\alpha$  is a decay factor such that the decay time of the smoother is about 5 milliseconds. The smoothed energy signal is subsequently down-sampled to a 1 kHz sampling rate, and converted to a logarithmic scale. The resulting signal is reduced by a delayed version of itself, where the delay is about 4 milliseconds, to obtain the output of the forward-moving edge detector. The same procedure is followed to find the backward-moving edge detector signal, with the difference that all operations are reversed in time: processing starts a few milliseconds beyond the end of the current frame and progresses to the beginning of the current frame. Finally, we combine the two edge detectors by clipping the negative values ( $out = \max(in, 0)$ ) and taking the mean of these clipped signals. The arithmetic mean ( $\frac{1}{2}(a+b)$ ) is used by the energy burst detector operating on the low band, whereas the high band energy burst detector uses the more conservative geometric mean ( $\sqrt{a \cdot b}$ ). The output signal indicates the time location and strength of energy bursts in the input signal, on a logarithmic scale, and is always equal to or larger than zero.

Next, the outputs of the low-band and high-band energy burst detectors are combined by subtracting the former from the latter to produce a signal that indicates where energy bursts exist in the high band that do not occur (or are weaker) in the low band. This signal is used to decide how much to attenuate the high band using the formula

$$A_{dB} = \begin{cases} 0, & \text{if } D_{dB} < T_{dB} \\ 20 \left( 1 - \frac{2}{1 + \exp(D_{dB}/10)} \right), & \text{if } D_{dB} > T_{dB}, \end{cases}$$

where  $D_{dB}$  is the difference between high-band and low-band energy burst detectors,  $T_{dB}$  is a threshold above which energy bursts will be attenuated (we use 8 dB as the threshold), and  $A_{dB}$  is the attenuation that will be applied to the high-band signal. The attenuation signal, being derived from the energy burst detector outputs, is

1 sampled at 1 kHz, and is up-sampled to a sampling rate equal to that of the high band (7 kHz) using windowed  
 2 sinc functions. Finally, we multiply the high-band signal by the up-sampled attenuation signal to obtain the  
 3 click-removed high-band signal.

4

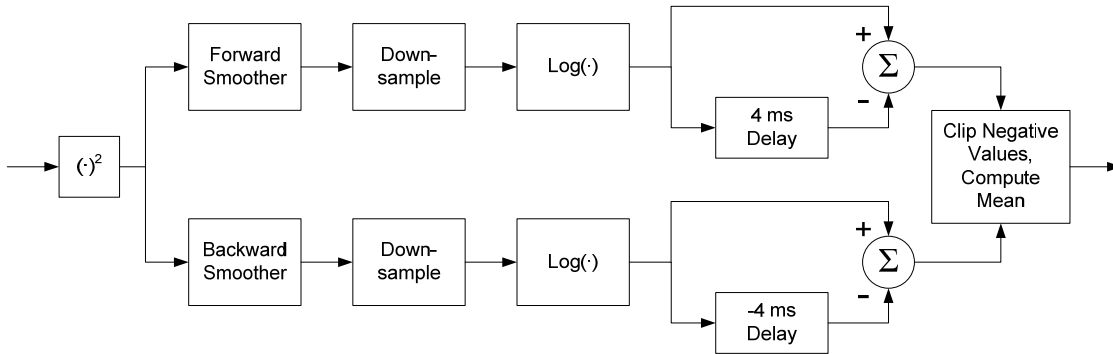

5

6

**Figure 4.18.1-2 Energy burst detector**

7 4.18.2 High-Band LPC Analysis and Quantization

8 Six spectral parameters are obtained by a traditional linear prediction (LPC) analysis. For efficient coding, these  
 9 prediction coefficients are converted to line spectral frequencies (LSFs) and quantized using a vector quantizer  
 10 using 8 bits.

11

12 The LSF quantizer is improved by incorporating temporal noise shaping.. For each frame, the LSF quantization  
 13 error vector is computed and multiplied by a scale factor less than 1.0. The following frame, this scaled  
 14 quantization error is added to the LSF vector before quantization. The scale factor is adjusted dynamically  
 15 depending on the amount of fluctuations already present in the unquantized LSF vectors: when the difference  
 16 between the current and previous LSF vectors is large, the scale factor is close to zero and almost no noise  
 17 shaping results. When the current LSF vector differs little from the previous one, the scale factor is close to 1.0.  
 18 The resulting LSF quantization minimizes spectral distortion when the speech signal is changing, and  
 19 minimizes spectral fluctuations when the speech signal is relatively constant from one frame to the next.

20 4.18.3 High-Band Excitation Generation

21 The high-band excitation signal is derived from the low-band excitation in the form of the excitation signal.

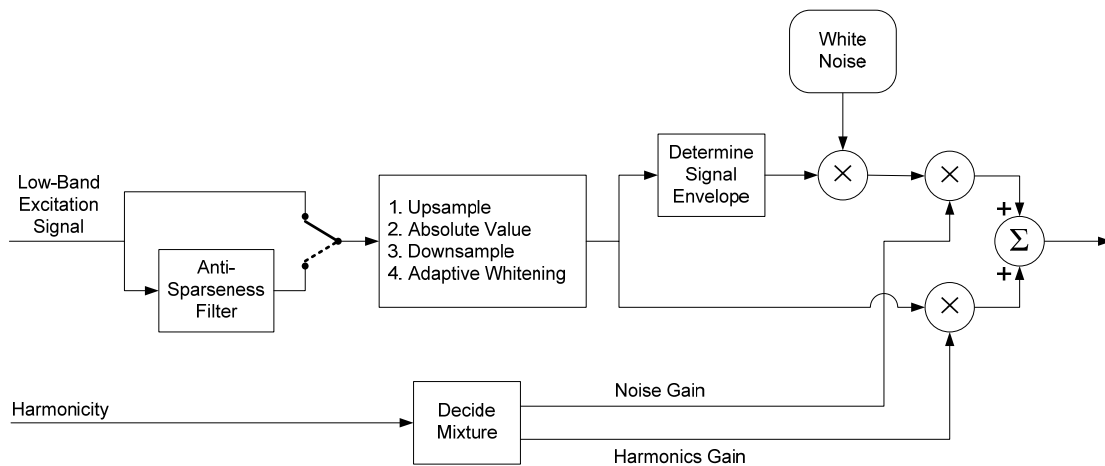

**Figure 4.18.3-1 Generation of the high-band excitation signal**

Figure 4.18.3-1 depicts the process that generates the high-band excitation from the narrowband excitation signal. The excitation signal is first run through an all-pass filter of the form

$$H(z) = \frac{-0.7 + z^{-4}}{1 - 0.7z^{-4}} \cdot \frac{0.6 + z^{-6}}{1 + 0.6z^{-6}}.$$

The decision to use the output of the filter or the original input signal is derived from the quantized narrowband adaptive codebook gain and first reflection coefficient: unvoiced signals are characterized by a low adaptive codebook gain and a first reflection coefficient that is close to zero or positive (indicating a flat or upwards-tilted spectrum).

Next is the nonlinear function. This module up-samples the signal to 16 kHz before applying the absolute value non-linear function. From here, a 8 kHz-sampled signal is produced using the same high-band analysis filter that was used to split the input signal in a low and a high band in Section 4.5. The result is spectrally flattened with an adaptive 4<sup>th</sup> order linear prediction filter, to create the harmonically-extended excitation signal.

A modulated noise signal is generated by multiplying a unit-variance white noise signal with the envelope of the harmonically-extended excitation signal. This envelope is obtained by taking the squared value of each sample, smoothing with a first order IIR low-pass filter and taking the square-root of each smoothed sample.

The modulated noise and harmonically-extended excitation signals are now mixed together to create a signal with the right amount of harmonic and noise contents. The gains of the noise and harmonics parts are set adaptively to match the ratio of harmonic to noise energy in the high band of the original speech signal. Typically, the noise gain is between 0.1 and 0.7, and the harmonics gain is derived from the noise gain as  $G_{harm} = \sqrt{1 - G_{noise}^2}$ , so that the energy of the output signal is not affected by changing the gains.

1 Note that the high-band excitation is generated in both encoder and decoder. The encoder determines the side  
 2 information for the gain factors by comparing the synthesized high band with the original high band, and the  
 3 decoder then uses these gains to properly scale the synthesized high band. For the decoding process to be  
 4 consistent with the encoding process, it is important that identical high-band excitations be generated in  
 5 encoder and decoder. This is achieved by (1) using the *quantized* narrowband excitation, which is available to  
 6 both encoder and decoder, and (2) having the same state for the random white noise generator in encoder and  
 7 decoder at all times.

#### 10 4.18.4 Computation and Quantization of gains for high-band excitation

11 Five temporal gain parameters each represent the scale factor of a 4 millisecond subframe. The gain parameters  
 12 are found by comparing the energies in each subframe of the input high-band signal with the unscaled,  
 13 spectrally shaped high-band excitation signal. For each frame, a frame-level gain is first computed. This gain is  
 14 then used to normalize the 5 subframe gains. The subframe gain parameters are also quantized with a vector  
 15 quantizer, and the quantization index is transmitted to the decoder.

16 For voiced speech, frame-level gain is quantized using 4 bits look-up table quantizer. The subframe gains are  
 17 vector quantized using 4 bits.

18 For unvoiced speech, frame-level gain is quantized using 7 bit scalar quantizer. The subframe gains are vector  
 19 quantized using a multistage VQ with 4 bits per stage.

### 21 4.19 Packet Formatting for SO 3

22 After encoding, the encoded speech packets shall be formatted as described in Table 4.19-1. For each  
 23 parameter, bit index 0 corresponds to the most significant bit. The packet buffer bit index 1 indicates the bit  
 24 position corresponding to the beginning of the packet buffer. Parameter notations are defined as follows:

- 25 • *LPCFLAG*: spectral change indicator,
- 26 • *LSPIDX(k)[j]*: the *j*-th bit of the *k*-th LSP codebook for the entire frame, (4 codebooks for Rate 1,  
 27 3 for Rate 1/2, and 2 for Rate 1/8).
- 28 • *DELAY[j]*: the *j*-th bit of the pitch delay estimate for the entire frame,
- 29 • *DDELAY[j]*: the *j*-th bit of the delay difference for the entire frame,
- 30 • *ACBGIDX(m')[j]*: the *j*-th bit of the adaptive codebook gain index for the *m'*-th subframe,
- 31 • *FCBSIDX(m',k)[j]*: the *j*-th bit of the *k*-th fixed codebook shape index for the *m'*-th subframe, (4  
 32 codebooks for Rate 1, 1 for Rate 1/2),
- 33 • *FCBGIDX(m')[j]*: the *j*-th bit of the fixed codebook gain index for the *m'*-th subframe,
- 34 • *FGIDX[j]*: the *j*-th bit of the frame energy gain

35 In the case where a Rate 1/8 packet with all bits set to '1' (null Traffic Channel data) is generated, *FGIDX*[0] is  
 36 set to zero.

1

Table 4.19-1 Packet Formats

Bit Index	Rate 1 Packet Bits	Rate 1/2 Packet Bits	Rate 1/8 Packet Bits
1	<i>LPCFLAG</i>	<i>LSPIDX(1)[0]</i>	<i>LSPIDX(1)[0]</i>
2	<i>LSPIDX(1)[0]</i>	<i>LSPIDX(1)[1]</i>	<i>LSPIDX(1)[1]</i>
3	<i>LSPIDX(1)[1]</i>	<i>LSPIDX(1)[2]</i>	<i>LSPIDX(1)[2]</i>
4	<i>LSPIDX(1)[2]</i>	<i>LSPIDX(1)[3]</i>	<i>LSPIDX(1)[3]</i>
5	<i>LSPIDX(1)[3]</i>	<i>LSPIDX(1)[4]</i>	<i>LSPIDX(2)[0]</i>
6	<i>LSPIDX(1)[4]</i>	<i>LSPIDX(1)[5]</i>	<i>LSPIDX(2)[1]</i>
7	<i>LSPIDX(1)[5]</i>	<i>LSPIDX(1)[6]</i>	<i>LSPIDX(2)[2]</i>
8	<i>LSPIDX(2)[0]</i>	<i>LSPIDX(2)[0]</i>	<i>LSPIDX(2)[3]</i>
9	<i>LSPIDX(2)[1]</i>	<i>LSPIDX(2)[1]</i>	<i>FGIDX[0]</i>
10	<i>LSPIDX(2)[2]</i>	<i>LSPIDX(2)[2]</i>	<i>FGIDX[1]</i>
11	<i>LSPIDX(2)[3]</i>	<i>LSPIDX(2)[3]</i>	<i>FGIDX[2]</i>
12	<i>LSPIDX(2)[4]</i>	<i>LSPIDX(2)[4]</i>	<i>FGIDX[3]</i>
13	<i>LSPIDX(2)[5]</i>	<i>LSPIDX(2)[5]</i>	<i>FGIDX[4]</i>
14	<i>LSPIDX(3)[0]</i>	<i>LSPIDX(2)[6]</i>	<i>FGIDX[5]</i>
15	<i>LSPIDX(3)[1]</i>	<i>LSPIDX(3)[0]</i>	<i>FGIDX[6]</i>
16	<i>LSPIDX(3)[2]</i>	<i>LSPIDX(3)[1]</i>	<i>FGIDX[7]</i>
17	<i>LSPIDX(3)[3]</i>	<i>LSPIDX(3)[2]</i>	
18	<i>LSPIDX(3)[4]</i>	<i>LSPIDX(3)[3]</i>	
19	<i>LSPIDX(3)[5]</i>	<i>LSPIDX(3)[4]</i>	
20	<i>LSPIDX(3)[6]</i>	<i>LSPIDX(3)[5]</i>	
21	<i>LSPIDX(3)[7]</i>	<i>LSPIDX(3)[6]</i>	
22	<i>LSPIDX(3)[8]</i>	<i>LSPIDX(3)[7]</i>	
23	<i>LSPIDX(4)[0]</i>	<i>DELAY[0]</i>	
24	<i>LSPIDX(4)[1]</i>	<i>DELAY[1]</i>	
25	<i>LSPIDX(4)[2]</i>	<i>DELAY[2]</i>	
26	<i>LSPIDX(4)[3]</i>	<i>DELAY[3]</i>	
27	<i>LSPIDX(4)[4]</i>	<i>DELAY[4]</i>	
28	<i>LSPIDX(4)[5]</i>	<i>DELAY[5]</i>	
29	<i>LSPIDX(4)[6]</i>	<i>DELAY[6]</i>	
30	<i>DELAY[0]</i>	<i>ACBGIDX(0)[0]</i>	
31	<i>DELAY[1]</i>	<i>ACBGIDX(0)[1]</i>	
32	<i>DELAY[2]</i>	<i>ACBGIDX(0)[2]</i>	
33	<i>DELAY[3]</i>	<i>FCBSIDX(0,0)[0]</i>	
34	<i>DELAY[4]</i>	<i>FCBSIDX(0,0)[1]</i>	
35	<i>DELAY[5]</i>	<i>FCBSIDX(0,0)[2]</i>	
36	<i>DELAY[6]</i>	<i>FCBSIDX(0,0)[3]</i>	
37	<i>DDELAY[0]</i>	<i>FCBSIDX(0,0)[4]</i>	
38	<i>DDELAY[1]</i>	<i>FCBSIDX(0,0)[5]</i>	
39	<i>DDELAY[2]</i>	<i>FCBSIDX(0,0)[6]</i>	
40	<i>DDELAY[3]</i>	<i>FCBSIDX(0,0)[7]</i>	
41	<i>DDELAY[4]</i>	<i>FCBSIDX(0,0)[8]</i>	
42	<i>ACBGIDX(0)[0]</i>	<i>FCBSIDX(0,0)[9]</i>	
43	<i>ACBGIDX(0)[1]</i>	<i>FCBGIDX(0)[0]</i>	
44	<i>ACBGIDX(0)[2]</i>	<i>FCBGIDX(0)[1]</i>	
45	<i>FCBSIDX(0,0)[0]</i>	<i>FCBGIDX(0)[2]</i>	
46	<i>FCBSIDX(0,0)[1]</i>	<i>FCBGIDX(0)[3]</i>	
47	<i>FCBSIDX(0,0)[2]</i>	<i>ACBGIDX(1)[0]</i>	
48	<i>FCBSIDX(0,0)[3]</i>	<i>ACBGIDX(1)[1]</i>	
49	<i>FCBSIDX(0,0)[4]</i>	<i>ACBGIDX(1)[2]</i>	
50	<i>FCBSIDX(0,0)[5]</i>	<i>FCBSIDX(1,0)[0]</i>	
51	<i>FCBSIDX(0,0)[6]</i>	<i>FCBSIDX(1,0)[1]</i>	

52	<i>FCBSIDX(0,0)[7]</i>	<i>FCBSIDX(1,0)[2]</i>	
53	<i>FCBSIDX(0,1)[0]</i>	<i>FCBSIDX(1,0)[3]</i>	
54	<i>FCBSIDX(0,1)[1]</i>	<i>FCBSIDX(1,0)[4]</i>	
55	<i>FCBSIDX(0,1)[2]</i>	<i>FCBSIDX(1,0)[5]</i>	
56	<i>FCBSIDX(0,1)[3]</i>	<i>FCBSIDX(1,0)[6]</i>	
57	<i>FCBSIDX(0,1)[4]</i>	<i>FCBSIDX(1,0)[7]</i>	
58	<i>FCBSIDX(0,1)[5]</i>	<i>FCBSIDX(1,0)[8]</i>	
59	<i>FCBSIDX(0,1)[6]</i>	<i>FCBSIDX(1,0)[9]</i>	
60	<i>FCBSIDX(0,1)[7]</i>	<i>FCBGIDX(1)[0]</i>	
61	<i>FCBSIDX(0,2)[0]</i>	<i>FCBGIDX(1)[1]</i>	
62	<i>FCBSIDX(0,2)[1]</i>	<i>FCBGIDX(1)[2]</i>	
63	<i>FCBSIDX(0,2)[2]</i>	<i>FCBGIDX(1)[3]</i>	
64	<i>FCBSIDX(0,2)[3]</i>	<i>ACBGIDX(2)[0]</i>	
65	<i>FCBSIDX(0,2)[4]</i>	<i>ACBGIDX(2)[1]</i>	
66	<i>FCBSIDX(0,2)[5]</i>	<i>ACBGIDX(2)[2]</i>	
67	<i>FCBSIDX(0,2)[6]</i>	<i>FCBSIDX(2,0)[0]</i>	
68	<i>FCBSIDX(0,2)[7]</i>	<i>FCBSIDX(2,0)[1]</i>	
69	<i>FCBSIDX(0,3)[0]</i>	<i>FCBSIDX(2,0)[2]</i>	
70	<i>FCBSIDX(0,3)[1]</i>	<i>FCBSIDX(2,0)[3]</i>	
71	<i>FCBSIDX(0,3)[2]</i>	<i>FCBSIDX(2,0)[4]</i>	
72	<i>FCBSIDX(0,3)[3]</i>	<i>FCBSIDX(2,0)[5]</i>	
73	<i>FCBSIDX(0,3)[4]</i>	<i>FCBSIDX(2,0)[6]</i>	
74	<i>FCBSIDX(0,3)[5]</i>	<i>FCBSIDX(2,0)[7]</i>	
75	<i>FCBSIDX(0,3)[6]</i>	<i>FCBSIDX(2,0)[8]</i>	
76	<i>FCBSIDX(0,3)[7]</i>	<i>FCBSIDX(2,0)[9]</i>	
77	<i>FCBSIDX(0,3)[8]</i>	<i>FCBGIDX(2)[0]</i>	
78	<i>FCBSIDX(0,3)[9]</i>	<i>FCBGIDX(2)[1]</i>	
79	<i>FCBSIDX(0,3)[10]</i>	<i>FCBGIDX(2)[2]</i>	
80	<i>FCBGIDX(0)[0]</i>	<i>FCBGIDX(2)[3]</i>	
81	<i>FCBGIDX(0)[1]</i>		
82	<i>FCBGIDX(0)[2]</i>		
83	<i>FCBGIDX(0)[3]</i>		
84	<i>FCBGIDX(0)[4]</i>		
85	<i>ACBGIDX(1)[0]</i>		
86	<i>ACBGIDX(1)[1]</i>		
87	<i>ACBGIDX(1)[2]</i>		
88	<i>FCBSIDX(1,0)[0]</i>		
89	<i>FCBSIDX(1,0)[1]</i>		
90	<i>FCBSIDX(1,0)[2]</i>		
91	<i>FCBSIDX(1,0)[3]</i>		
92	<i>FCBSIDX(1,0)[4]</i>		
93	<i>FCBSIDX(1,0)[5]</i>		
94	<i>FCBSIDX(1,0)[6]</i>		
95	<i>FCBSIDX(1,0)[7]</i>		
96	<i>FCBSIDX(1,1)[0]</i>		
97	<i>FCBSIDX(1,1)[1]</i>		
98	<i>FCBSIDX(1,1)[2]</i>		
99	<i>FCBSIDX(1,1)[3]</i>		
100	<i>FCBSIDX(1,1)[4]</i>		
101	<i>FCBSIDX(1,1)[5]</i>		
102	<i>FCBSIDX(1,1)[6]</i>		
103	<i>FCBSIDX(1,1)[7]</i>		
104	<i>FCBSIDX(1,2)[0]</i>		
105	<i>FCBSIDX(1,2)[1]</i>		

106	<i>FCBSIDX(1,2)[2]</i>		
107	<i>FCBSIDX(1,2)[3]</i>		
108	<i>FCBSIDX(1,2)[4]</i>		
109	<i>FCBSIDX(1,2)[5]</i>		
110	<i>FCBSIDX(1,2)[6]</i>		
111	<i>FCBSIDX(1,2)[7]</i>		
112	<i>FCBSIDX(1,3)[0]</i>		
113	<i>FCBSIDX(1,3)[1]</i>		
114	<i>FCBSIDX(1,3)[2]</i>		
115	<i>FCBSIDX(1,3)[3]</i>		
116	<i>FCBSIDX(1,3)[4]</i>		
117	<i>FCBSIDX(1,3)[5]</i>		
118	<i>FCBSIDX(1,3)[6]</i>		
119	<i>FCBSIDX(1,3)[7]</i>		
120	<i>FCBSIDX(1,3)[8]</i>		
121	<i>FCBSIDX(1,3)[9]</i>		
122	<i>FCBSIDX(1,3)[10]</i>		
123	<i>FCBGIDX(1)[0]</i>		
124	<i>FCBGIDX(1)[1]</i>		
125	<i>FCBGIDX(1)[2]</i>		
126	<i>FCBGIDX(1)[3]</i>		
127	<i>FCBGIDX(1)[4]</i>		
128	<i>ACBGIDX(2)[0]</i>		
129	<i>ACBGIDX(2)[1]</i>		
130	<i>ACBGIDX(2)[2]</i>		
131	<i>FCBSIDX(2,0)[0]</i>		
132	<i>FCBSIDX(2,0)[1]</i>		
133	<i>FCBSIDX(2,0)[2]</i>		
134	<i>FCBSIDX(2,0)[3]</i>		
135	<i>FCBSIDX(2,0)[4]</i>		
136	<i>FCBSIDX(2,0)[5]</i>		
137	<i>FCBSIDX(2,0)[6]</i>		
138	<i>FCBSIDX(2,0)[7]</i>		
139	<i>FCBSIDX(2,1)[0]</i>		
140	<i>FCBSIDX(2,1)[1]</i>		
141	<i>FCBSIDX(2,1)[2]</i>		
142	<i>FCBSIDX(2,1)[3]</i>		
143	<i>FCBSIDX(2,1)[4]</i>		
144	<i>FCBSIDX(2,1)[5]</i>		
145	<i>FCBSIDX(2,1)[6]</i>		
146	<i>FCBSIDX(2,1)[7]</i>		
147	<i>FCBSIDX(2,2)[0]</i>		
148	<i>FCBSIDX(2,2)[1]</i>		
149	<i>FCBSIDX(2,2)[2]</i>		
150	<i>FCBSIDX(2,2)[3]</i>		
151	<i>FCBSIDX(2,2)[4]</i>		
152	<i>FCBSIDX(2,2)[5]</i>		
153	<i>FCBSIDX(2,2)[6]</i>		
154	<i>FCBSIDX(2,2)[7]</i>		
155	<i>FCBSIDX(2,3)[0]</i>		
156	<i>FCBSIDX(2,3)[1]</i>		
157	<i>FCBSIDX(2,3)[2]</i>		
158	<i>FCBSIDX(2,3)[3]</i>		
159	<i>FCBSIDX(2,3)[4]</i>		

160	<i>FCBSIDX(2,3)[5]</i>		
161	<i>FCBSIDX(2,3)[6]</i>		
162	<i>FCBSIDX(2,3)[7]</i>		
163	<i>FCBSIDX(2,3)[8]</i>		
164	<i>FCBSIDX(2,3)[9]</i>		
165	<i>FCBSIDX(2,3)[10]</i>		
166	<i>FCBGIDX(2)[0]</i>		
167	<i>FCBGIDX(2)[1]</i>		
168	<i>FCBGIDX(2)[2]</i>		
169	<i>FCBGIDX(2)[3]</i>		
170	<i>FCBGIDX(2)[4]</i>		
171	TTY Baud Rate Bit		

1 **4.20 Packet Formatting for SO 68**

2 The parameters are packed MSB first. That is, in the notation, Ps-Pe used in "Bit index in Packet" column, Ps  
 3 refers to the MSB of the parameter, and Pe refers to the LSB of the parameter.

4 **Table 4.20-1 Packet formatting for Full-rate CELP**

Parameter (Value)	Number of Bits	Bit index in Packet
ModeBit (0)	1	P0-P0
DelayIndex	7	P1-P7
LSP_IDX0	6	P8-P13
LSP_IDX1	6	P14-P19
LSP_IDX2	9	P20-P28
LSP_IDX3	7	P29-P35
DDELAY_IDX	5	P36-P40
ACBG_IDX_SF0	3	P41-P43
ACBG_IDX_SF1	3	P44-P46
ACBG_IDX_SF2	3	P47-P49
FCB_PULSE_IDX0_SF 0	16	P50-P65
FCB_PULSE_IDX1_SF 0	16	P66-P81
FCB_PULSE_IDX2_SF 0	3	P82-P84
FCB_PULSE_IDX0_SF 1	16	P85-P100
FCB_PULSE_IDX1_SF 1	16	P101-P116
FCB_PULSE_IDX2_SF	3	P117-P119

1		
FCB_PULSE_IDX0_SF 2	16	P120-P135
FCB_PULSE_IDX1_SF 2	16	P136-P151
FCB_PULSE_IDX2_SF 2	3	P152-P154
FCBG_IDX_SF0	5	P155-P159
FCBG_IDX_SF1	5	P160-P164
FCBG_IDX_SF2	5	P165-P169
RESERVED (0)	1	P170

1

2

**Table 4.20-2 Packet formatting for Full-rate PPP**

<b>Parameter (Value)</b>	<b>Number of Bits</b>	<b>Bit index in Packet</b>
ModeBit (1)	1	P0-P0
DelayIndex	7	P1-P7
LSP_IDX0	6	P8-P13
LSP_IDX1	6	P14-P19
LSP_IDX2	9	P20-P28
LSP_IDX3	7	P29-P35
ROTATION_IDX	7	P36-P42
AMP_IDX0	6	P43-P48
AMP_IDX1	6	P49-P54
AMP_IDX2	8	P55-62
POWER_IDX	8	P63-70
ALIGN_IDX0	5	P71-P75
ALIGN_IDX1	5	P76-P80
ALIGN_IDX2	5	P81-P85
ALIGN_IDX3	6	P86-P91
ALIGN_IDX4	6	P92-P97
ALIGN_IDX5	6	P98-P103
ALIGN_IDX6	6	P104-P109
ALIGN_IDX7	6	P110-P115

ALIGN_IDX8	6	P116-P121
ALIGN_IDX9	6	P122-P127
ALIGN_IDX10	6	P128-P133
ALIGN_IDX11	6	P134-P139
ALIGN_IDX12	6	P140-P145
ALIGN_IDX13	6	P146-P151
ALIGN_IDX14	6	P152-P157
ALIGN_IDX15	6	P158-P163
ALIGN_IDX16	6	P164-P169
RESERVED (0)	1	P170

1

2

**Table 4.20-3 Packet formatting for Half-rate CELP**

<b>Parameter (Value)</b>	<b>Number of Bits</b>	<b>Bit index in Packet</b>
DelayIndex	7	P0-P6
LSP_IDX0	7	P7-P13
LSP_IDX1	7	P14-P20
LSP_IDX2	8	P21-P28
ACBG_IDX_SF0	3	P29-P31
ACBG_IDX_SF1	3	P32-P34
ACBG_IDX_SF2	3	P35-P37
FCB_PULSE_IDX0_SF 0	10	P38-P47
FCB_PULSE_IDX0_SF 1	10	P48-P57
FCB_PULSE_IDX0_SF 2	10	P58-P67
FCBG_IDX_SF0	4	P68-P71
FCBG_IDX_SF1	4	P72-P75
FCBG_IDX_SF2	4	P76-P79

3

4

**Table 4.20-4 Packet formatting for Special Half-rate CELP**

<b>Parameter (Value)</b>	<b>Number of Bits</b>	<b>Bit index in Packet</b>
--------------------------	-----------------------	----------------------------

SpecialHalfCelpFlag0(0x6E )	7	P0-P6
SpecialHalfCelpFlag1(0x00)	2	P7-P8
ModeBit (0)	1	P9-P9
LSP_IDX0	6	P10-P15
LSP_IDX1	6	P16-P21
LSP_IDX2	9	P22-P30
LSP_IDX3	7	P31-P37
ACBG_IDX_SF0	3	P38-P40
ACBG_IDX_SF1	3	P41-P43
ACBG_IDX_SF2	3	P44-P46
DelayIndex	7	P47-P53
RESERVED (all 0s)	26	P54-P79

1

2

**Table 4.20-5 Packet formatting for Special Half-rate PPP**

<b>Parameter (Value)</b>	<b>Number of Bits</b>	<b>Bit index in Packet</b>
SpecialHalfPPPFlag0(0x6E)	7	P0-P6
SpecialHalfPPPFlag1(0x00)	2	P7-P8
ModeBit (1)	1	P9-P9
LSP_IDX0	6	P10-P15
LSP_IDX1	6	P16-P21
LSP_IDX2	9	P22-P30
LSP_IDX3	7	P31-P37
ROTATION_IDX	7	P38-P44
AMP_IDX0	6	P45-P50
AMP_IDX1	6	P51-P56
AMP_IDX2	8	P57-64
POWER_IDX	8	P65-72
DelayIndex	7	P73-P79

1

2

**Table 4.20-6 Packet formatting for Special Half-rate NELP**

<b>Parameter (Value)</b>	<b>Number of Bits</b>	<b>Bit index in Packet</b>
SpecialHalfNelpFlag0(0x6E)	7	P0-P6
SpecialHalfNelpFlag1(0x01)	2	P7-P8
LSP_IDX0	8	P9-P16
LSP_IDX1	8	P17-P24
NELP_GAIN_IDX0	5	P25-P29
NELP_GAIN_IDX1	6	P30-P35
NELP_GAIN_IDX2	6	P36-P41
NELP_FILTER_ID	2	P42-P43
RESERVED (all 0s)	36	P44-P79

3

4

**Table 4.20-7 Packet formatting for Quarter-rate NELP**

<b>Parameter (Value)</b>	<b>Number of Bits</b>	<b>Bit index in Packet</b>
ModeBit (0)	1	P0-P0
LSP_IDX0	8	P1-P8
LSP_IDX1	8	P9-P16
NELP_GAIN_IDX0	5	P17-P21
NELP_GAIN_IDX1	6	P22-P27
NELP_GAIN_IDX2	6	P28-P33
NELP_FILTER_ID	2	P34-P35
RESERVED (0)	4	P36-P39

5

6

**Table 4.20-8 Packet formatting for Quarter-rate PPP**

<b>Parameter (Value)</b>	<b>Number of Bits</b>	<b>Bit index in Packet</b>
ModeBit (1)	1	P0-P0
LSP_IDX0	10	P1-P10
LSP_IDX1	6	P11-P16
DELTA LAG_IDX	4	P17-P20

AMP_IDX0	6	P21-P26
AMP_IDX1	6	P27-P32
POWER_IDX	6	P33-P38
RESERVED (0)	1	P39-P39

1

2

**Table 4.20-9 Packet formatting for Eighth-Rate**

Parameter (Value)	Number of Bits	Bit index in Packet
LSP_IDX0	4	P1-P4
LSP_IDX1	4	P5-P8
GAIN_IDX	6	P9-P14
RESERVED0 (0)	1	P15-P15
RESERVED1 (0)	1	P16-P16
POWER_IDX	6	P33-P38
RESERVED (0)	1	P39-P39

3

#### 4.20.1 Special Half NELP frame

This frame format carries the NELP frame in a half-rate packet. This packet is used in half-rate max mode.

#### 4.20.2 Packet Level Signaling Interworking Function

Table 4.20-4 and Table 4.20-5 show special half-rate CELP and special half-rate PPP frames formats.

A packet level signaling interworking function that needs to dim a full-rate packet CELP packet to a special half-rate CELP packet should receive a packet in the frame in the format described in Table 4.20-1 and convert it to the format described in Table 4.20-4 by relocating some of the parameters (those that are common between Table 4.20-1 and Table 4.20-4) and setting the SpecialHalfRateCELP flag.

A packet level signaling interworking function that needs to dim a full-rate packet PPP packet to a special half-rate PPP packet should receive a packet in the frame in the format described in Table 4.20-2 and convert it to the format described in Table 4.20-5 by relocating some of the parameters (those that are common between Table 4.20-2 and Table 4.20-5) and setting the SpecialHalfRateCELP flag.

### 4.21 Packet Formatting for SO 70

The parameters are packed MSB first. That is, in the notation, Ps-Pe used in "Bit index in Packet" column, Ps refers to the MSB of the parameter, and Pe refers to the LSB of the parameter.

19

Table 4.21-1 Packet formatting for Full-rate CELP in SO 68 Interoperable Mode

Parameter (Value)	Number of Bits	Bit index in Packet
ModeBit (0)	1	P0-P0
DelayIndex	7	P1-P7
LSP_IDX0	6	P8-P13
LSP_IDX1	6	P14-P19
LSP_IDX2	9	P20-P28
LSP_IDX3	7	P29-P35
DDELAY_IDX	5	P36-P40
ACBG_IDX_SF0	3	P41-P43
ACBG_IDX_SF1	3	P44-P46
ACBG_IDX_SF2	3	P47-P49
FCB_PULSE_IDX0_SF 0	16	P50-P65
FCB_PULSE_IDX1_SF 0	16	P66-P81
FCB_PULSE_IDX2_SF 0	3	P82-P84
FCB_PULSE_IDX0_SF 1	16	P85-P100
FCB_PULSE_IDX1_SF 1	16	P101-P116
FCB_PULSE_IDX2_SF 1	3	P117-P119
FCB_PULSE_IDX0_SF 2	16	P120-P135
FCB_PULSE_IDX1_SF 2	16	P136-P151
FCB_PULSE_IDX2_SF 2	3	P152-P154
FCBG_IDX_SF0	5	P155-P159
FCBG_IDX_SF1	5	P160-P164
FCBG_IDX_SF2	5	P165-P169
EVRCB_IO_FLAG (0)	1	P170

1

2

**Table 4.21-2 Packet formatting for Full-rate Wideband CELP Frame**

<b>Parameter (Value)</b>	<b>Number of Bits</b>	<b>Bit index in Packet</b>
DelayIndex	7	P0-P6
LSP_IDX0	6	P7-P12
LSP_IDX1	6	P13-P18
LSP_IDX2	9	P19-P27
LSP_IDX3	7	P28-P34
ACBG_IDX_SF0	3	P35-P37
ACBG_IDX_SF1	3	P38-P40
ACBG_IDX_SF2	3	P41-P43
FCB_PULSE_IDX_DELAY_ADJUST	94	P44-P137
FCBG_IDX_SF0	5	P138-P142
FCBG_IDX_SF1	5	P143-P147
FCBG_IDX_SF2	5	P148-P152
HIGHBAND LSP_IDX	8	P153-P160
HIGHBAND_GAIN_SHAPE_IDX	4	P161-P164
HIGHBAND_GAIN_FRAME_IDX	4	P165-P168
MODEBIT (CELP/ MDCT) (0)	1	P169
EVRCB_IO_FLAG (1)	1	P170

3

4

**Table 4.21-3 Packet formatting for Full-rate Wideband MDCT Frame**

<b>Parameter (Value)</b>	<b>Number of Bits</b>	<b>Bit index in Packet</b>
LSP_IDX	28	P0-P27
MDCT_INDEX	114	P28-P141
FRAME_GAIN_INDEX	7	P142-P148
NOISE_GAIN_INDEX	2	P149-P150
HIGHBAND LSP_IDX	8	P151-P158
HIGHBAND_GAIN_SHAPE_IDX	4	P159-P162
HIGHBAND_GAIN_FRAME_IDX	4	P163-P166
RESERVED	1	167

NB_WB_MODE_BIT (1)	1	P168
MODEBIT (CELP/ MDCT/) (1)	1	P169
EVR_CB_IO_FLAG (1)	1	P170

1  
2

**Table 4.21-4 Packet formatting for Full-rate Narrowband MDCT Frame**

Parameter (Value)	Number of Bits	Bit index in Packet
LSP_IDX	28	P0-P27
MDCT_INDEX	131	P28-P158
FRAME_GAIN_INDEX	7	P159-P165
NOISE_GAIN_INDEX	2	P166-P167
NB_WB_MODE_BIT (0)	1	P168
MODEBIT (CELP/ MDCT) (1)	1	P169
EVR_CB_IO_FLAG (1)	1	P170

3  
4

**Table 4.21-5 Packet formatting for Half-rate Wideband NELP Frame**

Parameter (Value)	Number of Bits	Bit index in Packet
WB_HALFRATE_IDENTIFIER (0x3F)	6	P0-P5
LSP_IDX	28	P6-P33
NELP_GAIN_INDEX	17	P34-P50
NELP_FILTER_ID	2	P51-P52
HIGHBAND_LSP_IDX	12	P53-P64
HIGHBAND_GAIN_SHAPE_IDX	8	P65-P72
HIGHBAND_GAIN_FRAME_IDX	7	P73-P79

5  
6

**Table 4.21-6 Packet formatting for Half-rate CELP in SO 68 Interoperable Mode**

Parameter (Value)	Number of Bits	Bit index in Packet
DelayIndex	7	P0-P6
LSP_IDX0	7	P7-P13
LSP_IDX1	7	P14-P20
LSP_IDX2	8	P21-P28

ACBG_IDX_SF0	3	P29-P31
ACBG_IDX_SF1	3	P32-P34
ACBG_IDX_SF2	3	P35-P37
FCB_PULSE_IDX0_SF0	10	P38-P47
FCB_PULSE_IDX0_SF1	10	P48-P57
FCB_PULSE_IDX0_SF2	10	P58-P67
FCBG_IDX_SF0	4	P68-P71
FCBG_IDX_SF1	4	P72-P75
FCBG_IDX_SF2	4	P76-P79

1

2

3

**Table 4.21-7 Packet formatting for Eighth-Rate in SO 68 Interoperable Mode**

Parameter (Value)	Number of Bits	Bit index in Packet
LSP_IDX0	4	P0-P3
LSP_IDX1	4	P4-P7
GAIN_IDX	6	P8-P13
RESERVED0 (0)	1	P14-P14
RESERVED1 (0)	1	P15-P15

4

**Table 4.21-8 Packet formatting for Eighth-Rate in Wideband Mode**

Parameter (Value)	Number of Bits	Bit index in Packet
LSP_IDX	10	P0-P9
GAIN_IDX	5	P10-P14
WIDEBAND_FLAG (1)	1	P15-P15

5

6

**Table 4.21-9 Packet formatting for Special Half-rate Wideband CELP Frame (for packet level signaling)**

Parameter (Value)	Number of Bits	Bit index in Packet
SpecialHalfCelpFlag0(0x7B)	7	P0-P6
LSP_IDX	28	P7-P34

ACBG_IDX_SF0	3	P35-P37
ACBG_IDX_SF1	3	P38-P40
ACBG_IDX_SF2	3	P41-P43
DelayIndex	7	P44-P50
EVRCWB_SPL_HALF_MODE (0x00)	2	P51-P52
RESERVED (all 0s)	27	P53-P79

1  
2  
3  
4

**Table 4.21-10 Packet formatting for Special Half-rate CELP in SO 68 interoperable mode**

Parameter (Value)	Number of Bits	Bit index in Packet
SpecialHalfCelpFlag0(0x6E)	7	P0-P6
SpecialHalfCelpFlag1(0x00)	2	P7-P8
ModeBit (0)	1	P9-P9
LSP_IDX0	6	P10-P15
LSP_IDX1	6	P16-P21
LSP_IDX2	9	P22-P30
LSP_IDX3	7	P31-P37
ACBG_IDX_SF0	3	P38-P40
ACBG_IDX_SF1	3	P41-P43
ACBG_IDX_SF2	3	P44-P46
DelayIndex	7	P47-P53
RESERVED (all 0s)	26	P54-P79

5  
6  
7  
8  
9  
10  
11

4.21.1 Packet Level Signaling Interworking Function

A packet level signaling interworking function that needs to dim a wideband full-rate packet CELP packet to a special half-rate CELP packet should receive a packet in the frame in the format described in Table 4.21-2 and convert it to the format described in Table 4.21-9 by relocating some of the parameters (those that are common between Table 4.21-2 and Table 4.21-9) and setting the SpecialHalfRateCELP flag. The highband parameters are dropped and the decoder handles the highband part as in Frame Erasure processing.

- 1 A packet level signaling interworking function that needs to dim a EVRC-B interoperable full-rate packet
- 2 CELP packet to a EVRC-B interoperable special half-rate CELP packet should receive a packet in the frame in
- 3 the format described in Table 4.21-1 and convert it to the format described in Table 4.21-10 by relocating some
- 4 of the parameters (those that are common between the two tables) and setting the SpecialHalfRateCELP flag.



## 5 SPEECH DECODER

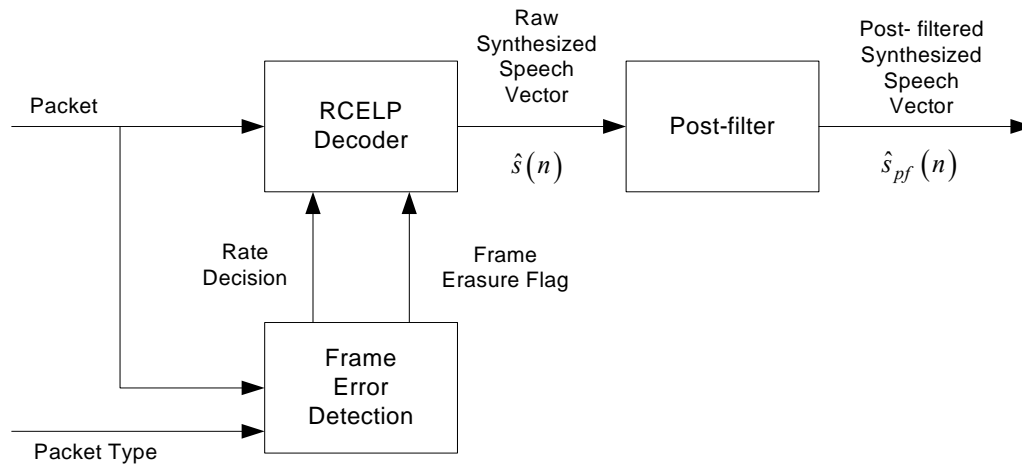

Figure 5-1 SO 3 Speech Decoder Top-Level Diagram

Figure 5-1 presents a top-level view of the EVRC speech decoder for SO 3. A top-level view of the EVRC-B speech decoder for SO 68 is presented in Figure 4.2-2. A top-level view of the EVRC-WB speech decoder for SO 70 is presented in Figure 4.3-3. The inputs to the decoder are the received speech packet, and a packet type indicator from the multiplex sub-layer. The frame error detection module uses the packet type indicator to determine the data rate and whether or not there was a frame error detected by the multiplex sub-layer. The decoder also applies rules to detect some channel errors not detected by the multiplex sub-layer.

The decoder uses the parameters contained in the received packet to re-synthesize the speech frame based on the rate decision. It uses the frame erasure flag to trigger frame error recovery logic. The raw synthesized speech is then post-filtered and output.

### 5.1 Frame Error Detection

**Inputs:** The inputs to frame error detection are:

The packet type supplied by the multiplex sublayer

- The delay transmission code, *DELAY*

**Outputs:** The outputs of frame error detection are:

- The frame erasure flag, *FER\_FLAG(m)*
- The rate of operation for the decoder, *Rate*

**Processing:** The frame error detector shall comprise 5.1.1 through 5.1.5.

**Initialization:**

- The last valid rate of operation, *last\_valid\_rate*, is initialized to Rate 1/8

- The frame erasure flag,  $FER\_FLAG(m) = FALSE$  ;  $m = 0$

5.1.1 Received Packet Type Processing for SO 3

The received packet type from the multiplex sublayer (see 2.1.2) is used to generate the decoder rate of operation,  $Rate$ , as well as the frame erasure flag,  $FER\_FLAG(m)$ .  $FER\_FLAG(m)$ , is defined for each received packet type in Table 5.1.1-1.

**Table 5.1.1-1 Received Packet Type Decoding**

Packet Type	$FER\_FLAG(m)$
Rate 1	FALSE
Rate 1/2	FALSE
Rate 1/4	TRUE
Rate 1/8	FALSE
Blank	TRUE
Insufficient frame quality (erasure)	TRUE
Rate 1/8 with all bits set to '1'	TRUE
Rate 1 with all bits set to '0'	TRUE
Rate 1/2 with all bits set to '0'	TRUE
Rate 1/4 with all bits set to '0'	TRUE
Rate 1/8 with all bits set to '0'	TRUE

The decoder rate of operation for the current frame,  $Rate$ , is then defined by the pseudo-code:

```

if (  $FER\_FLAG(m) == TRUE$  ) {
    if (  $last\_valid\_rate == Rate\ 1/8$  ) {
         $Rate = Rate\ 1/8$ 
    }
    else {
         $Rate = Rate\ 1$ 
    }
}

if ( ( $Rate == Rate\ 1/8$ ) and ( $last\_valid\_rate == Rate\ 1$ ) and
      ( $FER\_FLAG(m-1) == FALSE$ ) ) {
     $FER\_FLAG(m) = TRUE$ 
     $Rate = Rate\ 1$ 
}

if (  $FER\_FLAG(m) == FALSE$  ) {
     $Rate = Rate$  from received packet type
}

```

```

1         last_valid_rate = Rate
2     }

```

### 3 5.1.2 Received Packet Type Processing for SO 68

4 The received packet type from the multiplex sublayer (see 2.1.2) is used to generate the decoder rate of  
5 operation, *Rate*, as well as the frame erasure flag, *FER\_FLAG(m)*. *FER\_FLAG(m)*, is defined for each received  
6 packet type in Table 5.1.2-1.

7

8

**Table 5.1.2-1 Received Packet Type Decoding**

Packet Type	<i>FER_FLAG(m)</i>
Rate 1	FALSE
Rate 1/2	FALSE
Rate 1/4	FALSE
Rate 1/8	FALSE
Blank with last valid received rate not equal to Rate 1/8	TRUE
Blank with last valid received rate Rate 1/8	FALSE
Insufficient frame quality (erasure)	TRUE
Rate 1/8 with all bits set to '1'	TRUE
Rate 1 with all bits set to '0'	TRUE
Rate 1/2 with all bits set to '0'	TRUE
Rate 1/4 with all bits set to '0'	TRUE
Rate 1/8 with all bits set to '0'	TRUE

9

10 The decoder rate of operation for the current frame, *Rate*, is then defined by the pseudo-code:

```

11     if ( FER_FLAG(m) == TRUE ) {
12         if ( last_valid_rate == Rate 1/8 ) {
13             Rate = Rate 1/8
14         }
15         else {
16             Rate = Rate 1
17         }
18     }
19
20     if ( (Rate == Rate 1/8) and (last_valid_rate == Rate 1) and
21         (FER_FLAG(m-1) == FALSE) ) {
22         FER_FLAG(m) = TRUE
23         Rate = Rate 1
24     }

```

```

1         if ( FER_FLAG(m) == FALSE ) {
2             if (Rate == Blank) {
3
4                 Rate = last_valid_rate (also same as Rate 1/8)
5             }
6             else {
7                 Rate = Rate from received packet type
8                 last_valid_rate = Rate
9             }
10        }

```

### 11 5.1.3 Received Packet Type Processing for SO 70 (in WB mode)

12 Service Option 70 (in WB mode) treats received packets similar to service option 68 as described in Section  
13 5.1.2, with the exception of insufficient frame quality frames (erasures). Erasures are first checked to  
14 determine if they are suppressed eighth rate frames produced by DTX.

15 Before the decoder rate of operation for the current frame, *Rate*, is determined by the pseudo-code in Section  
16 5.1.2, the following pseudo-code examines erasure frames for possible suppressed eighth rate frames:

```

17         if ( Rate == Erasure ) {
18             if ((last_valid_rate == Rate 1/8) or (dtx_likely_flag == TRUE)) {
19                 Rate = Suppressed Rate 1/8
20             }
21        }

```

### 22 5.1.4 Packet Sanitycheck for Badrate Detection for SO 3

#### 23 5.1.4.1 Delay Parameter Checking

24 If *Rate* is determined to be Rate 1/2 or 1, and the delay transmission code, *DELAY*, is greater than 100, the  
25 *FER\_FLAG(m)* flag shall be set to TRUE.

#### 26 5.1.4.2 Delta Delay Parameter Checking

27 If *Rate* is determined to be Rate 1, the delta delay transmission code, *DDELAY*, shall be sanity checked. The  
28 last frame's delay shall be computed according to Equation 5.2.2-5. If the computed delay is less than *DMIN*  
29 or greater than *DMAX*, then the *FER\_FLAG(m)* flag shall be set to TRUE.

### 30 5.1.5 Packet Sanitycheck for Badrate Detection for SO 68

#### 31 5.1.5.1 Delay parameter checking

32 If *Rate* is determined to be Rate 1/2 or 1, and the delay transmission code, *DELAY*, is greater than 100, and not  
33 equal to 120 or 115, the *FER\_FLAG(m)* flag shall be set to TRUE.

1 5.1.5.2 Delta delay parameter checking

2 If Rate is determined to be Rate 1, the delta delay transmission code, DDELAY, shall be sanity checked. The  
3 last frame's delay shall be computed according to Equation 5.2.2-5. If the computed delay is less than DMIN or  
4 greater than DMAX, then the FER\_FLAG(m) flag shall be set to TRUE.

5 5.1.5.3 LSP checking

6 If Rate is determined to be Rate 1/2, decode the LSP parameters,  $\Omega_q(m)$ , as defined in Section 4.10, using the  
7 decoded LSP indices, LSPIDX(k). If  $\text{MAX}(\Omega_q(0), \Omega_q(1), \Omega_q(2)) \geq \text{MIN}(\Omega_q(6), \Omega_q(7), \Omega_q(8), \Omega_q(9))$ , the  
8 FER\_FLAG (m) flag shall be set to TRUE.

9 If Rate is determined to be Rate 1, decode the LSP parameters,  $\Omega_q(m)$ , as defined in Section 4.10, using the  
10 decoded LSP indices, LSPIDX(k). If  $\text{MAX}(\Omega_q(0), \Omega_q(1)) > \text{MIN}(\Omega_q(4), \Omega_q(5), \Omega_q(6))$ , the FER\_FLAG (m)  
11 flag shall be set to TRUE.

12 5.1.5.4 Unused bit checking

13 If Rate is determined to be Rate 1/8, and bit 15 of the received packet is 1, the FER\_FLAG (m) flag shall be set  
14 to TRUE.

15 If Rate is determined to be Rate 1/4 and frame is a NELP frame, and if any of the bits 36, 37, 38, 39 of the  
16 received packet is 1, the FER\_FLAG (m) flag shall be set to TRUE.

17 If Rate is determined to be Rate 1/4 and frame is a PPP frame, and if bit 39 of the received packet is 1, the  
18 FER\_FLAG (m) flag shall be set to TRUE.

19 5.1.5.5 Invalid filter ID

20 If Rate is determined to be Rate 1/4 and frame is a NELP frame, and the shaping filter ID is equal to 3, the  
21 FER\_FLAG (m) flag shall be set to TRUE.

22 5.1.5.6 Invalid transition

23 If Rate is determined to be Rate 1/4 and the frame is a PPP frame, and if the previous frame is a Rate 1/8, or a  
24 Rate 1/4 NELP frame, the FER\_FLAG (m) flag shall be set to TRUE.

25 If Rate is determined to be Rate 1 and the frame is a PPP frame, and if the previous frame is a Rate 1/8, or a  
26 Rate 1/4 NELP frame, the FER\_FLAG (m) flag shall be set to TRUE.

27

28

29 **5.2 Rate 1/2 and 1 CELP Decoding for SO 3, SO 68, and SO 70**

30 **Inputs:** The inputs to Rate 1/2 and 1 CELP decoding are:

- 31 • The quantized LSP indices from the current frame,  $LSPIDX(k)$
- 32 • The quantized LSPs from the previous frame,  $\Omega_q(m-1)$
- 33 • The adaptive codebook gain index,  $ACBGIDX(m')$ , for each subframe,  $m'$ ,
- 34 • The fixed codebook shape indices,  $FCBSIDX(m', k)$ , for each subframe,  $m'$ ,
- 35 • The fixed codebook gain indices,  $FCBGIDX(m', k)$ , for each subframe,  $m'$ ,

- 1 • The delay transmission code, *DELAY*
- 2 • The spectral transition indicator, *LPCFLAG*, Rate 1 only
- 3 • The delay difference, *DDELAY*, Rate 1 only
- 4 • The frame erasure flag, *FER\_FLAG(m)*, for the current frame, *m*

5 **Outputs:** The outputs from Rate 1/2 and 1 CELP decoding are:

- 6 • The post-filtered synthesized speech signal,  $\hat{s}_{pf}(n)$

7 **State Variables:**

- 8 • The adaptive codebook excitation,  $E(n)$

9 **Initialization:**

- 10 • The adaptive codebook excitation memory,  $E(n) = 0$ ;  $-128 \leq n < 64$
- 11 • The memory for the last valid adaptive codebook buffer,  $\{E_{by}(n)\} = 0$ ;  $0 \leq n < 128$
- 12 • The delay,  $\tau(m) = 40$ ;  $m = 0$
- 13 • The quantized LSPs,  $\Omega_q(m,k) = 0.048k$ ;  $1 \leq k \leq 10, m = 0$
- 14 • The codebook and pitch gains for the last valid frame (see 5.2.3.5 and 5.2.3.6)  
15  $g_c(m') = g_p(m') = 0$ ;  $0 \leq m' \leq 2$
- 16 • The fader scaler variable,  $\alpha_f = 1$

17 **Processing:**

18 Rate 1/2 and 1 decoding shall comprise 5.2.1 to 5.2.3

### 19 5.2.1 Decoding of the LSP Parameters

20 If (*FER\_FLAG(m) = TRUE*), use the LSP parameters from the last frame to generate bandwidth expanded LSPs  
21 for the current frame as follows:  $\Omega_q(m) = 0.875 \Omega_q(m-1) + 0.125 \Omega_{spread}$  where  $\Omega_{spread}$  are the initial values of  
22 the LSPs, as defined in Section 5.2.

23 Otherwise, decode the LSP parameters,  $\Omega_q(m)$ , as defined in 4.9.5, using the decoded LSP indices, *LSPIDX(k)*.  
24 In the event that the decoded LSPs are not strictly ascending, *FER\_FLAG(m)* shall be set to *TRUE*, where  
25 “strictly ascending” is defined as  $\Omega_q(m, i) < \Omega_q(m, i+1)$ ;  $1 \leq i \leq 9$ .

### 26 5.2.2 Delay Decoding and Frame Erasure Delay Contour Reconstruction

#### 27 5.2.2.1 Delay Decoding

28 The delay parameter,  $\tau(m)$ , for the current frame is defined as:

$$29 \tau(m) = \begin{cases} \tau(m-1) & ; FER\_FLAG(m) = TRUE, \\ DELAY + 20 & ; otherwise, \end{cases} \quad (5.2.2-1)$$

30 where *DELAY* is the pitch delay transmission code.

## 1 5.2.2.2 Frame Erasure Delay Contour Reconstruction for Rate 1 for SO 3

2 If ( $FER\_FLAG(m) = FALSE$ ) and ( $FER\_FLAG(m-1) = TRUE$ ) and ( $Rate = Rate 1$ ), the delay contour shall be  
 3 reconstructed (for Rate 1 operation only) by warping the last valid adaptive codebook memory buffer,  $E_{lv}(n)$ ,  
 4 using a recovered delay contour.  $E_{lv}(n)$  is first copied to the current adaptive codebook excitation memory,  
 5  $E(n)$ :

$$6 \quad E(n-128) = E_{lv}(n); \quad 0 \leq n < 128 \quad (5.2.2-2)$$

7 where  $E_{lv}(n)$  was determined in 5.2.3.9 for the last valid frame, and  $E(n)$  is the adaptive codebook excitation  
 8 memory.

9 5.2.2.3 Frame erasure delay contour reconstruction for Rate 1 good frame following an Erased Frame for SO  
 10 68

11 If ( $FER\_FLAG(m) = FALSE$ ) and ( $FER\_FLAG(m-1) = TRUE$ ) and ( $Rate = Rate 1$ ) and if the previous frame  
 12 was neither Silence nor Rate 1/4 NELP, the delay contour shall be reconstructed (for Rate 1 operation only) by  
 13 warping the last valid adaptive codebook memory buffer,  $E_{lv}(n)$ , using a recovered delay contour.  $E_{lv}(n)$  is first  
 14 copied to the current adaptive codebook excitation memory,  $E(n)$ :

$$15 \quad E(n-128) = E_{lv}(n); \quad 0 \leq n < 128 \quad (5.2.2-3)$$

16 where  $E_{lv}(n)$  was determined in Section 5.2.3.10 for the last valid frame, and  $E(n)$  is the adaptive codebook  
 17 excitation memory.

18

## 19 5.2.2.3.1 Delay Reconstruction

20 Calculate a delay,  $\tau'$ , which corresponds to the delay of the last valid frame:

$$21 \quad \tau' = \tau(m-1), \quad (5.2.2-4)$$

22 and recover the last frame's delay as computed in the encoder by using the delay difference:

$$23 \quad \tau(m-1) = \tau(m) - DDELAY - 16, \quad (5.2.2-5)$$

24 where  $DDELAY$  is the received delay difference transmission code, and  $\tau(m)$  is the current frame delay  
 25 parameter.

26 Limit  $\tau'$  by:

$$27 \quad \tau' = \begin{cases} \tau(m-1) & ; |\tau(m-1) - \tau'| > 15, \\ \tau' & ; otherwise, \end{cases} \quad (5.2.2-6.)$$

28  $E(n)$  is then warped using  $\tau'$  and  $\tau(m-1)$  in 5.2.2.3.2 and 5.2.2.3.3 for each subframe  $0 \leq m' < 3$ .

1 5.2.2.3.2 Reconstruction of the Delay Contour

2 The reconstructed delay contour,  $\tau_c(n)$ , is generated as defined in 4.11.5.1 of the encoder, using a set of delay  
3 interpolations computed by:

$$4 \quad \dot{d}^{(m', j)} = \begin{cases} \tau(m-1) & ; | \tau(m-1) - \tau' | > 15, \\ (1-f(m'+j))\tau(m-1) + f(m'+j)\tau' & ; otherwise, \end{cases} \quad 0 \leq j < 3, \quad (5.2.2-7)$$

6 where  $m$  is the current frame,  $m'$  is the subframe index, and  $m'+j$  is an index into an array of interpolator  
7 coefficients,  $f$ , defined by:

$$8 \quad f = \{ 0.0, 0.3313, 0.6625, 1.0, 1.0 \}. \quad (5.2.2-8)$$

9 5.2.2.3.3 Warping of the Adaptive Codebook Memory

10 The adaptive codebook memory,  $E(n)$ , is then mapped to the delay contour,  $\tau_c(n)$ , as described in 4.11.5.2 of  
11 the encoder.

12 5.2.2.4 Frame erasure delay contour reconstruction for Rate 1 good frame following a QPPP frame which  
13 follows an Erased Frame in SO 68  
14

15 If (FER\_FLAG(m) = FALSE) and (FER\_FLAG(m-1) = FALSE) and (FER\_FLAG(m-2) = TRUE) and (Rate =  
16 Rate 1) and if the previous frame was QPPP, the delay contour shall be reconstructed (for Rate 1 operation  
17 only) by warping the valid prior to the last valid adaptive codebook memory buffer,  $E_{lv}(n)$ , using a recovered  
18 delay contour.  $E_{lv}(n)$  is first copied to the current adaptive codebook excitation memory,  $E(n)$ :

$$19 \quad E(n-128) = E_{lv}(n); \quad 0 \leq n < 128 \quad (5.2.2-9)$$

20 where  $E_{lv}(n)$  was determined in Section 5.2.3.10 for the last valid frame, and  $E(n)$  is the adaptive codebook  
21 excitation memory.

22 5.2.2.4.1 Delay reconstruction

23 Recover the prior to the last frame's delay as computed in the encoder by using the delay difference:

$$24 \quad \tau'' = \tau(m-2), \quad (5.2.2-10)$$

25 and recover the prior to the last frame's delay as computed in the encoder by using the delay difference:

$$26 \quad \tau(m-2) = \tau(m) - \text{DELAY} - 16 - \text{DELTADELAY}, \quad (5.2.2-11)$$

27 where DELTADDELAY is the received delay difference transmission code, and  $\tau(m)$  is the current frame  
28 delay parameter.

29  $E(n)$  is then warped using  $\tau''$  and  $\tau(m-2)$  in 5.2.2.3.2 and 5.2.2.3.3 for each subframe  $0 \leq m' < 3$ .

1 E(n) is then further warped using  $\tau(m-2)$  and  $\tau(m-1)$  in 5.2.2.3.2 and 5.2.2.3.3 for each subframe  $0 \leq m' < 3$   
 2 to obtain an adaptive codebook buffer using a recovered delay contour.

### 3 5.2.2.4.2 Reconstruction of the delay contour

4 The reconstructed delay contour,  $\tau_c(n)$ , is generated as defined in Section 4.11.5.1 of the encoder, using a set of  
 5 delay interpolations computed by:

$$\dot{d}^{(m', j)} = \begin{cases} \tau(m-1) & ; | \tau(m-1) - \tau' | > 15, \\ (1-f(m'+j))\tau(m-1) + f(m'+j)\tau' & ; otherwise, \end{cases} \quad 0 \leq j < 3,$$

6  
 7 (5.2.2-12)

8 where  $m$  is the current frame,  $m'$  is the subframe index, and  $m'+j$  is an index into an array of interpolator  
 9 coefficients,  $f$ , defined by:

$$10 \quad f = \{ 0.0, 0.3313, 0.6625, 1.0, 1.0 \}. \quad (5.2.2-13)$$

### 11 5.2.2.4.3 Warping of the adaptive codebook memory

12 The adaptive codebook memory,  $E(n)$ , is then mapped to the delay contour,  $\tau_c(n)$ , as described in 4.11.5.2 of  
 13 the encoder. For the first subframe,  $m'$ , the mapped adaptive codebook memory is scaled by a value  $g$  given by:

$$14 \quad g = \begin{cases} \text{MIN}(g_{avg}, 0.95); & \text{for } m' = 0 \\ 0.95; & \text{otherwise} \end{cases}$$

15 where  $g_{avg}$  is the average adaptive codebook gain value.

16

### 17 5.2.2.5 Smoothing of the Decoded Delay

18 The delay of the previous frame,  $\tau(m-1)$ , shall be smoothed for delay interpolation in 5.2.3.4 by:

$$19 \quad \tau(m-1) = \begin{cases} \tau(m) & ; | \tau(m) - \tau(m-1) - \tau' | > 15, \\ \tau(m-1) & ; otherwise, \end{cases} \quad (5.2.2-14)$$

## 20 5.2.3 Rates 1/2 and 1 Subframe Decoding

21 Compute the decoded synthesized speech signal for each subframe,  $0 \leq m' < 3$ , as described in 5.2.3.1  
 22 through 5.2.3.10. The subframe size,  $L$ , is 53 for subframes 0 and 1, and 54 for subframe 2.

### 23 5.2.3.1 Interpolation of LSP Parameters

24 Interpolate the quantized LSPs over the three subframes,  $m'$ , in the current frame,  $m$ . The form of the  
 25 quantized, interpolated LSP vector is:

$$26 \quad \dot{\Omega}_q(m') = (1 - \mu_{m'})\Omega_q(m-1) + \mu_{m'}\Omega_q(m), \quad (5.2.3-1)$$

1 where the subframe interpolator constants are defined as  $\mu = \{ 0.1667, 0.5, 0.8333 \}$ .

2 5.2.3.2 LSP to LPC Conversion

3 Convert the quantized, interpolated LSPs,  $\dot{\Omega}_q(m)$ , to quantized, interpolated LPC parameters,  $\left\{ \dot{a}_q \right\}$ , as  
 4 described in 4.6.2.2 for each subframe.

5 5.2.3.3 Bandwidth Expansion

6 If the decoded *LPCFLAG* transmission code = *TRUE*, and (*FER\_FLAG*(*m* - 1) = *TRUE*), the interpolated LPC  
 7 parameters,  $\left\{ \dot{a}_q \right\}$ , shall be bandwidth expanded using:

8 
$$\dot{a}_q(k) = (0.75)^K \dot{a}_q(k); \quad 1 \leq k < 10. \quad (5.2.3-2)$$

9 5.2.3.4 Interpolated Delay Estimate Calculation.

10 Calculate the set of interpolated delay estimates,  $\dot{d}(m', j)$ , as in 4.11.4.3 of the encoder. If (*FER\_FLAG*(*m*) =  
 11 *TRUE*), and the average adaptive codebook gain (see 5.2.3.5) for the last valid frame, ( $g_{pavg} < 0.3$ ), the  
 12 interpolated delay estimates are defined as:

13 
$$\dot{d}(m', j) = d_{md}(m' + j); \quad 0 \leq j < 3 \quad (5.2.3-3)$$

14 where  $d_{md}(k)$  is the  $k^{\text{th}}$  element of:

15 
$$d_{md} = \{55.0, 80.0, 39.0, 71.0, 33.0\}, \quad (5.2.3-4)$$

16 5.2.3.5 Calculation of the Adaptive Codebook Contribution

17 The average adaptive codebook gain,  $g_{pavg}$  is computed by:

18 5.2.3.5.1 SO 3

19 
$$g_{pavg} = \begin{cases} g_{pavg}(m-1) & ; FER\_FLAG(m) = TRUE \text{ and } FER\_FLAG(m-1) = FALSE, \\ 0.75g_{pavg}(m-1) & ; FER\_FLAG(m) = TRUE \text{ and } FER\_FLAG(m-1) = TRUE, \\ \frac{1}{3} \sum_{i=0}^2 g_p(i) & ; FER\_FLAG(m) = FALSE, \end{cases} \quad (5.2.3-5)$$

1 5.2.3.5.2 SO 68

$$2 \quad g_{pavg} = \begin{cases} g_{pavg}(m-1) & ; FER\_FLAG(m) = TRUE \text{ and } FER\_FLAG(m-1) = FALSE \\ 0.75g_{pavg}(m-1) & ; FER\_FLAG(m) = TRUE \text{ and } FER\_FLAG(m-1) = TRUE \\ \frac{g_p(0) + 2g_p(1) + 3g_p(2)}{6} & ; FER\_FLAG(m) = FALSE \end{cases}$$

3 where  $g_{pcb}(k)$  is an entry in the adaptive codebook gain quantization Table 4.11.4.9-1, and  $ACBGIDX(m')$  is the  
4 decoded adaptive codebook gain index.

5 The adaptive codebook gain,  $g_p(m')$ , shall be defined as:

$$6 \quad g_p(m') = \begin{cases} g_{pavg}(m) & ; FER\_FLAG(m) = TRUE , \\ g_{pcb}(ACBGIDX(m')) & ; FER\_FLAG(m) = FALSE , \end{cases} \quad (5.2.3-6)$$

7 For SO 68, if the previous frame was erased, and was processed as a silence or a NELP frame, then the current  
8 frame adaptive codebook gain,  $g_p(m')$  is set to zero.

9 Calculate the adaptive codebook excitation,  $E(n)$ , as described in 4.11.5 of the encoder.

10 5.2.3.6 Calculation of the Fixed Codebook Gain

11 The fixed codebook gain,  $g_c(m')$ , is defined as:

$$12 \quad g_c(m') = \begin{cases} g_{cavg} & ; FER\_FLAG(m) = TRUE , \\ g_{ccb}(FCBGIDX(m')) & ; otherwise , \end{cases} \quad (5.2.3-7)$$

13 where the average fixed codebook gain,  $g_{cavg}$ , is defined by:

$$14 \quad g_{cavg} = \frac{1}{3} \sum_{i=0}^2 g_c(i) , \quad (5.2.3-8)$$

15 calculated over  $g_c(i)$  for the last valid frame;  $g_{ccb}(k)$  is an entry in the fixed codebook gain quantization Table  
16 9-15, and  $FCBGIDX(m')$  is the fixed codebook gain index.

17 5.2.3.7 Computing of the Reconstructed ACELP Fixed Codebook Excitation for SO 3

18 If ( $FER\_FLAG(m) = TRUE$ ), the ACELP contribution is  $c(n) = 0$  ;  $0 \leq n \leq 54$ , otherwise generate the fixed  
19 codebook contribution as follows:

20 For Rate 1 frames, the position of the two-single-pulse tracks,  $q$ , is determined by using  $FCBSIDX(m',3)[9,10]$   
21 as given in Table 4.11.7.2.2-1. The remaining three tracks correspond to double-pulse tracks.

22 The single and double-pulse track positions in the decimated domain, for  $0 \leq i \leq 3$ , are determined by:

$$23 \quad \lambda_0 = \left\lfloor \frac{FCBSIDX(m',i)[0, \dots, 6]}{11} \right\rfloor , \quad (5.2.3-9)$$

$$\lambda_1 = FCBSIDX(m', i)[0, \dots, 6] - 11\lambda_0. \quad (5.2.3-10)$$

The sign of the three double-pulse tracks is determined by using the relationship between  $\lambda_0$  and  $\lambda_1$  as well as  $FCBSIDX(m', i)$  [7] for  $i = 0, 1, 2$ . If  $\lambda_0 < \lambda_1$ , then the two pulses have the same sign, as specified by  $FCBSIDX(m', i)$  [7]. If  $\lambda_0 > \lambda_1$ , then the two pulses have different signs, and  $FCBSIDX(m', i)$  [7] specifies the sign of the pulse at position  $\lambda_0$  as described in 4.11.7.3. The sign of the two single-pulse tracks is given by the codeword  $FCBSIDX(m', 3)$  [7] and  $FCBSIDX(m', 3)$  [8], accordingly.

Next, referring to Equations 4.9.7.3-1 and 4.9.7.3-2 and Table 4.11.7.1-1 and Table 4.11.7.2.2-1, the pulse positions in the decimated domain shall be converted to the undecimated domain.

For Rate 1/2,  $FCBSIDX(m', 0)$  [9] indicates the sign of the first and the third pulse track, and the opposite sign of the 2nd pulse track, and  $FCBSIDX(m', 0)$  [0, ..., 8] indicates the positions of three pulses in the three tracks accordingly, as given in the Table 4.11.7.4-1.

The received algebraic codebook index is used to extract the positions and amplitudes (signs) of the excitation pulses and to construct the algebraic codevector,  $c$ , according to Equation 4.9.7.1-1. If the pitch delay,  $\tau$ , is less than the subframe size 55, the pitch sharpening processing shall be applied which modifies  $c(n)$  by  $c(n) = c(n) + g_p c(n - \tau)$ , where  $g_p$  is the decoded pitch gain bounded by [0.2, 0.9].

#### 5.2.3.8 Computing of the reconstructed fixed codebook excitation in SO 68

If (FER\_FLAG(m) = TRUE), the FACTORIAL CODEBOOK contribution is  $c(n) = 0$ ;  $0 \leq n \leq 54$ , otherwise generate the fixed codebook contribution as follows:

For Rate 1 frames, the Fixed codebook codeword is converted to the fixed codebook vector,  $c(n)$  as described in Section 4.11.4.11.

For Rate 1/2, the Fixed codebook codeword is converted to the fixed codebook vector,  $c(n)$  as described in Section 4.11.4.11.

If the pitch delay,  $\tau$ , is less than the subframe size 55, the pitch sharpening processing shall be applied which modifies  $c(n)$  by  $c(n) = c(n) + g_p c(n - \tau)$ , where  $g_p$  is the decoded pitch gain bounded by [0.2, 0.9].

#### 5.2.3.9 Decoder Total Excitation Generation

Add the fixed and adaptive codebook contributions to obtain the total excitation,  $E_T(n)$ , for the current frame as defined by:

$$E_T(n) = \begin{cases} g_p E(n); & FER\_FLAG(m) = TRUE, \\ g_p E(n) + g_c c(n); & otherwise, \end{cases}; 0 \leq n < L. \quad (5.2.3-11)$$

#### 5.2.3.10 Adaptive Codebook Memory Update

Update the adaptive codebook excitation memory with the combined excitation for the current subframe,  $E_T(n)$ , excluding any random excitations added in 5.2.3.10:

$$E_T(n) = \begin{cases} E(n+L); & -128 \leq n < -L, \\ E_T(n+L); & -L \leq n < 0. \end{cases} \quad (5.2.3-12)$$

1 If ( $FER\_FLAG(m) = FALSE$ ), and the current subframe,  $m' = 2$ , update the last valid excitation memory buffer,  
 2  $E_{lv}(n)$  with the adaptive codebook memory:

$$3 \quad E_{lv}(n) = E(n-128); \quad 0 \leq n < 128. \quad (5.2.3-13)$$

#### 4 5.2.3.11 Additional Excitation Frame Processing

5 A fade scaling variable,  $\alpha_f$ , shall be calculated every subframe as defined by:

$$6 \quad \alpha_f = \begin{cases} \alpha_f - 0.05; & FER\_FLAG(m) = TRUE, \\ \alpha_f + 0.2; & otherwise, \end{cases} \quad (5.2.3-14)$$

7 where  $\alpha_f$  is bounded by  $0 \leq \alpha_f \leq 1$ , and is used to scale the combined excitation:

$$8 \quad E_T(n) = \alpha_f E_T(n); \quad 0 \leq n < L. \quad (5.2.3-15)$$

9 If ( $FER\_FLAG(m) = TRUE$ ), or if the frame is a special packet-level signaling half-rate CELP frame for SO 68,  
 10 and the average adaptive codebook gain, ( $g_{pavg} < 0.4$ ), a random fixed codebook excitation is added to the  
 11 combined excitation:

$$12 \quad E_T(n) = E_T(n) + 0.1 g_{cavg} \text{ran\_g}\{seed\}; \quad 0 \leq n < L, \quad (5.2.3-16)$$

13 where  $g_{cavg}$  is calculated in 5.2.3.6 for the last valid frame, and  $\text{ran\_g}\{seed\}$  is a unit variance pseudo-random  
 14 Gaussian white noise sequence (see 4.7.2).

#### 15 5.2.3.12 Frame expansion or compression in CELP frames in SO 68

16 To interface to dynamic jitter buffer mechanisms used in Packet Switched networks, CELP decoder In SO 68  
 17 can output more than or less than 160 samples. When it is needed to output less than 160 samples, CELP  
 18 decoder generates 160-DELAY samples of total excitation as described below.

$$19 \quad E_T(n) = \begin{cases} \frac{(merge\_stop - n)}{merge\_stop} E_T(n) + \frac{n}{merge\_stop} E_T(n + merge\_end); & 0 \leq n < merge\_stop \\ E_T(n + merge\_end); & merge\_stop \leq n < 160 - merge\_end \end{cases}$$

20 where,

21  $merge\_end = DELAY$ , and

$$22 \quad merge\_stop = \begin{cases} merge\_end; & merge\_end \leq 80 \\ 160 - merge\_end; & merge\_end > 80 \end{cases}$$

23 When more than 160 samples are needed, CELP generates 160+DELAY samples of total excitation as  
 24 described below.

$$E_T(n) = \begin{cases} E_T(n); & 0 \leq n < \text{merge\_end} \\ \frac{(\text{merge\_stop} - n)}{\text{merge\_stop}} E_T(n) + \frac{n}{\text{merge\_stop}} E_T(n - \text{merge\_end}); & \text{merge\_end} \leq n < \text{merge\_end} + \text{merge\_stop} \\ E_T(n - \text{merge\_end}); & \text{merge\_end} + \text{merge\_stop} \leq n < 160 + \text{merge\_end} \end{cases}$$

where,

$\text{merge\_end} = \text{DELAY}$ , and

$$\text{merge\_stop} = \begin{cases} \text{merge\_end}; & \text{merge\_end} \leq 80 \\ 160 - \text{merge\_end}; & \text{merge\_end} > 80 \end{cases}$$

### 5.2.3.13 PPP smoothing of CELP frame after erasure in SO 68

In order to smooth some phase discontinuities between a past erasure frame and a good CELP frame, PPP synthesis is employed to smooth such a transition.

Using a PPP DFS,  $\text{CURRP\_Q}$ , obtained from the last L (pitch lag of current frame) values of the current constructed total excitation, and the previous DFS,  $\text{PREV\_PPP}$ , obtained from the last pitch lag (of previous frame) of samples from excitation of the previous frame we generate the 160 samples of the current frame excitation,  $E_T(m)$ , similar to the method described in Section 4.12.30.4.

The above mentioned PPP smoothing is disabled if there is a significant change (either increase or decrease) between the energies of  $\text{CURRP\_Q}$ , and  $\text{PREV\_PPP}$  referred to in this section.

### 5.2.3.14 Pitch Prefilter (SO 70 WB mode)

The combined excitation vector,  $E_T(n)$ , for the current subframe,  $m'$  is filtered through a pitch enhancement filter prior to input to the LPC synthesis filter and high band synthesis processing. The pitch enhancement filter is a time varying filter of the form:

$$P(z, n) = \frac{1}{1 - 0.4g_p z^{-\tau_c(n)}}; \quad 0 \leq n < L, \quad (5.2.3-17)$$

where  $\tau_c(n)$  is the delay contour obtained from interpolating the delay adjusted endpoints,  $\dot{d}(m', 0)$  to  $\dot{d}(m', 1)$ , as in 4.11.5.1. The filter uses an 8x oversampling fractional pitch interpolation similar to that used for generating the adaptive codebook contribution. This notation, however, is a mix of time domain and z-transform symbols, where the  $z^{-1}$  operator is to be viewed as a unit delay operator rather than a z-transform. The state of this filter is reset to all zeros on subframe  $m' = 0$  when the previous frame was not RCELP Rate 1 or Rate 1/2, or if the previous frame was an erasure. In addition, the energy of the output of the pitch enhancement filter is normalized to the input energy. The output of the filter overwrites the previous values of  $E_T(n)$ , therefore it is critical to update the adaptive codebook memory prior to running this filter. This filter is not run if  $\text{FER\_FLAG}(m) = \text{TRUE}$ , and the state is reset to all zeros.

1 5.2.3.15 Synthesis of the decoder output signal

2 Filter the combined excitation,  $ET(m)$ , through the synthesis filter using the interpolated LPCs generated in  
 3 Section 5.2.3.2, creating the synthesized speech signal,  $\hat{s}(n)$ . The synthesis filter for the decoder,  $H_q(z)$ , is  
 4 defined by:

$$H_q(z) = \frac{1}{A_q(z)} = \frac{1}{1 - \sum_{k=1}^{10} a_q(k)z^{-k}} \quad (5.2.3-18)$$

6 The signal,  $\hat{s}(n)$ , shall be post-filtered according to Section 5.8, producing the post-filtered synthesized speech  
 7 signal,  $\hat{s}_{pf}(n)$ .

8

9 5.2.3.16 Synthesis of the Decoder Output Signal

10 Filter the combined excitation,  $E_f(m)$ , through the synthesis filter using the interpolated LPCs generated in  
 11 5.2.3.2, creating the synthesized speech signal,  $\hat{s}(n)$ . The synthesis filter for the decoder,  $H_q(z)$ , is defined by:

$$H_q(z) = \frac{1}{A_q(z)} = \frac{1}{1 - \sum_{k=1}^{10} a_q(k)z^{-k}} \quad (5.2.3-19)$$

13 The signal,  $\hat{s}(n)$ , shall be post-filtered according to 5.4, producing the post-filtered synthesized speech  
 14 signal,  $\hat{s}_{pf}(n)$ .

15 **5.3 Rate 1 and Rate 1/4 PPP decoding (FPPP and QPPP) for SO 68**

16 5.3.1 Decoding of the LSP parameters in FPPP

17 If (FER\_FLAG(m) = TRUE), use the LSP parameters from the last frame to generate bandwidth expanded  
 18 LSPs for the current frame as follows:  $\Omega_q(m) = 0.875 \Omega_q(m-1) + 0.125 \Omega_{spread}$  where  $\Omega_{spread}$  are the initial  
 19 values of the LSPs, as defined in Section 5.2.

20 Otherwise, decode the LSP parameters,  $\Omega_q(m)$  using the decoded LSP indices, LSPIDX(k). In the event that  
 21 the decoded LSPs are not strictly ascending, FER\_FLAG(m) shall be set to TRUE, where “strictly ascending”  
 22 is defined as  $\Omega_q(m, i) < \Omega_q(m, i+1)$ ;  $1 \leq i \leq 9$ .

23 5.3.2 Decoding of the LSP parameters in QPPP

24 A second order moving average (MA) predictor is used for quantizing the LSPs in quarter-rate voiced frame  
 25 processing.

26 The MA predictive quantizer ensures that the effect of frame errors discontinues after 2 frames. The quantized  
 27 LSP vector at the mth frame is given as

$$\hat{\mathbf{L}}_m = 0.4\mathbf{C}_m + 0.4\mathbf{C}_{m-1} + 0.2\mathbf{C}_{m-2} \quad (5.3.2-1)$$

29 where  $\mathbf{C}_m$  is the codebook vector for the mth frame is constructed as follows:

$$C_m(i) = \begin{cases} CB1[i_1^*][i]; & 0 \leq i < 6 \\ CB2[i_2^*][i-6]; & 6 \leq i < 10 \end{cases}$$

where  $i_1^*$ , and  $i_2^*$  be the LSP codebook indices obtained from the QPPP packet for the two splits.

The LSP parameters,  $\Omega_q(m)$ , are elements of the vector L.

### 5.3.3 Delay decoding in FPPP

The delay parameter, L, for the current frame is defined as:

$$L(m) = DELAY + 20 \quad (5.3.3-1)$$

where DELAY is the pitch delay transmission code.

### 5.3.4 Delay decoding in QPPP

The delay parameter, L, for the current frame is defined as:

$$L(m) = DELTADelay - 7 + PREV\_DELAY \quad (5.3.4-1)$$

where DELTADelay is the pitch delay transmission code, and PREV\_DELAY is the decoded delay parameter of the previous frame (same as L(m-1)).

### 5.3.5 Previous frame delay PPP (QPPP and FPPP)

The delay value, PL, of the previous frame is defined as:

$$PL = \begin{cases} L(m) & ; \text{if previous frame was Rate 1/4 unvoiced or Rate 1/8} \\ L(m-1) & ; \text{otherwise} \end{cases}$$

PL is further conditioned as follows

$$PL = \begin{cases} PL / 2; & \text{if } PL > 1.85L \\ PL \cdot 2; & \text{if } PL \leq 0.54L \text{ AND } PL < 127 / 2 \\ PL; & \text{otherwise} \end{cases}$$

### 5.3.6 Interpolation of LSP parameters and LSP to LPC conversion

Interpolate the quantized LSPs over the three subframes,  $m'$ , in the current frame,  $m$ . The form of the quantized, interpolated LSP vector is:

$$\dot{\Omega}_q(m') = (1 - \mu_{m'})\Omega_q(m-1) + \mu_{m'}\Omega_q(m), \quad (5.3.6-1)$$

where the subframe interpolator constants are defined as  $\mu = \{ 0.1667, 0.5, 0.8333 \}$ .

Convert the quantized, interpolated LSPs,  $\Omega_q(m)$ , to quantized, interpolated LPC parameters,  $\{ \dot{a}_q \}$ , as

described in Section 4.6.2.1, and Section 4.6.2.2 for each subframe.

1 The quantized interpolated LPC parameters at the end of the previous frame, and the current frames are used in  
 2 the synthesis of the current frame of residual.

### 3 5.3.7 Restoring PPP memories if last frame is non-PPP or full-rate PPP

4 The past-frame memory required for PPP processing is restored as was done in the encoder described in Section  
 5 4.12.25.

### 6 5.3.8 ERB amplitude dequantization of full-rate PPP

7 The ERB amplitudes are created from the Amplitude Quantization Indices as described in Section 4.12.29 to  
 8 obtain the current PPP DFS  $CURRP\_Q_p$  in the polar form.

### 9 5.3.9 Phase dequantization of full-rate PPP or Special Half-rate PPP (packet level signaling) frame

10 The phases of DFS,  $CURRP\_Q_p$ , is set to zero as follows:

$$11 \quad CURRP\_Q_p \cdot b(k) = 0; \quad 0 \leq k \leq \lfloor L/2 \rfloor \quad (5.3.9-1)$$

12  $CURRP\_Q_p$ , is converted to Cartesian representation as shown in Section 4.12.9, and then converted to the  
 13 perceptually weighted domain by pole-filtering using  $A_w$ , the weighted LPC filter,  
 14  $A_w(k) = A(k)(0.8^k)$ ,  $0 \leq k < 9$ . Lets identify the resulting DFS' by  $CURRP\_Q_s$ .

15  $CURRP\_Q_s$  is then shifted by the negative of the global alignment, *alignment*, obtained from the received  
 16 packet as described in Section 4.12.6.

17 The band alignments from the received packets are then applied to  $CURRP\_Q_s$ , according to the following  
 18 equations:

$$\begin{aligned}
 CURRP\_Q_S.a(k) &= \left[ \begin{array}{c} CURRP\_Q_S.a(k) \cos \left( -k \frac{2\pi}{L} \eta \left( -\frac{16}{\eta} + band\_alignment(j) \right) \right) \\ CURRP\_Q_S.b(k) \sin \left( -k \frac{2\pi}{L} \eta \left( -\frac{16}{\eta} + band\_alignment(j) \right) \right) \end{array} \right] - \\
 CURRP\_Q_S.s.b(k) &= \left[ \begin{array}{c} CURRP\_Q_S.a(k) \sin \left( -k \frac{2\pi}{L} \eta \left( -\frac{16}{\eta} + band\_alignment(j) \right) \right) \\ CURRP\_Q_S.b(k) \cos \left( -k \frac{2\pi}{L} \eta \left( -\frac{16}{\eta} + band\_alignment(j) \right) \right) \end{array} \right] + \\
 0 \leq k &\leq \left\lfloor \frac{L}{2} \right\rfloor
 \end{aligned}$$

$$0 \leq j < 17$$

$$-\frac{16}{\eta} \leq n < \frac{16}{\eta}; n \text{ increasing in steps of } 1$$

for every  $j$ ,

$$k \in \left[ 0, \left\lfloor \frac{L}{2} \right\rfloor \right] \text{ such that } lband(j) \leq k \frac{8000}{L} < hband(j)$$

$$\text{where, } \eta = \begin{cases} 1; & j < 3 \\ 0.5; & 3 \leq j < 17 \end{cases}$$

and,  $lband(j) = F\_BAND[j]$

$hband(j) = F\_BAND[j+1]$

If the frame is a special HPPP frame, the band alignments used in the above equation are not present in the input packet but instead are given by:

$$band\_alignment(j) = \begin{cases} 16; & j < 3 \\ 32; & \text{otherwise} \end{cases}$$

$CURRP\_Q_S$  is then zero filtered using the procedure in Section 4.12.5, and  $A_w$ , the weighted LPC filter,  $A_w(k) = A(k)(0.8^k)$ ,  $0 \leq k < 9$  to obtain the quantized full-rate PPP DFS,  $CURRP\_Q$

### 5.3.10 Obtaining the dequantized current DFS in QPPP

The ERB amplitudes of the QPPP frames are decoded as described in Section 4.12.28.3. The amplitude dequantized current PPP DFS,  $CURRP\_Q_p$ , is then obtained as described in Section 4.12.28.5  $CURRP\_Q_p$ .

### 5.3.11 Copying the phase spectrum of previous PPP DFS

In quarter-rate PPP, the phase of the current DFS is set to be equal to the phase of the previous DFS after it is extended into the current frame. That is, the phase of  $CURRP\_Q_p$  (which is in polar form) is obtained as follows:

$$CURRP\_Q_p.b(k) = ACB_p.b(k); \quad 0 \leq k \leq \left\lfloor L/2 \right\rfloor \quad (5.3.11-1)$$

where  $ACB_p$  is the polar representation of  $ACB$ .

1 The Cartesian representation of yields the DFS of the current PPP,  $CURRP\_Q$ , that is to be used in the  
2 synthesis of the whole frame of excitation.

### 3 5.3.12 PPP synthesis

4 Now that we have the quantized current PPP DFS,  $CURRP\_Q$ , and the previous DFS,  $PREV\_PPP$ , we  
5 generate the 160 samples of the current frame excitation,  $ET(m)$ , similar to the method described in Section  
6 4.12.30.4.

#### 7 5.3.12.1 Frame expansion or compression in PPP synthesis

8 To interface to dynamic jitter buffer mechanisms used in Packet Switched networks, Rate  $\frac{1}{4}$  PPP and Rate 1  
9 PPP synthesis can output more than or less than 160 samples. When it is needed to output less than 160  
10 samples, PPP generates  $160-L$  samples. When more than 160 samples are needed, PPP generates  $160+L$   
11 samples.

#### 12 5.3.13 Synthesis of the decoder output signal in PPP

13 Filter the excitation,  $ET(m)$ , through the synthesis filter using the interpolated LPCs generated in 5.2.3.2,  
14 creating the synthesized speech signal,  $\hat{s}(n)$ . The synthesis filter for the decoder,  $H_q(z)$ , is defined by:

$$15 \quad H_q(z) = \frac{1}{A_q(z)} = \frac{1}{1 - \sum_{k=1}^{10} a_q(k)z^{-k}} \quad (5.3.13-1)$$

16 The signal,  $\hat{s}(n)$ , shall be post-filtered according to Section 5.8, producing the post-filtered synthesized speech  
17 signal,  $\hat{s}_{pf}(n)$ .

## 18 5.4 Decoding at Rate 1 Generic Audio for SO 70

### 19 **Inputs:**

- 20 • The quantized LSP indices,  $LSPIDX(k)$
- 21 • The quantized MDCT coefficient (residual line spectrum) index,  $RLSIDX$
- 22 • The quantized global scale factor index,  $GSFIDX$
- 23 • The quantized Noise Injection level indices,  $NILIDX$

### 24 **Output:**

- 25 • The residual excitation signal,  $\varepsilon'_q(n)$

### 26 **Initialization:**

27 The following state variables shall be set to zero at initialization (frame  $m = 0$ ):

- 28 • The formant emphasis and de-emphasis filter memories
- 29 • The IMDCT overlap-and-add buffer,  $y_{ov}(n)$

30

1 **Processing:** Figure 5.4-1 depicts the Generic Audio decoding system that is described in the following  
 2 sections. This output signal  $\varepsilon'_q(n)$  is substituted for the decoded RCELP Rate 1 and Rate 1/2 excitation signal  
 3  $E_T(n)$  in 5.2.3.9. All remaining processing follows from that point.

4

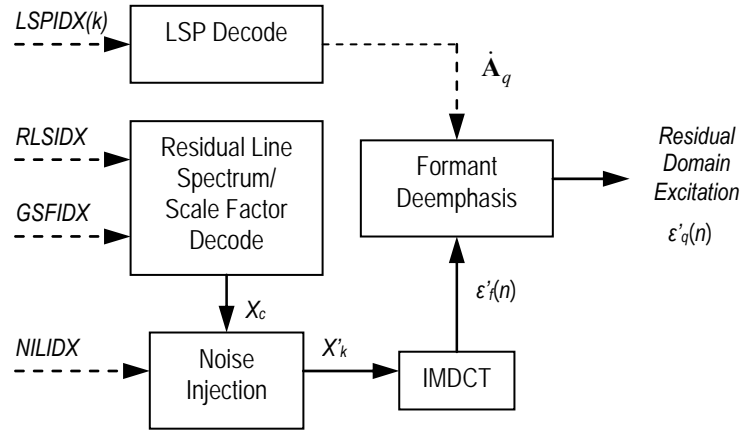

5

6

7

**Figure 5.4-1 Rate 1 Generic Audio Decoding Block Diagram**

8

9 5.4.1 MDCT Residual Line Spectrum Decoding

10 The MDCT coefficients, referred to as the residual line spectrum, are decoded from *RLSIDX* in a similar manner  
 11 to the FCB factorial codebook of 4.11.8.3. The decoded residual line spectrum is designated as  $X_{cc}$ .

12 5.4.2 Global Scale Factor Decoding

13 The decoded global scale factor is given as:

14 
$$e_q = e_{q\min} + e_{bias} + GSFIDX \cdot \Delta_{eq}, \quad (5.4.2-1)$$

15 where the terms are described in 0. The scale factor is then applied to the decoded residual line spectrum  $X_{cc}$  to  
 16 obtain the scaled residual line spectrum  $X_c$ , given as:

17 
$$X_c = 10^{-e_q/20} X_{cc}. \quad (5.4.2-2)$$

18 5.4.3 Noise Injection Decoding

19 The noise injection decoding process parallels the encoding processes described in 4.13.7. A zero detection  
 20 mask is first produced to control whether or not regions of the scaled line spectrum shall be injected with noise.  
 21 The mask is represented as a 160 element column vector  $\mathbf{z}_d$  that is defined as:

22 
$$z_d(k) = \begin{cases} 1; & 40 \leq k \leq 143 \text{ and } X_c(k) = 0 \\ 0; & \text{otherwise} \end{cases}. \quad (5.4.3-1)$$

23 The noise injection gain is then decoded using a lookup table, so that:

1 
$$\gamma_{ni} = \gamma_{ni\_table}[NILIDX], \tag{5.4.3-2}$$

2 and subsequently used to generate the noise injected residual line spectrum  $X'_k$  as:

3 
$$X'_k = \begin{cases} \gamma_{ni} 10^{-e_q/20} rand(); & 40 \leq k \leq 143 \text{ and } z_d(k) == 1, \\ X_c(k); & \text{otherwise} \end{cases}, \tag{5.4.3-3}$$

4 where all terms are previously defined.

5 **5.4.4 Inverse Modified Discrete Cosine Transform (IMDCT)**

6 The process of 4.13.8 is duplicated here to produce  $\varepsilon'_f(n)$ .

7 **5.4.5 Formant Deemphasis**

8 The process of 4.13.9 is duplicated here to produce  $\varepsilon'_q(n)$ . This signal is then substituted for the RCELP Rate  
9 1 and Rate 1/2 excitation signal  $E_T(n)$  in 5.2.3.9. All remaining processing follows from that point.

10 **5.5 Decoding of rate 1/4 unvoiced decoding or special rate-1/2 NELP decoding SO 68 and rate 1/2**  
11 **unvoiced decoding SO 70**

12  
13

14 The decoding of Rate 1/4 unvoiced or the Special Rate 1/2 NELP frame is depicted in Figure 5.5-1.

15

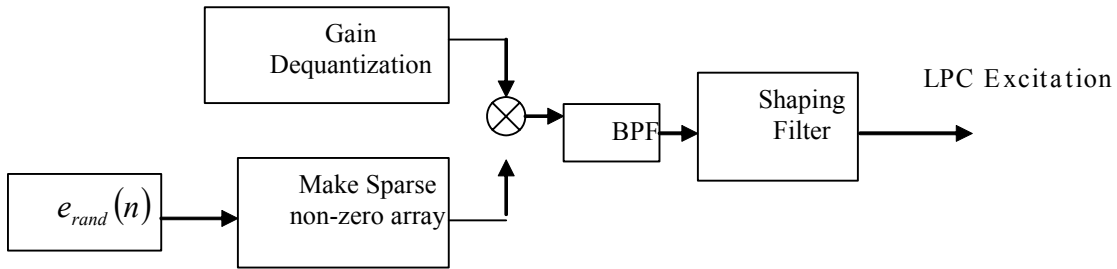

16

17 **Figure 5.5-1 Excitation decoding for rate 1/4 NELP or rate 1/2 special NELP**

18 The gain indices  $i\hat{G}'$ , and  $i\hat{G}''[j], 0 \leq j < 2$ , and the shaping filter index  $F_{idx}$  are decoded from the bitstream  
19 input to the decoder. The gains are dequantized using Equations (4.14.1-5) and (4.14.1-8). A pseudo-random  
20 vector,  $e_{rand}(n)$ , is generated as described in Section 4.14.2. As described in Section 4.14.3, this pseudo-  
21 random vector is used to generate a gain scaled sparse signal,  $r_1(n)$ , which is then shaped by the bandpass filter  
22  $BP(z)$ , and the shaping filter  $SF(z)$  to yield the Rate 1/4 frame LPC excitation. As shown in Equation  
23 (4.14.4-9), the index of the filter,  $F_{idx}$ , is used to establish  $SF(z)$ . The Rate 1/4 unvoiced frame excitation is  
24 then filtered by the LP synthesis filter and the post-processing filter to generate speech.

5.5.1 Frame expansion or compression in Rate ¼ NELP decoding

To interface to dynamic jitter buffer mechanisms used in Packet Switched networks, Rate ¼ NELP frames can output more than or less than 160 samples. When it is needed to output less than 160 samples, Rate ¼ NELP puts out 128 samples. When more than 160 samples are needed, Rate ¼ NELP puts out 192. samples.

For compression, the number of subframes of Rate ¼ NELP used are 8. Specifically, only first 8 gain values are used in the excitation generation.

For expansion, the number of subframes of Rate ¼ NELP used are 12. Specifically, the two extra gain values used in the excitation generation are set to the last subframe’s gain value in the decoded packet. That is,  $\hat{G}(10) = \hat{G}(11) = \hat{G}(9)$ .

**5.6 Rate 1/8 Decoding**

**Inputs:** The inputs to Rate 1/8 decoding are:

- The quantized LSP indices from the current frame,  $LSPIDX(k)$
- The quantized LSPs from the previous frame,  $\Omega_q(m-1)$
- The vector quantized frame energy index,  $FGIDX(m)$
- The vector quantized frame energy index from the last frame,  $FGIDX(m - 1)$
- The frame erasure flag,  $FER\_FLAG(m)$ , for the current frame  $m$

**Outputs:** The outputs from Rate 1/8 decoding are:

- The post-filtered synthesized speech signal,  $\hat{s}_{pf}(n)$

**State Variables:**

None.

**Processing:**

Rate 1/8 decoding shall comprise 5.6.1 to 5.6.5.

5.6.1 Decoding of the LSP parameters

If ( $FER\_FLAG(m) = TRUE$ ), use the LSP parameters from the last frame,  $\Omega_q(m) = \Omega_q(m-1)$ . Otherwise, decode the LSP parameters,  $\Omega_q(m)$ , as defined in 4.9.5, using the decoded  $LSPIDX(k)$ . In the event that the decoded LSPs are not strictly ascending,  $FER\_FLAG(m)$  shall be set to  $TRUE$ , where “strictly ascending” is defined as  $\Omega_q(m, i) < \Omega_q(m, i+1) ; 1 \leq i \leq 9$ .

5.6.2 Decoding of the Frame Energy Vector for SO 3

If ( $FER\_FLAG(m) = FALSE$ ), the frame energy vector,  $\gamma_q(m')$ , shall be defined as:

$$\gamma_q(m') = 10^{q_{\log}(m', FGIDX(m))}; \quad 0 \leq m' < 3, \tag{5.6.2-1}$$

where  $q_{\log}(m', FGIDX)$  is an entry in the gain quantization codebook found in Table 9-18.

If ( $FER\_FLAG(m) = TRUE$ ), the frame energy vector,  $\gamma_q(m')$ , is calculated by:

$$\gamma_q(m') = \frac{1}{3} \sum_{i=0}^2 10^{q \log(i, FGIDX(m-1))}; \quad 0 \leq m' < 3, \quad (5.6.2-2)$$

where  $FGIDX(m-1)$  is the codebook index from the last Rate 1/8 packet in which  $FER\_FLAG$  was  $FALSE$ .

### 5.6.3 Decoding of the Frame Energy Gain for SO 68 and SO 70 NB mode

If ( $FER\_FLAG(m) = FALSE$ ), the frame energy vector,  $\gamma_q(m')$ , is defined as in Section 4.15.6.

If ( $FER\_FLAG(m) = TRUE$ ), the frame energy vector,  $\gamma_q(m')$ , is calculated by:

$$\gamma_q(m') = 10^{\left(\frac{LG0+LG1+LG2}{3}\right)} \quad (5.6.3-1)$$

where,

$$LG2 = \sqrt{\frac{\sum_{j=-128}^{-2 \times 54} (E_T(j))^2}{128 - 2 \times 54}}$$

$$LG1 = \sqrt{\frac{\sum_{j=-54 \times 2 - 1}^{-54} (E_T(j))^2}{54}}$$

$$LG0 = \sqrt{\frac{\sum_{j=-53}^0 (E_T(j))^2}{54}}$$

where  $E_T$  is the adaptive codebook vector mentioned in Section 5.2.3.10.

### 5.6.4 Decoding of the Frame Energy Gain for SO 70 WB mode

If ( $FER\_FLAG(m) = FALSE$ ), the frame energy,  $\gamma_q(m)$ , is defined as:

$$\gamma_q(m) = \begin{cases} \exp(\text{LOGZEROENERGY}_{wb}) & ; FGIDX == 0 \\ \exp\left(\text{MINLOGE}_{wb} + FGIDX \cdot \left(\frac{\text{MAXLOGE}_{wb} - \text{MINLOGE}_{wb}}{\text{NUMQLEVELS}_{wb}}\right)\right) & ; \text{otherwise} \end{cases}, \quad (5.6.4-1)$$

where  $\text{LOGZEROENERGY}_{wb} = -2$ . If ( $FER\_FLAG(m) = TRUE$ ), the frame energy,  $\gamma_q(m)$ , is simply repeated from the previous Rate 1/8 frame, or  $\gamma_q(m) = \gamma_q(m-1)$ . The frame energy is then smoothed and attenuated according to:

$$\tilde{\gamma}_q(m) = \begin{cases} \gamma_q(m) & ; m' = 0 \text{ and } ((m-k > 6) \text{ or } (m < 6) \text{ or } (\tilde{\gamma}_q(k) > \gamma_q(m))) \\ 0.97\tilde{\gamma}_q(k) + 0.0048\gamma_q(m) & ; \text{otherwise} \end{cases}, \quad (5.6.4-2)$$

where  $k$  is the frame index of the last eighth rate frame and  $\tilde{\gamma}_q(k)$  is the smoothed energy calculated during the last valid eighth rate frame.

### 5.6.5 Rate 1/8 Subframe Decoding

Compute the decoded synthesized speech signal for each subframe,  $0 \leq m' < 3$ , as described in 5.6.5.1 to 5.6.5.5. The subframe size,  $L$ , is 53 for subframes 0 and 1, and 54 for subframe 2.

#### 5.6.5.1 Rate 1/8 Excitation Generation

Obtain the Rate 1/8 excitation by generating a zero-mean, unit variance pseudo-random Gaussian white noise process (see 4.16.2), which is conditionally scaled by  $\gamma_q(m')$ :

$$E(n) = \gamma_q(m') \text{ran\_g}\{\text{seed}\}; \quad 0 \leq n < L, \quad (5.6.5-1)$$

No attempt is made to synchronize the random time series generated at the receiver with that generated at the transmitter.

#### 5.6.5.2 Interpolation of LSP Parameters

Interpolate the quantized LSPs as in 5.2.3.1. For SO 70 WB mode, the LSPs are further smoothed according to:

$$\tilde{\Omega}(m', i) = 0.9\tilde{\Omega}(m', i) + 0.1\Omega(m', i); \quad 0 \leq i \leq 9, \quad (5.6.5-2)$$

where the smoothed LSP are initialized at frame  $m = 0$  to be  $\tilde{\Omega}(m') = \Omega(m')$ , and the smoothed LSPs are then used to replace the current set of unsmoothed LSPs, or  $\Omega(m') \leftarrow \tilde{\Omega}(m')$ .

#### 5.6.5.3 LSP to LPC conversion

Perform the LSP to LPC conversion as defined in 5.2.3.2.

#### 5.6.5.4 Estimation of the LPC Prediction Gain (for SO 70 WB mode)

Estimate the prediction gain of the smoothed LPC filter by calculating the energy of the filter impulse response  $\tilde{h}(n)$ , and then apply the inverse of the gain to the Rate 1/8 excitation:

$$E(n) \leftarrow \sqrt{\frac{\tilde{\gamma}_q(m)}{\sum_{i=0}^{L-1} (\tilde{h}(i))^2}} E(n); \quad 0 \leq n < L, \quad (5.6.5-3)$$

1 The excitation is now properly gain scaled such that the smoothed frame energy is obtained after application of  
2 the subsequent LPC synthesis filter in the next section.

3

#### 4 5.6.5.5 Synthesis of Decoder Output Signal

5 Filter the Rate 1/8 excitation,  $E(n)$ , through the synthesis filter as in 5.2.3.11. The signal,  $\hat{s}(n)$ , shall be post-  
6 filtered according to 5.4, producing the post-filtered synthesized speech signal,  $\hat{s}_{pf}(n)$ .

### 7 **5.7 Suppressed/Blanked Rate 1/8 decoding SO 68 and SO 70**

#### 8 **Inputs**

9 The frame erasure flag, FER\_FLAG(m), for the current frame m

#### 10 **Outputs**

11 The post-filtered synthesized speech signal,  $\hat{s}_{pf}(n)$ .

#### 12 **State Variables**

13 The background noise estimate,  $E_{bgn}(n)$

#### 14 **Processing**

15 Suppressed Rate 1/8 decoding shall comprise Sections 5.7.1 and 5.7.2. The basic structure of the decoder is  
16 modified as shown in Figure 5.7-1 to incorporate decoding of suppressed rate 1/8 frames. The received packet  
17 is decoded as defined in the previous sections when the rate is not of type 0 (blank or suppressed rate 1/8).  
18 When the received rate is a suppressed rate 1/8 frame, the switch connects the output of the comfort noise  
19 synthesizer and encoder to the decoder to produce the output signal.

20

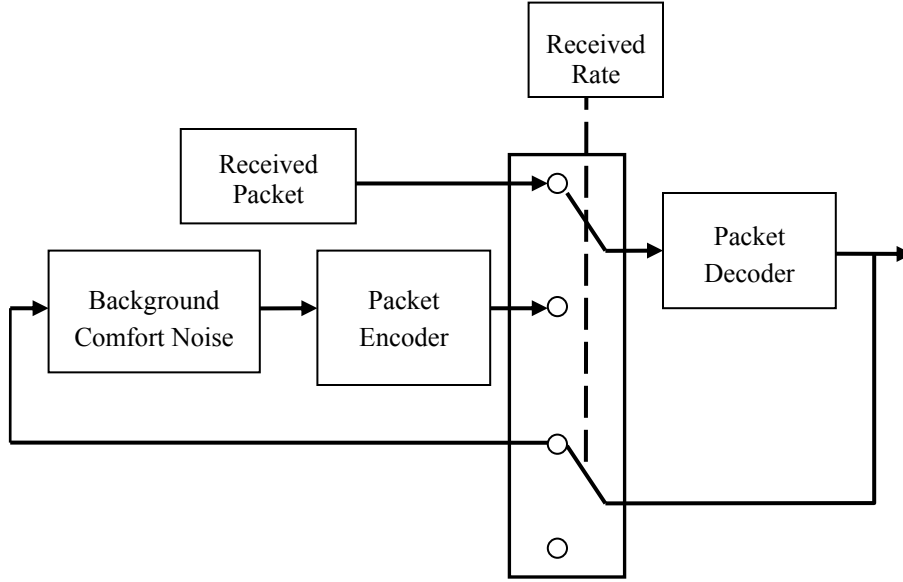

1

2

**Figure 5.7-1 Comfort Noise Synthesizer Block Diagram**

3

4 5.7.1 Synthesizing comfort noise

5 The comfort noise is synthesized from the background noise estimate  $E_{bgn}(n)$ , generated in 5.10.3. The  
 6 frequency domain representation of the noise is computed from the background noise estimate. First, the  
 7 background noise estimate is smoothed to produce

$$E_{bgnSm}(m, i) = \begin{cases} \beta_2 E_{bgnSm}(m-1, i) + (1 - \beta_2) E_{bgn}(m, i) & ; m \geq 10 \\ \beta_{2r} E_{bgnSm}(m-1, i) + (1 - \beta_{2r}) E_{bgn}(m, i) & ; m < 10 \end{cases} \quad (5.7.1-1)$$

9 Next, the magnitude of noise is computed according to:

$$X_{decmag}(k) = 10^{E_{bgn}(m, i)/20} ; f_L(i) \leq k \leq f_H(i), 0 \leq i < N_c \quad (5.7.1-2)$$

11 where  $\beta_2 = 0.9925$ , and  $\beta_{2r} = 0.794$ .

12 with  $f_L(i)$  and  $f_H(i)$ , defined in Section 4.4.3.2, with  $N_c = 16$ . The phase is randomized to produce  
 13  $X_{dec}$ , according to:

$$\phi(k) = \cos(2\pi \cdot \text{ran } 0\{\text{seed}\}) + j \sin(2\pi \cdot \text{ran } 0\{\text{seed}\}) \quad (5.7.1-3)$$

14

$$X_{dec}(k) = X_{decmag}(k) \cdot \phi(k) \quad (5.7.1-4)$$

where ran0 is a uniform pseudo-random number generator as described in 4.16.1. The noise is converted to the time domain using the inverse DFT:

$$x_{dec}(m, n) = \begin{cases} x_{dec}(m-1, n+L-D) + w_g(n) \cdot \frac{1}{2} \sum_{k=0}^{M-1} X_{dec}(k) e^{j2\pi nk/M} & ; 0 \leq n < D \\ w_g(n) \cdot \frac{1}{2} \sum_{k=0}^{M-1} X_{dec}(k) e^{j2\pi nk/M} & ; D \leq n < M. \end{cases} \quad (5.7.1-5)$$

with  $w_g(n)$  defined as:

$$w_g(n) = \begin{cases} \sin^2(\pi(n+0.5)/2D) & ; 0 \leq n < D \\ 1 & ; D \leq n < L \\ \sin^2(\pi(n-L+D+0.5)/2D) & ; L \leq n < L+D \end{cases} \quad (5.7.1-6)$$

### 5.7.2 Generating encoded packet from synthesized noise

To better match the spectral characteristics of Rate 1/8 frames, the synthesized comfort noise  $x_{dec}(m, n)$  is encoded as a Rate 1/8 frame. The encoding process is a simplified version of the one described in chapter 4. First, the synthesized noise from Equation 5.7.1-5 is used to compute the LPC coefficients according to 4.6.1.1 by re-defining  $s'(k)$  as:

$$s'(k) = \begin{cases} x_{dec}(m-1, k) & ; 0 \leq k < 160 \\ x_{dec}(m, k-160) & ; 160 \leq k < 320 \end{cases} \quad (5.7.2-1)$$

Then, the LPC coefficients are converted to LSPs according to 4.6.1.3. The LSPs are interpolated for each subframe and converted back to LPCs according to 4.6.2.1 and 4.6.2.2.

To compute the LPC gain, a short-term residual  $\varepsilon(n)$  is generated according to Equation 4.6.2-10. Then, the impulse response  $h_{noise}$  of the inverse LPC filter for the current subframe  $m'$ , is calculated to the subframe length  $L_{sf}$ . The frame energy gain is determined by:

$$\gamma(m') = \log_{10} \left( \frac{\frac{2}{L_{sf}} \cdot \sum_{n=0}^{L_{sf}-1} |\varepsilon(n)|}{\sqrt{\sum_{n=0}^{L_{sf}-1} h_{noise}^2(n)}} \right) \quad (5.7.2-2)$$

1 The LSPs are vector quantized according to 4.15.1, and the frame energy gain according to 4.15.6. The  
 2 encoded parameters are processed by 5.6.1 through 5.6.5.5 assuming FER\_FLAG(m) is not set to produce the  
 3 decoded output  $\hat{s}(n)$ .

4

### 5 5.8 Adaptive Postfilter for SO 3

6 The Adaptive Postfilter function improves the perceived speech quality of the decoder output. Refer to 1.1 for  
 7 guidelines concerning potential variations of the Adaptive Postfilter.

#### 8 **Inputs:**

- 9 • The decoder synthesis output signal,  $\hat{s}(n)$
- 10 • The quantized, interpolated LPC coefficients,  $A_q(n)$
- 11 • The interpolated pitch delays,  $d(m')$

#### 12 **Output:**

13 The post-filtered synthesis signal,  $\hat{s}_{pf}(n)$

14 **Initialization:** All filter memories shall be initialized to zero at start-up.

15 **Processing:** The decoded speech signal,  $\hat{s}(n)$ , shall be post-filtered by applying the following operations in the  
 16 sequence specified:

- 17 • A tilt-compensation filter  $H_t(z)$
- 18 • A short term residual filter,  $H_{\mathcal{E}}(z)$
- 19 • A long term filter,  $H_p(z)$
- 20 • Gain normalization,  $g_s$
- 21 • A short term filter,  $H_s(z)$

22 The postfilter shall be applied once for each of the three subframes and shall take the form:

$$23 \quad PF(z) = H_s(z)g_sH_p(z)H_{\mathcal{E}}(z)H_t(z). \quad (5.8-1)$$

24 The postfilter residual memory buffer is then updated with the current subframe's residual signal. Each of  
 25 these steps shall be carried out as specified in Sections 5.7.1 to 5.7.5.

#### 26 5.8.1 Tilt Compensation Filter

27 Generate the tilt-compensated speech signal,  $\hat{s}_t(n)$ , by filtering the decoded speech signal,  $\hat{s}(n)$ , through the  
 28 tilt compensation filter given by:

$$29 \quad H_t(z) = 1 - \mu z^{-1}, \quad (5.8.1-1)$$

30 where  $\mu$  is the tilt coefficient calculated by determining if  $\hat{s}(n)$  is voiced or un-voiced. The signal,  $\hat{s}(n)$ , is  
 31 defined as being voiced if:

$$R = \left( \sum_{i=0}^{L-2} \hat{s}(i)\hat{s}(i+1) \right) \geq 0. \quad (5.8.1-2)$$

Using the above result, the tilt coefficient,  $\mu$ , is defined as:

$$\mu = \begin{cases} 0 & ; R < 0, \\ \text{tilt}(\text{Rate}) & ; R \geq 0, \end{cases} \quad (5.8.1-3)$$

where  $\text{tilt}(\text{Rate})$  is defined in Table 5.8.1-1.

**Table 5.8.1-1 Postfilter Coefficients**

<i>Rate</i>	<i>tilt(Rate)</i>	$\gamma_{p1}$	$\gamma_{p2}$
1	0.20	0.57	0.75
1/2	0.35	0.50	0.75
1/8	0	0.57	0.57

### 5.8.2 The Short Term Residual Filter

Compute the postfilter residual,  $\varepsilon_{pf}(n)$ , by filtering the tilted speech signal,  $\hat{s}_t(n)$ , through  $H_{\mathcal{E}}(z)$ , given by:

$$H_{\mathcal{E}}(z) = A_q(\gamma_{p1}^{-1}z) = 1 - \sum_{k=1}^{10} a_q(k) \gamma_{p1}^k z^{-k}, \quad (5.8.2-1)$$

where  $\gamma_{p1}$  is given for each *Rate* in Table 5.8.1-1, and  $\{a_q\}$  are the interpolated LPC parameters for the current subframe.

### 5.8.3 The Long-term Postfilter

Generate the long-term post-filtered signal,  $\hat{s}_p(n)$ , by filtering the residual signal,  $\varepsilon_{pf}(n)$ , through the long term post filter given by:

$$H_p(z) = \begin{cases} 1.0 + g_p g_{lt} z^{-d_{opt}} & ; 0.5 \leq g_p < 1.0, \\ 1.0 + g_{lt} z^{-d_{opt}} & ; 1.0 \leq g_p, \\ 1.0 & ; \text{otherwise,} \end{cases} \quad (5.8.3-1)$$

where  $g_{lt} = 0.5$  and where the long term prediction gain,  $g_p$ , is calculated by:

$$g_p = \frac{\sum_{n=0}^{L-1} \varepsilon_{pf}(n) \varepsilon_{pf}(n-d_{opt})}{\sum_{n=0}^{L-1} \varepsilon_{pf}(n-d_{opt}) \varepsilon_{pf}(n-d_{opt})}, \quad (5.8.3-2)$$

and where the long-term delay,  $d_{opt}$ , is calculated from  $\varepsilon_p(n)$  by finding the best integer delay around  $d_l = \left( \frac{d(m',0) + d(m',1)}{2} \right)$ . The decoded interpolated integer delay  $d_l$  is searched from  $(d_l - 3)$  to  $(d_l + 3)$  to find the best integer delay for the long-term postfilter. The best integer delay  $d_{opt}$  is computed by maximizing the correlation:

$$R(d_{opt}) = \sum_{n=0}^{L-1} \varepsilon_{pf}(n) \varepsilon_{pf}(n-d_{opt}); \quad (d_l - 3) \leq d_{opt} \leq (d_l + 3). \quad (5.8.3-3)$$

#### 5.8.4 Gain Normalization and Short-Term Postfilter

Compute the temporary signal,  $\hat{s}_s(n)$ , by filtering the long-term postfilter output signal,  $\hat{s}_p(n)$ , through the short-term postfilter,  $H_s(z)$ , given by:

$$H_s(z) = \frac{1}{A_q(\gamma_{p2}^{-1}z)}, \quad (5.8.4-1)$$

where  $\gamma_{p2}$  is found in Table 5.8.1-1.

Then compute the short-term postfilter gain,  $g_s$ , by using the temporary signal,  $\hat{s}_s(n)$ :

$$g_s = \sqrt{\frac{\sum_{n=0}^{L-1} \hat{s}_s^2(n)}{\sum_{n=0}^{L-1} \hat{s}_s^2(n)}}, \quad (5.8.4-2)$$

where  $g_s$  is upper bound limited at 1.0. The signal  $g_s \hat{s}_p(n)$  is then filtered through the short-term postfilter in Equation 5.8.4-1 to produce the final post-filtered speech signal,  $\hat{s}_{pf}(n)$ .

## 5.9 Adaptive post filter for SO 68

The adaptive post filter function improves the perceived speech quality of the decoder output.

### Inputs

The decoder synthesis output signal,  $\hat{s}(n)$

The quantized, interpolated LPC coefficients,  $\hat{A}_q(n)$

1 The quantized, interpolated LSPs,  $\Omega_q(m,k)$ ;  $1 \leq k \leq 10$

2 The interpolated pitch delays,  $d(m')$

### 3 **Output**

4 The post-filtered synthesis signal,  $\hat{s}_{pf}(n)$ .

### 5 **Initialization**

6 All filter memories shall be initialized to zero at start-up.

### 7 **Processing**

8 The decoded speech signal,  $\hat{s}(n)$ , shall be post-filtered by applying the following operations.

9 A reference set of LPCs is first obtained from the decoded speech signal as follows:

$$A_{ref}(k) = \begin{cases} -\frac{\sum_{n=0}^{L-2} \hat{s}(n)\hat{s}(n+1)}{\sum_{n=0}^{L-1} \hat{s}(n)\hat{s}(n)}; & k = 0 \\ 0; & otherwise \end{cases}$$

10  $A_{ref}$  is then converted to a reference LSPs,  $\Omega_{ref}$  as described in Section 4.6.1.3.

11 Two sets of interpolated LSPs,  $\Omega_3$ , and  $\Omega_4$ , are derived from  $\Omega_{ref}$ , and the input interpolated quantized LSPs,  $\Omega_m$  as follows:

$$\Omega_3(i) = \begin{cases} (0.3 + 0.04i)\Omega_{ref}(i) + (0.7 - 0.04i)\Omega_m(i); & 0 \leq i < 5 \\ (0.5)\Omega_{ref}(i) + (0.5)\Omega_m(i); & 5 \leq i < 10 \end{cases}$$

$$\Omega_4(i) = (0.3)\Omega_{ref}(i) + (0.7)\Omega_m(i); \quad 0 \leq i < 10$$

12 These interpolated LSPs are then converted to interpolated LPCs  $A_3$  and  $A_4$  as described in Section 4.6.2.2.

13 The decoded speech signal,  $\hat{s}(n)$ , shall be post-filtered by applying the following operations in the sequence specified:

14 A short term residual filter,  $H_e(z)$

15 A long term filter,  $H_p(z)$

16 Gain normalization,  $g_s$

17 A short term filter,  $H_s(z)$

18 The post filter shall be applied once for each of the three subframes and shall take the form:

$$PF(z) = H_s(z)g_sH_p(z)H_e(z) \quad (5.9-1)$$

1 The post filter residual memory buffer is then updated with the current subframe's residual signal. Each of  
 2 these steps shall be carried out as specified in Sections 5.8.1 to 5.8.5.

3 5.9.1 The short-term residual filter

4 Compute the postfilter residual,  $\epsilon_{pf}(n)$ , by filtering the tilted speech signal,  $\hat{s}_t(n)$ , through  $H\epsilon(z)$  which is  
 5 equal to  $A_3(z)$ .

6 5.9.2 The long-term post filter

7 Generate the long-term post-filtered signal,  $\hat{s}_p(n)$ , by filtering the residual signal,  $\epsilon_{pf}(n)$ , through the long term  
 8 post filter given by:

$$H_p(z) = \begin{cases} 1.0 + g_p g_{lt} z^{-d_{opt}} & ; 0.5 \leq g_p < 1.0, \\ 1.0 + g_{lt} z^{-d_{opt}} & ; 1.0 \leq g_p, \\ 1.0 & ; \text{otherwise,} \end{cases} \quad (5.9.2-1)$$

10 where  $g_{lt} = 0.4$  and where the long term predication gain,  $g_p$ , is calculated by:

$$g_p = \frac{\sum_{n=0}^{L-1} \epsilon_{pf}(n) \epsilon_{pf}(n - d_{opt})}{\sum_{n=0}^{L-1} \epsilon_{pf}(n - d_{opt}) \epsilon_{pf}(n - d_{opt})}, \quad (5.9.2-2)$$

12 and where the long-term delay,  $d_{opt}$ , is calculated from  $\epsilon_{pf}(n)$  by finding the best integer delay  
 13 around  $d_I = \left\lfloor \frac{d(m', 0) + d(m', 1)}{2} \right\rfloor$ . The decoded interpolated integer delay  $d_I$  is searched from  
 14  $(d_I - 3)$  to  $(d_I + 3)$  to find the best integer delay for the long-term postfilter. The best integer delay  $d_{opt}$  is  
 15 computed by maximizing the correlation:

$$R(d_{opt}) = \sum_{n=0}^{L-1} \epsilon_{pf}(n) \epsilon_{pf}(n - d_{opt}); \quad (d_I - 3) \leq d_{opt} \leq (d_I + 3). \quad (5.9.2-3)$$

17 5.9.3 Gain normalization and short-term post filter

18 Compute the temporary signal,  $\hat{s}_s(n)$ , by filtering the long-term postfilter output signal,  $\hat{s}_p(n)$ , through the  
 19 short-term postfilter,  $H_s(z)$ , which is same as  $A_4(z)$ .

20 Then compute the short-term postfilter gain,  $g_s$ , by using the temporary signal,  $\hat{s}_s(n)$ :

$$g_s = \sqrt{\frac{\sum_{n=0}^{L-1} \hat{s}_s^2(n)}{\sum_{n=0}^{L-1} \hat{s}_s^2(n)}}, \quad (5.9.3-1)$$

1 where  $gs$  is upper bound limited at 1.0. The signal  $gs \hat{s}_s(n)$  is then filtered through the short-term postfilter  
 2  $Hs(z)$ , to produce the final post-filtered speech signal,  $\hat{s}_{pf}(n)$ .

3

#### 4 **5.10 Background Noise Estimation (for SO 68)**

5 To allow suppressed Rate 1/8 frames, the output of the adaptive postfilter is used to determine an estimated  
 6 background noise spectrum.

##### 7 **Inputs**

8 The post-filtered synthesis signal,  $\hat{s}_{pf}(n)$

9 The current frame rate, Rate

10 Background noise estimate adaptation factor,  $W_\alpha$

##### 11 **Outputs**

12 None. Only state variables affected.

##### 13 **State Variables**

14 The background noise envelope estimate,  $E_{bgn}$ .

15

##### 16 **Initialization**

17 The following variables shall be set to zero at initialization (frame  $m=0$ ):

18 The overlapped portion of the input buffer (output of the postfilter), {}

19 The following shall be initialized to a startup value other than zero:

20 The channel noise estimate,  $E_{bgn}(0)$

21 The channel energy leaky integrator's memory,  $E_{Nch}(0)$

22

##### 23 **Processing**

24 The background noise spectral estimate is only computed on frames where FER\_FLAG(m) is not set and Rate  
 25 is not equal to Suppressed Rate 1/8. The post-filtered speech signal,  $\hat{s}_{pf}(n)$ , is used to determine the  
 26 background noise spectral estimate at the decoder. Although the frame size of the decoder is 20 ms, the  
 27 background noise spectral estimator uses procedures from the noise suppressor and therefore operates in blocks  
 28 of 10 ms. The following procedures shall be executed two times per 20 ms of decoded speech frame, and the  
 29 current 10ms frame for the background noise estimator shall be denoted  $m$ . Figure 5.10-1 depicts the  
 30 Background Noise Estimator that is described in the following sections.

31

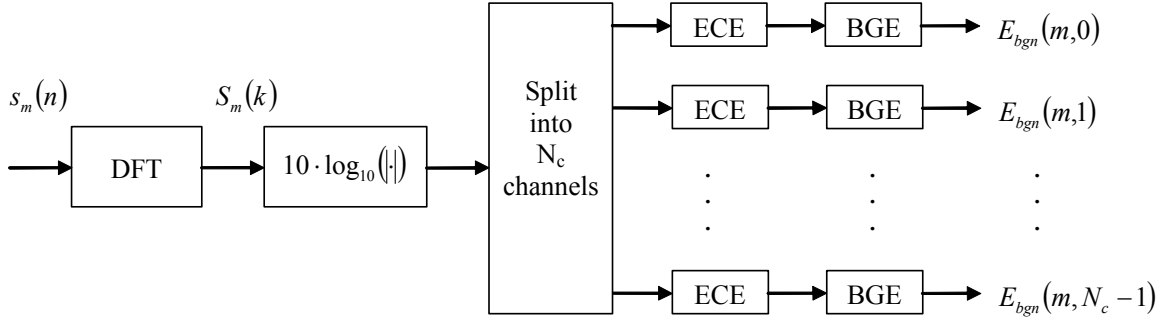

Figure 5.10-1 Background Noise Estimator Block Diagram

5.10.1 Frequency Domain Conversion

The post-filtered signal  $\hat{s}_{pf}(m, n)$  is windowed using a smoothed trapezoid window, in which the first  $D$  samples of the noise estimator's input frame buffer  $s_m(n)$  are obtained by windowing the last  $D$  samples of the previous frame ( $\hat{s}_{pf}(m-1, n)$ ).  $s_m(n)$  is obtained by:

$$s_m(n) = \begin{cases} \hat{s}_{pf}(m-1, L-D+n) \cdot \sin^2(\pi(n+0.5)/2D) & ; 0 \leq n < D, \\ \hat{s}_{pf}(m, n-D) & ; D \leq n < L, \\ \hat{s}_{pf}(m, n-D) \cdot \sin^2(\pi(n-L+D+0.5)/2D) & ; L \leq n < D+L, \\ 0 & ; D+L \leq n < M. \end{cases} \quad (5.10.1-1)$$

where  $m$  is the current frame,  $n$  is the sample index to the buffer  $s_m(n)$ ,  $L = 80$  is the frame length,  $D = 24$  is the overlap (or delay) in samples, and  $M = 128$  is the DFT sequence length. This results in the input buffer containing  $L + D = 104$  samples, and being zero-padded to  $M$  samples.

The transformation of  $s_m(n)$  to the frequency domain is performed using the Discrete Fourier Transform (DFT) to produce  $S_m(k)$  as follows:

$$S_m(k) = \frac{2}{M} \sum_{n=0}^{M-1} s_m(n) e^{-j2\pi nk/M} \quad ; 0 \leq k < M \quad (5.10.1-2)$$

5.10.2 Channel Energy Estimator

Calculate the channel energy estimate  $E_{Nch}(m, i)$  in decibels (dB) for the current frame,  $m$ , as:

$$E_{Nch}(m, i) = \max \left\{ E_{Nmin}, \alpha_w(m) E_{Nch}(m-1, i) + (1 - \alpha_w(m)) \cdot \left( \frac{10}{f_H(i) - f_L(i) + 1} \sum_{k=f_L(i)}^{f_H(i)} \log_{10}(|S_m(k)|^2) + c_m \right) \right\} \quad (5.10.2-1)$$

where  $E_{N\min} = -15dB$  is the minimum allowable channel energy,  $\alpha_w(m)$  is the channel energy smoothing factor (defined below),  $N_c = 16$  is the number of combined channels, and  $f_L(i)$  and  $f_H(i)$  are the  $i$ -th elements of the respective low and high channel combining tables, which are defined in the noise suppressor (Section 4.4.3.2).

The channel energy smoothing factor,  $\alpha_w(m)$ , is defined as:

$$\alpha_w(m) = \begin{cases} 0 & ; m < 3 \\ 0.6 \cdot w_\alpha & ; m \geq 3, rate(m) = 1/8 \\ w_\alpha & ; otherwise \end{cases} \quad (5.10.2-2)$$

and

$$c_m = \begin{cases} 3.52 & ; rate(m) \neq 1/8 \\ 0 & ; otherwise \end{cases} \quad (5.10.2-3)$$

This means that  $\alpha_w(m)$  assumes a value of zero for the first two frames ( $m < 3$ ) and a value of 0.6 times the weight coefficient  $w_\alpha$  for all subsequent frames. This allows the channel energy estimate to be initialized to the unfiltered channel energy of the first frame, and some control over the adaptation via the weight coefficient. The weight coefficient is varied according to:

$$w_\alpha = \begin{cases} 1.0 & ; FER\_FLAG(m) = 1 \\ 1.1 & ; FER\_FLAG(m) \neq 1 \end{cases} \quad (5.10.2-4)$$

### 5.10.3 Background Noise Estimate

The background noise energy estimate  $E_{bgn}$  is updated according to the following:

If the current frame is a rate 1/8 frame,

$$E_{bgn}(m, i) = \beta_1 \cdot E_{Nch}(m-1, i) + (1 - \beta_1) \cdot E_{Nch}(m, i) \quad (5.10.3-1)$$

For all other frame rates:

$$E_{bgn}(m, i) = \begin{cases} E_{Nch}(m, i) & ; E_{Nch}(m, i) < E_{bgn}(m-1, i) \\ E_{bgn}(m-1, i) + \Delta_1 & ; (E_{Nch}(m, i) - E_{bgn}(m-1, i)) > E_{voice} \\ E_{bgn}(m-1, i) + \Delta_2 & ; otherwise \end{cases} \quad (5.10.3-2)$$

1 where  $\Delta_1 = 0.005$ ,  $\Delta_2 = 0.010$   $E_{voice} = 12dB$  ..

2 NOTE: The background update routines are only called when FER\_FLAG(m) is not set and Rate is not set to  
3 Suppressed Rate 1/8.

#### 4 **5.11 Background Noise Estimation (SO 70 in WB mode)**

5 To allow suppressed Rate 1/8 frames, the output of the adaptive postfilter is used to determine an estimated  
6 background noise spectrum.

##### 7 **Inputs**

8 The post-filtered synthesis signal,  $\hat{s}_{pf}(n)$

9 The current frame rate, Rate

10 The current subframe interpolated LPC pcoefficients,  $\dot{A}_q(n)$

11 Background noise estimate adaptation factor,  $w_\alpha$

##### 12 **Outputs**

13 None. Only state variables affected.

##### 14 **State Variables**

15 The background noise envelope estimate,  $\mathbf{E}_{bgn}$ .

16

##### 17 **Initialization**

18 The following variables shall be set to zero at initialization (frame m=0):

19 The overlapped portion of the input buffer (output of the postfilter), {}

20 The following shall be initialized to a startup value other than zero:

21 The channel noise estimate,  $E_{bgn}(0)$

22 The channel energy leaky integrator's memory,  $E_{Nch}(0)$

23

##### 24 **Processing**

25 The background noise spectral estimate is only computed on frames where FER\_FLAG(m) is not set and Rate  
26 is not equal to Suppressed Rate 1/8. The post-filtered speech signal,  $\hat{s}_{pf}(n)$ , is used to determine the  
27 background noise spectral estimate at the decoder. The background noise spectral estimator for SO 70 in WB  
28 mode operates on individual subframes. The following procedures shall be executed for each decoded speech  
29 subframe, and the current subframe for the background noise estimator shall be denoted m. Figure 5.11-1  
30 depicts the Background Noise Estimator that is described in the following sections.

31

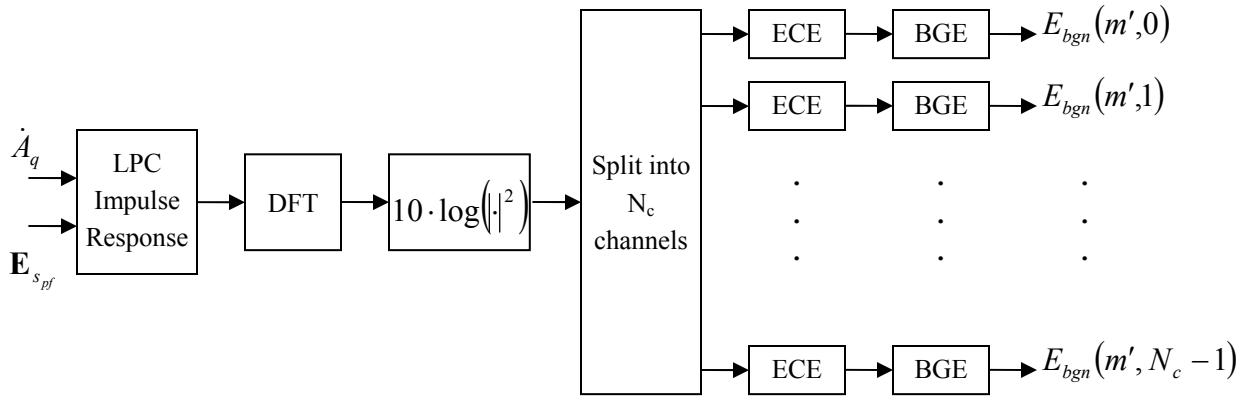

1  
2

**Figure 5.11-1 Background Noise Estimator Block Diagram**

3 5.11.1 Frequency Domain Conversion

4 Before obtaining the frequency domain representation of the current subframe, the impulse response,  $h_{A_q}(n)$ ,  
5 of the interpolated LPC coefficients  $\dot{A}_q$  is computed to  $M = 128$ . Its energy is determined by:

6 
$$E_{h_{A_q}} = \sum_{n=0}^{M-1} h_{A_q}^2(n) \tag{5.11.1-1}$$

7  
8

Also, the energy of the post-filtered signal is computed as follows:

9 
$$E_{s_{pf}} = \sum_{n=0}^{L-1} \hat{s}_{pf}^2(n) \tag{5.11.1-2}$$

10 The frequency domain representation of the current subframe is determined from the impulse response  
11 according to:

12 
$$H_{A_q}(k) = \frac{2}{M} \cdot \sum_{n=0}^{M-1} h_{A_q}(n) \cdot e^{-j2\pi nk/M} \tag{5.11.1-3}$$

13 The energy in  $H_{A_q}(k)$  needs to be adjusted to reflect the energy in the post-filtered signal  $\hat{s}_{pf}(n)$ . The  
14 energy compensating factor is computed as:

15 
$$E_{comp} = \frac{M}{L} \cdot \frac{E_{s_{pf}}}{E_{h_{A_q}}} \tag{5.11.1-4}$$

16 or in dB as:

$$E_{comp\_dB} = 10 \cdot \log_{10} \left( \frac{1}{L} \cdot E_{s_{pf}} \right) - 10 \cdot \log_{10} \left( \frac{1}{M} \cdot E_{h_{aq}} \right) \quad (5.11.1-5)$$

The frequency domain magnitudes are then obtained from:

$$S_{m dB}(k) = 10 \cdot \log_{10} \left( \left| H_{A_q}(k) \right|^2 \right) + E_{comp\_dB} \quad (5.11.1-6)$$

4

### 5.11.2 Channel Energy Estimator

Calculate the channel energy estimate  $E_{Nch}(m', i)$  in decibels (dB) for the current subframe,  $m'$ , as:

$$E_{Nch}(m', i) = \max \left\{ E_{Nmin}, \alpha_w(m') \cdot E_{Nch}(m' - 1, i) + (1 - \alpha_w(m')) \cdot \left( \frac{1}{f_H(i) - f_L(i) + 1} \cdot \sum_{k=f_L(i)}^{f_H(i)} S_{m dB}(k) + c_m \right) \right\} \quad (5.11.2-1)$$

where  $E_{Nmin} = -15dB$  is the minimum allowable channel energy,  $\alpha_w(m')$  is the channel energy smoothing factor (defined below),  $N_c = 16$  is the number of combined channels, and  $f_L(i)$  and  $f_H(i)$  are the  $i$ -th elements of the respective low and high channel combining tables, which are defined in the noise suppressor (Section 4.4.3.2).

The channel energy smoothing factor,  $\alpha_w(m')$ , is defined as:

$$\alpha_w(m') = \begin{cases} 0 & ; m < 3 \\ 0.8 \cdot w_\alpha & ; m \geq 3, rate(m) = 1/8 \\ w_\alpha & ; otherwise \end{cases} \quad (5.11.2-2)$$

and

$$c_m = \begin{cases} 3.52 & ; rate(m) \neq 1/8 \\ 0 & ; otherwise \end{cases} \quad (5.11.2-3)$$

17

This means that  $\alpha_w(m')$  assumes a value of zero for the first two frames ( $m < 3$ ) and a value of 0.8 times the weight coefficient  $w_\alpha$  for all subsequent frames. This allows the channel energy estimate to be initialized to the unfiltered channel energy of the first frame, and some control over the adaptation via the weight coefficient. The weight coefficient is varied according to:

$$w_\alpha = \begin{cases} 1.0 & ; FER\_FLAG(m) = 1 \\ 1.1 & ; FER\_FLAG(m) \neq 1 \end{cases} \quad (5.11.2-4)$$

22

1

## 2 5.11.3 Background Noise Estimate

3 The background noise energy estimate  $E_{bgn}$  is updated according to the following:

4 If the current frame is a rate 1/8 frame,

5 
$$E_{bgn}(m', i) = \beta_1 \cdot E_{Nch}(m' - 1, i) + (1 - \beta_1) \cdot E_{Nch}(m', i) \quad (5.11.3-1)$$

6 For all other frame rates:

7 
$$E_{bgn}(m', i) = \begin{cases} E_{Nch}(m', i) & ; E_{Nch}(m', i) < E_{bgn}(m' - 1, i) \\ E_{bgn}(m' - 1, i) + \Delta_1 & ; (E_{Nch}(m', i) - E_{bgn}(m' - 1, i)) > E_{voice} \\ E_{bgn}(m' - 1, i) + \Delta_2 & ; otherwise \end{cases} \quad (5.11.3-2)$$

8

9 where  $\Delta_1 = 0.005$ ,  $\Delta_2 = 0.010$ , and  $E_{voice} = 12dB$ .10 NOTE: The background update routines are only called when FER\_FLAG(m) is not set and Rate is not set to  
11 Suppressed Rate 1/8.

12

13

## 14 5.11.4 Suppressed Eighth Rate Likelihood predictor

15 In some systems the rate=0 may not be defined or practical to use. In these systems suppressed eighth rate  
16 frames are tagged as erased frames (rate=0xE) and there is no distinction between an error frame (erased) or an  
17 eighth rate frame that was suppressed. In order to distinguish between these two cases labeled as erasures, the  
18 background energy estimator determines the likelihood of having a suppressed eighth rate frame come after the  
19 current frame and sets a flag accordingly. When an rate=0xE frame is received, this information is used to  
20 determine how to handle the erasure (see Section 5.1.3).21 The *dtx\_likely\_flag* is set according to the energy in the current subframe as compared to the estimated  
22 background noise energy using:

23

24 
$$dtx\_likely\_flag = \begin{cases} true & ; energy\{\hat{s}_{pf}\} < energy\{E_{bgn}\} \\ false & ; otherwise \end{cases} \quad (5.11.4-1)$$

25

26 **5.12 Generation of High band signal for 16 KHz decoding for SO 70**

27 The High band excitation is derived from the lowband excitation as described in Section 4.8.13.

1 This excitation is LPC filtered using the dequantized high-band LPC (obtained after dequantization and LSP to  
 2 LPC conversion).

3 The frame gains and the subframe gains are then applied to the synthesized high-band speech signal.

4 When FER\_FLAG(m) is set, the previous frame's high-band LSPs and gains are used to generate the high-band  
 5 signal for the erased frame.

6 For eighth-rate frames, the high-band signal is using a sort of a Discontinuous Transmission scheme for the  
 7 high-band. The previous frame's (the encoder ensures that there is atleast 1 half-rate frame unvoiced frame)  
 8 high-band LSP and gain parameters are used to synthesize the eighth-rate frame in addition to the low-band  
 9 excitaiton.

10 **5.13 Decoding of Synthesis Filterbank for 16 KHz decoding for SO 70**

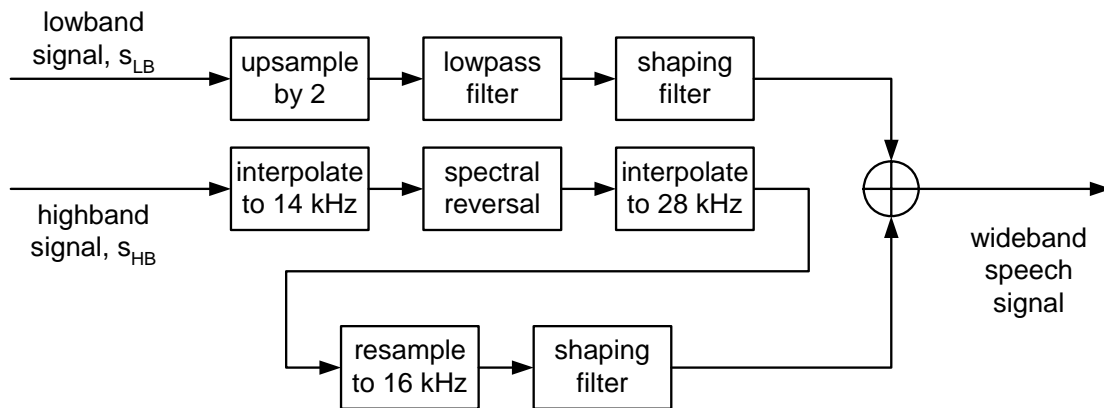

11

12 **Figure 5.13-1 Synthesis Filterbank for SO 70 16 KHz Decoding**

13

14

15 **5.13.1 Processing the lowband signal,  $s_{LB}$**

16 **5.13.1.1 Upsample by and lowpass filter**

17 The upsample-by-2 and the low pass filters can be realized as a polyphase implementation. The wideband  
 18 speech signal  $s_{WB}$  is first separate into odd time indexed and even time indexed subsequences. These  
 19 subsequences are filtered by two 16<sup>th</sup> order FIR filters and the outputs of these filters are added to derive the  
 lowband signal,  $s_{LB}$ .

20 **5.13.1.2 Shaping Filter**

21 The upsampled lowband signal, is then shaped using a 1<sup>st</sup> order pole-zero filter to yield the 16 KHz lowband  
 22 signal,  $s_{LB,16KHz}$ .

1 5.13.2 Processing the high band signal

2 5.13.2.1 Interpolation to 14 kHz

3 The 7 KHz signal  $s_{HB}$  is first upsampled to 14 KHz,  $s_{14}[n]$ , through the use of a 3-section polyphase  
4 implementation.

5 The even components of  $s_{14}[n]$ , for  $n=0, 2, 4, 6$  etc are obtained by filtering  $s_{HB}[n/2]$  through an allpass filter  
6 whose transfer function is given by

$$7 \quad H_{up2,0} = \left( \frac{a_{up2,0,0} + z^{-1}}{1 + a_{up2,0,0}z^{-1}} \right) \left( \frac{a_{up2,0,1} + z^{-1}}{1 + a_{up2,0,1}z^{-1}} \right) \left( \frac{a_{up2,0,2} + z^{-1}}{1 + a_{up2,0,2}z^{-1}} \right)$$

8 And the odd components of  $s_{14}[n]$ , for  $n=1, 3, 5, 7$  etc are obtained by filtering  $s_{HB}[n/2]$  through an allpass filter  
9 whose transfer function is given by

$$10 \quad H_{up2,1} = \left( \frac{a_{up2,1,0} + z^{-1}}{1 + a_{up2,1,0}z^{-1}} \right) \left( \frac{a_{up2,1,1} + z^{-1}}{1 + a_{up2,1,1}z^{-1}} \right) \left( \frac{a_{up2,1,2} + z^{-1}}{1 + a_{up2,1,2}z^{-1}} \right)$$

11 5.13.2.2 Spectral reversal

12 The spectrum of  $\hat{s}_{14}$  is reversed by multiplying the odd components by -1 to yield a signal  $s_{14}$ .

13 5.13.2.3 Interpolation to 28 kHz

14 The 14 KHz signal  $s_{HB}$  is then upsampled to 28,  $s_{28}[n]$ , through the use of a 3-section polyphase  
15 implementation.

16 The even components of  $s_{28}[n]$ , for  $n=0, 2, 4, 6$  etc are obtained by filtering  $s_{HB}[n/2]$  through an allpass filter  
17 whose transfer function is given by

$$18 \quad H_{up2,0} = \left( \frac{a_{up3,0,0} + z^{-1}}{1 + a_{up3,0,0}z^{-1}} \right) \left( \frac{a_{up3,0,1} + z^{-1}}{1 + a_{up3,0,1}z^{-1}} \right) \left( \frac{a_{up3,0,2} + z^{-1}}{1 + a_{up3,0,2}z^{-1}} \right)$$

19 And the odd components of  $s_{28}[n]$ , for  $n=1, 3, 5, 7$  etc are obtained by filtering  $s_{HB}[n/2]$  through an allpass filter  
20 whose transfer function is given by

$$21 \quad H_{up2,1} = \left( \frac{a_{up2,1,0} + z^{-1}}{1 + a_{up2,1,0}z^{-1}} \right) \left( \frac{a_{up2,1,1} + z^{-1}}{1 + a_{up2,1,1}z^{-1}} \right) \left( \frac{a_{up2,1,2} + z^{-1}}{1 + a_{up2,1,2}z^{-1}} \right)$$

22 5.13.2.4 Resampling to 16 KHz

23  $s_{28}[n]$  is resampled by a factor of 4/7 to obtain a 16 KHz signal,  $s_{16}[n]$ . This is obtained using a polyphase  
24 interpolation according to

$$25 \quad s_{28}(7n + j) = \sum_{k=0}^9 h_{32to28}(j, k) s_{32}(8n + j); \quad n = 0, 1, 2, \dots, 320/8 - 1, j = 0, 1, 2, \dots, 6$$

26 5.13.3 Combining the lowband and highband

27 The lowband signal,  $s_{LB}$ , and the highband signal,  $s_{HB}$ , are combined to give the final 16 KHz wideband output  
28 as

1  $s_{16}(n) = s_{LB}(n) + 0.9s_{HB}(n)$

## 6 TTY/TDD EXTENSION FOR SO 3

### 6.1 Introduction

This section provides an option to reliably transport the TTY/TDD 45.45 bps and 50 bps Baudot code, making digital wireless technology accessible to TTY/TDD users. This section is separated into two major components. Section 6.3 describes the new interface between the encoder and the decoder for transporting the TTY information. Section 6.3.4 is a description of the TTY/TDD software simulation of this section, and is offered only as a recommendation for implementation. However, in the event of ambiguous or contradictory information, the software simulation shall be used to resolve any conflicts.

This section is an extension of the previous version of the TTY/TDD extension for EVRC [S7b]. It extends the previous version by adding the 50 bps Baudot functionality, but is capable with interoperating with [S7b] when used at 45.45 bps. See Section 6.3.3.2 for details regarding interoperability with [S7b].

This section uses the following verbal forms: “Shall” and “shall not” identify requirements to be followed strictly to conform to the standard and from which no deviation is permitted. “Should” and “should not” indicate that one of several possibilities is recommended as particularly suitable, without mentioning or excluding others; that a certain course of action is preferred but not necessarily required; or that (in the negative form) a certain possibility or course of action is discouraged but not prohibited. “May” and “need not” indicate a course of action permissible within the limits of the standard. “Can” and “cannot” are used for statements of possibility and capability, whether material, physical, or causal.

### 6.2 Overview

The following sections provide a method for reliably transporting the 45.45 bps and 50 bps Baudot code in the audio path, making digital wireless telephony accessible to TTY/TDD users. The following extension is robust to frame and bit errors and is completely interoperable with the pre-existing EVRC [S7a] speech-coding standard. The solution supports voice carryover/hearing carryover (VCO/HCO). VCO allows a TTY/TDD user to switch between receiving TTY and talking into the phone. Similarly, HCO allows a user to switch between transmitting TTY characters and picking up the phone to listen. When Baudot tones are not present, the vocoder operates as usual, there is no modification or added delay to the voice path when speech is present.

The TTY/TDD audio solution transports Baudot signals through the vocoder by detecting the characters, and their baud rate, that are being transmitted by the TTY/TDD in the encoder and conveying those characters to the decoder. Because one Baudot character spans at least 7 speech processing frames, the character being transmitted shall be sent a minimum of 6 times to the decoder, allowing the decoder to correctly regenerate the character despite frame errors and random bit errors in the speech packet.

The TTY characters are concealed in the speech packet in a way that interoperates with legacy vocoders that have not been modified for TTY. This is made possible because, when Baudot tones are present, the TTY information replaces the pitch lag bits for the adaptive codebook (ACB) and the ACB gain is set to zero so that an unmodified decoder ignores the TTY information. The rest of the bits in the speech packet contain information for an unmodified decoder to reconstruct the Baudot signal with the fixed codebook and the linear prediction (LPC) filter at least as well as if the encoder was not modified. Furthermore, the encoder shall disable noise suppression, and the rate shall be set to full rate when the Baudot tones are present. This further enhances the system’s performance when a modified encoder is interoperating with an unmodified decoder.

1 A decoder modified with this extension maintains a history buffer to monitor the ACB gain and pitch lag in the  
2 speech packets. When the decoder detects that the ACB gain has been set to zero, and the pitch lag contains  
3 information consistent with TTY, the decoder stops decoding speech and begins regenerating the Baudot tones.  
4 When the decoder stops detecting TTY information, it resumes processing speech.

5 When Baudot tones are not present, the modified vocoder operates on speech in exactly the same way as the  
6 unmodified vocoder. The TTY processing does not add any additional delay to the speech path.

### 7 **6.3 TTY/TDD Extension**

8 The TTY processing in the encoder shall process the received PCM one frame at a time and label each frame as  
9 NON\_TTY, or as TTY\_SILENCE, or as a TTY character. The vocoder will be in one of two states:  
10 TTY\_MODE or NON\_TTY\_MODE. In the absence of Baudot tones, the encoder and decoder shall be in the  
11 NON\_TTY\_MODE, and the encoder and decoder shall process the frame as speech. When Baudot tones are  
12 present, the encoder and decoder shall enter TTY\_MODE and process the TTY information as described  
13 below.

14 There shall exist a mechanism to disable the TTY/TDD extension in the vocoder, reverting the vocoder to its  
15 unmodified state.

#### 16 6.3.1 TTY Onset Procedure

17 The TTY Onset Procedure describes the process by which the vocoder shall transition from the speech mode to  
18 the TTY mode.

##### 19 6.3.1.1 Encoder TTY Onset Procedure

20 When the TTY encoder processing initially detects that Baudot tones are present, the encoder shall label each  
21 frame as TTY\_SILENCE until it buffers enough frames to detect the character being sent. The TTY\_SILENCE  
22 message shall be sent to the decoder according to the method described below. Because of the delay caused by  
23 the buffering in the encoder and decoder to detect TTY characters, it is necessary to alert the decoder to mute  
24 its output when Baudot tones are first detected. This prevents the Baudot tones from getting through the speech  
25 path before the TTY decoder processing is able to detect the TTY characters and regenerate the tones. The  
26 TTY\_SILENCE message shall be sent to the decoder within 2 frames after the PCM containing the Baudot  
27 tones initially enters the encoder. However, in order to reduce the risk of false alarms, the TTY encoder may  
28 delay sending the TTY\_SILENCE message for the very first character in a call. The TTY\_SILENCE message  
29 shall be sent for a minimum of 4 frames and shall continue to be sent until a TTY character is detected, or until  
30 a NON\_TTY frame is detected.

##### 31 6.3.1.2 Decoder TTY Onset Procedure

32 When the decoder is in NON\_TTY\_MODE, the packet shall be decoded in the usual manner for speech.  
33 Because there are no bits in the packet to switch the decoder's state, the decoder shall infer the presence of TTY  
34 information from the ACB gain and pitch information. The decoder shall recognize when TTY\_SILENCE  
35 messages are being sent in the packets and transition from NON\_TTY\_MODE to TTY\_MODE before the  
36 decoder's speech path reconstructs a TTY character from the audio information in the speech packets. When  
37 the decoder makes the transition to TTY\_MODE, it shall mute its output until it detects TTY characters or until  
38 it transitions back to NON\_TTY\_MODE. Refer to the implementation recommendation in Section 6.3.4 for an  
39 example of the TTY decoder processing.

### 1 6.3.1.3 TTY\_MODE PROCESSING

2 The format of the Baudot code can be found in ITU-T Recommendation V.18 [S10]. The Baudot code is a  
3 carrierless, binary FSK signaling scheme. A 1400 Hz. tone is used to signal a logical “1” and an 1800 Hz. tone  
4 is used to signal a logical “0”. A TTY bit has a duration of  $22 \pm 0.4$  ms for 45.45 baud and  $20 \pm 0.4$  ms for 50  
5 baud. A character consists of 1 start bit, 5 data bits, and 1.5 – 2 stop bits. When a character is not being  
6 transmitted, silence, or a noisy equivalent, is transmitted. Hence, a TTY character spans a minimum of 7  
7 speech processing frames. When the TTY encoder processing detects a character, it shall send the character, its  
8 baud rate, and its header (see Section 6.3.2) for a description of the header) to the decoder over a minimum of 6  
9 consecutive frames and a maximum of 16 frames. Because channel impairments cause frame errors and bit  
10 errors, the decoder may not receive all of the packets sent by the encoder. The decoder shall use the  
11 redundancy to correct any corrupted TTY information. Once the decoder recognizes the TTY character being  
12 sent, the decoder’s TTY repeater shall regenerate the Baudot tones corresponding to that character.

13 At call startup, the encoder processing may initialize its baud rate to either 45.45 baud or 50 baud. It is  
14 recommended that the default baud rate be set to the predominant baud rate of the region. Because the encoder  
15 may require several characters to determine the correct baud rate, it should be expected that the baud rate may  
16 change 3-7 characters into the TTY call.

### 17 6.3.1.4 TTY\_SILENCE Processing

18 In order to reduce the average data rate of a TTY call, the TTY processing shall be capable of transmitting 1/8  
19 rate packets to the decoder when the encoder is processing the silence periods between characters. Since no  
20 TTY information is in the 1/8 packet, the decoder shall infer TTY\_SILENCE from an 1/8 rate packet when it is  
21 in TTY\_MODE. The TTY\_SILENCE message may also be sent to the decoder using a full rate frame, as  
22 described in Section 6.3.2. When setting the rate to accommodate the TTY information, care shall be taken so  
23 that a full rate frame is not immediately followed by an 1/8 rate frame. This is an illegal rate transition  
24 according to [S7a], and will force an unmodified decoder to declare a frame erasure.

### 25 6.3.2 TTY Header, Baud Rate, and Character Format

26 The TTY information put into the speech packet contains header character, and baud rate information. When  
27 the encoder is transmitting a TTY character, the header shall contain a sequence number to distinguish that  
28 character from its preceding and following neighbors. The same header, character, and baud rate information  
29 shall be transmitted for each instance of a character for a minimum of 6 frames and a maximum of 16 frames.  
30 The header shall cycle through its range of valid values, one value for each instance of a character. The header  
31 and character field shall be assigned a value to correspond to the TTY\_SILENCE message. TTY\_SILENCE  
32 may also be conveyed by 1/8 rate packets (see Section 6.3.1.4).

33 The rate bit shall specify the baud rate to be regenerated by the decoder. The rate bit shall be set to ‘0’ to  
34 denote 45.45 baud and ‘1’ to denote 50 baud. During the TTY\_SILENCE message, the baud rate bit shall be set  
35 to its last transmitted value. In the case where the baud rate has not yet been determined, the default startup  
36 baud rate shall be used. The encoder processing may initialize its baud rate to either 45.45 baud or 50 baud.

1  
2

**Table 6.3.2-1 TTY Header and Character Fields**

Description	Range		
	Header (2 bits)	Character (5 bits)	Baud Rate (1 bit)
Reserved	0	0 – 31	0-1
TTY Character	1 – 2	0 – 31	0-1
TTY_SILENCE	3	4	0-1
Reserved	3	0 – 3, 5 – 31	0-1

3  
4  
5  
6  
7

The combinations of valid values for the TTY header, character, and baud rate fields are specified in Table 6.3.2-1. Note that the value for TTY\_SILENCE corresponds to the index for the maximum pitch value allowed by the vocoder. All unused values are reserved for future use and shall be considered as invalid values for the purposes of this annex.

8 **6.3.3 Transporting the TTY Information in the Speech Packet.**

9 In full rate and half rate, there are 7 bits per frame assigned to the pitch lag. In full rate, the last bit of the  
10 speech packet, Bit 171, is reserved by the speech coder. This bit plus the 7 bits assigned to the pitch lag shall  
11 be used to convey TTY information from the encoder to the decoder using full rate frames. Half rate packets  
12 may also be used for conveying TTY information. Because half rate packets have only 7 bits available, i.e., the  
13 7 pitch lag bits, half rate frames shall contain the TTY header and TTY character information only and the  
14 decoder shall use its last valid baud rate to regenerate TTY characters. In order to improve interoperability  
15 between a modified encoder and an unmodified decoder, it is recommended to transport the TTY information in  
16 a full rate packet; however, a modified decoder shall be capable of detecting TTY information in both full rate  
17 and half rate packets.

18 The TTY information replaces the pitch lag bits and the reserved Bit 171. The ACB gain shall be set to zero for  
19 each subframe in packets containing TTY information. Bit 171 shall be used to convey the baud rate  
20 information and the 7 pitch lag bits shall be used to convey the TTY header and character information. The 5  
21 least significant bits of the pitch bits shall be used for the 5-bit Baudot code. Two remaining pitch bits shall be  
22 used for the TTY header information. The TTY information is assigned to the pitch lag bits according to

PITCH LAG BIT ASSIGNMENT						
MSB						LSB
6	5	4	3	2	1	0
TTY HEADER		5 BIT BAUDOT CODE				
MSB	LSB	MSB				LSB
1	0	4	3	2	1	0

1 Table 6.3.3-1.

2

PITCH LAG BIT ASSIGNMENT						
MSB						LSB
6	5	4	3	2	1	0
TTY HEADER		5 BIT BAUDOT CODE				
MSB	LSB	MSB				LSB
1	0	4	3	2	1	0

3

**Table 6.3.3-1 TTY Header and Character Bit Assignment**

4

#### 5 6.3.3.1 Half Rate TTY Mode

6 In the case where the encoder and decoder are both modified for TTY, it is possible to reduce the average data  
 7 rate by using half rate packets to transport TTY information. Half rate packets should only be used to transport  
 8 TTY information during Dim & Burst signaling, or when it is determined that both the near-end and far-end  
 9 vocoders are TTY capable. When the near-end (far-end) decoder recognizes that the far-end (near-end)  
 10 encoder is sending TTY information, the near-end (far-end) encoder may be notified by the near-end (far-end)  
 11 decoder to send TTY information in half rate packets. When the near-end (far-end) decoder receives a  
 12 NON\_TTY packet, the near-end (far-end) encoder should exit half rate TTY mode. This preserves  
 13 interoperability in the event of a hard handoff from a modified vocoder to an unmodified vocoder. Because  
 14 half rate packets do not convey the baud rate, the vocoder should return to full rate for at least 4 characters after  
 15 a change in baud rate before returning to half rate TTY mode, whenever possible. In Dim & Burst signaling,  
 16 for example, it may be more desirable to stay in half rate TTY mode to complete the signaling message rather  
 17 than go to full rate to convey a baud rate change.

#### 18 6.3.3.2 Interoperability with 45.45 Baud-Only TTY Extensions

19 Previous TTY extensions support 45.45 bps Baudot code only. This extension supports both 45.45 baud and  
 20 50 baud by using an additional bit to convey the baud rate. Note, the other 7 bits used for the character  
 21 information and header are the same as the 45.45 baud-only TTY extensions.

22 Because the baud rate uses a bit in the encoded speech packet that was not previously used for TTY, some level  
 23 of interoperability is achieved (See Table 6.3.3.2-1). When a 45.45 baud decoder is receiving 50 baud TTY  
 24 packets, it will regenerate the characters at 45.45 baud. In this case, the regenerator may fall behind and drop  
 25 characters because it is regenerating characters at a slower rate than the encoder is sending them.

1

**Table 6.3.3.2-1 Baud Rate Interoperability Matrix**

	45.45 baud-only decoder	45.45 and 50 baud decoder
45.45 baud-only encoder	Compatible	EITHER 45.45 OR 50 BAUD WILL BE REGENERATED BY THE DECODER, DEPENDING ON THE VALUE OF THE BAUD RATE BIT SET BY THE ENCODER.
45.45 and 50 baud encoder	BAUD RATE IS IGNORED AND DECODER ALWAYS REGENERATES 45.45 BAUD.	Compatible

2 In the case where the encoder is 45.45 baud-only and the decoder is capable of regenerating either 45.45 or 50  
 3 baud, the 2 header bits and the 5 TTY character bits are the same, so the decoder is able to decode these bits  
 4 correctly. The baud rate bit, however, has no meaning to the 45.45 baud-only encoder, so it will be set  
 5 randomly, depending on the implementation, and the baud rate used by the decoder will depend on the value of  
 6 the baud rate bit.

7 In order for 45.45 baud-only implementations to interoperate with this extension, it is recommended that the  
 8 45.45 baud-only encoder implementations set the reserved Bit 171 to zero so that the baud rate bit is set to  
 9 45.45 baud.

10 **6.3.3.3 Reflected Baudot Tones**

11 It is possible for the signal generated by the TTY solution to reflect back to the near-end TTY detector, either  
 12 on the network side or the mobile side. Possible sources of the reflected signal are crosstalk, impedance  
 13 mismatch, or hybrid echo. To prevent the detector from detecting Baudot tones, that are not intentionally  
 14 originated by the TTY device, the input PCM shall be muted, before being processed by the near-end encoder,  
 15 whenever Baudot tones are being regenerated. This requirement applies to both the network and mobiles. Note,  
 16 the sample solution described in Section 6.3.4 does not contain a mechanism for blocking reflected Baudot  
 17 tones.

18 **6.3.4 TTY/TDD Processing Recommendation**

19 The following describes the software simulation of this annex. It is intended as a recommendation for  
 20 implementation only and is not required to satisfy compliance with this annex. However, the software shall be  
 21 used to resolve ambiguous or incomplete statements that may exist in the sections above. The TTY/TDD  
 22 processing is divided into 2 major components, encoder processing and decoder processing. The TTY encoder  
 23 process detects the presence of Baudot tones and decodes the TTY character being transmitted. It then conveys  
 24 that information to the decoder. The TTY decoder processing shall detect the presence of TTY information and  
 25 regenerate the Baudot tones corresponding to that character. Refer to Figure 6.3.4-1 for a block diagram of the  
 26 TTY processing.

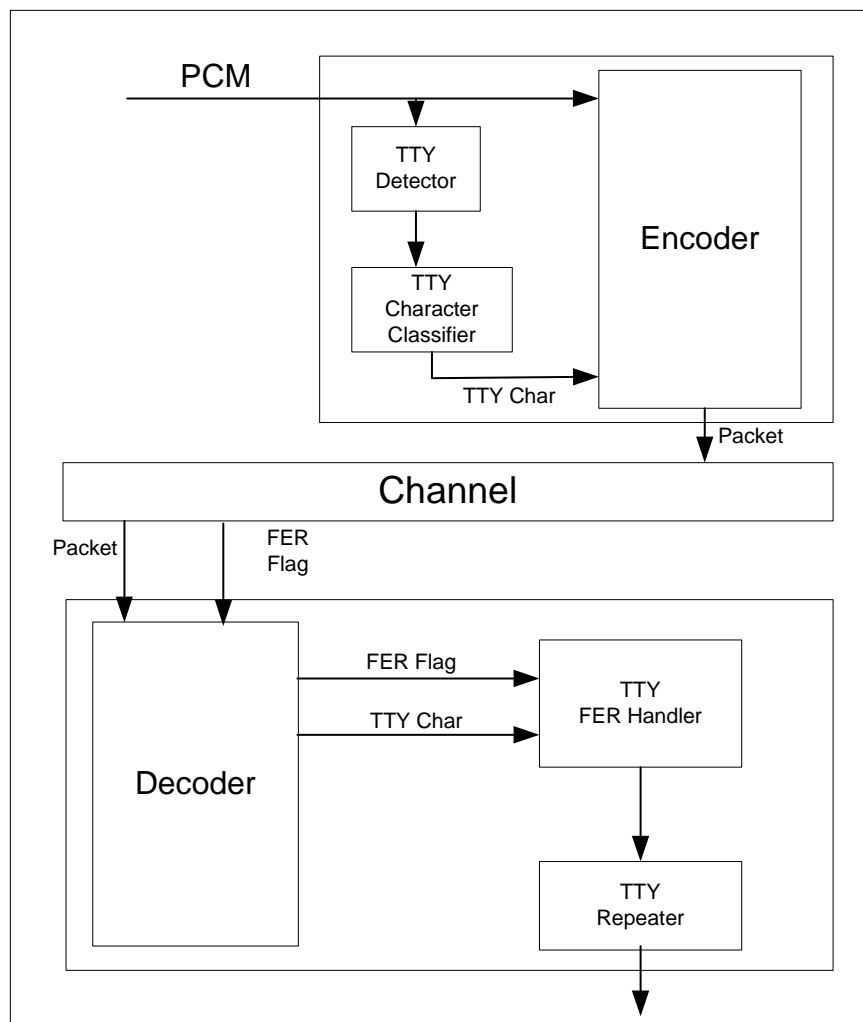

1  
2  
3  
4  
5  
6  
7  
8  
9  
10  
11  
12  
13  
14  
15  
16

**Figure 6.3.4-1 TTY/TDD Processing Block Diagram**

### 6.3.5 TTY Encoder Processing

The TTY encoder processing takes the larger task of detecting TTY characters and divides it into a series of smaller tasks, creating different levels of detection. It is through this divide and conquer approach that the `tty_enc()` routine has low complexity in the absence of Baudot tones.

The first level of detection is to divide the 160 samples in the speech frame into 10 blocks of 16 samples. These blocks are called detection intervals, or dits. Each dit is classified as `NON_TTY`, `LOGIC_0`, or `LOGIC_1`.

The next level of detection is to determine if there are enough `LOGIC_0` or `LOGIC_1` dits in a row to form a TTY bit. The transition from a “0” bit to a “1” bit or the detection of two consecutive “0” bits signals the onset of a character and the `TTY_SILENCE` message is sent to the decoder. The `TTY_SILENCE` message shall continue to be sent until a TTY character is detected, or until a `NON_TTY` frame is detected. When enough bits are detected to form a character, the rate of the character is determined and the TTY character information is sent to the decoder.

1 6.3.5.1 TTY Encoder Inputs

- 2 • TTY character information from the previous frame (header, TTY character, and baud rate).  
3 • 160 PCM samples from the output of the high pass filter.

4 6.3.5.2 Dit Classification

5 The 160 samples from the high pass filter's output are converted into 10 dits. For every block of 16 samples, it  
6 computes the spectral energy at the mark and space frequencies using a 16-point DFT at 1400 Hz and 1800 Hz  
7 with a rectangular window. The ratio of the maximum energy between the mark and space energy and the total  
8 energy is compared to a threshold; i.e.,

9 
$$\frac{\max(\text{mark\_energy}, \text{space\_energy})}{\text{total\_energy}} > \text{THRESH}$$

10 If that threshold is exceeded, the dit is labeled as either a mark or a space, whichever one has the greater  
11 energy. If the threshold is not met, the dit is labeled as NON\_TTY.

12 6.3.5.3 Dits to Bits

13 The dits are used to form a TTY bit. Dits are classified as LOGIC\_0, LOGIC\_1, or UNKNOWN. A nominal  
14 bit consists of 11 dits for 45.45 baud and 10 dits for 50 baud. A bit is not required to have a continuous run of  
15 LOGIC\_0's or LOGIC\_1's in order to be detected. Spurious UNKNOWN detections are permitted, up to a  
16 threshold.

17 A TTY bit is searched by looking at the dits within a variable-length sliding window. The window varies in  
18 length from 8 dits to 13 dits. The number of LOGIC\_0's, LOGIC\_1's, and UNKNOWN dit detections are  
19 counted in the window. The dits in the search window must meet the following criteria in order to detect a  
20 TTY bit:

- 21 • Minimum of 6 LOGIC\_0 (LOGIC\_1) dits  
22 • Maximum of 2 LOGIC\_1 (LOGIC\_0) dits  
23 • Maximum of 5 UNKNOWN dits

24 Heuristics are also applied so that the sliding window is centered over the TTY bit being detected. If all of the  
25 thresholds are met, a "0" ("1") TTY bit is declared, and the overall length of the bit and the number of bad dits  
26 within the window are recorded. If the dits in the search window do not meet the criteria for a TTY bit, a gap  
27 between TTY bits is declared and the gap is recorded. The window is slid by one dit and the search is repeated.

28 The length of the search window is allowed to vary. The length is adjusted depending on the previous  
29 character's baud rate, and where the mark/space transitions occur.

30 Two history buffers are maintained to record the detected TTY bits and gaps. The array `tty_bit_hist[ ]`  
31 maintains a history of the bits that are detected and `tty_bit_len_hist[ ]` stores the lengths, in dits, of the gaps and  
32 TTY bits that are detected. Both arrays are 9 elements long, there is one element for the start bit, five for the  
33 data bits, one for the stop bit, and one for the memory bit, the bit before the start bit, as depicted in Table  
34 6.3.5.3-1. The last element in the array is used to record partially detected TTY bits.

Table 6.3.5.3-1 TTY Bit History Buffer

0	1	2	3	4	5	6	7	8
Memory Bit	Start Bit	LSB Data 0	Data 1	Data 2	Data 3	MSB Data 4	Stop Bit	Next Bit

When a TTY bit or a gap is detected, its value is recorded in `tty_bit_hist[ ]` and its length is stored in `tty_bit_len_hist[ ]`. The length is used by `get_tty_char( )` to threshold the length of a candidate character, and by `tty_rate( )` to determine if a detected character is 45.45 baud or 50 baud. Since the length of the memory bit is irrelevant, `tty_bit_len_hist[0]` is used to count the number of NON\_TTY and TTY\_SILENCE dits that were detected within the TTY bits.

Because the speech frames may not coincide with the boundaries of the TTY bits, it is possible that a bit may straddle two speech frames. It is possible, therefore, that the sliding window may contain only a partial bit within a frame. These partial detections are recorded in element 8 of the TTY bit history buffers, labeled “Next Bit” in Table 6.3.5.3-1.

#### 6.3.5.4 TTY Character Classification

The routine `get_tty_char( )` checks if the detected bits form a TTY character. The following conditions must be met in order for a character to be declared.

- The bit preceding the start bit must not be a “0”.
- The start bit must be a “0”
- The stop bit must be a “1”
- The length of the candidate character, in dits, must be within a maximum and minimum threshold.
- The number of bad dit detections within the character must be within a threshold.

If all of the conditions are met, a character is declared.

Once a character is found, the character information and its header are sent to the decoder a minimum of 6 frames and a maximum of 16 frames. The constant `FRAMING_HANGOVER` dictates the maximum number of times the information for the same character is sent. If a new character is framed before `FRAMING_HANGOVER` is reached, the information for the old character is terminated and the new information is sent to the decoder.

#### 6.3.5.5 TTY Baud Rate Determination

After a character has been detected, `tty_rate( )` determines the baud rate of the character by counting the length, in dits, of the start bit and the five data bits. The length of the stop bit is not used because its length is too variable.

A character with a length of 63 dits or greater is declared 45.45 baud, otherwise it is declared 50 baud. A hangover of three characters is maintained before `tty_rate( )` will switch from one baud rate to the other. That is to say, if the baud rate changes in the middle of a call, three consecutive characters must be detected at the new baud rate in order for `tty_rate( )` to declare the new baud rate.

#### 6.3.5.6 TTY State Machine

The routine `get_tty_state( )` is responsible for changing the state of the TTY encoder processing. There are 3 states, `NON_TTY_MODE`, `TTY_ONSET`, and `TTY_MODE`. `Get_tty_state( )` is responsible for determining `NON_TTY_MODE` and `TTY_ONSET`.

1 Changing TTY state from NON\_TTY\_MODE to TTY\_ONSET requires that a “0” bit is followed by a “1” bit.  
 2 This rule requires the presence of both the space tone and the mark tone and for the tones to be the correct  
 3 duration. This test must be met in order to declare TTY\_ONSET for the first time.

4 NON\_TTY\_MODE is declared by get\_tty\_state( ) whenever a non-TTY bit is detected or when a “0” bit  
 5 occupies the bit preceding the start bit.

6 6.3.6 TTY/TDD Decoder Processing

7 The TTY decoder processing must recognize when TTY/TDD information is in the packet, recover from  
 8 channel impairments to decode the TTY character being sent, and regenerate the Baudot tones corresponding to  
 9 that character.

10 When the decoder is in NON\_TTY\_MODE, the packet is decoded in the usual manner for speech. When the  
 11 decoder makes the transition to TTY\_MODE, it mutes its output until it receives TTY character information or  
 12 until it transitions back to NON\_TTY\_MODE.

13 6.3.6.1 TTY Decoder Inputs

- 14 • TTY Information (header, TTY character, baud rate).
- 15 • Bad frame indicator

16 6.3.6.2 Decoding the TTY/TDD Information

17 The task of detecting the presence of TTY information, recovering from frame and bit errors, and decoding the  
 18 TTY character is performed in tty\_dec( ). If the routine detects that TTY information is being sent, the tty\_dec(  
 19 ) flag is set to non-zero and the PCM buffer is filled with the appropriate Baudot tones. If TTY is not detected,  
 20 the flag is set to zero and the PCM buffer is returned unmodified.

21

22 **Table 6.3.6.2-1 tty\_dec( ) History Buffer**

Frame:	0	1	2	3	4	5	6	7	8	9	10
Description :	Lookahead									Current Frame	Lookback

23

24 The routine labels each frame as NON\_TTY, TTY\_SILENCE, FER, or a TTY character, and maintains a  
 25 history buffer of these classifications for 11 frames: 9 frames of lookahead, 1 current frame, and 1 frame of  
 26 lookback (see Table 6.3.6.2-1). The most recent packet enters the buffer at location 0, but the decision for the  
 27 current frame is based on the contents of element 9. The buffer is updated at the end of each frame, shifting its  
 28 contents to the right by one. The buffer is initialized to NON\_TTY.

29 At the start of each frame, the most recent information is sanity checked to see if it is consistent with TTY  
 30 information. If the frame erasure flag is set, the frame is labeled FER, otherwise the TTY/TDD information is  
 31 checked to see if the header and TTY character fields fall within the allowed range of values. If all of the tests  
 32 pass, Frame 0 is labeled with the TTY character in the history buffer.

33 The TTY decoder processing can reliably regenerate the TTY characters despite channel impairments because  
 34 the character information is transmitted a minimum of 6 times from the encoder. Errors are corrected by a

1 voting process. The current frame and nine frames of lookahead are used to determine the correct TTY header,  
2 character, and baud rate. Errors are replaced with the winner of the voting process.

3 Voting is conducted under the following conditions:

- 4 • Any time the current frame is labeled as FER.
- 5 • Every time the current frame contains information for the start of a new character. Because a new  
6 character must contain a minimum of 6 frames of the same information, a vote is taken to verify that  
7 the information is present before it will generate the tones for that character. Once a character wins  
8 the vote, any frame errors, bit errors, or other inconsistencies are corrected in the frame window where  
9 the character information is expected, i.e. the current frame and the adjacent frames of lookahead will  
10 contain the same header and character information.
- 11 • Any time the current frame contains TTY\_SILENCE or a TTY character, and the frame of lookback  
12 contains NON\_TTY. This makes it harder for the decoder to erroneously go into TTY\_MODE, thus  
13 preventing false alarms when speech is present.

14 In the normal course of TTY transmissions, TTY\_SILENCE messages are sent first, followed by the TTY  
15 character information. When 3 TTY\_SILENCE messages are received in a window of 5 frames, the decoder's  
16 output is muted until a NON\_TTY frame is received or until the voting results in a TTY character to be  
17 regenerated. If a new character is detected, it will only be regenerated if it was preceded by TTY\_SILENCE.  
18 If it is not, the character information is ignored and the decoder returns to NON\_TTY mode. This is done to  
19 prevent false alarms from packets that look like TTY packets but are really speech packets with the ACB gain  
20 coincidentally set to zero.

21 Once `tty_dec()` makes its decision on the current frame, `tty_dec()` calls `tty_gen()` to generate the appropriate  
22 PCM samples.

### 23 6.3.6.3 Baudot Generator

24 Once the current frame is labeled by `tty_dec()`, `tty_gen()` is called to fill the PCM buffer with the appropriate  
25 Baudot tones. In the case of NON\_TTY, the PCM buffer is returned unmodified. In the case of  
26 TTY\_SILENCE, the PCM is muted.

27 Generating TTY characters is more involved because one character spans many frames, so `tty_gen()` must  
28 generate the Baudot tones one subframe at a time. When a TTY character needs to be regenerated, `tty_gen()`  
29 puts a subframe's worth of samples in the PCM buffer. It keeps track of which bit it is in the middle of  
30 generating and the number of samples left to generate for that bit, so that the next time it is called, it can pick up  
31 where it left off. Once `tty_gen()` begins to generate a character, it will generate the entire character before it  
32 will generate the next character. This is done so that the repeater will only generate valid TTY characters.

33 There exists logic in `tty_gen()` to detect when the next character arrives before the current one is finished. If  
34 the next character arrives before the current one can be regenerated, a minimum of 1 stop bit is generated.

35 There exists a provision in the ITU-T Recommendation V.18 [S10] for the TTY/TDD device to extend its stop  
36 bit in order to prevent a TTY/TDD device from detecting its own echo. This routine will extend the stop bit a  
37 maximum of 300 ms if a TTY character is followed by silence. If a new character arrives before 300 ms has  
38 elapsed, the extended stop bit is terminated and the new character is generated immediately.

39 The tones themselves are generated by `tone_gen()`. Before `tty_gen()` returns, it updates the decoder's  
40 lookback field in the TTY history buffer with the information corresponding to the last samples generated. For  
41 example, if `tty_gen()` finished generating a character in the middle of the subframe and started generating  
42 silence, the lookback field is updated with TTY\_SILENCE.

1 6.3.6.4 Tone Generator

2 The routine `tone_gen( )` is a sine wave generator. Given a frequency and the number of samples, it will  
3 generate the PCM samples by using a 2 tap marginally stable IIR filter. The filter implements the trigonometric  
4 identity:

5 
$$\cos(k\omega) = 2 \cdot \cos(\omega) \cdot \cos((k-1)\omega) - \cos((k-2)\omega)$$

6 It is a zero excitation filter, using only its past 2 samples and the cosine of the frequency to be generated, to  
7 produce the next sample.

1

2 **7 EVRC-B DATA CAPABILITIES**3 **7.1 EVRC-B data capabilities**

4 EVRC-B provides the capability for passing data by replacing the speech allocated bits by general user data  
5 bits. This capability is called in-band or in-bitstream data. In this document, TTY/TDD Baudot Code (45.45  
6 baud and 50 baud) and DTMF are the only data payloads that are defined and supported by EVRC-B.

7 In-band TTY/TDD Baudot Code is mandatory. All EVRC-B implementations shall include in-band TTY/TDD  
8 capability. However, in-band DTMF is not always mandatory. Depending upon applications such as wireless  
9 local loop (fixed wireless) or mobility, in-band DTMF can be optional. In any case, in-band and out-of-band  
10 DTMF shall not be transmitted simultaneously.

11 For mobility applications, in-band DTMF signaling shall not be used.

12 For fixed wireless (also known as wireless local loop) applications, sending DTMF in the forward link is  
13 common (e.g., answering machine access). In order to guarantee that in-band DTMF can be decoded correctly  
14 in both forward and reverse links, implementing the in-band DTMF decoder is mandatory in both directions  
15 (forward and reverse), whereas implementing the in-band DTMF encoder is optional.

16 In-band data is transported with Rate 1/2 packet with data.

17 The TTY/TDD and DTMF features define their own error recovery schemes. The decoder, however, is capable  
18 of automatically detecting the in-band data by decoding the packet. No out-of-band signaling is required to  
19 send in-band data from the encoder to the decoder.

20 When the encoder sends in-band data to the decoder, the data is packed in Rate 1/2 frames and they contain a  
21 unique bit pattern that can be identified by the decoder to indicate that the packet contains data. The decoder  
22 then reads the header bits to determine which type of data is in the frame and calls the appropriate algorithm to  
23 regenerate the signal at the decoder's output, or to send the data to an appropriate application.

24 The bit allocation for Rate 1/2 data frames is summarized in Table 7.1-1.

25

26

**Table 7.1-1 Bit allocation for rate 1/2 data frames**

<b># of bits</b>	<b>Rate 1/2 data frame</b>
3	Data Header
70	Data Block
7	Illegal Lag Codeword

27

28 For in-band data formats, a codeword is put in the packet that is considered illegal for speech frames. A packet  
29 is identified as containing data if these fields are set to the values below. The illegal codeword for each of the  
30 in-band data formats are in Table 7.1-2.

31

1

**Table 7.1-2** Illegal codeword value

Codeword	Rate 1/2 data
Illegal Lag Codeword	0x78

2

3 Whereas the illegal codeword identifies the packet as containing data, the Data Header is a 3-bit field, which  
 4 identifies the data format and payload. Table 7.1-3 contains a description of the Data Header field for Rate 1/2  
 5 packets.

6

**Table 7.1-3** Data header description

Data Header value	Rate 1/2 (bits 2 to 4)
0	Reserved
1	Data
2	TTY/TDD
3	DTMF
4	Reserved
5 to 7	Reserved

7

8 **7.2 TTY/TDD payload format**

9 The TTY/TDD payload shall be transported using the Rate 1/2 packet data format only. Rate 1 data formats  
 10 shall not be used for this application. For TTY/TDD payloads, the Data Header field shall be set to 2 (see Table  
 11 7.1-3) and the first 8 bits of the data field shall correspond to the TTY Type field. The Baudot code is currently  
 12 the only TTY Type supported by this standard. Table 7.2-1 summarizes the valid values for the TTY Type  
 13 field.

14

**Table 7.2-1** TTY Type field

TTY Type	Description
0	Reserved
1	Baudot Code
2 to 255	Reserved

15

16 **7.3 Baudot code payload**

17 Payloads for TTY/TDD Baudot codes at 45.45 baud and 50 baud are defined for EVRC-B. For transmitting the  
 18 Baudot code, the Data Field shall be set to 2 and TTY Type shall be set to 1. For Baudot, the bits in the Rate  
 19 1/2 packet are defined as in Table 7.3-1.

1

**Table 7.3-1 Rate 1/2 packet for TTY/TDD baudot code payload**

<b># of bits</b>	<b>Field</b>	<b>Value</b>
3	Data Header	2
8	TTY Type	1
8	TTY Header	See Table 7.5.1-1
16	TTY Character	See Table 7.5.1-2
16	TTY Rate	See Table 7.5.1-3
22	Reserved	N/A
7	Illegal Codeword	0x78

2

**7.4 DTMF payload format**

The DTMF payload shall be transported using the Rate 1/2 packet data format only. Rate 1 data formats shall not be used for this application. Table 7.4-1 shows a Rate 1/2 packet with the format for a DTMF payload. The Data Header field shall be set to 3 (see Table 7.1-3) and the first 16 bits of the data field shall correspond to a 16-bit signed value DTMF digit, as specified in Table 7.4-2.

**Table 7.4-1 Rate 1/2 packet with DTMF payload**

# of bits	Field	Value
3	Data Header	3
16	DTMF Digit	See Table 7.4-2
54	Reserved	N/A
7	Illegal Codeword	0x78

**Table 7.4-2 DTMF data values**

Data field	DTMF signal
1	1
2	2
3	4
5	5
6	6
7	7
8	8
9	9
10	0
11	*
12	#
13	A
14	B
15	C
16	D
-1	No signal detected

## 1 7.5 TTY/TDD operation

2 The following feature provides a method for reliably transporting the 45.45 bps and 50 bps Baudot code in the  
3 EVRC-B, making digital wireless telephony accessible to TTY/TDD users. The feature supports voice  
4 carryover/hearing carryover (VCO/HCO). VCO allows a TTY/TDD user to switch between receiving TTY and  
5 talking into the phone. Similarly, HCO allows a user to switch between transmitting TTY characters and  
6 picking up the phone to listen. When Baudot tones are not present, the vocoder operates as usual; there is no  
7 modification or added delay to the voice path when speech is present.

8 The Baudot code is specified in ITU-T Recommendation V.18 [S10]. The Baudot code is a carrierless, binary  
9 FSK signaling scheme. A 1400 Hz tone is used to signal a logical "1" and a 1800 Hz tone is used to signal a  
10 logical "0". A 45.45 bps TTY bit has a duration of  $22 \text{ ms} \pm 0.4$  and a 50 bps bit has a duration of  $20 \text{ ms} \pm 0.4$ ,  
11 and a character consists of 1 start bit, 5 data bits, and 1.5 to 2 stop bits. When a character is not being  
12 transmitted, silence, or a noisy equivalent, is transmitted. Hence, a TTY character spans a minimum of 6 speech  
13 processing frames. When the TTY encoder processing detects a character, it sends the character and its header  
14 (see Section 7.5.1 for a description of the header) to the decoder over a minimum of 6 consecutive frames and a  
15 maximum of 16 frames. Because of channel impairments, the decoder may not receive all of the packets sent by  
16 the encoder because of frame erasures and random bit errors. The decoder uses the redundancy to correct any  
17 corrupted TTY information. Once the decoder recognizes the TTY character being sent, the decoder's TTY  
18 repeater regenerates the Baudot tones corresponding to that character. The TTY processing in the encoder  
19 processes the received PCM input one frame at a time and labels each frame as either NON\_TTY,  
20 TTY\_ONSET, or as a TTY character. The vocoder is in one of two states, TTY\_MODE or  
21 NON\_TTY\_MODE. In the absence of Baudot tones, the encoder and decoder are in the NON\_TTY\_MODE  
22 and the encoder and decoder process the frame as speech. When Baudot tones are present, the encoder and  
23 decoder enter TTY\_MODE and process the TTY information as described in the following subsections. When  
24 the vocoder stops detecting TTY information, it resumes processing speech.

25 It is recommended that a mechanism exist to disable the TTY/TDD feature in the vocoder.

26 Figure 7.5-1 depicts the TTY/TDD processing block diagram.

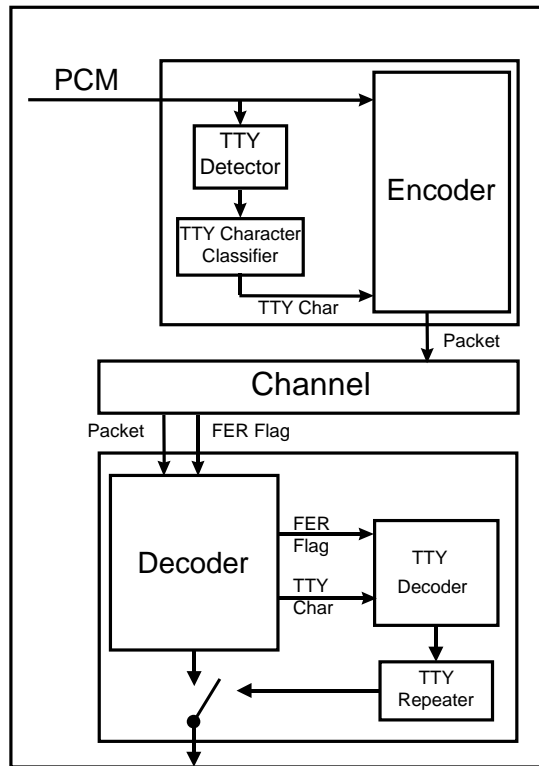

1

2

**Figure 7.5-1 TTY/TDD processing block diagram**

3

7.5.1 TTY header and character format

4

The TTY information passed from the encoder to the decoder contains a header, character information, and the baud rate. When the encoder is transmitting a TTY character, the header contains a sequence number to distinguish that character from the characters immediately before and after. The same TTY information is transmitted for each instance of a character for a minimum of 6 frames and a maximum of 16 frames. The header cycles through its range of valid values, one value for each instance of a character. During the TTY\_ONSET state, the encoder sends the decoder a TTY\_SILENCE message in the header and character field. The TTY header uses 2 bits in an 8-bit field (see Table 7.5.1-1). The TTY character uses 5 bits in a 16-bit field (see Table 7.5.1-2). The TTY baud rate uses 1 bit in a 16-bit field (see Table 7.5.1-3).

11

1 **Table 7.5.1-1 Range of values for TTY/TDD Baudot header field**

Range	Description
0	TTY_SILENCE
1 to 3	TTY Counter
4 to 255	Reserved

2  
3 **Table 7.5.1-2 Range of values for TTY/TDD Baudot character field**

Range	Description
4	TTY_SILENCE (when TTY Header = 0)
0 to 31	TTY Character
32 to 65535	Reserved

4  
5 **Table 7.5.1-3 Range of values for TTY/TDD baud rate field**

Range	Description
0	45.45 baud
1	50 baud
2 to 65535	Reserved

6  
7 **7.5.2 TTY encoder processing**

8 The TTY encoder processing takes the larger task of detecting TTY characters and divides it into a series of  
9 smaller tasks, creating different levels of detection. It is through this divide and conquer approach that the  
10 `tty_enc()` routine has low complexity in the absence of Baudot tones.

11 The first level of detection is to divide the 160 samples in the speech frame into 10 blocks of 16 samples. These  
12 blocks are called detection intervals, or dits. Each dit is classified as `NON_TTY`, `LOGIC_0`, or `LOGIC_1`.

13 The next level of detection is to determine if there are enough `LOGIC_0` or `LOGIC_1` dits in a row to form a  
14 TTY bit. The transition from a “0” bit to a “1” bit is used to determine the onset of a TTY character and the  
15 `TTY_SILENCE` message is sent to the decoder. The `TTY_SILENCE` message shall continue to be sent until a  
16 TTY character is detected, or until a `NON_TTY` frame is detected. When enough bits are detected to form a  
17 character, the rate of the character is determined and the TTY character information is sent to the decoder.

18 **7.5.2.1 TTY encoder inputs**

19 TTY character information from the previous frame (header, TTY character, and baud rate)

20 160 PCM samples from the output of the high pass filter

## 1 7.5.2.2 Dit classification

2 The 160 samples from the high pass filter's output are converted into 10 dits. For every block of 16 samples, it  
 3 computes the spectral energy at the mark and space frequencies using a 16-point DFT at 1400 Hz and 1800 Hz  
 4 with a rectangular window. The ratio of the maximum energy between the mark and space energy and the total  
 5 energy is compared to a threshold; i.e.:

$$6 \quad \frac{\max(\text{mark\_energy}, \text{space\_energy})}{\text{total\_energy}} > \text{THRESH}$$

7 If that threshold is exceeded, the dit is labeled as either a mark or a space, whichever one has the greater  
 8 energy. If the threshold is not met, the dit is labeled as NON\_TTY.

9 A second threshold is applied to the total energy of the dit. If the total energy is less than the threshold, the dit  
 10 is classified as NON\_TTY. This minimum energy threshold prevents the TTY detector from being overly  
 11 sensitive to low level tones that may have been unintentionally reflected back into the TTY detector. The  
 12 threshold is set at approximately -50 dBm.

## 13 7.5.2.3 Dits to bits

14 The dits are used to form a TTY bit. Dits are classified as LOGIC\_0, LOGIC\_1, or UNKNOWN. A nominal bit  
 15 consists of 11 dits for 45.45 baud and 10 dits for 50 baud. A bit is not required to have a continuous run of  
 16 LOGIC\_0's or LOGIC\_1's in order to be detected. Spurious UNKNOWN detections are permitted, up to a  
 17 threshold.

18 A TTY bit is searched by looking at the dits within a variable length sliding window. The window varies in  
 19 length from 8 dits to 13 dits. The number of LOGIC\_0's, LOGIC\_1's, and UNKNOWN dit detections are  
 20 counted in the window. The dits in the search window must meet the following criteria in order to detect a TTY  
 21 bit:

22 Minimum of 6 LOGIC\_0 (LOGIC\_1) dits

23 Maximum of 2 LOGIC\_1 (LOGIC\_0) dits

24 Maximum of 5 UNKNOWN dits

25 Heuristics are also applied so that the sliding window is centered over the TTY bit being detected. If all of the  
 26 thresholds are met, a "0" ("1") TTY bit is declared, and the overall length of the bit and the number of bad dits  
 27 within the window are recorded. If the dits in the search window do not meet the criteria for a TTY bit, a gap  
 28 between TTY bits is declared and the gap is recorded. The window is slid by one dit and the search is repeated.

29 The length of the search window is allowed to vary. The length is adjusted depending on the previous  
 30 character's baud rate, and where the mark/space transitions occur.

31 Two history buffers are maintained to record the detected TTY bits and gaps. The array `tty_bit_hist[]` maintains  
 32 a history of the bits that are detected and `tty_bit_len_hist[]` stores the lengths, in dits, of the gaps and TTY bits  
 33 that are detected. Both arrays are 9 elements long; there is one element for the start bit, five for the data bits,  
 34 one for the stop bit, and one for the memory bit, the bit before the start bit, as depicted in Table 7.5.2.3-1. The  
 35 last element in the array is used to record partially detected TTY bits.

36

Table 7.5.2.3-1 TTY bit history buffer

0	1	2	3	4	5	6	7	8
Memory Bit	Start Bit	LSB Data 0	Data 1	Data 2	Data 3	MSB Data 4	Stop Bit	Next Bit

When a TTY bit or a gap is detected, its value is recorded in `tty_bit_hist[]` and its length is stored in `tty_bit_len_hist[]`. The length is used by `get_tty_char()` to threshold the length of a candidate character, and by `tty_rate()` to determine if a detected character is 45.45 baud or 50 baud. Since the length of the memory bit is irrelevant, `tty_bit_len_hist[0]` is used to count the number of NON\_TTY and TTY\_SILENCE dits that were detected within the TTY bits.

Because the speech frames may not coincide with the boundaries of the TTY bits, it is possible that a bit may straddle two speech frames. It is possible, therefore, that the sliding window may contain only a partial bit within a frame. These partial detections are recorded in element 8 of the TTY bit history buffers, labeled “Next Bit” in Table 7.5.2.3-1.

#### 7.5.2.4 TTY character classification

The routine `get_tty_char()` checks if the detected bits form a TTY character. The following conditions must be met in order for a character to be declared:

The bit preceding the start bit must not be a “0”.

The start bit must be a “0”.

The stop bit must be a “1”.

The length of the candidate character, in dits, must be within a maximum and minimum threshold.

The number of bad dit detections within the character must be within a threshold.

If all of the conditions are met, a character is declared.

Once a character is found, the character information and its header are sent to the decoder a minimum of 6 frames and a maximum of 16 frames. The constant `FRAMING_HANGOVER` dictates the maximum number of times the information for the same character is sent. If a new character is framed before `FRAMING_HANGOVER` is reached, the information for the old character is terminated and the new information is sent to the decoder.

#### 7.5.2.5 TTY baud rate determination

After a character has been detected, `tty_rate()` determines the baud rate of the character by counting the length, in dits, of the start bit and the five data bits. The length of the stop bit is not used because its length is too variable.

A character with a length of 63 dits or greater is declared 45.45 baud, otherwise, it is declared 50 baud. A hangover of three characters is maintained before `tty_rate()` will switch from one baud rate to the other. That is to say, if the baud rate changes in the middle of a call, three consecutive characters must be detected at the new baud rate in order for `tty_rate()` to declare the new baud rate.

1 7.5.2.6 TTY state machine

2 The routine `get_tty_state()` is responsible for changing the state of the TTY encoder processing. There are 3  
 3 states, `NON_TTY_MODE`, `TTY_ONSET`, and `TTY_MODE`. `Get_tty_state()` is responsible for determining  
 4 `NON_TTY_MODE` and `TTY_ONSET`.

5 Changing TTY state from `NON_TTY_MODE` to `TTY_ONSET` requires that a “0” bit is followed by a “1” bit.  
 6 This rule requires the presence of both the space tone and the mark tone and for the tones to be the correct  
 7 duration. This test must be met in order to declare `TTY_ONSET` for the first time.

8 `NON_TTY_MODE` is declared by `get_tty_state()` whenever a non-TTY bit is detected or when a “0” bit  
 9 occupies the bit preceding the start bit.

10 7.5.3 TTY/TDD decoder processing

11 The TTY decoder processing must recognize when TTY/TDD information is in the packet, recover from  
 12 channel impairments to decode the TTY character being sent, and regenerate the Baudot tones corresponding to  
 13 that character.

14 When the decoder is in `NON_TTY_MODE`, the packet is decoded in the usual manner for speech. When the  
 15 decoder makes the transition to `TTY_MODE`, it mutes its output until it receives TTY character information or  
 16 until it transitions back to `NON_TTY_MODE`.

17 7.5.3.1 TTY decoder inputs

18 TTY information (header, TTY character, baud rate)

19 Bad frame indicator

20 7.5.3.2 Decoding the TTY/TDD information

21 The task of detecting the presence of TTY information, recovering from frame and bit errors, and decoding the  
 22 TTY character is performed in `tty_dec()`. If the routine detects that TTY information is being sent, the `tty_dec()`  
 23 flag is set to nonzero and the PCM buffer is filled with the appropriate Baudot tones. If TTY is not detected, the  
 24 flag is set to zero and the PCM buffer is returned unmodified.

25 The routine labels each frame as `NON_TTY`, `TTY_SILENCE`, `FER`, or a TTY character, and maintains a  
 26 history buffer of these classifications for 11 frames: 9 frames of lookahead, 1 current frame, and 1 frame of  
 27 lookback (see Table 7.5.3.2-1). The most recent packet enters the buffer at location 0, but the decision for the  
 28 current frame is based on the contents of element 9. The buffer is updated at the end of each frame, shifting its  
 29 contents to the right by one. The buffer is initialized to `NON_TTY`.

30

31

**Table 7.5.3.2-1 `tty_dec()` history buffer**

Frame	0	1	2	3	4	5	6	7	8	9	10
Description	Lookahead									Current Frame	Lookback

32 At the start of each frame, the most recent information is sanity checked to see if it is consistent with TTY  
 33 information. If the frame erasure flag is set, the frame is labeled FER, otherwise, the TTY/TDD information is

1 checked to see if the header and TTY character fields fall within the allowed range of values. If all of the tests  
2 pass, Frame 0 is labeled with the TTY character in the history buffer.

3 The TTY decoder processing can reliably regenerate the TTY characters despite channel impairments because  
4 the character information is transmitted a minimum of 6 times from the encoder. Errors are corrected by a  
5 voting process. The current frame and 9 frames of lookahead are used to determine the correct TTY header,  
6 character, and baud rate. Errors are replaced with the winner of the voting process.

7 Voting is conducted under the following conditions:

8 Any time the current frame is labeled as FER.

9 Every time the current frame contains information for the start of a new character. Because a new  
10 character must contain a minimum of 6 frames of the same information, a vote is taken to verify  
11 that the information is present before it will generate the tones for that character. Once a character  
12 wins the vote, any frame errors, bit errors, or other inconsistencies are corrected in the frame  
13 window where the character information is expected, i.e., the current frame and the adjacent  
14 frames of lookahead will contain the same header and character information.

15 Any time the current frame contains TTY\_SILENCE or a TTY character, and the frame of lookback  
16 contains NON\_TTY. This makes it harder for the decoder to erroneously go into TTY\_MODE,  
17 thus preventing false alarms when speech is present.

18 Once `tty_dec()` makes its decision on the current frame, `tty_dec()` calls `tty_gen()` to generate the  
19 appropriate PCM samples.

### 20 7.5.3.3 Baudot generator

21 Once the current frame is labeled by `tty_dec()`, `tty_gen()` is called to fill the PCM buffer with the appropriate  
22 Baudot tones. In the case of NON\_TTY, the PCM buffer is returned unmodified. In the case of  
23 TTY\_SILENCE, the PCM is muted.

24 Generating TTY characters is more involved because one character spans many frames, so `tty_gen()` must  
25 generate the Baudot tones one subframe at a time. When a TTY character needs to be regenerated, `tty_gen()`  
26 puts a subframe's worth of samples in the PCM buffer. It keeps track of which bit it is in the middle of  
27 generating and the number of samples left to generate for that bit, so that the next time it is called, it can pick up  
28 where it left off. Once `tty_gen()` begins to generate a character, it will generate the entire character before it will  
29 generate the next character. This is done so that the repeater will only generate valid TTY characters.

30 There exists logic in `tty_gen()` to detect when the next character arrives before the current one is finished. If the  
31 next character arrives before the current one can be regenerated, the bit duration is reduced by 4 samples and a  
32 minimum of 1 stop bit is generated. Otherwise, nominal bit lengths are generated, i.e., 22 ms bits for 45.45  
33 baud and 20 ms bits for 50 baud, and a minimum of 1.5 stop bits is generated for 45.45 baud, and a minimum  
34 of 1.75 stop bits is generated for 50 baud.

35 There exists a provision in the ITU-T Recommendation V.18 [S10] for the TTY/TDD device to extend its stop  
36 bit in order to prevent a TTY/TDD device from detecting its own echo. This routine will extend the stop bit a  
37 maximum of 300 ms if a TTY character is followed by silence. If a new character arrives before 300 ms has  
38 elapsed, the extended stop bit is terminated and the new character is generated immediately.

39 The tones themselves are generated by `tone_gen()`. Before `tty_gen()` returns, it updates the decoder's lookback  
40 field in the TTY history buffer with the information corresponding to the last samples generated. For example,  
41 if `tty_gen()` finished generating a character in the middle of the subframe and started generating silence, the  
42 lookback field is updated with TTY\_SILENCE.

7.5.3.4 Tone generator

The routine tone\_gen() is a sine wave generator. Given a frequency and the number of samples, it will generate the PCM samples by using a 2 tap marginally stable IIR filter. The filter implements the trigonometric identity:

$$\cos(k\omega) = 2 \cdot \cos(\omega) \cdot \cos((k-1)\omega) - \cos((k-2)\omega)$$

It is a zero excitation filter, using only its past 2 samples and the cosine of the frequency to be generated, to produce the next sample.

7.6 DTMF

7.6.1 DTMF detector

The DTMF (Dual Tone Multiple Frequency) detector detects the presence and the information content of incoming DTMF tone signals. Its row and its column frequency, listed in Table 7.6.1-1, uniquely identify each key on the keypad. It outputs a 16-bit value associated with each of the 16 possible DTMF tone combinations.

**NOTE** A row and a column tone is associated with each digit.

**Table 7.6.1-1 Touch-tone telephone keypad**

		Column frequency group			
		1209 Hz	1336 Hz	1477 Hz	1633 Hz
Row frequency group	697 Hz	1	2	3	A
	770 Hz	4	5	6	B
	852 Hz	7	8	9	C
	941 Hz	*	0	#	D

7.6.1.1 Description of the DTMF detector

The DTMF detector consists of three main functions:

AGC – Normalizes the input frame.

Goertzel – Performs spectral analysis at the 8 frequencies and at the second harmonic of the column frequencies using an 80 point Goertzel algorithm. The Goertzel algorithm provides an efficient means of calculating the DFT energy at a specific frequency (see Oppenheim and Schaffer, *Digital Signal Processing*, Prentice-Hall). In addition, a 160 point Goertzel algorithm is used at the first and fourth row frequency in order to satisfy the requirements found in Bellcore document *GR-506-CORE LSSGR: Signaling and Analog Interfaces*, Issue 1, June 1996.

Check – Checks the spectral energies to determine if a valid DTMF tone is detected.

7.6.1.2 Input

Pointer to 16-bit linear time series for current 20 msec. frame and 10 msec. look-ahead.

1 7.6.1.3 Output

2 16-bit valid DTMF tone digit if a tone is detected or 0xffff to indicate no DTMF present.

3

4

5

6

7

8

9

10

11

12

13

14

15

16

17

18

19

20

21

22

23

24

25

26

27

28

29

30

31

32



## 1 8 CHANGE HISTORY FOR EVRC

### 2 Introduction

3 The following is catalog of changes that were adopted for the EVRC ANSI (EVRC-A) standard [S8].

### 5 Bug Fixes and Sanity Checks

#### 6 Bottom Guard for Offset

- 7 • Text Changes:       Modify Sections 4.5.6.2.1-3
- 8 • Floating Point C Sim: cshift.c
- 9 • Fixed Point C Sim:   cshift.c
- 10 • Test Vector:       ansi\_offset.pcm

11 The offset computed in cshiftframe() is used in maxeloc() to index elements in the array residual[]. Under  
12 certain circumstances, offset value causes maxeloc() to access elements below residual[0]. A fix constrains the  
13 offset so that maxeloc() does not attempt to access residual[] below &residual[0].

#### 14 All-Zeros Packet

- 15 • Text:               Create Section 1.4.3
- 16 • Floating Point C Sim: fer.c
- 17 • Fixed Point C Sim:   fer.c
- 18 • Test Vector:       ansi\_zeros.pkt

19 Detect of all-zeros full rate and half rate packets. If such a packet is detected, the frame is erased. This avoids  
20 clicks and pops in the decoded speech.

#### 21 All-Ones Packet

- 22 • Text:               Modify Section 1.4.2
- 23 • Floating Point C Sim: d\_globs.c, d\_globs.h, decode.c, fer.c
- 24 • Fixed Point C Sim:   d\_globs.c, d\_rate\_1.c, fer.c
- 25 • Test Vector:       ansi\_ones.pkt

26 Mute after more than 2 all-ones Rate 1/8 packets are received. This fixed an end-of-call buzz problem.

#### 27 Gaussian Noise Fix

- 28 • Text:               No change
- 29 • Floating Point C Sim: decode.c
- 30 • Fixed Point C Sim:   d\_fer.c
- 31 • Test Vector:       ansi\_fer.pkt

32 This fix has the seed value of the erasure noise random number generator initialized only once at the beginning  
33 of a set of consecutive erasure frames. Otherwise, the seed is reloaded for each sub frame generating a "noise

### 3GPP2 C.S0014-C ver 1.0

1 envelope" that repeats with the period of a subframe length. It sounds vaguely like the noise from a bug's  
2 wings, hence, it has been referred to as the "wing" sound.

#### 3 Delta Delay Check

- 4 • Text: New Section 5.1.3
- 5 • Floating Point C Sim: decode.c
- 6 • Fixed Point C Sim: d\_no\_fer.c
- 7 • Test Vector: ansi\_ddelay.pkt

8 This change increases the integrity checks on the incoming frame to make sure the DDELAY value would yield  
9 a valid pitch value. In some cases, out of range pitch values would drive the adaptive post filter berserk.

#### 10 Bandwidth Expansion of Erasure LSPs

- 11 • Text: Modify Section 5.2.1
- 12 • Floating Point C Sim: fer.c
- 13 • Fixed Point C Sim: d\_fer.c , d\_rate\_1.c
- 14 • Test Vector: ansi\_fer.pkt

15 This improvement addresses the "buzz" sound. In some cases, valid frames may generate LSP/LPC values that  
16 cause the synthesis filter to go unstable. Typically, these values are used for only one frame, but if these frames  
17 are followed by a series of erasure frames, the old LSP/LPC values are "reused" causing "rail-to-rail"  
18 oscillations of the synthesis filter. This fix interpolates the old LSP values, eventually causing the LSP to go  
19 "full spread", which yields LPC coefficients that make the synthesis filter to go to unity gain, passing the  
20 erasure noise only.

#### 21 **TTY Changes**

22 This section is to serve as a reminder that the TTY library for EVRC [S7a] has been changed to support both  
23 45.45 baud and 50 baud Baudot code. The library is based on the TTY library, which uses the 40-bit DSP math  
24 library. The major differences are:

- 25 1. Supports both 45.45 baud and 50 baud Baudot code.
- 26 2. Makes the half-duplex solution mandatory for mitigating the effects of echo, on both the mobile and the  
27 infrastructure.
- 28 3. Applies a minimum input energy threshold to the input signal so that very low level tones (below -50  
29 dBm) are not detected and regenerated.
- 30 4. Uses the 40-bit DSP math library.

31

9 CODEBOOK MEMORIES AND CONSTANTS

Table 9-1 LSP Quantization Table, Rate 1, Codebook 1

<i>j</i>	$q_{rate}(1, 1, j)$	$q_{rate}(1, 2, j)$	<i>j</i>	$q_{rate}(1, 1, j)$	$q_{rate}(1, 2, j)$	<i>j</i>	$q_{rate}(1, 1, j)$	$q_{rate}(1, 2, j)$
1	1.420163E-2	1.938816E-2	23	3.891726E-2	5.657889E-2	45	3.185912E-2	4.621231E-2
2	2.916675E-2	6.517492E-2	24	6.048006E-2	1.045370E-1	46	6.189098E-2	7.332318E-2
3	2.066932E-2	4.975649E-2	25	2.691566E-2	3.571689E-2	47	4.417184E-2	5.792409E-2
4	3.947198E-2	9.558509E-2	26	4.111172E-2	7.333230E-2	48	7.935962E-2	1.411774E-1
5	2.270125E-2	3.966258E-2	27	4.126607E-2	4.851652E-2	49	2.474123E-2	3.236294E-2
6	5.387895E-2	6.283478E-2	28	7.180496E-2	1.062024E-1	50	3.365639E-2	8.046506E-2
7	2.905255E-2	5.734358E-2	29	3.380379E-2	4.243004E-2	51	3.379437E-2	5.449772E-2
8	4.482806E-2	1.153646E-1	30	5.918182E-2	7.974680E-2	52	6.536490E-2	9.527759E-2
9	1.941107E-2	3.468897E-2	31	4.701079E-2	6.285638E-2	53	2.933642E-2	4.284110E-2
10	4.375030E-2	6.752285E-2	32	9.420119E-2	1.300532E-1	54	5.278705E-2	8.161594E-2
11	3.554973E-2	4.940868E-2	33	1.942443E-2	2.727323E-2	55	4.007249E-2	6.181447E-2
12	6.992199E-2	8.672798E-2	34	3.708317E-2	6.648982E-2	56	6.758486E-2	1.171961E-1
13	2.778802E-2	4.657485E-2	35	2.801364E-2	5.159849E-2	57	3.030650E-2	3.869141E-2
14	5.791110E-2	6.745425E-2	36	5.344610E-2	9.259042E-2	58	4.831063E-2	7.423830E-2
15	4.746644E-2	5.502715E-2	37	2.549592E-2	4.328448E-2	59	4.375483E-2	5.228423E-2
16	7.888989E-2	1.224430E-1	38	5.518607E-2	7.361823E-2	60	8.323100E-2	1.098820E-1
17	2.217159E-2	3.026288E-2	39	3.398511E-2	6.053291E-2	61	3.756006E-2	4.532172E-2
18	3.391345E-2	7.177040E-2	40	6.181821E-2	1.345813E-1	62	6.601132E-2	7.975802E-2
19	3.179891E-2	4.989961E-2	41	2.356692E-2	3.552420E-2	63	5.032251E-2	5.901763E-2
20	6.115560E-2	8.733612E-2	42	5.108042E-2	6.795625E-2	64	8.771333E-2	1.631874E-1
21	2.675065E-2	3.967359E-2	43	3.834650E-2	5.234694E-2			
22	4.441010E-2	8.267313E-2	44	7.442758E-2	9.661083E-2			

Table 9-2 LSP Quantization Table, Rate 1, Codebook 2

<i>j</i>	$q_{rate}(2, 1, j)$	$q_{rate}(2, 2, j)$	<i>j</i>	$q_{rate}(2, 1, j)$	$q_{rate}(2, 2, j)$	<i>j</i>	$q_{rate}(2, 1, j)$	$q_{rate}(2, 2, j)$
1	5.219596E-2	8.384457E-2	23	9.266608E-2	1.467255E-1	45	7.772978E-2	1.202872E-1
2	1.058741E-1	1.286942E-1	24	1.792855E-1	2.197060E-1	46	1.306480E-1	1.843318E-1
3	5.483239E-2	1.338429E-1	25	7.064585E-2	9.999245E-2	47	6.919396E-2	1.842180E-1
4	1.177685E-1	1.940373E-1	26	1.065005E-1	1.794434E-1	48	2.039041E-1	2.497152E-1
5	5.360865E-2	1.113987E-1	27	8.792497E-2	1.252877E-1	49	7.076717E-2	9.031861E-2
6	1.199897E-1	1.474747E-1	28	1.536402E-1	1.978527E-1	50	1.084716E-1	1.619665E-1
7	8.003736E-2	1.429997E-1	29	8.884301E-2	1.124657E-1	51	7.168864E-2	1.510932E-1
8	1.640866E-1	2.098218E-1	30	1.482867E-1	1.675170E-1	52	1.387795E-1	2.188018E-1
9	5.210592E-2	9.952294E-2	31	8.165681E-2	1.692740E-1	53	6.759071E-2	1.267403E-1
10	8.675680E-2	1.859665E-1	32	2.078105E-1	2.310336E-1	54	1.334124E-1	1.688389E-1
11	7.773411E-2	1.315069E-1	33	6.149280E-2	8.362632E-2	55	9.618226E-2	1.587287E-1
12	1.605455E-1	1.819303E-1	34	1.144733E-1	1.367800E-1	56	1.864856E-1	2.365609E-1
13	7.422437E-2	1.104371E-1	35	6.871299E-2	1.380991E-1	57	8.234471E-2	1.021260E-1
14	1.186351E-1	1.753068E-1	36	1.105114E-1	2.153529E-1	58	1.003366E-1	1.949185E-1
15	6.615578E-2	1.644419E-1	37	5.556523E-2	1.222428E-1	59	9.959820E-2	1.364251E-1
16	1.968109E-1	2.166820E-1	38	1.205576E-1	1.610725E-1	60	1.824485E-1	2.036552E-1

17	6.053178E-2	9.454086E-2	39	8.322497E-2	1.554755E-1	61	9.788907E-2	1.211455E-1
18	1.062714E-1	1.480139E-1	40	1.616385E-1	2.282689E-1	62	1.454531E-1	1.836045E-1
19	5.874866E-2	1.477246E-1	41	6.291523E-2	1.062296E-1	63	9.583955E-2	1.721949E-1
20	1.348165E-1	2.015180E-1	42	8.291869E-2	2.067745E-1	64	2.232959E-1	2.464186E-1
21	6.596983E-2	1.164474E-1	43	8.847569E-2	1.358000E-1			
22	1.322972E-1	1.532673E-1	44	1.697722E-1	1.937739E-1			

1  
2

**Table 9-3 LSP Quantization Table, Rate 1, Codebook 3**

<i>j</i>	$q_{rate}(3, 1, j)$	$q_{rate}(3, 2, j)$	$q_{rate}(3, 3, j)$	<i>j</i>	$q_{rate}(3, 1, j)$	$q_{rate}(3, 2, j)$	$q_{rate}(3, 3, j)$
1	1.364258E-1	1.686519E-1	2.046882E-1	257	1.476240E-1	1.812728E-1	2.047079E-1
2	1.857176E-1	2.287562E-1	2.519580E-1	258	1.937514E-1	2.209740E-1	2.617752E-1
3	1.227602E-1	1.859507E-1	2.794467E-1	259	1.320898E-1	1.948516E-1	2.835476E-1
4	1.964685E-1	2.644844E-1	2.893189E-1	260	2.077394E-1	2.705968E-1	2.922648E-1
5	1.256537E-1	1.505293E-1	2.761443E-1	261	1.277334E-1	1.668960E-1	2.838914E-1
6	1.963016E-1	2.417000E-1	2.882307E-1	262	2.053094E-1	2.478075E-1	2.836328E-1
7	1.400994E-1	2.223656E-1	2.746666E-1	263	1.542119E-1	2.250141E-1	2.700820E-1
8	2.599523E-1	2.753950E-1	3.109759E-1	264	2.675741E-1	2.844269E-1	3.093348E-1
9	1.584522E-1	1.885910E-1	2.073392E-1	265	1.688469E-1	1.870045E-1	2.024332E-1
10	1.956162E-1	2.213795E-1	2.870229E-1	266	2.024411E-1	2.167331E-1	2.930792E-1
11	1.694246E-1	2.016147E-1	2.756692E-1	267	1.636213E-1	2.156165E-1	2.827929E-1
12	2.123938E-1	2.642507E-1	3.179675E-1	268	2.255093E-1	2.662830E-1	3.178866E-1
13	1.829651E-1	1.995476E-1	2.295388E-1	269	1.891103E-1	2.056094E-1	2.221136E-1
14	2.152007E-1	2.624094E-1	2.824327E-1	270	2.212402E-1	2.602889E-1	2.925411E-1
15	1.464046E-1	2.369667E-1	2.900671E-1	271	1.555634E-1	2.468508E-1	2.896488E-1
16	2.453386E-1	3.033581E-1	3.422602E-1	272	2.484062E-1	3.052919E-1	3.553167E-1
17	1.374790E-1	1.582766E-1	2.392172E-1	273	1.271222E-1	1.580537E-1	2.541644E-1
18	2.019990E-1	2.201026E-1	2.695469E-1	274	2.049988E-1	2.194769E-1	2.783420E-1
19	1.183500E-1	2.302064E-1	2.835548E-1	275	1.333023E-1	2.296140E-1	2.869472E-1
20	2.255193E-1	2.722721E-1	3.060730E-1	276	2.367771E-1	2.679182E-1	3.082309E-1
21	1.356614E-1	1.916340E-1	2.659120E-1	277	1.408536E-1	2.034147E-1	2.732571E-1
22	1.957331E-1	2.319262E-1	3.143761E-1	278	2.076843E-1	2.345200E-1	3.245833E-1
23	1.679990E-1	2.277063E-1	2.769478E-1	279	1.771817E-1	2.295954E-1	2.835392E-1
24	2.501706E-1	3.016271E-1	3.210842E-1	280	2.613784E-1	3.011602E-1	3.217071E-1
25	1.334923E-1	2.012231E-1	2.338940E-1	281	1.485957E-1	2.077720E-1	2.469461E-1
26	2.064421E-1	2.387042E-1	2.775601E-1	282	2.143348E-1	2.480613E-1	2.722592E-1
27	1.790488E-1	1.957766E-1	2.806566E-1	283	1.763803E-1	1.968979E-1	2.922869E-1
28	2.061936E-1	2.640554E-1	3.330984E-1	284	1.981935E-1	2.754833E-1	3.490376E-1
29	1.751853E-1	1.911663E-1	2.575403E-1	285	1.761532E-1	1.932490E-1	2.695485E-1
30	2.283986E-1	2.452967E-1	3.089808E-1	286	2.369686E-1	2.500658E-1	3.068208E-1
31	1.808598E-1	2.435791E-1	2.966311E-1	287	1.760607E-1	2.540376E-1	3.035668E-1
32	2.761530E-1	3.082561E-1	3.468226E-1	288	2.829529E-1	3.017651E-1	3.539563E-1
33	1.371157E-1	1.800578E-1	2.209535E-1	289	1.453537E-1	1.836788E-1	2.347501E-1
34	1.813701E-1	2.267701E-1	2.703927E-1	290	1.938426E-1	2.306356E-1	2.678178E-1
35	1.252465E-1	1.796069E-1	3.103764E-1	291	1.389590E-1	1.867608E-1	3.131132E-1
36	1.907084E-1	2.877342E-1	3.134762E-1	292	1.999445E-1	2.776248E-1	3.250463E-1
37	1.304861E-1	1.604353E-1	3.002437E-1	293	1.429661E-1	1.713108E-1	3.030134E-1
38	1.973186E-1	2.563785E-1	2.784743E-1	294	2.077417E-1	2.586918E-1	2.887670E-1

39	1.585971E-1	2.373814E-1	2.629103E-1	295	1.717769E-1	2.402461E-1	2.732845E-1
40	2.618259E-1	2.777172E-1	3.313822E-1	296	2.710466E-1	2.851709E-1	3.274011E-1
41	1.641607E-1	1.858415E-1	2.356159E-1	297	1.698546E-1	1.875458E-1	2.244847E-1
42	2.094861E-1	2.214528E-1	2.921539E-1	298	2.152220E-1	2.273397E-1	2.950088E-1
43	1.668079E-1	2.136418E-1	2.706759E-1	299	1.755966E-1	2.179366E-1	2.748796E-1
44	2.298343E-1	2.883746E-1	3.062383E-1	300	2.346654E-1	2.895309E-1	3.164944E-1
45	1.821543E-1	2.008225E-1	2.401694E-1	301	1.899470E-1	2.049538E-1	2.469552E-1
46	2.249447E-1	2.698139E-1	2.914012E-1	302	2.372978E-1	2.683167E-1	2.906843E-1
47	1.639406E-1	2.503412E-1	2.783078E-1	303	1.699632E-1	2.533675E-1	2.925330E-1
48	2.567280E-1	2.951038E-1	3.532971E-1	304	2.706599E-1	2.971461E-1	3.561840E-1
49	1.402188E-1	1.766877E-1	2.467733E-1	305	1.525397E-1	1.701390E-1	2.527039E-1
50	2.152913E-1	2.292160E-1	2.642836E-1	306	2.191192E-1	2.359007E-1	2.697391E-1
51	1.210027E-1	2.183338E-1	3.223413E-1	307	1.422457E-1	2.181846E-1	3.282181E-1
52	2.542432E-1	2.739862E-1	2.962625E-1	308	2.614728E-1	2.780257E-1	3.023759E-1
53	1.603854E-1	1.837629E-1	2.815987E-1	309	1.535260E-1	1.907277E-1	2.928208E-1
54	1.878322E-1	2.374204E-1	3.297775E-1	310	2.092410E-1	2.498087E-1	3.247091E-1
55	1.777884E-1	2.267035E-1	3.023225E-1	311	1.751764E-1	2.386468E-1	3.063927E-1
56	2.751082E-1	2.937306E-1	3.123738E-1	312	2.732189E-1	3.039550E-1	3.205139E-1
57	1.701164E-1	1.852321E-1	2.461250E-1	313	1.639116E-1	1.896116E-1	2.562725E-1
58	2.217548E-1	2.399122E-1	2.868919E-1	314	2.269538E-1	2.401202E-1	2.927285E-1
59	1.950837E-1	2.083379E-1	2.883497E-1	315	1.955657E-1	2.119562E-1	2.973747E-1
60	2.375365E-1	2.750045E-1	3.397860E-1	316	2.410456E-1	2.884970E-1	3.363523E-1
61	1.883693E-1	2.043718E-1	2.573750E-1	317	1.949483E-1	2.094753E-1	2.563097E-1
62	2.472502E-1	2.605518E-1	3.021375E-1	318	2.478846E-1	2.633564E-1	3.112709E-1
63	1.669442E-1	2.469124E-1	3.188944E-1	319	1.691897E-1	2.358646E-1	3.362494E-1
64	2.781186E-1	3.130111E-1	3.653293E-1	320	2.860016E-1	3.254238E-1	3.596074E-1
65	1.452135E-1	1.630515E-1	2.249126E-1	321	1.562586E-1	1.767049E-1	2.143934E-1
66	2.056925E-1	2.208315E-1	2.528178E-1	322	2.089969E-1	2.239687E-1	2.608868E-1
67	1.211257E-1	1.963741E-1	3.001227E-1	323	1.357654E-1	2.035801E-1	3.055032E-1
68	2.155668E-1	2.656573E-1	2.992029E-1	324	2.189614E-1	2.794635E-1	2.994508E-1
69	1.091342E-1	1.784721E-1	2.883232E-1	325	1.340648E-1	1.783321E-1	2.901696E-1
70	2.035085E-1	2.403479E-1	2.963097E-1	326	2.132984E-1	2.400315E-1	3.003459E-1
71	1.531018E-1	2.254153E-1	2.848437E-1	327	1.643734E-1	2.264387E-1	2.871712E-1
72	2.502334E-1	2.777369E-1	3.248407E-1	328	2.507396E-1	2.808125E-1	3.353494E-1
73	1.663089E-1	1.941734E-1	2.116354E-1	329	1.636495E-1	1.971080E-1	2.211652E-1
74	2.012895E-1	2.260622E-1	2.932465E-1	330	2.081396E-1	2.308698E-1	2.961371E-1
75	1.495188E-1	2.142017E-1	2.838948E-1	331	1.591131E-1	2.181892E-1	2.955320E-1
76	2.218361E-1	2.852315E-1	3.200826E-1	332	2.398835E-1	2.818312E-1	3.260456E-1
77	1.895732E-1	2.065776E-1	2.303323E-1	333	1.893947E-1	2.081271E-1	2.384464E-1
78	2.312477E-1	2.468643E-1	2.898466E-1	334	2.329957E-1	2.596035E-1	2.934280E-1
79	1.391169E-1	2.591899E-1	2.980196E-1	335	1.605588E-1	2.551648E-1	3.028729E-1
80	2.445126E-1	2.826714E-1	3.612583E-1	336	2.535093E-1	2.960285E-1	3.677216E-1
81	1.225310E-1	1.685148E-1	2.708793E-1	337	1.301244E-1	1.748390E-1	2.604860E-1
82	2.043728E-1	2.303984E-1	2.717929E-1	338	2.102040E-1	2.335708E-1	2.830619E-1
83	1.426439E-1	2.224056E-1	2.920572E-1	339	1.523655E-1	2.253388E-1	3.037210E-1
84	2.426437E-1	2.774294E-1	2.971355E-1	340	2.405586E-1	2.771922E-1	3.058919E-1
85	1.520486E-1	1.969211E-1	2.610132E-1	341	1.637288E-1	1.947794E-1	2.692536E-1
86	2.178750E-1	2.458404E-1	3.081386E-1	342	2.257094E-1	2.409027E-1	3.180606E-1

3GPP2 C.S0014-C ver 1.0

87	1.901093E-1	2.310991E-1	2.801782E-1	343	1.920551E-1	2.298578E-1	2.898267E-1
88	2.543142E-1	2.940798E-1	3.396492E-1	344	2.627597E-1	3.042922E-1	3.356806E-1
89	1.566986E-1	2.085975E-1	2.280108E-1	345	1.660712E-1	2.068192E-1	2.397125E-1
90	2.250887E-1	2.500145E-1	2.762502E-1	346	2.239156E-1	2.501069E-1	2.852962E-1
91	1.782190E-1	1.982282E-1	3.041989E-1	347	1.884023E-1	2.037937E-1	3.030411E-1
92	2.085672E-1	2.923954E-1	3.467869E-1	348	2.306990E-1	2.870441E-1	3.498028E-1
93	1.710521E-1	2.034388E-1	2.626443E-1	349	1.820254E-1	2.140735E-1	2.634700E-1
94	2.302755E-1	2.588175E-1	3.119865E-1	350	2.372978E-1	2.650254E-1	3.178155E-1
95	1.853336E-1	2.457602E-1	3.105540E-1	351	1.892787E-1	2.588022E-1	3.048662E-1
96	2.894139E-1	3.110956E-1	3.464762E-1	352	2.972431E-1	3.171531E-1	3.565839E-1
97	1.503324E-1	1.675382E-1	2.401829E-1	353	1.586075E-1	1.786598E-1	2.419194E-1
98	1.799717E-1	2.371686E-1	2.608997E-1	354	1.948874E-1	2.416959E-1	2.621767E-1
99	1.498662E-1	1.978901E-1	3.079166E-1	355	1.581244E-1	2.117531E-1	3.113522E-1
100	2.107997E-1	2.881801E-1	3.297472E-1	356	2.169027E-1	2.987968E-1	3.209941E-1
101	1.317111E-1	1.659065E-1	3.228980E-1	357	1.492728E-1	1.749641E-1	3.153344E-1
102	2.148320E-1	2.528221E-1	2.975471E-1	358	2.216223E-1	2.561791E-1	3.039030E-1
103	1.837604E-1	2.375236E-1	2.746100E-1	359	1.759796E-1	2.435055E-1	2.858017E-1
104	2.555752E-1	2.754392E-1	3.460219E-1	360	2.645904E-1	2.855416E-1	3.451078E-1
105	1.826622E-1	1.994709E-1	2.160517E-1	361	1.801371E-1	2.052794E-1	2.222560E-1
106	2.092403E-1	2.224067E-1	3.023829E-1	362	2.107962E-1	2.263154E-1	3.144269E-1
107	1.840883E-1	2.113278E-1	2.825381E-1	363	1.791512E-1	2.094397E-1	2.932809E-1
108	2.411711E-1	2.970360E-1	3.159793E-1	364	2.497190E-1	2.912577E-1	3.271623E-1
109	1.968047E-1	2.118159E-1	2.416477E-1	365	1.987002E-1	2.158968E-1	2.499602E-1
110	2.427620E-1	2.585866E-1	2.932044E-1	366	2.407264E-1	2.648577E-1	2.996396E-1
111	1.589055E-1	2.650770E-1	2.898813E-1	367	1.712497E-1	2.681662E-1	3.035727E-1
112	2.580606E-1	3.189032E-1	3.478468E-1	368	2.695556E-1	3.161006E-1	3.565707E-1
113	1.487664E-1	1.668539E-1	2.668274E-1	369	1.505648E-1	1.841909E-1	2.686748E-1
114	2.159423E-1	2.299383E-1	2.760416E-1	370	2.169412E-1	2.408140E-1	2.789422E-1
115	1.384105E-1	2.392834E-1	3.279724E-1	371	1.353995E-1	2.605865E-1	3.326049E-1
116	2.437653E-1	2.884085E-1	3.060487E-1	372	2.561510E-1	2.878229E-1	3.061564E-1
117	1.701571E-1	1.899863E-1	2.812192E-1	373	1.663988E-1	1.887218E-1	2.930237E-1
118	2.191170E-1	2.580053E-1	3.265720E-1	374	2.292141E-1	2.615654E-1	3.274941E-1
119	1.921636E-1	2.236142E-1	2.986831E-1	375	1.982666E-1	2.329705E-1	2.991343E-1
120	2.735454E-1	3.120781E-1	3.307666E-1	376	2.870463E-1	3.071038E-1	3.272981E-1
121	1.624521E-1	2.049309E-1	2.533377E-1	377	1.758987E-1	2.118986E-1	2.513329E-1
122	2.238553E-1	2.376711E-1	3.032020E-1	378	2.320674E-1	2.446222E-1	2.994437E-1
123	1.939553E-1	2.123356E-1	3.075669E-1	379	1.907801E-1	2.120900E-1	3.250593E-1
124	2.299127E-1	2.975811E-1	3.374992E-1	380	2.315312E-1	3.141661E-1	3.427359E-1
125	1.893354E-1	2.041481E-1	2.786098E-1	381	1.950999E-1	2.095543E-1	2.794835E-1
126	2.423036E-1	2.731631E-1	3.153617E-1	382	2.404161E-1	2.696048E-1	3.280155E-1
127	1.550097E-1	2.880952E-1	3.359964E-1	383	1.718009E-1	2.822331E-1	3.147493E-1
128	2.737162E-1	3.312155E-1	3.625391E-1	384	2.692438E-1	3.384625E-1	3.799357E-1
129	1.523894E-1	1.726191E-1	1.905857E-1	385	1.599346E-1	1.779668E-1	2.008186E-1
130	1.969883E-1	2.263098E-1	2.461975E-1	386	2.019797E-1	2.306685E-1	2.567733E-1
131	1.205552E-1	2.063698E-1	2.811998E-1	387	1.340243E-1	2.109616E-1	2.846877E-1
132	1.937094E-1	2.719005E-1	3.013329E-1	388	2.037129E-1	2.830531E-1	3.033094E-1
133	1.367012E-1	1.540932E-1	2.822584E-1	389	1.445289E-1	1.647281E-1	2.850794E-1
134	1.972992E-1	2.536563E-1	2.903151E-1	390	2.062856E-1	2.486490E-1	2.963831E-1

135	1.434638E-1	2.438729E-1	2.755337E-1	391	1.581382E-1	2.343177E-1	2.796500E-1
136	2.584773E-1	2.732799E-1	3.211191E-1	392	2.649956E-1	2.799007E-1	3.186194E-1
137	1.544062E-1	1.937935E-1	2.158842E-1	393	1.665375E-1	1.842794E-1	2.145475E-1
138	2.059795E-1	2.242770E-1	2.857324E-1	394	2.030519E-1	2.351105E-1	2.887560E-1
139	1.745353E-1	2.084824E-1	2.796685E-1	395	1.684227E-1	2.039462E-1	2.874789E-1
140	2.188446E-1	2.724863E-1	3.270956E-1	396	2.317270E-1	2.740864E-1	3.247552E-1
141	1.776097E-1	2.129902E-1	2.391197E-1	397	1.853562E-1	2.141131E-1	2.290304E-1
142	2.291638E-1	2.591659E-1	2.835147E-1	398	2.424826E-1	2.606555E-1	2.830303E-1
143	1.573532E-1	2.399613E-1	3.042631E-1	399	1.675623E-1	2.420275E-1	2.994620E-1
144	2.456138E-1	3.168245E-1	3.429094E-1	400	2.388099E-1	3.190039E-1	3.584159E-1
145	1.429532E-1	1.619054E-1	2.537102E-1	401	1.379083E-1	1.547878E-1	2.656112E-1
146	2.101928E-1	2.228477E-1	2.711038E-1	402	2.110193E-1	2.246073E-1	2.799547E-1
147	1.268439E-1	2.167091E-1	2.977347E-1	403	1.375699E-1	2.251285E-1	3.093129E-1
148	2.310001E-1	2.801091E-1	2.997074E-1	404	2.292399E-1	2.761510E-1	3.152418E-1
149	1.529805E-1	1.939969E-1	2.728957E-1	405	1.604875E-1	1.954612E-1	2.831695E-1
150	2.128607E-1	2.415454E-1	3.165188E-1	406	2.185057E-1	2.381972E-1	3.303401E-1
151	1.711547E-1	2.224697E-1	2.937865E-1	407	1.819913E-1	2.330270E-1	2.932760E-1
152	2.519882E-1	3.042550E-1	3.312700E-1	408	2.545523E-1	3.143942E-1	3.363923E-1
153	1.331889E-1	2.079250E-1	2.553621E-1	409	1.440958E-1	2.266402E-1	2.505951E-1
154	2.120449E-1	2.421897E-1	2.889037E-1	410	2.151880E-1	2.514173E-1	2.850440E-1
155	1.846125E-1	2.011436E-1	2.863608E-1	411	1.876744E-1	2.044589E-1	2.941690E-1
156	2.182867E-1	2.767524E-1	3.445815E-1	412	2.304948E-1	2.684524E-1	3.523701E-1
157	1.835622E-1	1.994785E-1	2.621566E-1	413	1.850221E-1	1.990753E-1	2.719306E-1
158	2.331305E-1	2.495969E-1	3.158428E-1	414	2.425694E-1	2.553892E-1	3.113993E-1
159	1.898990E-1	2.468749E-1	2.971325E-1	415	1.951661E-1	2.491021E-1	2.989985E-1
160	2.750225E-1	3.224903E-1	3.469777E-1	416	2.836542E-1	3.146003E-1	3.556194E-1
161	1.423053E-1	1.926892E-1	2.161559E-1	417	1.514900E-1	1.977298E-1	2.324675E-1
162	1.956762E-1	2.222686E-1	2.765874E-1	418	2.000299E-1	2.301013E-1	2.819339E-1
163	1.332415E-1	1.977918E-1	3.228979E-1	419	1.387113E-1	1.918166E-1	3.457804E-1
164	1.848651E-1	2.971062E-1	3.261052E-1	420	1.965804E-1	3.047148E-1	3.405534E-1
165	1.502037E-1	1.767813E-1	2.915362E-1	421	1.381543E-1	1.885431E-1	2.994612E-1
166	2.031445E-1	2.596162E-1	2.991560E-1	422	2.056665E-1	2.689049E-1	3.055372E-1
167	1.654890E-1	2.383421E-1	2.874939E-1	423	1.724479E-1	2.335584E-1	2.936252E-1
168	2.710713E-1	2.895445E-1	3.195210E-1	424	2.701454E-1	2.986548E-1	3.285564E-1
169	1.685984E-1	1.988256E-1	2.303476E-1	425	1.754894E-1	1.913616E-1	2.355853E-1
170	2.138117E-1	2.344718E-1	2.909596E-1	426	2.205488E-1	2.347740E-1	2.953977E-1
171	1.746054E-1	2.172560E-1	2.856881E-1	427	1.856524E-1	2.223491E-1	2.798839E-1
172	2.285035E-1	2.961903E-1	3.165347E-1	428	2.294570E-1	3.045463E-1	3.246843E-1
173	1.871726E-1	2.205474E-1	2.396887E-1	429	1.869008E-1	2.154694E-1	2.518568E-1
174	2.288848E-1	2.635832E-1	3.013295E-1	430	2.349105E-1	2.712174E-1	2.998947E-1
175	1.778971E-1	2.581315E-1	2.814877E-1	431	1.851424E-1	2.560710E-1	2.932913E-1
176	2.595136E-1	3.072044E-1	3.487936E-1	432	2.638837E-1	3.071275E-1	3.625467E-1
177	1.452244E-1	1.787160E-1	2.591870E-1	433	1.609976E-1	1.789379E-1	2.558083E-1
178	2.190623E-1	2.382235E-1	2.604615E-1	434	2.256711E-1	2.437351E-1	2.686250E-1
179	1.436509E-1	2.097608E-1	3.158302E-1	435	1.550762E-1	2.303962E-1	3.210056E-1
180	2.501275E-1	2.791823E-1	3.051536E-1	436	2.517605E-1	2.796534E-1	3.142022E-1
181	1.489864E-1	2.012268E-1	2.825437E-1	437	1.569888E-1	2.074669E-1	2.899340E-1
182	2.083878E-1	2.356039E-1	3.453639E-1	438	2.174795E-1	2.596264E-1	3.406591E-1

3GPP2 C.S0014-C ver 1.0

183	1.858303E-1	2.216073E-1	3.107736E-1	439	1.768115E-1	2.310871E-1	3.175625E-1
184	2.809047E-1	2.954698E-1	3.254995E-1	440	2.829526E-1	2.998444E-1	3.368229E-1
185	1.729673E-1	1.970781E-1	2.458011E-1	441	1.820603E-1	1.987347E-1	2.519803E-1
186	2.194957E-1	2.447671E-1	2.935878E-1	442	2.258742E-1	2.524692E-1	2.933564E-1
187	1.839096E-1	2.150043E-1	3.003345E-1	443	2.008000E-1	2.177869E-1	3.022101E-1
188	2.453386E-1	2.685953E-1	3.483304E-1	444	2.474238E-1	2.868829E-1	3.478206E-1
189	1.929574E-1	2.066251E-1	2.673364E-1	445	2.011281E-1	2.147469E-1	2.622697E-1
190	2.548456E-1	2.686423E-1	3.035479E-1	446	2.539634E-1	2.694780E-1	3.121338E-1
191	1.768531E-1	2.593310E-1	3.162008E-1	447	1.910349E-1	2.557382E-1	3.325596E-1
192	2.909291E-1	3.156348E-1	3.687235E-1	448	2.910537E-1	3.314584E-1	3.685885E-1
193	1.571170E-1	1.735529E-1	2.287365E-1	449	1.572299E-1	1.853741E-1	2.253613E-1
194	2.125093E-1	2.305012E-1	2.522180E-1	450	2.080513E-1	2.383509E-1	2.642129E-1
195	1.425218E-1	2.019799E-1	2.930122E-1	451	1.468483E-1	2.130001E-1	3.001926E-1
196	2.149197E-1	2.780651E-1	3.141761E-1	452	2.186306E-1	2.902638E-1	3.090458E-1
197	1.359473E-1	1.810559E-1	2.754754E-1	453	1.436992E-1	1.878152E-1	2.837699E-1
198	1.984167E-1	2.416738E-1	3.051734E-1	454	2.073280E-1	2.450887E-1	3.089564E-1
199	1.595173E-1	2.315801E-1	2.954125E-1	455	1.642281E-1	2.278267E-1	3.089079E-1
200	2.582036E-1	2.873481E-1	3.203520E-1	456	2.619197E-1	2.913337E-1	3.315280E-1
201	1.748407E-1	1.928833E-1	2.112500E-1	457	1.706489E-1	2.021575E-1	2.178278E-1
202	2.021685E-1	2.270257E-1	3.048841E-1	458	2.077961E-1	2.347048E-1	3.067838E-1
203	1.695321E-1	2.118262E-1	2.973554E-1	459	1.721188E-1	2.140574E-1	3.101518E-1
204	2.300337E-1	2.915044E-1	3.265894E-1	460	2.291162E-1	2.809499E-1	3.337743E-1
205	1.950461E-1	2.117092E-1	2.277058E-1	461	1.966222E-1	2.166531E-1	2.332797E-1
206	2.379269E-1	2.524116E-1	2.977522E-1	462	2.377892E-1	2.589713E-1	3.046092E-1
207	1.537629E-1	2.465416E-1	3.147689E-1	463	1.551820E-1	2.630326E-1	3.189431E-1
208	2.360757E-1	3.035689E-1	3.706245E-1	464	2.493888E-1	3.169709E-1	3.777625E-1
209	1.386603E-1	1.679500E-1	2.735153E-1	465	1.513636E-1	1.750107E-1	2.782458E-1
210	2.138062E-1	2.272672E-1	2.862763E-1	466	2.198102E-1	2.323602E-1	2.850349E-1
211	1.250806E-1	2.440984E-1	3.025488E-1	467	1.426306E-1	2.406029E-1	3.041251E-1
212	2.357149E-1	2.812088E-1	3.089037E-1	468	2.427649E-1	2.837621E-1	3.154812E-1
213	1.516914E-1	2.108778E-1	2.638130E-1	469	1.574675E-1	2.075241E-1	2.756749E-1
214	2.207304E-1	2.527779E-1	3.164137E-1	470	2.287586E-1	2.490922E-1	3.281394E-1
215	1.849247E-1	2.394248E-1	2.851208E-1	471	1.908727E-1	2.381252E-1	2.948946E-1
216	2.595485E-1	3.098099E-1	3.264237E-1	472	2.663893E-1	3.143214E-1	3.386695E-1
217	1.629307E-1	2.199009E-1	2.361486E-1	473	1.706442E-1	2.259800E-1	2.473724E-1
218	2.341942E-1	2.499443E-1	2.775491E-1	474	2.364428E-1	2.530035E-1	2.882204E-1
219	1.708702E-1	1.982916E-1	3.214126E-1	475	1.854238E-1	2.048889E-1	3.146088E-1
220	2.315669E-1	2.750151E-1	3.697104E-1	476	2.173790E-1	2.945536E-1	3.678310E-1
221	1.800024E-1	2.067010E-1	2.712049E-1	477	1.885640E-1	2.151743E-1	2.729997E-1
222	2.380753E-1	2.540062E-1	3.238276E-1	478	2.451021E-1	2.597704E-1	3.218856E-1
223	1.991483E-1	2.542739E-1	3.074797E-1	479	1.984442E-1	2.611607E-1	3.170979E-1
224	2.874286E-1	3.250451E-1	3.486346E-1	480	2.990139E-1	3.289653E-1	3.566812E-1
225	1.452850E-1	1.913592E-1	2.496914E-1	481	1.582488E-1	1.922057E-1	2.460591E-1
226	1.946593E-1	2.408212E-1	2.773027E-1	482	2.023854E-1	2.479658E-1	2.717497E-1
227	1.531510E-1	1.943757E-1	3.275504E-1	483	1.617108E-1	2.137081E-1	3.273847E-1
228	2.040858E-1	2.985957E-1	3.214801E-1	484	2.144197E-1	3.055525E-1	3.337216E-1
229	1.560097E-1	1.810127E-1	3.009317E-1	485	1.618200E-1	1.898973E-1	3.105016E-1
230	2.109624E-1	2.557703E-1	3.080861E-1	486	2.194363E-1	2.650296E-1	3.092888E-1

231	1.854441E-1	2.490213E-1	2.740298E-1	487	1.883039E-1	2.496332E-1	2.854995E-1
232	2.744935E-1	2.894420E-1	3.387949E-1	488	2.693254E-1	2.998070E-1	3.417225E-1
233	1.769419E-1	1.944769E-1	2.220773E-1	489	1.724060E-1	2.109773E-1	2.277732E-1
234	2.163775E-1	2.307358E-1	3.036893E-1	490	2.202815E-1	2.340158E-1	3.128461E-1
235	1.896835E-1	2.146608E-1	2.884454E-1	491	1.832573E-1	2.220620E-1	2.910524E-1
236	2.408273E-1	2.981418E-1	3.273784E-1	492	2.425312E-1	3.095276E-1	3.303897E-1
237	2.017878E-1	2.194418E-1	2.393275E-1	493	2.075467E-1	2.246626E-1	2.444201E-1
238	2.488125E-1	2.658659E-1	2.933824E-1	494	2.458582E-1	2.702860E-1	3.051321E-1
239	1.820278E-1	2.682791E-1	2.939914E-1	495	1.848406E-1	2.720968E-1	3.125311E-1
240	2.564986E-1	3.199845E-1	3.626632E-1	496	2.742526E-1	3.212524E-1	3.746582E-1
241	1.587993E-1	1.754337E-1	2.673899E-1	497	1.664258E-1	1.844916E-1	2.682781E-1
242	2.242593E-1	2.366683E-1	2.776391E-1	498	2.284237E-1	2.430254E-1	2.811849E-1
243	1.492034E-1	2.265853E-1	3.452556E-1	499	1.600913E-1	2.529533E-1	3.358223E-1
244	2.506558E-1	2.922649E-1	3.135743E-1	500	2.621100E-1	2.955819E-1	3.133541E-1
245	1.580963E-1	2.021932E-1	2.987117E-1	501	1.677028E-1	2.015369E-1	3.018016E-1
246	2.288209E-1	2.485573E-1	3.447265E-1	502	2.378230E-1	2.598948E-1	3.382311E-1
247	1.879721E-1	2.341094E-1	3.042356E-1	503	1.972062E-1	2.454909E-1	3.178954E-1
248	2.856571E-1	3.148781E-1	3.369315E-1	504	2.984553E-1	3.192098E-1	3.409717E-1
249	1.626800E-1	2.178201E-1	2.574368E-1	505	1.711953E-1	2.243278E-1	2.627361E-1
250	2.240498E-1	2.467398E-1	3.007959E-1	506	2.306269E-1	2.533102E-1	3.012068E-1
251	2.013546E-1	2.182867E-1	3.130363E-1	507	2.048142E-1	2.218816E-1	3.259666E-1
252	2.380285E-1	2.981035E-1	3.535038E-1	508	2.229875E-1	3.063391E-1	3.507172E-1
253	1.988300E-1	2.128771E-1	2.729808E-1	509	2.008554E-1	2.153599E-1	2.841435E-1
254	2.506165E-1	2.676600E-1	3.206119E-1	510	2.509517E-1	2.661893E-1	3.333606E-1
255	1.709018E-1	2.693304E-1	3.344282E-1	511	1.756103E-1	2.937913E-1	3.403269E-1
256	3.049889E-1	3.361967E-1	3.652354E-1	512	2.917451E-1	3.406025E-1	3.813972E-1

1

2

**Table 9-4 LSP Quantization Table, Rate 1, Codebook 4**

$j$	$q_{rate}(4, 1, j)$	$q_{rate}(4, 2, j)$	$q_{rate}(4, 3, j)$	$j$	$q_{rate}(4, 1, j)$	$q_{rate}(4, 2, j)$	$q_{rate}(4, 3, j)$
1	2.774615E-1	3.169721E-1	3.954983E-1	65	2.491101E-1	3.256969E-1	4.117283E-1
2	3.365604E-1	3.601570E-1	3.814730E-1	66	3.459292E-1	3.685775E-1	3.884733E-1
3	3.105093E-1	3.317324E-1	3.668644E-1	67	3.132197E-1	3.392295E-1	3.875979E-1
4	3.374710E-1	3.967953E-1	4.123563E-1	68	3.514540E-1	3.987303E-1	4.126562E-1
5	2.796604E-1	3.665201E-1	3.853135E-1	69	2.934871E-1	3.757631E-1	3.944881E-1
6	3.160390E-1	3.856093E-1	4.013048E-1	70	3.244708E-1	3.942029E-1	4.088827E-1
7	3.099604E-1	3.434107E-1	4.247455E-1	71	3.127108E-1	3.577203E-1	4.140612E-1
8	3.542436E-1	4.086993E-1	4.221680E-1	72	3.665072E-1	4.081713E-1	4.238914E-1
9	2.955872E-1	3.337411E-1	3.874217E-1	73	2.999657E-1	3.319934E-1	4.078602E-1
10	3.334464E-1	3.869748E-1	4.013531E-1	74	3.349252E-1	3.861430E-1	4.115381E-1
11	3.234128E-1	3.652697E-1	3.851933E-1	75	3.347880E-1	3.661962E-1	3.933471E-1
12	3.427320E-1	4.031925E-1	4.199204E-1	76	3.478479E-1	4.059265E-1	4.305073E-1
13	2.776818E-1	3.824950E-1	4.042742E-1	77	2.859529E-1	3.952833E-1	4.161193E-1
14	3.182480E-1	3.959853E-1	4.313532E-1	78	3.238674E-1	4.064767E-1	4.424828E-1
15	3.037114E-1	3.803197E-1	4.371736E-1	79	3.167167E-1	3.844516E-1	4.394110E-1
16	3.782888E-1	4.070773E-1	4.226791E-1	80	3.867729E-1	4.118246E-1	4.278315E-1
17	2.381165E-1	3.424543E-1	4.246247E-1	81	2.380724E-1	3.623424E-1	4.309317E-1
18	3.456157E-1	3.686811E-1	4.008173E-1	82	3.464500E-1	3.790829E-1	4.065678E-1

3GPP2 C.S0014-C ver 1.0

19	3.176881E-1	3.419027E-1	4.056018E-1	83	3.165766E-1	3.564686E-1	3.962183E-1
20	3.663690E-1	3.890399E-1	4.061545E-1	84	3.665392E-1	3.895909E-1	4.210556E-1
21	2.993980E-1	3.520217E-1	3.999557E-1	85	3.082914E-1	3.713243E-1	4.078674E-1
22	3.249919E-1	3.900288E-1	4.194787E-1	86	3.364352E-1	3.915144E-1	4.229771E-1
23	3.230258E-1	3.681143E-1	4.020878E-1	87	3.230355E-1	3.804473E-1	4.095502E-1
24	3.623263E-1	4.169280E-1	4.327737E-1	88	3.652281E-1	4.279104E-1	4.436913E-1
25	2.726964E-1	3.592050E-1	4.268807E-1	89	2.720380E-1	3.765968E-1	4.336859E-1
26	3.465399E-1	3.696166E-1	4.156212E-1	90	3.576658E-1	3.777616E-1	4.091790E-1
27	3.341091E-1	3.557363E-1	3.967496E-1	91	3.364986E-1	3.642159E-1	4.092555E-1
28	3.374690E-1	4.103927E-1	4.259868E-1	92	3.480824E-1	4.176318E-1	4.332845E-1
29	2.994690E-1	3.806483E-1	4.182841E-1	93	3.027545E-1	3.959748E-1	4.337173E-1
30	3.213782E-1	4.111980E-1	4.287925E-1	94	3.316763E-1	4.175872E-1	4.362398E-1
31	3.278412E-1	3.693451E-1	4.343956E-1	95	3.332876E-1	3.807991E-1	4.396207E-1
32	3.806691E-1	4.260864E-1	4.427546E-1	96	3.881120E-1	4.369336E-1	4.508293E-1
33	2.689437E-1	3.429430E-1	3.986815E-1	97	2.560266E-1	3.480152E-1	4.229226E-1
34	3.381029E-1	3.763388E-1	3.920432E-1	98	3.457740E-1	3.817258E-1	3.967941E-1
35	3.235935E-1	3.487421E-1	3.725520E-1	99	3.256238E-1	3.503919E-1	3.873307E-1
36	3.475508E-1	3.928854E-1	4.211699E-1	100	3.568681E-1	3.985748E-1	4.231772E-1
37	3.041828E-1	3.598167E-1	3.816333E-1	101	3.012262E-1	3.869070E-1	4.033356E-1
38	3.142214E-1	4.021086E-1	4.200853E-1	102	3.281784E-1	4.020902E-1	4.193893E-1
39	3.013066E-1	3.626627E-1	4.292628E-1	103	3.143854E-1	3.690439E-1	4.343753E-1
40	3.717703E-1	3.986964E-1	4.314390E-1	104	3.723211E-1	4.116724E-1	4.405187E-1
41	2.745913E-1	3.355955E-1	4.200797E-1	105	2.904797E-1	3.481219E-1	4.262165E-1
42	3.445408E-1	3.904518E-1	4.064121E-1	106	3.444388E-1	3.826664E-1	4.173211E-1
43	3.252398E-1	3.783445E-1	3.946733E-1	107	3.348668E-1	3.762357E-1	4.044752E-1
44	3.566835E-1	3.905742E-1	4.338511E-1	108	3.590254E-1	4.047219E-1	4.348384E-1
45	2.635013E-1	3.952601E-1	4.231164E-1	109	2.791280E-1	4.111066E-1	4.353606E-1
46	3.375207E-1	3.925635E-1	4.434158E-1	110	3.481255E-1	3.987321E-1	4.469274E-1
47	3.145223E-1	3.809686E-1	4.226764E-1	111	3.270189E-1	3.901073E-1	4.417075E-1
48	3.762351E-1	4.172987E-1	4.314513E-1	112	3.908584E-1	4.198139E-1	4.351535E-1
49	2.618550E-1	3.686461E-1	4.042606E-1	113	2.553193E-1	3.704060E-1	4.321886E-1
50	3.555802E-1	3.779945E-1	3.958682E-1	114	3.546520E-1	3.883327E-1	4.029561E-1
51	3.277428E-1	3.538728E-1	4.110406E-1	115	3.216082E-1	3.544898E-1	4.282998E-1
52	3.629606E-1	3.994670E-1	4.146902E-1	116	3.751635E-1	3.988340E-1	4.141774E-1
53	3.094109E-1	3.737961E-1	3.926725E-1	117	3.119536E-1	3.914307E-1	4.125525E-1
54	3.310163E-1	4.008016E-1	4.317593E-1	118	3.425288E-1	3.963653E-1	4.324974E-1
55	3.235731E-1	3.686196E-1	4.174551E-1	119	3.337444E-1	3.764224E-1	4.205370E-1
56	3.491159E-1	4.268401E-1	4.439140E-1	120	3.535291E-1	4.292311E-1	4.596993E-1
57	2.897386E-1	3.637593E-1	4.105118E-1	121	2.880179E-1	3.780000E-1	4.340117E-1
58	3.552865E-1	3.893313E-1	4.134324E-1	122	3.556835E-1	3.807800E-1	4.231455E-1
59	3.365659E-1	3.602225E-1	4.241790E-1	123	3.443583E-1	3.721849E-1	4.312654E-1
60	3.399327E-1	4.092288E-1	4.401849E-1	124	3.539661E-1	4.141667E-1	4.429413E-1
61	3.008897E-1	4.000811E-1	4.179557E-1	125	3.047702E-1	4.125175E-1	4.341831E-1
62	3.170521E-1	4.222881E-1	4.422296E-1	126	3.359134E-1	4.245908E-1	4.463785E-1
63	3.273368E-1	3.843117E-1	4.302886E-1	127	3.437382E-1	3.847662E-1	4.352714E-1
64	3.989909E-1	4.294984E-1	4.434752E-1	128	4.109413E-1	4.406630E-1	4.521134E-1

1  
2

**Table 9-5 LSP Quantization Table, Rate 1/2, Codebook 1**

$j$	$q_{rate}(1, 1, j)$	$q_{rate}(1, 2, j)$	$q_{rate}(1, 3, j)$	$j$	$q_{rate}(1, 1, j)$	$q_{rate}(1, 2, j)$	$q_{rate}(1, 3, j)$
1	1.352263E-2	1.820813E-2	3.939407E-2	65	2.104905E-2	2.918910E-2	4.600358E-2
2	2.293929E-2	3.578312E-2	1.053529E-1	66	3.648633E-2	4.623870E-2	1.070442E-1
3	2.091065E-2	3.041591E-2	8.939411E-2	67	2.686521E-2	3.929376E-2	8.411799E-2
4	1.889090E-2	3.827222E-2	1.378204E-1	68	2.729040E-2	5.538051E-2	1.415862E-1
5	2.051438E-2	2.854812E-2	7.397622E-2	69	2.484767E-2	3.632777E-2	7.624309E-2
6	4.695103E-2	6.840319E-2	1.091238E-1	70	5.254308E-2	7.757787E-2	1.145680E-1
7	3.155572E-2	5.691400E-2	8.570576E-2	71	4.077414E-2	5.399238E-2	9.076405E-2
8	3.811819E-2	7.777847E-2	1.925329E-1	72	5.730433E-2	7.658031E-2	1.795790E-1
9	2.162972E-2	2.929089E-2	6.250420E-2	73	2.460324E-2	3.414084E-2	6.789908E-2
10	3.114140E-2	5.990793E-2	1.028607E-1	74	4.082201E-2	6.297838E-2	9.951913E-2
11	3.027993E-2	5.350124E-2	7.809258E-2	75	3.830250E-2	5.528575E-2	7.900193E-2
12	6.508462E-2	9.066247E-2	1.428510E-1	76	7.241113E-2	1.019039E-1	1.469796E-1
13	3.273404E-2	5.040278E-2	6.264923E-2	77	3.739022E-2	4.704639E-2	6.546845E-2
14	5.274399E-2	6.225743E-2	1.221983E-1	78	5.273975E-2	6.727704E-2	1.396804E-1
15	3.488404E-2	6.422224E-2	9.160246E-2	79	4.053654E-2	7.050813E-2	9.256686E-2
16	4.889844E-2	1.050580E-1	1.688135E-1	80	4.434253E-2	1.103672E-1	1.996363E-1
17	2.357911E-2	3.210347E-2	5.608996E-2	81	2.549207E-2	3.476040E-2	6.059020E-2
18	2.772528E-2	4.872818E-2	1.012242E-1	82	4.354655E-2	5.323695E-2	1.083260E-1
19	2.743480E-2	4.049659E-2	9.349261E-2	83	2.795998E-2	4.913248E-2	8.842845E-2
20	4.383601E-2	6.032613E-2	1.524009E-1	84	4.980519E-2	8.817289E-2	1.525973E-1
21	2.689949E-2	4.529064E-2	6.498004E-2	85	3.193463E-2	4.621693E-2	6.852064E-2
22	5.160590E-2	6.083122E-2	1.087996E-1	86	5.802463E-2	6.842687E-2	1.150853E-1
23	4.200649E-2	6.118451E-2	8.544740E-2	87	4.339047E-2	6.905756E-2	8.449844E-2
24	7.135027E-2	1.019721E-1	1.746410E-1	88	7.396916E-2	1.192405E-1	1.773402E-1
25	2.889067E-2	4.139644E-2	5.259280E-2	89	3.187675E-2	4.596974E-2	5.723726E-2
26	3.163645E-2	6.635321E-2	1.249503E-1	90	4.508738E-2	5.665094E-2	1.320058E-1
27	4.302895E-2	5.140233E-2	7.968777E-2	91	4.590970E-2	5.455804E-2	8.614233E-2
28	5.709708E-2	1.084445E-1	1.440756E-1	92	7.446858E-2	1.138154E-1	1.615706E-1
29	3.388403E-2	5.047469E-2	7.297654E-2	93	3.975096E-2	4.953595E-2	7.225423E-2
30	6.542657E-2	7.909877E-2	1.155706E-1	94	6.762578E-2	8.310290E-2	1.279901E-1
31	3.854235E-2	7.331254E-2	1.023075E-1	95	5.762581E-2	6.953264E-2	1.050130E-1
32	6.578245E-2	1.029098E-1	2.118744E-1	96	6.853135E-2	1.217588E-1	2.206266E-1
33	1.547279E-2	2.045597E-2	5.461213E-2	97	2.184805E-2	2.991309E-2	5.162080E-2
34	2.279502E-2	3.909542E-2	1.194438E-1	98	3.643432E-2	4.917951E-2	1.232772E-1
35	3.068892E-2	4.545402E-2	8.204189E-2	99	3.896113E-2	4.766350E-2	8.617166E-2
36	2.259572E-2	4.791017E-2	1.718444E-1	100	4.146352E-2	6.880070E-2	1.693562E-1
37	2.710880E-2	4.017396E-2	7.019229E-2	101	3.355146E-2	4.178152E-2	7.371594E-2
38	4.957894E-2	7.929633E-2	1.048625E-1	102	5.802247E-2	8.703142E-2	1.129175E-1
39	3.060959E-2	5.640594E-2	9.495841E-2	103	4.802431E-2	5.694865E-2	1.007557E-1
40	6.342246E-2	9.116555E-2	1.847244E-1	104	5.988731E-2	8.579423E-2	2.013889E-1
41	2.433424E-2	3.919983E-2	6.314062E-2	105	2.993100E-2	3.948284E-2	6.463761E-2
42	3.380120E-2	6.608465E-2	1.110315E-1	106	3.886266E-2	8.074436E-2	1.155198E-1
43	3.517841E-2	5.793973E-2	7.207029E-2	107	3.494440E-2	6.289110E-2	8.049820E-2
44	6.490541E-2	8.658319E-2	1.546487E-1	108	6.888179E-2	9.924311E-2	1.603933E-1

45	2.919347E-2	5.162046E-2	6.944373E-2	109	3.642377E-2	5.340165E-2	6.701520E-2
46	5.945228E-2	7.198293E-2	1.274345E-1	110	5.834927E-2	7.852858E-2	1.417467E-1
47	5.318885E-2	6.381821E-2	9.882185E-2	111	4.864696E-2	7.267369E-2	9.483159E-2
48	8.682910E-2	1.411354E-1	1.917285E-1	112	5.855336E-2	1.362898E-1	1.986397E-1
49	2.499911E-2	3.625560E-2	5.037240E-2	113	2.608885E-2	3.734068E-2	5.578532E-2
50	2.822464E-2	5.445723E-2	1.126635E-1	114	4.585044E-2	5.605125E-2	1.179279E-1
51	3.626181E-2	4.590732E-2	9.433436E-2	115	4.288013E-2	5.147391E-2	9.753090E-2
52	5.704553E-2	7.463004E-2	1.591572E-1	116	6.376116E-2	8.735529E-2	1.683349E-1
53	2.729875E-2	4.566259E-2	7.525297E-2	117	3.767099E-2	4.582160E-2	7.865281E-2
54	5.128602E-2	8.511270E-2	1.235880E-1	118	6.751946E-2	8.986979E-2	1.194181E-1
55	4.914520E-2	5.934831E-2	9.226860E-2	119	5.463743E-2	6.668059E-2	8.938138E-2
56	7.069619E-2	1.054520E-1	1.926021E-1	120	7.730866E-2	1.217544E-1	1.995792E-1
57	2.807338E-2	4.185092E-2	5.871598E-2	121	3.156213E-2	4.517022E-2	6.257685E-2
58	4.644490E-2	7.066988E-2	1.260384E-1	122	3.787827E-2	8.034865E-2	1.389617E-1
59	4.184537E-2	6.304453E-2	7.661699E-2	123	5.083033E-2	6.187406E-2	8.311538E-2
60	8.424164E-2	1.132829E-1	1.436871E-1	124	8.963114E-2	1.287538E-1	1.648916E-1
61	4.176156E-2	5.594729E-2	7.098728E-2	125	4.735035E-2	5.757244E-2	7.652646E-2
62	5.551614E-2	9.501267E-2	1.277272E-1	126	7.168986E-2	9.898957E-2	1.300784E-1
63	5.909355E-2	7.367300E-2	9.659359E-2	127	6.290826E-2	7.907788E-2	1.051111E-1
64	7.841367E-2	1.414324E-1	2.174286E-1	128	8.806498E-2	1.652062E-1	2.132142E-1

1  
2

Table 9-6 LSP Quantization Table, Rate 1/2, Codebook 2

$j$	$q_{rate}(2, 1, j)$	$q_{rate}(2, 2, j)$	$q_{rate}(2, 3, j)$	$j$	$q_{rate}(2, 1, j)$	$q_{rate}(2, 2, j)$	$q_{rate}(2, 3, j)$
1	9.759153E-2	1.237015E-1	1.694380E-1	65	1.140764E-1	1.330714E-1	1.731815E-1
2	9.495363E-2	2.010818E-1	2.268553E-1	66	1.135758E-1	1.903073E-1	2.416812E-1
3	9.004966E-2	1.491649E-1	2.265328E-1	67	8.591653E-2	1.639202E-1	2.379345E-1
4	1.703027E-1	1.972229E-1	2.499748E-1	68	1.929169E-1	2.150824E-1	2.391281E-1
5	1.087736E-1	1.519724E-1	1.751234E-1	69	1.372918E-1	1.594233E-1	1.797222E-1
6	1.302789E-1	2.132292E-1	2.296464E-1	70	1.404354E-1	2.220923E-1	2.409608E-1
7	1.249180E-1	1.873478E-1	2.047120E-1	71	1.403872E-1	1.896012E-1	2.056357E-1
8	2.006702E-1	2.289636E-1	2.694208E-1	72	2.116955E-1	2.365784E-1	2.812489E-1
9	8.983756E-2	1.253328E-1	2.105394E-1	73	9.030106E-2	1.271574E-1	2.335679E-1
10	9.623767E-2	2.071859E-1	2.541745E-1	74	1.101181E-1	2.093284E-1	2.728363E-1
11	1.056946E-1	1.788564E-1	2.001210E-1	75	1.167104E-1	1.778540E-1	2.228088E-1
12	1.560490E-1	2.195737E-1	2.910794E-1	76	1.816915E-1	2.322652E-1	2.749912E-1
13	1.373923E-1	1.599933E-1	1.946985E-1	77	1.465535E-1	1.694747E-1	1.902460E-1
14	1.072625E-1	2.377910E-1	2.707408E-1	78	1.092138E-1	2.632920E-1	2.884908E-1
15	1.429765E-1	2.015505E-1	2.184689E-1	79	1.498151E-1	2.113427E-1	2.288995E-1
16	2.142705E-1	2.718814E-1	3.012002E-1	80	1.976455E-1	2.832300E-1	3.148823E-1
17	1.107292E-1	1.336882E-1	1.548772E-1	81	1.244956E-1	1.460980E-1	1.661252E-1
18	1.066677E-1	1.766788E-1	2.627989E-1	82	1.348786E-1	1.830301E-1	2.892883E-1
19	9.163529E-2	1.745928E-1	2.193293E-1	83	9.330321E-2	1.839622E-1	2.385430E-1
20	1.840386E-1	2.279641E-1	2.477622E-1	84	1.928443E-1	2.395883E-1	2.584215E-1
21	1.105724E-1	1.582072E-1	1.960131E-1	85	1.237968E-1	1.655566E-1	2.084084E-1
22	1.335434E-1	2.322697E-1	2.518282E-1	86	1.511443E-1	2.358011E-1	2.592806E-1
23	1.559223E-1	1.779413E-1	2.180966E-1	87	1.506577E-1	1.900525E-1	2.283626E-1
24	1.922601E-1	2.495125E-1	2.899115E-1	88	1.981810E-1	2.567942E-1	3.089756E-1

25	1.137089E-1	1.378724E-1	2.029299E-1	89	1.284900E-1	1.490840E-1	1.983765E-1
26	1.025575E-1	1.848201E-1	2.921646E-1	90	9.205958E-2	2.122313E-1	2.929488E-1
27	1.365956E-1	1.586874E-1	2.413996E-1	91	1.416981E-1	1.723567E-1	2.584541E-1
28	1.728138E-1	2.493034E-1	3.004586E-1	92	1.967335E-1	2.297097E-1	2.957802E-1
29	1.368712E-1	1.572498E-1	2.109132E-1	93	1.470622E-1	1.689181E-1	2.073636E-1
30	1.289748E-1	2.451679E-1	2.676536E-1	94	1.363099E-1	2.603731E-1	2.826074E-1
31	1.668123E-1	1.889980E-1	2.313459E-1	95	1.810411E-1	2.018261E-1	2.388676E-1
32	2.322485E-1	2.631961E-1	3.167549E-1	96	2.453263E-1	2.801831E-1	3.119543E-1
33	9.245610E-2	1.199775E-1	1.912623E-1	97	1.041318E-1	1.330407E-1	1.898347E-1
34	1.130853E-1	2.084615E-1	2.293681E-1	98	1.232982E-1	2.096211E-1	2.478132E-1
35	1.007164E-1	1.406701E-1	2.580630E-1	99	1.240408E-1	1.598274E-1	2.588561E-1
36	1.670104E-1	2.181055E-1	2.625925E-1	100	1.870489E-1	2.124881E-1	2.596291E-1
37	1.254872E-1	1.626870E-1	1.844092E-1	101	1.242553E-1	1.737690E-1	1.928500E-1
38	1.524066E-1	2.071317E-1	2.475824E-1	102	1.589178E-1	2.253898E-1	2.432848E-1
39	1.374412E-1	1.802624E-1	2.176988E-1	103	1.534212E-1	1.918073E-1	2.092495E-1
40	2.078535E-1	2.492095E-1	2.698301E-1	104	2.271545E-1	2.511812E-1	2.726004E-1
41	9.352573E-2	1.491974E-1	2.046520E-1	105	1.099221E-1	1.571003E-1	2.200250E-1
42	1.119972E-1	2.252331E-1	2.470031E-1	106	1.327824E-1	2.194855E-1	2.670289E-1
43	1.093150E-1	1.938119E-1	2.138022E-1	107	1.268575E-1	1.988363E-1	2.179285E-1
44	1.751186E-1	2.525203E-1	2.750828E-1	108	1.914150E-1	2.524242E-1	2.726528E-1
45	1.369187E-1	1.774406E-1	1.979311E-1	109	1.552776E-1	1.795735E-1	2.007736E-1
46	1.368112E-1	2.374262E-1	2.847378E-1	110	1.175477E-1	2.478699E-1	3.082793E-1
47	1.607598E-1	2.008332E-1	2.180845E-1	111	1.657070E-1	2.103395E-1	2.291993E-1
48	2.337102E-1	2.663726E-1	2.918021E-1	112	2.256949E-1	2.844382E-1	3.121061E-1
49	1.191711E-1	1.397032E-1	1.877233E-1	113	1.295032E-1	1.484201E-1	1.801804E-1
50	1.310500E-1	1.936967E-1	2.604270E-1	114	1.547525E-1	1.977485E-1	2.672750E-1
51	1.082671E-1	1.651948E-1	2.395230E-1	115	1.285902E-1	1.761784E-1	2.399059E-1
52	2.031950E-1	2.259422E-1	2.494032E-1	116	2.149268E-1	2.376344E-1	2.587940E-1
53	1.238429E-1	1.457946E-1	2.156356E-1	117	1.283223E-1	1.593385E-1	2.266266E-1
54	1.712263E-1	2.380545E-1	2.579756E-1	118	1.557476E-1	2.477405E-1	2.737268E-1
55	1.669238E-1	1.886047E-1	2.111242E-1	119	1.757417E-1	1.979524E-1	2.191159E-1
56	2.106208E-1	2.624427E-1	2.831280E-1	120	2.186264E-1	2.458092E-1	3.004797E-1
57	1.057488E-1	1.362865E-1	2.200502E-1	121	1.177090E-1	1.455129E-1	2.380445E-1
58	9.729458E-2	2.334715E-1	2.961140E-1	122	1.180069E-1	2.237755E-1	2.941751E-1
59	1.342984E-1	1.939554E-1	2.391488E-1	123	1.513492E-1	1.881578E-1	2.487433E-1
60	1.642293E-1	2.700678E-1	2.941425E-1	124	1.893122E-1	2.695805E-1	2.937860E-1
61	1.427603E-1	1.650334E-1	2.241004E-1	125	1.498956E-1	1.745373E-1	2.374300E-1
62	1.464145E-1	2.479423E-1	3.007081E-1	126	1.397755E-1	2.717094E-1	3.078395E-1
63	1.747788E-1	2.193493E-1	2.381630E-1	127	1.839457E-1	2.077172E-1	2.267222E-1
64	2.363111E-1	2.906697E-1	3.280110E-1	128	2.545522E-1	2.966409E-1	3.248015E-1

1  
2

**Table 9-7 LSP Quantization Table, Rate 1/2, Codebook 3**

$j$	$q_{rate}(3, 1, j)$	$q_{rate}(3, 2, j)$	$q_{rate}(3, 3, j)$	$q_{rate}(3, 4, j)$
1	2.369047E-1	2.561044E-1	3.169558E-1	4.075205E-1
2	2.975969E-1	3.234825E-1	3.476675E-1	3.745512E-1
3	2.737212E-1	2.982975E-1	3.299239E-1	3.835991E-1
4	3.078496E-1	3.328363E-1	3.893403E-1	4.055760E-1

5	2.338036E-1	2.602965E-1	3.673520E-1	4.043883E-1
6	2.975137E-1	3.153566E-1	3.851352E-1	4.021971E-1
7	2.856188E-1	3.108728E-1	3.650224E-1	3.848168E-1
8	3.352716E-1	3.552222E-1	3.819211E-1	3.986858E-1
9	2.002656E-1	2.505023E-1	3.703982E-1	4.320127E-1
10	3.079821E-1	3.337677E-1	3.581991E-1	3.783868E-1
11	2.600861E-1	3.255203E-1	3.568733E-1	3.847378E-1
12	3.013564E-1	3.413694E-1	4.002968E-1	4.173372E-1
13	2.670810E-1	2.976744E-1	3.697020E-1	3.891392E-1
14	2.726699E-1	3.497041E-1	3.919253E-1	4.063833E-1
15	2.528259E-1	3.496366E-1	3.845510E-1	4.059310E-1
16	3.429271E-1	3.742740E-1	4.054682E-1	4.203519E-1
17	2.524087E-1	2.803758E-1	3.214366E-1	3.884369E-1
18	2.969702E-1	3.171736E-1	3.653426E-1	4.027368E-1
19	2.819052E-1	3.014792E-1	3.343356E-1	4.076335E-1
20	3.268729E-1	3.471777E-1	3.750177E-1	4.053724E-1
21	2.363711E-1	3.164411E-1	3.487070E-1	3.820304E-1
22	2.878176E-1	3.136270E-1	4.051297E-1	4.233797E-1
23	2.775025E-1	3.018438E-1	3.722509E-1	4.192128E-1
24	3.289889E-1	3.619011E-1	4.020155E-1	4.192298E-1
25	2.249605E-1	2.746364E-1	3.770161E-1	3.947265E-1
26	3.010455E-1	3.404862E-1	3.748881E-1	4.025322E-1
27	2.598980E-1	3.303350E-1	3.574938E-1	4.086580E-1
28	3.009619E-1	3.564491E-1	4.047795E-1	4.225090E-1
29	2.209796E-1	3.164777E-1	4.017441E-1	4.207358E-1
30	2.797550E-1	3.307761E-1	4.111529E-1	4.326870E-1
31	2.642469E-1	3.166106E-1	3.838767E-1	4.366838E-1
32	3.443812E-1	3.853657E-1	4.249495E-1	4.415602E-1
33	2.194883E-1	2.364599E-1	3.424660E-1	4.249900E-1
34	2.914651E-1	3.222820E-1	3.728528E-1	3.916359E-1
35	2.747924E-1	3.165363E-1	3.453926E-1	3.745552E-1
36	3.105835E-1	3.352649E-1	3.875272E-1	4.230762E-1
37	2.232115E-1	2.984976E-1	3.684262E-1	3.902137E-1
38	2.890788E-1	3.265128E-1	3.763087E-1	4.095537E-1
39	2.638301E-1	3.089773E-1	3.814530E-1	4.046608E-1
40	3.470736E-1	3.647978E-1	3.867635E-1	4.045117E-1
41	2.184527E-1	2.756141E-1	3.627111E-1	4.182790E-1
42	3.150428E-1	3.408132E-1	3.786272E-1	3.963168E-1
43	2.797277E-1	3.312597E-1	3.600613E-1	3.811755E-1
44	3.186024E-1	3.380443E-1	4.090108E-1	4.303004E-1
45	2.641969E-1	2.906725E-1	3.685950E-1	4.318568E-1
46	2.726456E-1	3.635148E-1	3.965188E-1	4.200912E-1
47	2.265410E-1	3.500551E-1	3.938515E-1	4.125970E-1
48	3.530539E-1	3.699296E-1	4.096561E-1	4.263873E-1
49	2.607884E-1	2.851725E-1	3.459433E-1	3.975007E-1
50	3.011131E-1	3.282019E-1	3.560680E-1	4.108038E-1
51	2.881016E-1	3.095596E-1	3.437568E-1	4.248729E-1
52	3.104894E-1	3.514219E-1	3.937174E-1	4.155505E-1

53	2.223083E-1	3.267982E-1	3.779817E-1	3.986350E-1
54	3.029155E-1	3.227819E-1	3.985589E-1	4.254896E-1
55	2.771368E-1	3.199926E-1	3.774909E-1	4.291775E-1
56	3.387318E-1	3.581644E-1	4.083864E-1	4.254954E-1
57	2.187262E-1	2.843850E-1	3.940537E-1	4.163470E-1
58	3.010060E-1	3.440937E-1	3.690137E-1	4.150913E-1
59	2.807837E-1	3.330537E-1	3.767262E-1	3.975269E-1
60	3.143941E-1	3.626788E-1	4.236690E-1	4.418992E-1
61	2.664536E-1	3.085138E-1	3.974072E-1	4.174502E-1
62	2.942227E-1	3.419044E-1	4.127269E-1	4.348889E-1
63	2.873007E-1	3.324346E-1	3.788567E-1	4.382340E-1
64	3.571466E-1	3.981471E-1	4.298757E-1	4.442439E-1
65	2.296713E-1	2.510186E-1	3.410466E-1	4.043763E-1
66	2.944726E-1	3.349446E-1	3.604097E-1	3.836829E-1
67	2.882510E-1	3.117227E-1	3.316801E-1	3.651047E-1
68	3.248816E-1	3.456567E-1	3.883064E-1	4.059549E-1
69	2.508292E-1	2.776235E-1	3.707995E-1	3.904792E-1
70	2.935234E-1	3.283192E-1	3.921123E-1	4.094641E-1
71	2.836088E-1	3.038856E-1	3.785044E-1	3.973106E-1
72	3.340398E-1	3.528374E-1	3.972729E-1	4.143220E-1
73	2.218919E-1	2.518775E-1	3.717235E-1	4.317910E-1
74	3.132014E-1	3.411754E-1	3.655036E-1	3.885672E-1
75	2.713305E-1	3.391637E-1	3.626164E-1	3.957360E-1
76	3.075501E-1	3.477777E-1	4.010496E-1	4.327675E-1
77	2.593874E-1	2.872438E-1	3.868173E-1	4.060427E-1
78	2.854852E-1	3.440950E-1	4.020505E-1	4.194138E-1
79	2.657814E-1	3.400844E-1	3.694077E-1	4.270317E-1
80	3.537409E-1	3.844633E-1	4.117478E-1	4.261818E-1
81	2.438665E-1	2.683502E-1	3.422020E-1	3.984572E-1
82	2.931452E-1	3.347542E-1	3.617028E-1	3.984166E-1
83	2.913430E-1	3.131552E-1	3.365259E-1	3.877486E-1
84	3.056568E-1	3.629046E-1	3.881534E-1	4.055432E-1
85	2.174923E-1	3.117235E-1	3.759848E-1	4.289978E-1
86	2.911493E-1	3.293809E-1	4.039004E-1	4.223332E-1
87	2.903621E-1	3.095310E-1	3.789942E-1	4.136884E-1
88	3.295649E-1	3.774047E-1	4.065849E-1	4.247397E-1
89	2.464616E-1	2.715933E-1	3.663383E-1	4.307538E-1
90	3.141077E-1	3.370119E-1	3.804097E-1	4.110994E-1
91	2.765684E-1	3.273207E-1	3.588443E-1	4.289495E-1
92	3.171791E-1	3.589724E-1	4.047658E-1	4.403763E-1
93	2.427778E-1	3.349548E-1	3.969435E-1	4.133184E-1
94	2.888955E-1	3.256912E-1	4.228596E-1	4.437587E-1
95	2.775833E-1	3.254790E-1	3.891447E-1	4.410759E-1
96	3.591257E-1	3.906941E-1	4.210095E-1	4.357085E-1
97	2.201724E-1	2.477193E-1	3.543819E-1	4.253981E-1
98	3.060468E-1	3.279247E-1	3.669928E-1	3.931926E-1
99	2.708056E-1	3.168266E-1	3.456487E-1	4.117176E-1
100	3.231889E-1	3.454631E-1	3.897788E-1	4.215708E-1

101	2.461361E-1	3.123920E-1	3.721886E-1	3.958427E-1
102	3.038567E-1	3.243548E-1	3.857473E-1	4.141550E-1
103	2.810754E-1	3.186085E-1	3.856469E-1	4.027036E-1
104	3.535171E-1	3.727025E-1	3.962646E-1	4.130749E-1
105	2.092211E-1	2.952622E-1	3.803143E-1	4.312782E-1
106	3.253136E-1	3.467355E-1	3.707240E-1	3.910456E-1
107	2.863965E-1	3.435600E-1	3.697136E-1	3.898678E-1
108	3.277947E-1	3.473678E-1	4.054651E-1	4.245662E-1
109	2.530550E-1	3.026563E-1	3.821651E-1	4.298983E-1
110	2.944185E-1	3.707454E-1	3.954433E-1	4.195148E-1
111	2.628731E-1	3.450692E-1	4.041409E-1	4.219021E-1
112	3.650635E-1	3.824351E-1	4.134248E-1	4.312417E-1
113	2.487885E-1	2.823728E-1	3.657723E-1	4.109811E-1
114	3.072888E-1	3.278289E-1	3.776650E-1	4.362209E-1
115	2.985423E-1	3.206273E-1	3.505697E-1	4.276202E-1
116	3.162580E-1	3.629038E-1	3.882251E-1	4.256089E-1
117	2.390779E-1	3.313105E-1	3.703179E-1	4.159959E-1
118	3.037358E-1	3.328061E-1	4.102328E-1	4.277511E-1
119	2.960025E-1	3.190148E-1	3.810625E-1	4.269550E-1
120	3.325089E-1	3.625170E-1	4.233151E-1	4.409952E-1
121	2.351287E-1	2.747311E-1	4.120706E-1	4.354788E-1
122	2.980738E-1	3.553388E-1	3.790878E-1	4.153188E-1
123	2.834298E-1	3.452649E-1	3.703763E-1	4.099008E-1
124	3.235931E-1	3.654128E-1	4.128131E-1	4.310235E-1
125	2.766264E-1	3.005084E-1	4.022369E-1	4.266388E-1
126	2.945129E-1	3.614432E-1	4.196352E-1	4.369992E-1
127	2.908073E-1	3.416894E-1	3.927793E-1	4.434903E-1
128	3.593915E-1	4.039851E-1	4.408438E-1	4.530286E-1
129	2.232955E-1	2.391925E-1	3.237680E-1	4.216895E-1
130	2.947781E-1	3.187987E-1	3.532178E-1	3.919064E-1
131	2.590321E-1	3.102405E-1	3.435690E-1	3.950642E-1
132	3.164747E-1	3.385444E-1	3.933290E-1	4.122356E-1
133	2.401082E-1	2.846312E-1	3.602810E-1	3.799738E-1
134	2.969091E-1	3.157983E-1	3.949643E-1	4.151276E-1
135	2.854341E-1	3.049215E-1	3.619747E-1	4.057673E-1
136	3.374071E-1	3.566722E-1	3.851551E-1	4.111867E-1
137	2.240149E-1	2.601162E-1	3.947725E-1	4.195859E-1
138	3.006479E-1	3.416407E-1	3.702235E-1	3.895201E-1
139	2.659460E-1	3.250392E-1	3.743399E-1	3.923461E-1
140	3.160293E-1	3.404913E-1	4.023553E-1	4.204842E-1
141	2.698415E-1	2.945624E-1	3.623418E-1	4.064155E-1
142	2.788973E-1	3.598310E-1	3.820258E-1	4.105775E-1
143	2.607608E-1	3.310885E-1	3.888263E-1	4.054866E-1
144	3.433723E-1	3.826470E-1	4.147166E-1	4.315929E-1
145	2.479981E-1	2.733932E-1	3.311604E-1	4.189432E-1
146	3.035796E-1	3.252025E-1	3.709844E-1	4.144205E-1
147	2.768969E-1	3.004995E-1	3.541782E-1	4.288070E-1
148	3.236556E-1	3.598170E-1	3.895254E-1	4.092887E-1

149	2.389278E-1	3.099192E-1	3.539156E-1	4.166343E-1
150	2.811717E-1	3.075203E-1	4.162649E-1	4.385238E-1
151	2.888587E-1	3.098108E-1	3.678452E-1	4.360356E-1
152	3.384235E-1	3.706344E-1	4.154500E-1	4.315345E-1
153	2.412604E-1	2.736179E-1	3.895546E-1	4.125395E-1
154	2.980467E-1	3.401221E-1	3.861837E-1	4.138264E-1
155	2.824364E-1	3.315975E-1	3.579414E-1	4.121152E-1
156	3.038202E-1	3.705886E-1	4.057750E-1	4.315171E-1
157	2.390777E-1	3.116385E-1	4.139358E-1	4.353041E-1
158	2.671168E-1	3.419379E-1	4.174094E-1	4.391848E-1
159	2.679468E-1	3.333439E-1	3.864814E-1	4.374625E-1
160	3.405110E-1	3.908780E-1	4.354851E-1	4.491019E-1
161	2.100699E-1	2.325245E-1	3.617814E-1	4.313579E-1
162	2.945099E-1	3.337098E-1	3.822786E-1	3.986389E-1
163	2.805252E-1	3.259052E-1	3.506470E-1	3.928739E-1
164	3.199996E-1	3.436747E-1	3.910705E-1	4.375011E-1
165	2.205810E-1	3.031519E-1	3.817655E-1	4.044882E-1
166	2.861227E-1	3.297465E-1	3.881028E-1	4.242477E-1
167	2.698071E-1	3.253323E-1	3.791545E-1	4.151382E-1
168	3.348589E-1	3.692584E-1	3.947431E-1	4.119222E-1
169	2.071098E-1	2.727795E-1	3.785664E-1	4.345800E-1
170	3.064662E-1	3.466957E-1	3.871383E-1	4.035583E-1
171	2.701486E-1	3.466545E-1	3.776967E-1	3.964345E-1
172	3.187459E-1	3.402257E-1	4.149916E-1	4.415788E-1
173	2.585928E-1	3.143701E-1	3.650838E-1	4.216152E-1
174	2.827130E-1	3.541371E-1	4.067460E-1	4.292679E-1
175	2.520218E-1	3.591051E-1	3.951029E-1	4.181484E-1
176	3.549062E-1	3.749529E-1	4.189660E-1	4.361444E-1
177	2.648411E-1	2.929418E-1	3.277515E-1	4.087905E-1
178	3.077743E-1	3.355862E-1	3.622096E-1	4.253942E-1
179	2.884663E-1	3.160757E-1	3.609896E-1	4.195514E-1
180	3.171284E-1	3.557722E-1	4.058088E-1	4.239730E-1
181	2.470897E-1	3.381846E-1	3.718596E-1	3.959715E-1
182	3.079817E-1	3.326918E-1	4.005342E-1	4.382737E-1
183	2.794848E-1	3.161835E-1	3.972377E-1	4.347466E-1
184	3.444905E-1	3.661532E-1	4.109594E-1	4.417271E-1
185	2.357418E-1	2.945873E-1	3.980725E-1	4.168334E-1
186	3.140385E-1	3.522720E-1	3.791389E-1	4.109691E-1
187	2.830025E-1	3.381363E-1	3.886419E-1	4.061933E-1
188	3.236253E-1	3.502434E-1	4.280896E-1	4.466304E-1
189	2.612521E-1	3.249710E-1	4.002145E-1	4.253218E-1
190	3.052845E-1	3.421642E-1	4.244751E-1	4.438310E-1
191	2.873748E-1	3.325006E-1	3.943083E-1	4.425385E-1
192	3.740754E-1	4.020264E-1	4.309335E-1	4.441600E-1
193	2.345040E-1	2.562186E-1	3.412388E-1	4.230453E-1
194	3.054926E-1	3.291570E-1	3.527098E-1	3.924391E-1
195	2.813236E-1	3.032923E-1	3.489254E-1	3.931639E-1
196	3.218935E-1	3.504199E-1	3.973175E-1	4.145603E-1

197	2.396846E-1	2.924515E-1	3.789374E-1	3.965355E-1
198	3.073072E-1	3.291279E-1	3.984556E-1	4.161433E-1
199	2.852746E-1	3.087745E-1	3.929165E-1	4.144377E-1
200	3.444464E-1	3.622019E-1	3.976198E-1	4.177436E-1
201	2.320831E-1	2.678080E-1	3.780757E-1	4.345609E-1
202	3.047387E-1	3.518653E-1	3.759732E-1	3.952937E-1
203	2.619909E-1	3.462073E-1	3.712969E-1	4.124389E-1
204	3.110809E-1	3.510409E-1	4.160828E-1	4.343401E-1
205	2.749804E-1	2.966315E-1	3.875205E-1	4.092438E-1
206	2.909391E-1	3.544556E-1	3.934270E-1	4.082203E-1
207	2.718719E-1	3.455108E-1	3.871253E-1	4.225906E-1
208	3.632459E-1	3.819322E-1	4.041149E-1	4.183707E-1
209	2.457707E-1	2.729093E-1	3.483179E-1	4.251618E-1
210	3.141390E-1	3.378723E-1	3.651952E-1	4.044234E-1
211	2.940758E-1	3.169355E-1	3.430472E-1	4.061304E-1
212	3.146275E-1	3.724134E-1	4.006607E-1	4.179308E-1
213	2.340142E-1	3.140072E-1	3.830035E-1	4.348292E-1
214	2.936357E-1	3.205300E-1	4.108374E-1	4.363931E-1
215	2.895058E-1	3.118289E-1	3.863115E-1	4.387713E-1
216	3.263174E-1	3.808582E-1	4.197214E-1	4.387955E-1
217	2.508095E-1	2.830181E-1	3.822474E-1	4.342444E-1
218	3.189941E-1	3.448551E-1	3.726901E-1	4.230670E-1
219	2.883801E-1	3.366222E-1	3.697423E-1	4.250576E-1
220	3.061077E-1	3.818569E-1	4.182062E-1	4.328684E-1
221	2.338983E-1	3.448618E-1	4.121766E-1	4.292162E-1
222	2.859809E-1	3.429038E-1	4.251129E-1	4.442997E-1
223	2.798588E-1	3.387893E-1	3.920854E-1	4.405410E-1
224	3.645093E-1	3.822027E-1	4.298306E-1	4.458184E-1
225	2.343923E-1	2.573774E-1	3.595671E-1	4.300886E-1
226	3.050319E-1	3.275894E-1	3.783056E-1	4.010261E-1
227	2.775226E-1	3.181303E-1	3.677943E-1	4.015430E-1
228	3.330358E-1	3.558210E-1	3.875489E-1	4.246287E-1
229	2.450210E-1	3.125607E-1	3.911476E-1	4.087628E-1
230	2.970591E-1	3.402469E-1	3.929193E-1	4.288997E-1
231	2.778393E-1	3.250198E-1	3.974364E-1	4.159209E-1
232	3.494653E-1	3.703625E-1	3.954825E-1	4.319234E-1
233	2.314856E-1	2.910234E-1	3.779095E-1	4.322597E-1
234	3.192835E-1	3.536711E-1	3.809829E-1	3.978434E-1
235	2.896892E-1	3.502657E-1	3.807297E-1	3.979694E-1
236	3.289873E-1	3.520054E-1	4.125572E-1	4.375979E-1
237	2.762733E-1	3.022672E-1	3.817234E-1	4.349891E-1
238	2.796273E-1	3.737273E-1	4.123746E-1	4.306263E-1
239	2.534428E-1	3.659400E-1	4.149370E-1	4.327436E-1
240	3.761072E-1	3.951420E-1	4.167877E-1	4.330236E-1
241	2.628158E-1	2.882705E-1	3.473972E-1	4.241826E-1
242	3.019313E-1	3.436526E-1	3.770313E-1	4.342045E-1
243	2.978343E-1	3.234954E-1	3.644924E-1	4.335508E-1
244	3.317745E-1	3.643249E-1	3.982436E-1	4.350783E-1

245	2.490497E-1	3.278708E-1	3.835870E-1	4.355581E-1
246	3.046534E-1	3.276712E-1	4.184847E-1	4.413788E-1
247	2.969609E-1	3.238989E-1	3.904637E-1	4.399160E-1
248	3.439238E-1	3.671005E-1	4.295232E-1	4.452150E-1
249	2.593997E-1	2.916027E-1	4.043725E-1	4.314132E-1
250	2.975375E-1	3.575738E-1	3.889918E-1	4.300070E-1
251	2.840689E-1	3.495746E-1	3.810428E-1	4.297128E-1
252	3.257163E-1	3.748759E-1	4.319593E-1	4.472908E-1
253	2.653030E-1	3.147460E-1	4.167035E-1	4.372947E-1
254	3.003986E-1	3.541473E-1	4.285381E-1	4.603364E-1
255	2.980772E-1	3.493049E-1	4.004293E-1	4.482135E-1
256	3.755762E-1	4.166573E-1	4.421368E-1	4.527286E-1

1  
2

**Table 9-8 LSP Quantization Table, Rate 1/8, Codebook 1**

$j$	$q_{rate}(1, 1, j)$	$q_{rate}(1, 2, j)$	$q_{rate}(1, 3, j)$	$q_{rate}(1, 4, j)$	$q_{rate}(1, 5, j)$
1	4.209106E-2	6.947497E-2	1.116895E-1	1.457197E-1	2.089358E-1
2	5.494466E-2	9.824226E-2	1.100788E-1	1.589078E-1	2.054824E-1
3	4.518857E-2	7.519943E-2	1.142339E-1	1.546973E-1	1.974671E-1
4	4.947500E-2	7.966750E-2	1.257135E-1	1.694478E-1	2.077532E-1
5	4.178938E-2	6.345956E-2	1.206803E-1	1.585077E-1	2.040682E-1
6	4.715924E-2	7.912955E-2	1.218311E-1	1.565005E-1	2.230923E-1
7	5.453992E-2	8.034305E-2	1.294776E-1	1.518615E-1	2.017172E-1
8	5.585208E-2	9.411485E-2	1.401603E-1	1.780708E-1	2.295549E-1
9	4.544353E-2	7.354141E-2	1.193766E-1	1.544203E-1	2.101075E-1
10	6.317801E-2	9.523149E-2	1.236498E-1	1.767254E-1	2.174373E-1
11	5.276537E-2	8.435144E-2	1.158909E-1	1.579092E-1	2.073235E-1
12	5.186575E-2	8.132854E-2	1.375623E-1	1.832288E-1	2.164007E-1
13	4.441953E-2	6.887446E-2	1.311525E-1	1.626358E-1	2.165910E-1
14	4.937844E-2	8.188255E-2	1.306717E-1	1.682190E-1	2.313608E-1
15	5.590978E-2	9.078330E-2	1.334885E-1	1.629847E-1	2.096152E-1
16	6.137821E-2	9.860277E-2	1.479333E-1	1.928319E-1	2.315651E-1

3  
4

**Table 9-9 LSP Quantization Table, Rate 1/8, Codebook 2**

$j$	$q_{rate}(2, 1, j)$	$q_{rate}(2, 2, j)$	$q_{rate}(2, 3, j)$	$q_{rate}(2, 4, j)$	$q_{rate}(2, 5, j)$
1	2.682296E-1	3.058530E-1	3.111035E-1	3.682334E-1	4.077447E-1
2	2.441801E-1	2.897017E-1	3.257376E-1	3.902148E-1	4.134584E-1
3	2.334183E-1	3.007829E-1	3.289390E-1	3.855733E-1	4.106846E-1
4	2.590587E-1	2.975686E-1	3.419662E-1	3.853117E-1	4.129523E-1
5	2.429045E-1	2.922362E-1	3.271855E-1	3.778814E-1	4.033293E-1
6	2.467419E-1	2.974937E-1	3.363123E-1	3.942606E-1	4.225895E-1
7	2.137760E-1	3.314042E-1	3.406769E-1	3.822208E-1	4.093902E-1
8	2.667348E-1	3.079165E-1	3.441972E-1	3.961151E-1	4.238752E-1
9	2.612143E-1	3.049254E-1	3.299724E-1	3.848680E-1	4.202374E-1
10	2.495487E-1	2.937286E-1	3.338274E-1	3.785067E-1	4.171406E-1
11	2.415889E-1	3.017342E-1	3.412825E-1	3.842858E-1	4.161965E-1
12	2.581891E-1	3.173641E-1	3.490434E-1	3.876993E-1	4.155136E-1

13	2.445059E-1	3.067345E-1	3.357932E-1	3.784443E-1	4.055705E-1
14	2.516403E-1	3.122508E-1	3.384779E-1	3.955419E-1	4.239680E-1
15	2.278799E-1	3.177920E-1	3.383191E-1	4.004411E-1	4.118556E-1
16	2.789686E-1	3.226197E-1	3.565811E-1	4.020676E-1	4.237045E-1

1

2

**Table 9-10 Interpolation Filter Coefficients, Cutoff=0.5 (1/2)**

$n$	$I_E(7n)$	$I_E(1 + 7n)$	$I_E(2 + 7n)$	$I_E(3 + 7n)$
0	-2.279553E-2	9.638780E-2	4.296515E-1	4.296515E-1
1	-2.165019E-2	6.437141E-2	3.936069E-1	4.594094E-1
2	-1.928710E-2	3.758768E-2	3.527558E-1	4.816282E-1
3	-1.634340E-2	1.617878E-2	3.087218E-1	4.953565E-1
4	-1.332172E-2	0.000000E+0	2.631803E-1	5.000000E-1
5	-1.057099E-2	-1.134067E-2	2.177682E-1	4.953565E-1
6	-8.282481E-3	-1.842952E-2	1.739981E-1	4.816282E-1
7	-6.500361E-3	-2.198557E-2	1.331849E-1	4.594094E-1

3

4

**Table 9-11 Interpolation Filter Coefficients, Cutoff=0.5 (2/2)**

$n$	$I_E(4 + 7n)$	$I_E(5 + 7n)$	$I_E(6 + 7n)$
0	9.638780E-2	-2.279553E-2	-5.144665E-3
1	1.331849E-1	-2.198557E-2	-6.500361E-3
2	1.739981E-1	-1.842952E-2	-8.282481E-3
3	2.177682E-1	-1.134067E-2	-1.057099E-2
4	2.631803E-1	0.000000E+0	-1.332172E-2
5	3.087218E-1	1.617878E-2	-1.634340E-2
6	3.527558E-1	3.758768E-2	-1.928710E-2
7	3.936069E-1	6.437141E-2	-2.165019E-2

5

6

**Table 9-12 Interpolation Filter Coefficients, Cutoff=0.9 (1/3)**

$n$	$I_E(17n)$	$I_E(1 + 17n)$	$I_E(2 + 17n)$	$I_E(3 + 17n)$	$I_E(4 + 17n)$
0	3.333057E-3	-4.447694E-3	3.032594E-3	5.505681E-3	-2.749339E-2
1	1.814939E-3	-1.051010E-3	-3.490370E-3	1.602235E-2	-4.161043E-2
2	3.143855E-4	1.903512E-3	-8.614938E-3	2.320955E-2	-4.897606E-2
3	-1.011791E-3	4.128520E-3	-1.191523E-2	2.662804E-2	-4.954024E-2
4	-2.054155E-3	5.477784E-3	-1.325900E-2	2.636338E-2	-4.408088E-2
5	-2.749624E-3	5.939437E-3	-1.278129E-2	2.294780E-2	-3.401131E-2
6	-3.074976E-3	5.612335E-3	-1.082686E-2	1.723493E-2	-2.113197E-2
7	-3.038022E-3	4.671966E-3	-7.873206E-3	1.024916E-2	-7.363276E-3

7

8

**Table 9-13 Interpolation Filter Coefficients, Cutoff=0.9 (2/3)**

$n$	$I_E(5 + 17n)$	$I_E(6 + 17n)$	$I_E(7 + 17n)$	$I_E(8 + 17n)$	$I_E(9 + 17n)$	$I_E(10 + 17n)$
0	7.357492E-2	-1.760500E-1	6.238571E-1	6.238571E-1	-1.760500E-1	7.357492E-2
1	8.809371E-2	-1.788657E-1	4.934066E-1	7.373307E-1	-1.480059E-1	4.678921E-2
2	9.025505E-2	-1.604327E-1	3.555172E-1	8.252803E-1	-9.275004E-2	9.433596E-3

3	8.139432E-2	-1.261773E-1	2.198452E-1	8.809472E-1	-1.067283E-2	-3.518170E-2
4	6.395375E-2	-8.231784E-2	9.530775E-2	9.000000E-1	9.530775E-2	-8.231784E-2
5	4.107321E-2	-3.518170E-2	-1.067283E-2	8.809472E-1	2.198452E-1	-1.261773E-1
6	1.614589E-2	9.433596E-3	-9.275004E-2	8.252803E-1	3.555172E-1	-1.604327E-1
7	-7.606618E-3	4.678921E-2	-1.480059E-1	7.373307E-1	4.934066E-1	-1.788657E-1

1

2

**Table 9-14 Interpolation Filter Coefficients, Cutoff=0.9 (3/3)**

$n$	$I_E(11 + 17n)$	$I_E(12 + 17n)$	$I_E(13 + 17n)$	$I_E(14 + 17n)$	$I_E(15 + 17n)$	$I_E(16 + 17n)$
0	-2.749339E-2	5.505681E-3	3.032594E-3	-4.447694E-3	3.333057E-3	-2.669328E-3
1	-7.606618E-3	-7.363276E-3	1.024916E-2	-7.873206E-3	4.671966E-3	-3.038022E-3
2	1.614589E-2	-2.113197E-2	1.723493E-2	-1.082686E-2	5.612335E-3	-3.074976E-3
3	4.107321E-2	-3.401131E-2	2.294780E-2	-1.278129E-2	5.939437E-3	-2.749624E-3
4	6.395375E-2	-4.408088E-2	2.636338E-2	-1.325900E-2	5.477784E-3	-2.054155E-3
5	8.139432E-2	-4.954024E-2	2.662804E-2	-1.191523E-2	4.128520E-3	-1.011791E-3
6	9.025505E-2	-4.897606E-2	2.320955E-2	-8.614938E-3	1.903512E-3	3.143855E-4
7	8.809371E-2	-4.161043E-2	1.602235E-2	-3.490370E-3	-1.051010E-3	1.814939E-3

3

4

**Table 9-15 Fixed Codebook Gain Quantization, Rate 1**

$k$	$g_{ccb}(k)$	$k$	$g_{ccb}(k)$
0	1.2840254E+0	16	7.0105412E+1
1	1.6487213E+0	17	9.0017131E+1
2	2.1170000E+0	18	1.1558429E+2
3	2.7182818E+0	19	1.4841316E+2
4	3.4903430E+0	20	1.9056627E+2
5	4.4816891E+0	21	2.4469193E+2
6	5.7546027E+0	22	3.1419066E+2
7	7.3890561E+0	23	4.0342879E+2
8	9.4877358E+0	24	5.1801283E+2
9	1.2182494E+1	25	6.6514163E+2
10	1.5642632E+1	26	8.5405876E+2
11	2.0085537E+1	27	1.0966332E+3
12	2.5790340E+1	28	1.4081049E+3
13	3.3115452E+1	29	1.8080424E+3
14	4.2521082E+1	30	2.3215724E+3
15	5.4598150E+1	31	2.9809580E+3

5

6

**Table 9-16 Fixed Codebook Gain Quantization, Rate 1/2**

$k$	$G_{ccb}(k)$	$k$	$G_{ccb}(k)$
0	1.6487213E+0	8	9.0017131E+1
1	2.7182818E+0	9	1.4841316E+2
2	4.4816891E+0	10	2.4469193E+2
3	7.3890561E+0	11	4.0342879E+2
4	1.2182494E+1	12	6.6514163E+2
5	2.0085537E+1	13	1.0966332E+3
6	3.3115452E+1	14	1.8080424E+3

7	5.4598150E+1	15	2.9809580E+3
---	--------------	----	--------------

1  
2

**Table 9-17 Residual Shift Interpolation Filter Coefficients**

$j$	$I_f(-1, j)$	$I_f(0, j)$	$I_f(1, j)$
0	3.750000E-01	7.500000E-01	-1.250000E-01
1	2.578125E-01	8.593750E-01	-1.171875E-01
2	1.562500E-01	9.375000E-01	-9.375000E-02
3	7.031250E-02	9.843750E-01	-5.468750E-02
4	0.000000E+00	1.000000E+00	0.000000E+00
5	-5.468750E-02	9.843750E-01	7.031250E-02
6	-9.375000E-02	9.375000E-01	1.562500E-01
7	-1.171875E-01	8.593750E-01	2.578125E-01

3  
4

**Table 9-18 Rate 1/8 Frame Energy Quantization**

$k$	$q_{log}(0, k)$	$q_{log}(1, k)$	$q_{log}(2, k)$	$k$	$q_{log}(0, k)$	$q_{log}(1, k)$	$q_{log}(2, k)$
0	-2.464E-02	-4.005E-03	-1.107E-01	128	-4.208E-02	-1.491E-01	-7.639E-02
1	8.734E-01	1.004E+00	9.930E-01	129	1.046E+00	9.598E-01	9.176E-01
2	4.222E-01	3.894E-01	5.020E-01	130	4.478E-01	4.605E-01	5.111E-01
3	1.450E+00	1.328E+00	1.278E+00	131	1.521E+00	1.292E+00	1.342E+00
4	1.957E-01	2.169E-01	2.735E-01	132	2.220E-01	2.549E-01	2.510E-01
5	1.142E+00	1.240E+00	1.157E+00	133	1.186E+00	1.254E+00	1.171E+00
6	7.881E-01	6.778E-01	4.185E-01	134	8.999E-01	4.960E-01	4.943E-01
7	1.504E+00	1.468E+00	1.534E+00	135	1.423E+00	1.484E+00	1.620E+00
8	3.173E-01	2.693E-01	-9.526E-02	136	2.796E-01	2.778E-01	-2.820E-01
9	1.141E+00	1.154E+00	1.044E+00	137	1.170E+00	1.181E+00	1.076E+00
10	5.147E-01	5.784E-01	8.802E-01	138	4.068E-01	8.541E-01	9.352E-01
11	1.502E+00	1.407E+00	1.409E+00	139	1.584E+00	1.416E+00	1.387E+00
12	3.163E-01	3.592E-01	2.830E-01	140	3.325E-01	3.655E-01	3.340E-01
13	1.217E+00	1.213E+00	1.216E+00	141	1.224E+00	1.257E+00	1.245E+00
14	1.023E+00	1.139E+00	-9.526E-02	142	1.061E+00	1.138E+00	-9.526E-02
15	1.619E+00	1.655E+00	1.642E+00	143	1.681E+00	1.704E+00	1.673E+00
16	1.437E-01	1.505E-01	6.838E-02	144	1.932E-01	1.489E-01	1.258E-01
17	9.794E-01	1.021E+00	1.117E+00	145	1.023E+00	1.088E+00	1.145E+00
18	4.701E-01	6.426E-01	5.519E-01	146	5.190E-01	6.873E-01	5.172E-01
19	1.366E+00	1.397E+00	1.406E+00	147	1.380E+00	1.405E+00	1.474E+00
20	2.918E-01	3.022E-01	2.420E-01	148	3.393E-01	3.100E-01	2.231E-01
21	1.309E+00	1.241E+00	1.220E+00	149	1.354E+00	1.249E+00	1.270E+00
22	7.989E-01	7.654E-01	7.391E-01	150	7.363E-01	8.508E-01	8.247E-01
23	1.612E+00	1.502E+00	1.447E+00	151	1.612E+00	1.537E+00	1.509E+00
24	2.594E-01	1.948E-01	2.555E-01	152	2.952E-01	2.053E-01	2.590E-01
25	1.091E+00	1.150E+00	1.272E+00	153	1.138E+00	1.219E+00	1.262E+00
26	3.423E-01	4.150E-01	1.294E+00	154	1.345E+00	1.289E+00	1.338E+00
27	1.729E+00	1.377E+00	1.065E+00	155	1.437E+00	1.360E+00	1.442E+00
28	4.103E-01	3.287E-01	3.228E-01	156	4.826E-01	3.298E-01	3.842E-01
29	1.144E+00	1.281E+00	1.416E+00	157	1.219E+00	1.311E+00	1.413E+00
30	1.047E+00	1.117E+00	6.188E-01	158	1.212E+00	1.186E+00	6.357E-01

31	1.914E+00	1.777E+00	1.516E+00	159	1.873E+00	1.939E+00	1.674E+00
32	-2.117E-02	2.159E-01	2.351E-01	160	1.260E+00	1.306E+00	1.368E+00
33	1.093E+00	1.088E+00	1.026E+00	161	1.146E+00	1.077E+00	1.025E+00
34	5.567E-01	5.092E-01	4.654E-01	162	6.029E-01	5.039E-01	5.781E-01
35	1.510E+00	1.449E+00	1.201E+00	163	1.514E+00	1.420E+00	1.324E+00
36	2.362E-01	3.426E-01	2.549E-01	164	2.652E-01	3.192E-01	3.042E-01
37	1.340E+00	1.225E+00	1.117E+00	165	1.368E+00	1.198E+00	1.200E+00
38	1.203E+00	3.819E-01	2.269E-01	166	1.234E+00	4.910E-01	3.464E-02
39	1.373E+00	1.404E+00	1.830E+00	167	1.347E+00	1.560E+00	1.861E+00
40	2.570E-01	2.668E-01	1.636E-01	168	2.766E-01	2.887E-01	2.029E-01
41	1.219E+00	1.098E+00	1.122E+00	169	1.257E+00	1.105E+00	1.145E+00
42	6.985E-01	8.456E-01	1.069E+00	170	1.351E+00	1.353E+00	1.406E+00
43	1.550E+00	1.501E+00	1.388E+00	171	1.506E+00	1.580E+00	1.362E+00
44	2.870E-01	3.060E-01	3.599E-01	172	2.794E-01	3.868E-01	4.277E-01
45	1.178E+00	1.345E+00	1.302E+00	173	1.234E+00	1.334E+00	1.336E+00
46	1.270E+00	1.215E+00	1.812E-01	174	1.280E+00	1.252E+00	1.805E-01
47	1.725E+00	1.777E+00	1.693E+00	175	1.387E+00	1.396E+00	1.434E+00
48	2.074E-01	2.104E-01	1.539E-01	176	2.902E-01	1.170E-01	1.698E-01
49	1.105E+00	1.034E+00	1.104E+00	177	1.134E+00	1.077E+00	1.117E+00
50	6.683E-01	6.646E-01	6.639E-01	178	6.986E-01	7.177E-01	7.366E-01
51	1.403E+00	1.462E+00	1.435E+00	179	1.370E+00	1.491E+00	1.495E+00
52	3.389E-01	3.754E-01	2.150E-01	180	4.031E-01	5.144E-01	1.751E-01
53	1.288E+00	1.325E+00	1.257E+00	181	1.333E+00	1.377E+00	1.257E+00
54	8.933E-01	8.253E-01	8.133E-01	182	9.212E-01	8.934E-01	8.897E-01
55	1.555E+00	1.579E+00	1.565E+00	183	1.589E+00	1.614E+00	1.523E+00
56	3.264E-01	2.434E-01	2.852E-01	184	3.152E-01	2.164E-01	3.230E-01
57	1.242E+00	1.180E+00	1.202E+00	185	1.300E+00	1.145E+00	1.212E+00
58	1.314E-01	1.698E-01	1.646E+00	186	1.269E+00	1.245E+00	1.497E+00
59	1.797E+00	1.597E+00	1.241E+00	187	1.763E+00	1.716E+00	1.311E+00
60	4.721E-01	5.346E-01	3.066E-01	188	4.702E-01	5.422E-01	4.306E-01
61	1.274E+00	1.401E+00	1.351E+00	189	1.342E+00	1.433E+00	1.423E+00
62	1.455E+00	1.386E+00	6.430E-01	190	1.472E+00	1.404E+00	8.371E-01
63	1.828E+00	1.867E+00	1.825E+00	191	1.936E+00	1.883E+00	1.838E+00
64	-3.265E-01	-2.956E-01	-2.462E-01	192	1.266E+00	1.295E+00	1.302E+00
65	1.035E+00	1.020E+00	1.003E+00	193	1.074E+00	1.002E+00	1.023E+00
66	3.702E-01	4.307E-01	7.072E-01	194	5.206E-01	4.045E-01	6.549E-01
67	1.424E+00	1.345E+00	1.352E+00	195	1.457E+00	1.378E+00	1.363E+00
68	2.267E-01	2.680E-01	3.037E-01	196	2.715E-01	2.629E-01	2.841E-01
69	1.235E+00	1.249E+00	1.146E+00	197	1.264E+00	1.271E+00	1.175E+00
70	9.944E-01	6.485E-01	5.248E-01	198	1.337E+00	1.305E+00	1.306E+00
71	1.539E+00	1.492E+00	1.612E+00	199	1.555E+00	1.571E+00	1.657E+00
72	3.815E-01	3.360E-01	-9.526E-02	200	3.341E-01	4.147E-01	-3.648E-01
73	1.163E+00	1.144E+00	1.117E+00	201	1.188E+00	1.185E+00	1.161E+00
74	6.734E-01	7.656E-01	1.014E+00	202	6.198E-01	7.208E-01	1.157E+00
75	1.568E+00	1.438E+00	1.455E+00	203	1.582E+00	1.465E+00	1.513E+00
76	3.409E-01	3.317E-01	3.856E-01	204	3.839E-01	3.651E-01	3.814E-01
77	1.180E+00	1.284E+00	1.284E+00	205	1.214E+00	1.256E+00	1.292E+00
78	1.244E+00	1.214E+00	-9.526E-02	206	1.361E+00	1.363E+00	1.312E+00

3GPP2 C.S0014-C ver 1.0

79	1.753E+00	1.598E+00	1.744E+00	207	1.793E+00	1.693E+00	1.669E+00
80	1.548E-01	1.388E-01	2.020E-01	208	1.889E-01	1.275E-01	2.534E-01
81	1.027E+00	1.133E+00	1.093E+00	209	1.066E+00	1.174E+00	1.133E+00
82	3.906E-01	7.505E-01	5.705E-01	210	4.999E-01	8.207E-01	5.813E-01
83	1.420E+00	1.357E+00	1.543E+00	211	1.478E+00	1.416E+00	1.497E+00
84	3.252E-01	3.136E-01	2.804E-01	212	3.814E-01	3.138E-01	2.889E-01
85	1.351E+00	1.309E+00	1.224E+00	213	1.396E+00	1.265E+00	1.233E+00
86	8.781E-01	8.095E-01	7.109E-01	214	9.458E-01	9.161E-01	5.875E-01
87	1.614E+00	1.580E+00	1.433E+00	215	1.672E+00	1.632E+00	1.553E+00
88	3.222E-01	2.298E-01	2.157E-01	216	3.505E-01	2.525E-01	2.364E-01
89	1.216E+00	1.077E+00	1.247E+00	217	1.211E+00	1.138E+00	1.235E+00
90	1.363E+00	1.280E+00	1.317E+00	218	1.391E+00	1.231E+00	1.355E+00
91	1.751E+00	1.457E+00	1.182E+00	219	1.783E+00	1.510E+00	1.199E+00
92	4.428E-01	4.082E-01	3.181E-01	220	4.227E-01	4.548E-01	3.671E-01
93	1.157E+00	1.227E+00	1.604E+00	221	1.281E+00	1.254E+00	1.661E+00
94	1.286E+00	1.268E+00	8.167E-01	222	1.338E+00	1.379E+00	9.531E-01
95	1.994E+00	2.018E+00	1.307E+00	223	2.148E+00	1.965E+00	1.584E+00
96	2.671E-02	2.594E-01	3.397E-01	224	9.324E-02	3.575E-01	3.522E-01
97	1.164E+00	1.080E+00	9.321E-01	225	1.212E+00	1.086E+00	1.044E+00
98	5.998E-01	6.076E-01	5.081E-01	226	6.128E-01	6.136E-01	6.060E-01
99	1.442E+00	1.442E+00	1.375E+00	227	1.484E+00	1.507E+00	1.396E+00
100	2.390E-01	3.554E-01	3.426E-01	228	2.820E-01	3.848E-01	3.156E-01
101	1.287E+00	1.307E+00	1.144E+00	229	1.368E+00	1.287E+00	1.128E+00
102	1.200E+00	7.495E-01	3.967E-01	230	1.369E+00	1.352E+00	1.358E+00
103	1.561E+00	1.517E+00	1.898E+00	231	1.381E+00	1.765E+00	2.113E+00
104	3.598E-01	3.463E-01	1.200E-01	232	1.314E+00	1.345E+00	1.334E+00
105	1.298E+00	1.125E+00	1.062E+00	233	1.290E+00	1.172E+00	1.119E+00
106	7.577E-01	1.013E+00	1.194E+00	234	1.304E+00	1.377E+00	1.427E+00
107	1.537E+00	1.513E+00	1.464E+00	235	1.490E+00	1.540E+00	1.536E+00
108	4.041E-01	4.038E-01	3.897E-01	236	3.994E-01	4.402E-01	4.173E-01
109	1.293E+00	1.219E+00	1.378E+00	237	1.323E+00	1.307E+00	1.392E+00
110	1.250E+00	1.391E+00	2.451E-01	238	1.400E+00	1.388E+00	1.369E+00
111	1.558E+00	1.764E+00	1.728E+00	239	1.669E+00	1.818E+00	1.834E+00
112	2.700E-01	1.894E-01	1.924E-01	240	2.742E-01	2.235E-01	1.986E-01
113	1.111E+00	1.112E+00	1.173E+00	241	1.137E+00	1.139E+00	1.201E+00
114	7.579E-01	8.342E-01	4.781E-01	242	1.324E+00	1.385E+00	1.349E+00
115	1.464E+00	1.477E+00	1.469E+00	243	1.455E+00	1.574E+00	1.454E+00
116	4.001E-01	3.104E-01	2.217E-01	244	5.019E-01	3.255E-01	2.555E-01
117	1.346E+00	1.421E+00	1.312E+00	245	1.388E+00	1.438E+00	1.300E+00
118	1.071E+00	8.967E-01	7.511E-01	246	1.394E+00	1.349E+00	1.411E+00
119	1.616E+00	1.551E+00	1.574E+00	247	1.639E+00	1.580E+00	1.681E+00
120	3.329E-01	2.785E-01	3.140E-01	248	3.920E-01	2.498E-01	3.523E-01
121	1.281E+00	1.209E+00	1.239E+00	249	1.301E+00	1.221E+00	1.285E+00
122	2.805E-01	2.687E-01	1.646E+00	250	1.318E+00	1.342E+00	1.494E+00
123	1.814E+00	1.514E+00	1.510E+00	251	1.910E+00	1.680E+00	1.470E+00
124	6.231E-01	4.200E-01	3.701E-01	252	6.082E-01	5.270E-01	4.173E-01
125	1.255E+00	1.429E+00	1.454E+00	253	1.255E+00	1.477E+00	1.503E+00
126	1.642E+00	1.581E+00	7.112E-01	254	1.807E+00	1.742E+00	6.553E-01

127	1.844E+00	1.963E+00	1.895E+00	255	2.000E+00	2.072E+00	2.051E+00
-----	-----------	-----------	-----------	-----	-----------	-----------	-----------

- 1
- 2
- 3
- 4
- 5
- 6
- 7
- 8
- 9
- 10
- 11
- 12
- 13
- 14
- 15
- 16
- 17
- 18
- 19
- 20
- 21
- 22
- 23
- 24
- 25
- 26
- 27
- 28
- 29
- 30
- 31
- 32
- 33
- 34
- 35
- 36
- 37
- 38
- 39

This page intentionally left blank