

**3GPP2 C.S0010-D**

**Version 1.0**

**September 2010**



**3RD GENERATION  
PARTNERSHIP  
PROJECT 2  
"3GPP2"**

---

## ***Recommended Minimum Performance Standards for cdma2000 Spread Spectrum Base Stations***

© 2010 3GPP2

3GPP2 and its Organizational Partners claim copyright in this document and individual Organizational Partners may copyright and issue documents or standards publications in individual Organizational Partner's name based on this document. Requests for reproduction of this document should be directed to the 3GPP2 Secretariat at [secretariat@3gpp2.org](mailto:secretariat@3gpp2.org). Requests to reproduce individual Organizational Partner's documents should be directed to that Organizational Partner. See [www.3gpp2.org](http://www.3gpp2.org) for more information.

**Revision History**

<b>Rel 0 v1.0</b>	<b>First 3GPP2 Publication – Support for cdma2000-0©</b>	<b>December 1999</b>
<b>Rev A v1.0</b>	<b>Support for cdma2000-A©</b>	<b>April 2001</b>
<b>Rev B v1.0</b>	<b>Added Band Classes</b>	<b>December 2002</b>
<b>Rev B v2.0</b>	<b>Bug fix</b>	<b>March 2004</b>
<b>Rev C v1.0</b>	<b>Support for cdma2000-B©</b>	<b>February 2005</b>
<b>Rev C v2.0</b>	<b>Bug fix</b>	<b>March 2006</b>
<b>Rev D v1.0</b>	<b>Added support for Pico and Femto Cells</b>	<b>September 2010</b>

**CONTENTS**

1	FOREWORD .....	xiv
2	NOTES .....	xiv
3	INTRODUCTION .....	1-1
4	1.1 Scope .....	1-1
5	1.2 Terms and Definitions .....	1-1
6	1.3 Test Modes .....	1-10
7	2 STANDARD EMISSIONS MEASUREMENT PROCEDURES .....	2-1
8	2.1 Radiated Emissions Measurement .....	2-1
9	2.1.1 Standard Radiation Test Site .....	2-1
10	2.1.2 Search Antenna .....	2-1
11	2.1.3 Field-Strength Measurement .....	2-2
12	2.1.4 Frequency Range of Measurements .....	2-2
13	2.1.5 Test Ranges .....	2-2
14	2.1.5.1 30-Meter Test Range .....	2-2
15	2.1.5.2 3-Meter Test Range .....	2-3
16	2.1.6 Radiated Signal Measurement Procedures .....	2-3
17	2.2 AC Power Line Conducted Emissions Measurement .....	2-4
18	2.2.1 Standard AC Power Line Conducted Emissions Test Site .....	2-4
19	2.2.2 Line Impedance Stabilization Network (LISN) Unit .....	2-4
20	2.2.3 Standard Test Site Measurements .....	2-5
21	2.2.3.1 Floor Standing Equipment .....	2-5
22	2.2.3.2 Table Top Mounted Equipment .....	2-5
23	2.2.3.3 Measurement Procedure .....	2-5
24	2.2.3.4 Frequency Range of Measurements .....	2-5
25	2.2.4 End User or Manufacturing Plant Test Sites .....	2-5
26	3 CDMA RECEIVER MINIMUM STANDARDS .....	3-1
27	3.1 Frequency Coverage Requirements .....	3-1
28	3.2 Access Probe Acquisition .....	3-1
29	3.2.2 Method of Measurement .....	3-1
30	3.2.2.1 Access Channel Probe Acquisition .....	3-1
31	3.2.2.2 Enhanced Access Channel Probe Acquisition .....	3-2

**CONTENTS**

1	3.2.3 Minimum Standard.....	3-4
2	3.3 Reverse Common Control Channel Demodulation Performance.....	3-4
3	3.3.1 Performance in Additive White Gaussian Noise .....	3-4
4	3.3.1.1 Definition .....	3-4
5	3.3.1.2 Method of Measurement .....	3-5
6	3.3.1.3 Minimum Standard .....	3-7
7	3.3.2 Performance in Multipath Fading with Closed Loop Power Control.....	3-7
8	3.3.2.1 Definition .....	3-7
9	3.3.2.2 Method of Measurement .....	3-7
10	3.3.2.3 Minimum Standard .....	3-9
11	3.4 Reverse Channel Quality Indicator Channel Demodulation Performance.....	3-10
12	3.4.1 Performance in Additive White Gaussian Noise .....	3-10
13	3.4.1.1 Definition .....	3-10
14	3.4.1.2 Method of Measurement .....	3-10
15	3.4.1.3 Minimum Standard .....	3-11
16	3.4.2 Performance in Multipath Fading with Closed Loop Power Control.....	3-11
17	3.4.2.1 Definition .....	3-11
18	3.4.2.2 Method of Measurement .....	3-11
19	3.4.2.3 Minimum Standard .....	3-13
20	3.5 Reverse Acknowledgment Channel Demodulation Performance.....	3-13
21	3.5.1 Performance in Additive White Gaussian Noise .....	3-13
22	3.5.1.1 Definition .....	3-13
23	3.5.1.2 Method of Measurement .....	3-13
24	3.5.1.3 Minimum Standard .....	3-14
25	3.5.2 Performance in Multipath Fading with Closed Loop Power Control.....	3-15
26	3.5.2.1 Definition .....	3-15
27	3.5.2.2 Method of Measurement .....	3-15
28	3.5.2.3 Minimum Standard .....	3-16
29	3.6 Reverse Traffic Channel Demodulation Performance .....	3-17
30	3.6.1 Performance in Additive White Gaussian Noise .....	3-17
31	3.6.1.1 Definition .....	3-17

**CONTENTS**

1	3.6.1.2 Method of Measurement .....	3-17
2	3.6.1.3 Minimum Standard.....	3-18
3	3.6.2 Performance in Multipath Fading without Closed Loop Power Control .....	3-19
4	3.6.2.1 Definition.....	3-19
5	3.6.2.2 Method of Measurement .....	3-19
6	3.6.2.3 Minimum Standard.....	3-20
7	3.6.3 Performance in Multipath Fading with Closed Loop Power Control .....	3-20
8	3.6.3.1 Definition.....	3-20
9	3.6.3.2 Method of Measurement .....	3-20
10	3.6.3.3 Minimum Standard.....	3-22
11	3.7 Receiver Performance .....	3-22
12	3.7.1 Receiver Sensitivity .....	3-22
13	3.7.1.1 Definition.....	3-22
14	3.7.1.2 Method of Measurement .....	3-22
15	3.7.1.3 Minimum Standard.....	3-23
16	3.7.2 Receiver Dynamic Range .....	3-23
17	3.7.2.1 Definition.....	3-23
18	3.7.2.2 Method of Measurement .....	3-23
19	3.7.2.3 Minimum Standard.....	3-24
20	3.7.3 Single Tone Desensitization.....	3-24
21	3.7.3.1 Definition.....	3-24
22	3.7.3.2 Method of Measurement .....	3-25
23	3.7.3.3 Minimum Standard.....	3-27
24	3.7.4 Intermodulation Spurious Response Attenuation .....	3-27
25	3.7.4.1 Definition.....	3-27
26	3.7.4.2 Method of Measurement .....	3-28
27	3.7.4.3 Minimum Standard.....	3-30
28	3.7.5 Adjacent Channel Selectivity .....	3-30
29	3.7.5.1 Definition.....	3-30
30	3.7.5.2 Method of Measurement .....	3-30
31	3.7.5.3 Minimum Standard.....	3-31

**CONTENTS**

1	3.7.6 Receiver Blocking.....	3-31
2	3.7.6.1 Definition .....	3-31
3	3.7.6.2 Method of Measurement .....	3-31
4	3.7.6.3 Minimum Standard .....	3-33
5	3.8 Limitations on Emissions .....	3-33
6	3.8.1 Conducted Spurious Emissions .....	3-33
7	3.8.1.1 Definition .....	3-33
8	3.8.1.2 Method of Measurement .....	3-33
9	3.8.1.3 Minimum Standard .....	3-34
10	3.8.2 Radiated Spurious Emissions .....	3-35
11	3.9 Received Signal Quality Indicator (RSQI) .....	3-35
12	3.9.1 Definition.....	3-35
13	3.9.2 Method of Measurement.....	3-35
14	3.9.3 Minimum Standard.....	3-37
15	4 CDMA TRANSMITTER MINIMUM STANDARDS .....	4-1
16	4.1 Frequency Requirements.....	4-1
17	4.1.1 Frequency Coverage .....	4-1
18	4.1.2 Frequency Tolerance .....	4-1
19	4.1.2.1 Definition .....	4-1
20	4.1.2.2 Method of Measurement .....	4-1
21	4.1.2.3 Minimum Standard .....	4-1
22	4.2 Modulation Requirements .....	4-1
23	4.2.1 Synchronization and Timing.....	4-2
24	4.2.1.1 Pilot Time Tolerance .....	4-2
25	4.2.1.1.1 Definition.....	4-2
26	4.2.1.1.2 Method of Measurement .....	4-2
27	4.2.1.1.3 Minimum Standard .....	4-2
28	4.2.1.2 Pilot Channel to Code Channel Time Tolerance.....	4-3
29	4.2.1.2.1 Definition.....	4-3
30	4.2.1.2.2 Method of Measurement .....	4-3
31	4.2.1.2.3 Minimum Standard .....	4-3

**CONTENTS**

1	4.2.1.3 Pilot Channel to Code Channel Phase Tolerance .....	4-4
2	4.2.1.3.1 Definition .....	4-4
3	4.2.1.3.2 Method of Measurement .....	4-4
4	4.2.1.3.3 Minimum Standard .....	4-4
5	4.2.2 Waveform Quality .....	4-4
6	4.2.2.1 Definition .....	4-4
7	4.2.2.2 Method of Measurement .....	4-4
8	4.2.2.3 Minimum Standard .....	4-5
9	4.2.3 Forward Power Control Subchannel .....	4-5
10	4.2.3.1 Definition .....	4-5
11	4.2.3.2 Method of Measurement .....	4-5
12	4.2.3.3 Minimum Standard .....	4-8
13	4.3 RF Output Power Requirements .....	4-8
14	4.3.1 Total Power .....	4-8
15	4.3.1.1 Definition .....	4-8
16	4.3.1.2 Method of Measurement .....	4-8
17	4.3.1.3 Minimum Standard .....	4-9
18	4.3.2 Pilot Power .....	4-9
19	4.3.2.1 Definition .....	4-9
20	4.3.2.2 Method of Measurement .....	4-9
21	4.3.2.3 Minimum Standard .....	4-9
22	4.3.3 Code Domain Power .....	4-10
23	4.3.3.1 Definition .....	4-10
24	4.3.3.2 Method of Measurement .....	4-10
25	4.3.3.3 Minimum Standard .....	4-10
26	4.3.4 Femto Cell Transmission Authorization .....	4-11
27	4.3.4.1 Definition .....	4-11
28	4.3.4.2 Method of Measurement .....	4-11
29	4.3.4.3 Minimum Standard .....	4-12
30	4.4 Limitations on Emissions .....	4-12
31	4.4.1 Conducted Spurious Emissions .....	4-12

**CONTENTS**

1	4.4.1.1 Macro Cell Base Station.....	4-12
2	4.4.1.1.1 Definition .....	4-12
3	4.4.1.1.2 Method of Measurement .....	4-12
4	4.4.1.1.3 Minimum Standard .....	4-13
5	4.4.1.2.1 Definition .....	4-18
6	4.4.1.2.2 Method of Measurement .....	4-19
7	4.4.1.2.3 Minimum Standard .....	4-21
8	4.4.2 Radiated Spurious Emissions .....	4-26
9	4.4.3 Inter-Base Station Transmitter Intermodulation.....	4-27
10	4.4.3.1 Definition .....	4-27
11	4.4.3.2 Method of Measurement.....	4-27
12	4.4.3.3 Minimum Standard .....	4-27
13	4.4.4 Occupied Bandwidth.....	4-27
14	4.4.4.1 Definition .....	4-28
15	4.4.4.2 Method of Measurement .....	4-28
16	4.4.4.3 Minimum Standard .....	4-28
17	5 CDMA GENERAL REQUIREMENTS .....	5-1
18	5.1 Temperature and Power Supply Voltage .....	5-1
19	5.1.1 Definition .....	5-1
20	5.1.2 Method of Measurement.....	5-1
21	5.1.3 Minimum Standard.....	5-1
22	5.2 High Humidity .....	5-2
23	5.2.1 Definition .....	5-2
24	5.2.2 Method of Measurement.....	5-2
25	5.2.3 Minimum Standard.....	5-2
26	5.3 AC Power Line Conducted Emissions .....	5-2
27	5.3.1 Definition .....	5-2
28	5.3.2 Method of Measurement.....	5-3
29	5.3.3 Minimum Standard.....	5-3
30	6 CDMA STANDARD TEST CONDITIONS .....	6-1
31	6.1 Standard Equipment.....	6-1

**CONTENTS**

1	6.1.1 Basic Equipment .....	6-1
2	6.1.2 Associated Equipment .....	6-1
3	6.2 Standard Environmental Test Conditions .....	6-1
4	6.3 Standard Conditions for the Primary Power Supply .....	6-1
5	6.3.1 General .....	6-1
6	6.3.2 Standard DC Test Voltage from Accumulator Batteries .....	6-1
7	6.3.3 Standard AC Voltage and Frequency .....	6-2
8	6.4 Standard Test Equipment .....	6-2
9	6.4.1 Channel Simulator .....	6-2
10	6.4.2 Waveform Quality Measurement Equipment .....	6-5
11	6.4.2.1 Rho Meter .....	6-5
12	6.4.2.2 Code Domain Measurement Equipment .....	6-7
13	6.4.3 Mobile Station Simulator .....	6-9
14	6.4.4 AWGN Generator .....	6-9
15	6.4.5 CW Generator .....	6-10
16	6.4.6 Spectrum Analyzer .....	6-10
17	6.4.7 Average Power Meter .....	6-11
18	6.4.8 RF Output Load .....	6-11
19	6.5 Test Setups .....	6-12
20	6.5.1 Functional System Setups .....	6-12
21	6.5.3 General Comments .....	6-19
22	6.6 Standard Duty Cycle .....	6-20
23	6.7 Frame Error Rate Measurement .....	6-20
24	6.8 Confidence Limits .....	6-21
25	ANNEX A PERFORMANCE REQUIREMENTS .....	A-1
26	A.1 Access Channel and Enhanced Access Channel Performance .....	A-1
27	A.2 Reverse Common Control Channel Performance .....	A-3
28	A.2.1 AWGN Performance Requirements .....	A-3
29	A.2.2 Fading Channel Performance Requirements .....	A-3
30	A.3 Reverse Channel Quality Indicator Channel Performance .....	A-7
31	A.3.1 AWGN Performance Requirements .....	A-7

**CONTENTS**

1 A.3.2 Fading Channel Performance Requirements with Closed Loop Power Control .....A-8  
2 A.4 Reverse Acknowledgment Channel Performance .....A-9  
3 A.4.1 AWGN Performance Requirements .....A-9  
4 A.4.2 Fading Channel Performance Requirements with Closed Loop Power Control .....A-10  
5 A.5 Reverse Traffic Channel Performance .....A-11  
6 A.5.1 AWGN Performance Requirements .....A-11  
7 A.5.2 Fading Channel Performance Requirements without Closed Loop Power .....A-14  
8 A.5.3 Fading Channel Performance Requirements with Closed Loop Power Control .....A-19  
9

**FIGURES**

1	Figure 4.2.3.2-1. Power Up Command Measurement Interval.....	7
2	Figure 4.2.3.2-2. Path Loss Increase and Decrease Responses and the Test Points for the	
3	Alternative Test Procedure .....	8
4	Figure 6.4.1-1. Autocorrelation Coefficient of the Phase .....	3
5	Figure 6.5.1-1. Functional Setup for Base Station Additive White Gaussian Noise	
6	Demodulation Tests and Sensitivity Tests .....	13
7	Figure 6.5.1-2. Functional Setup for Base Station Multipath Fading Tests .....	13
8	Figure 6.5.1-3. Functional Setup for Base Station Desensitization Tests .....	14
9	Figure 6.5.1-4. Functional Setup for Base Station Intermodulation Spurious Response	
10	Tests .....	14
11	Figure 6.5.1-5. Functional Setup for Waveform Quality Test .....	15
12	Figure 6.5.1-6. Functional Setup for Code Domain Power Test for Non-Transmit Diversity	
13	Configuration.....	15
14	Figure 6.5.1-7. Functional Setup for Code Domain Power Test for Transmit Diversity	
15	Configuration.....	16
16	Figure 6.5.1-8. Functional Setup for Base Station ACS Tests .....	16
17	Figure 6.5.1-9. Functional Setup for Inter-Base Station Intermodulation Test.....	17
18	Figure 6.8-1. Rate Ratio Bound as a Function of Number of Errors (K) for 90 and 95%	
19	Confidence.....	26
20		

**TABLES**

1	Table 1.3-1. Test Configuration Combinations .....	11
2	Table 3.7.1.2-1: Base Station Sensitivity .....	23
3	Table 3.7.2.2-1: Base Station Dynamic Range.....	24
4	Table 3.9.3-1. Bounds on RSQI Reports.....	37
5	Table 4.4.1.3-1. Band Class 0, 2, 5, 7, 9, and 10 Transmitter Spurious Emission Limits ..	22
6	Table 4.4.1.3-2. Band Class 1, 4, 6, 8, 14, and 15 Transmitter Spurious Emission Limits	23
7	Table 4.4.1.3-3. Band Class 11 and 12 Transmitter Spurious Emission Limits .....	24
8	Table 4.4.1.3-4. Band Class 3 Transmitter Spurious Emission Limits.....	25
9	Table 4.4.1.3-5. Additional Band Class 6 Transmitter Spurious Emission Limits .....	26
10	Table 4.4.1.3-6. Additional Band Class 10 Transmitter Spurious Emission Limits for North	
11	American Operation.....	26
12	Table 5.1.3-1. Environmental Test Limits.....	2
13	Table 6.4.1-1. Standard Channel Simulator Configurations .....	4
14	Table 6.4.2.1-1. Accuracy of Waveform Quality Measurement Equipment.....	7
15	Table 6.4.2.2-1. Accuracy of Code Domain Measurement Equipment.....	8
16	Table 6.5.2-1. Radio Configuration 1 through 9 Base Station Test Model, Nominal for Main	
17	Path.....	18
18	Table 6.5.2-2. Radio Configuration 1 through 9 Base Station Test Model, Nominal for	
19	Transmit Diversity Path.....	19
20	Table 6.5.2-3. Radio Configuration 10 Base Station Test Model) .....	19
21	Table 6.8-1. Trial Count (N) Thresholds for 95% Confidence.....	24
22	Table 6.8-2. Trial Count (N) Thresholds for 90% Confidence.....	25
23	Table A.1-1. Maximum Access Probe Failure Rates .....	1
24	Table A.1-2. Maximum Spreading Rate 1 Enhanced Access Probe Failure Rates .....	2
25	Table A.2.1-1. Maximum FER for Reverse Common Control Channel Demodulation	
26	Performance Tests in AWGN .....	3
27	Table A.2.2-1. Maximum FER for Spreading Rate 1 Reverse Common Control Channel	
28	Demodulation Performance Tests in Multipath Fading (Part 1 of 4).....	4
29	Table A.2.2-1. Maximum FER for Spreading Rate 1 Reverse Common Control Channel	
30	Demodulation Performance Tests in Multipath Fading (Part 2 of 4).....	5
31	Table A.2.2-1. Maximum FER for Spreading Rate 1 Reverse Common Control Channel	
32	Demodulation Performance Tests in Multipath Fading (Part 3 of 4).....	6

**TABLES**

1	Table A.2.2-1. Maximum FER for Spreading Rate 1 Reverse Common Control Channel	
2	Demodulation Performance Tests in Multipath Fading (Part 4 of 4) .....	7
3	Table A.3.1-1. Maximum FER for Reverse Channel Quality Indicator Channel Performance	
4	Tests in AWGN .....	8
5	Table A.3.2-1. Maximum FER for Reverse Channel Quality Indicator Channel Performance	
6	Tests in Multipath Fading .....	9
7	Table A.4.1-1. Limits on False Alarm Rate (FAR) and Missed Detection Rate (MDR) for	
8	Reverse Acknowledgment Channel Performance Test in AWGN .....	10
9	Table A.4.2-1. Limits on False Alarm Rate (FAR) and Missed Detection Rate (MDR) for	
10	Reverse Acknowledgment Channel Performance Test 1 in Multipath Fading .....	10
11	Table A.5.1-1. Maximum FER for Radio Configuration 1 Reverse Fundamental Channel or	
12	Reverse Supplemental Code Channel Performance Tests in AWGN .....	11
13	Table A.5.1-2. Maximum FER for Radio Configuration 2 Reverse Fundamental Channel or	
14	Reverse Supplemental Code Channel Performance Tests in AWGN .....	11
15	Table A.5.1-3. Maximum FER for Radio Configuration 3 Reverse Fundamental Channel or	
16	Reverse Dedicated Control Channel Performance Tests in AWGN.....	12
17	Table A.5.1-4. Maximum FER for Radio Configuration 3 Reverse Supplemental Channel	
18	Performance Tests in AWGN with Convolutional Coding.....	12
19	Table A.5.1-5. Maximum FER for Radio Configuration 3 Reverse Supplemental Channel	
20	Performance Tests in AWGN with Turbo Coding.....	13
21	Table A.5.1-6. Maximum FER for Radio Configuration 4 Reverse Fundamental Channel or	
22	Reverse Dedicated Control Channel Performance Tests in AWGN.....	13
23	Table A.5.1-7. Maximum FER for Radio Configuration 4 Reverse Supplemental Channel	
24	Performance Tests in AWGN with Convolutional Coding.....	13
25	Table A.5.1-8. Maximum FER for Radio Configuration 4 Reverse Supplemental Channel	
26	Performance Tests in AWGN with Turbo Coding.....	14
27	Table A.5.2-1. $E_b/N_0$ Limits for Reverse Traffic Channel Performance Tests in Multipath	
28	Fading without Closed Loop Power Control .....	15
29	Table A.5.2-2. Maximum FER for Radio Configuration 1 Reverse Traffic Channel	
30	Performance Tests in Multipath Fading (Part 1 of 2).....	16
31	Table A.5.2-2. Maximum FER for Radio Configuration 1 Reverse Traffic Channel	
32	Performance Tests in Multipath Fading (Part 2 of 2).....	17
33	Table A.5.2-3. Maximum FER for Radio Configuration 2 Reverse Traffic Channel	
34	Performance Tests in Multipath Fading (Part 1 of 2).....	18
35	Table A.5.2-3. Maximum FER for Radio Configuration 2 Reverse Traffic Channel	
36	Performance Tests in Multipath Fading (Part 2 of 2).....	19

**TABLES**

1	Table A.5.3-1. Maximum FER for Radio Configuration 1 Fundamental Channel	
2	Demodulation Performance Tests in Multipath Fading.....	20
3	Table A.5.3-2. Maximum FER for Radio Configuration 2 Fundamental Channel	
4	Demodulation Performance Tests in Multipath Fading.....	21
5	Table A.5.3-3. Maximum FER for Radio Configuration 3 Fundamental Channel or	
6	Dedicated Control Channel Demodulation Performance Tests in Multipath Fading (Part	
7	1 of 4).....	22
8	Table A.5.3-3. Maximum FER for Radio Configuration 3 Fundamental Channel or	
9	Dedicated Control Channel Demodulation Performance Tests in Multipath Fading (Part	
10	2 of 4).....	23
11	Table A.5.3-3. Maximum FER for Radio Configuration 3 Fundamental Channel or	
12	Dedicated Control Channel Demodulation Performance Tests in Multipath Fading (Part	
13	3 of 4).....	24
14	Table A.5.3-3. Maximum FER for Radio Configuration 3 Fundamental Channel or	
15	Dedicated Control Channel Demodulation Performance Tests in Multipath Fading (Part	
16	4 of 4).....	25
17	Table A.5.3-4. Maximum FER for Radio Configuration 3 Dedicated Control Channel	
18	Demodulation Performance Tests in Multipath Fading at 10% Frame Activity.....	26
19	Table A.5.3-5. Maximum FER for Radio Configuration 3 Supplemental Channel	
20	Demodulation Performance Tests in Multipath Fading with Convolutional Coding.....	27
21	Table A.5.3-6. Maximum FER for Radio Configuration 3 Supplemental Channel	
22	Demodulation Performance Tests in Multipath Fading with Turbo Coding.....	28
23	Table A.5.3-7. Maximum FER for Radio Configuration 4 Fundamental Channel or	
24	Dedicated Control Channel Demodulation Performance Tests in Multipath Fading (Part	
25	1 of 4).....	29
26	Table A.5.3-7. Maximum FER for Radio Configuration 4 Fundamental Channel or	
27	Dedicated Control Channel Demodulation Performance Tests in Multipath Fading (Part	
28	2 of 4).....	30
29	Table A.5.3-7. Maximum FER for Radio Configuration 4 Fundamental Channel or	
30	Dedicated Control Channel Demodulation Performance Tests in Multipath Fading (Part	
31	3 of 4).....	31
32	Table A.5.3-7. Maximum FER for Radio Configuration 4 Fundamental Channel or	
33	Dedicated Control Channel Demodulation Performance Tests in Multipath Fading (Part	
34	4 of 4).....	32
35	Table A.5.3-8. Maximum FER for Radio Configuration 4 Dedicated Control Channel	
36	Demodulation Performance Tests in Multipath Fading at 10% Frame Activity.....	33
37	Table A.5.3-9. Maximum FER for Radio Configuration 4 Supplemental Channel	
38	Demodulation Performance Tests in Multipath Fading with Convolutional Coding.....	34

**TABLES**

1 Table A.5.3-10. Maximum FER for Radio Configuration 4 Supplemental Channel  
2 Demodulation Performance Tests in Multipath Fading with Turbo Coding ..... 35  
3  
4

**FOREWORD**

The foreword is not part of this specification.

Minimum Performance Specifications for network devices and mobile devices form a vital part of any cellular system design. Based on the technologies defined in the air interface, the minimum and maximum power requirements set limits on the allowable path loss that may be used in the system design of an operating system. Emission limits are designed to prevent unwanted interference. Proper signal quality is essential for good link quality. Mobility models that are representative of realistic cases have been used.

This specification sets minimum performance standards for base stations.

**NOTES**

1. “Base station” refers to the functions performed on the land side, which are typically distributed among a cell, a sector of a cell, and a mobile switching center.
2. This standard uses the following verbal forms: “Shall” and “shall not” identify requirements to be followed strictly to conform to the standard and from which no deviation is permitted. “Should” and “should not” indicate that one of several possibilities is recommended as particularly suitable, without mentioning or excluding others; that a certain course of action is preferred but not necessarily required; or that (in the negative form) a certain possibility or course of action is discouraged but not prohibited. “May” and “need not” indicate a course of action permissible within the limits of the standard. “Can” and “cannot” are used for statements of possibility and capability, whether material, physical, or causal.
3. Unless indicated otherwise, this document presents numbers in decimal form. Binary numbers are distinguished in the text by the use of single quotation marks.
4. Those wishing to deploy systems compliant with this standard should also be compliant with local radio regulations. For example, operation within the United States of America shall comply with Title 47, Parts 15, 22, 24, and 27 of the Code of Federal Regulations.
5. The following operators define mathematical operations:
  - × indicates multiplication.
  - / indicates division.
  - + indicates addition.
  - indicates subtraction.
  - \* indicates complex conjugation.

$\lfloor x \rfloor$  indicates the largest integer less than or equal to  $x$ :  $\lfloor 1.1 \rfloor = 1$ ,  $\lfloor 1.0 \rfloor = 1$ .

$|x|$  indicates the absolute value of  $x$ :  $|-17| = 17$ ,  $|17| = 17$ .
6. All  $E_b/N_0$  requirements in this document are based on simulated data.

- 1 7. This Standard supports testing of base stations compliant with [3] and subsequent  
2 revisions.
- 3 8. This Standard supports base station deployments by different manufacturers  
4 within the same operator block and band, including alternating channel  
5 implementations where vendor 1 is deployed on odd carriers and vendor 2 is  
6 deployed on even carriers to minimize combining losses. This Standard also  
7 supports the mixing of technologies within the same operator's block and band.  
8 This is accomplished by referencing single tone desense, intermodulation spurious  
9 response attenuation, and spurious emissions to each carrier independently.
- 10 9. The specification applies only to Band Classes 0 (Band Subclasses 0 and 1), 1, 2,  
11 (Band Subclasses 0, 1, and 2), 3, 4, 5 (Band Subclasses 0 through 7), 6, 7, 8, 9, 10  
12 (Band Subclasses 0 through 4), 11 (Band Subclasses 0 through 5), 12 (Band  
13 Subclasses 0 and 1), 14, and 15 as defined in [17]. Operation with other band  
14 classes and band subclasses may not be supported by this specification.
- 15 10. A vendor may declare the MPS requirements for a base station type that the  
16 equipment under test shall meet.
- 17 11. This specification does not address the receiver demodulation performance of  
18 single-receive-antenna femto cells. Conformance with this specification should not  
19 be used to determine the suitability of single-receive-antenna femto cells in system  
20 deployments. Additional tests will be provided in future revisions to determine the  
21 required receiver demodulation performance for single-antenna femto cells to  
22 address issues such as proper handoff to macro cells.

23

24

**NORMATIVE REFERENCES**

The following standards contain provisions which, through reference in this text, constitute provisions of this Standard. At the time of publication, the editions indicated were valid. All standards are subject to revision, and parties to agreements based on this Standard are encouraged to investigate the possibility of applying the most recent editions of the standards indicated below. ANSI and TIA maintain registers of currently valid national standards published by them.

*General References*

1.	ANSI C63.4-2003, American National Standard for Methods of Measurement of Radio-Noise Emissions from Low-Voltage Electrical and Electronic Equipment in the Range of 9 kHz to 40 GHz, 2003.
2.	CFR Title 47, Code of Federal Regulations, October 2003.

*3GPP2 Specifications and SDO Standards*

3.	C.S0002-D	Physical Layer Standard for cdma2000 Spread Spectrum Systems, 2004.
4.	C.S0011-C	Recommended Minimum Performance Standards for cdma2000 Spread Spectrum Mobile Stations, 2004.
5.	C.S0013-A	Loopback Service Options (LSO) for cdma2000 Spread Spectrum Systems, 2001.
6.	C.S0026-A	Test Data Service Option (TDSO) for cdma2000 Spread Spectrum Systems, 2004.
7.	X.S0059-100-0	Femto Network Specification

## 1 INTRODUCTION

### 1.1 Scope

This Standard details definitions, methods of measurement, and minimum performance requirements for Code Division Multiple Access (CDMA) base stations. This Standard shares the purpose of [3] (and subsequent revisions thereof) by ensuring that a mobile station can obtain service in any system that meets the compatibility requirements of [3].

Compatibility, as used in connection with this Standard and [3], is understood to mean that any mobile station is able to place and receive calls in any system. Conversely, all systems are able to place and receive calls with any mobile station.

Test methods are recommended in this document; however, methods other than those recommended may suffice for the same purpose.

### 1.2 Terms and Definitions

**Access Attempt.** A sequence of one or more access probe sequences on the Access Channel or Enhanced Access Channel containing the same message. See also Access Probe, Access Probe Sequence, and Enhanced Access Probe.

**Access Channel.** A Reverse CDMA Channel used by mobile stations for communicating to the base station. The Access Channel is used for short signaling message exchanges, such as call originations, responses to pages, and registrations. The Access Channel is a slotted random access channel.

**Access Channel Preamble.** The preamble of an access probe consisting of a sequence of all-zero frames that is sent at the 4800 bps rate.

**Access Probe.** One Access Channel transmission consisting of a preamble and a message. The transmission is an integer number of frames in length, and transmits one Access Channel message. See also Access Probe Sequence and Access Attempt.

**Access Probe Sequence.** A sequence of one or more access probes on the Access Channel or Enhanced Access Channel. The same Access Channel or Enhanced Access Channel message is transmitted in every access probe of an access attempt. See also Access Probe, Enhanced Access Probe, and Access Attempt.

**ACLR.** Adjacent Channel Leakage Ratio.

**Active Frame.** A frame that contains data and therefore is enabled in terms of traffic power.

**Adjacent Channel Leakage Ratio.** The ratio of the on-channel transmit power to the power measured in one of the adjacent channels.

**AWGN.** Additive White Gaussian Noise.

**Band Class.** A set of frequency channels and a numbering scheme for these channels.

**Band Group 1900.** A collection of band classes that use the 1900 MHz simulation results for fading conditions. This group consists of Band Class 1 (1900 MHz Band), Band Class 4

1 (Korean PCS Band), Band Class 6 (2 GHz Band), Band Class 8 (1800 MHz Band), Band  
2 Class 14 (US 1900 MHz Band), and Band Class 15 (AWS Band).

3 **Band Group 450.** A collection of band classes that use the 450 MHz simulation results for  
4 fading conditions. This group consists of Band Class 5 (450 MHz Band) and Band Class 11  
5 (400 MHz European PAMR Band).

6 **Band Group 800.** A collection of band classes that use the 800 MHz simulation results for  
7 fading conditions. This group consists of Band Class 0 (800 MHz Band), Band Class 2  
8 (TACS Band), Band Class 3 (JTACS Band), Band Class 7 (700 MHz Band), Band Class 9  
9 (900 MHz Band), Band Class 10 (Secondary 800 MHz Band), and 12 (800 MHz European  
10 PAMR Band).

11 **Base Station.** A fixed station used for communicating with mobile stations. Depending  
12 upon the context, the term base station may refer to a cell, a sector within a cell, an MSC,  
13 or other part of the wireless system. In the context of transmitter testing, a base station  
14 applies to operation with a single carrier and single sector active only. See also MSC.

15 **Basic Access Mode.** A mode used on the Enhanced Access Channel where a mobile station  
16 transmits an Enhanced Access Channel preamble and Enhanced Access data in a method  
17 similar to that used on the Access Channel.

18 **bps.** Bits per second.

19 **CDMA.** See Code Division Multiple Access.

20 **CDMA Channel.** The set of channels transmitted from the base station and the mobile  
21 stations on a given frequency.

22 **CDMA Channel Number.** An 11-bit number corresponding to the center of the CDMA  
23 frequency assignment.

24 **CDMA Frequency Assignment.** A 1.23 MHz segment of spectrum. For Band Class 0, the  
25 channel is centered on one of the 30 kHz channels. For Band Classes 1, 4, 6, 7, 8, 9, and  
26 10 the channel is centered on one of the 50 kHz channels. For Band Classes 2, 3, 11, and  
27 12, the channel is centered on one of the 25 kHz channels. For Band Class 5, the channel  
28 is centered on one of the 20 or 25 kHz channels.

29 **CDMA Preferred Set.** The set of CDMA channel numbers in a CDMA system corresponding  
30 to frequency assignments that a mobile station will normally search to acquire a CDMA  
31 Pilot Channel.

32 **Code Channel.** A subchannel of a Forward CDMA Channel or Reverse CDMA Channel.  
33 Each subchannel uses an orthogonal Walsh function or quasi-orthogonal function.

34 **Code Division Multiple Access (CDMA).** A technique for spread-spectrum multiple-access  
35 digital communications that creates channels through the use of unique code sequences.

36 **Code Symbol.** The output of an error-correcting encoder. Information bits are input to the  
37 encoder and code symbols are output from the encoder. See Convolutional Code and Turbo  
38 Code.

39 **Common Assignment Channel.** A forward common channel used by the base station to  
40 acknowledge a mobile station accessing the Enhanced Access Channel, and in the case of

1 Reservation Access Mode, to transmit the address of a Reverse Common Control Channel  
2 and associated Common Power Control Subchannel.

3 **Common Power Control Channel.** A forward common channel which transmits power  
4 control bits (i.e., common power control subchannels) to multiple mobile stations. The  
5 Common Power Control Channel is used by mobile stations when operating in the  
6 Reservation Access Mode or when the Forward Packet Data Channel is assigned without a  
7 Forward Fundamental Channel or a Forward Dedicated Control Channel.

8 **Common Power Control Subchannel.** A subchannel on the Common Power Control  
9 Channel used by the base station to control the power of a mobile station when operating  
10 in the Reservation Access Mode on the Reverse Common Control Channel or when the  
11 Forward Packet Data Channel is assigned without a Forward Fundamental Channel or a  
12 Forward Dedicated Control Channel.

13 **Convolutional Code.** A type of error-correcting code. A code symbol can be considered as  
14 the convolution of the input data sequence with the impulse response of a generator  
15 function.

16 **CRC.** See Cyclic Redundancy Code.

17 **Cyclic Redundancy Code (CRC).** A class of linear error detecting codes which generate  
18 parity check bits by finding the remainder of a polynomial division. See also Frame Quality  
19 Indicator.

20 **dBc.** The ratio (in dB) of the sideband power of a signal, measured in a given bandwidth at  
21 a given frequency offset from the center frequency of the same signal, to the total inband  
22 power of the signal. For CDMA, the total inband power of the signal is measured in a 1.23  
23 MHz bandwidth around the center frequency of the CDMA signal.

24 **dBm.** A measure of power expressed in terms of its ratio (in dB) to one milliwatt.

25 **dBm/Hz.** A measure of power spectral density. The ratio, dBm/Hz, is the power in one  
26 hertz of bandwidth, where power is expressed in units of dBm.

27 **Designated Access Mode.** A mode of operation on the Reverse Common Control Channel  
28 where the mobile station responds to requests received on the Forward Common Control  
29 Channel.

30 **Discontinuous Transmission (DTX).** A mode of operation in which a base station or a  
31 mobile station switches its transmitter or a particular code channel on and off  
32 autonomously. For the case of DTX operation on the Forward Dedicated Control Channel,  
33 the Forward Power Control Subchannel is still transmitted.

34  **$E_b$ .** The combined energy per bit at the base station RF input port. For Radio  
35 Configurations 1 and 2, this is the received energy of the Access Channel or Traffic  
36 Channel. For the Enhanced Access Channel with Radio Configurations 3 through 6, this is  
37 the combined energy of the Enhanced Access Channel and the Reverse Pilot Channel. For  
38 the Reverse Common Control Channel with Radio Configurations 3 through 6, this is the  
39 combined energy of the Reverse Common Control Channel and the Reverse Pilot Channel.  
40 For the Reverse Traffic Channel with Radio Configurations 3 through 6, this is the  
41 combined energy of the Reverse Traffic Channel, the Reverse Pilot Channel, and the

1 Reverse Power Control Subchannel. For Reverse Supplemental Channel testing, the  $E_b/N_0$   
2 requirement includes the sum of the reverse Supplemental Channel, Reverse Pilot Channel  
3 and Reverse Power Control Subchannel only and does not include the Reverse  
4 Fundamental Channel or Reverse Dedicated Control Channel. See also  $E_b/N_0$ .

5  **$E_b/N_0$** . The ratio in dB of the combined received energy per bit to the total received noise-  
6 plus-interference power in the received CDMA bandwidth divided by 1.23 MHz for  
7 Spreading Rate 1 and 3.69 MHz for Spreading Rate 3. See also  $E_b$ .

8  **$E_c/I_0$** . The ratio in dB between the pilot energy accumulated over one PN chip period ( $E_c$ )  
9 to the total power spectral density ( $I_0$ ) in the received bandwidth.

10 **Effective Isotropic Radiated Power (EIRP)**. The product of the power supplied to the  
11 antenna and the antenna gain in a direction relative to an isotropic antenna.

12 **Effective Radiated Power (ERP)**. The product of the power supplied to the antenna and  
13 the antenna gain in a direction relative to a half-wave dipole.

14 **EIRP**. See Effective Isotropic Radiated Power.

15 **Enhanced Access Channel**. A reverse channel used by the mobile for communicating to  
16 the base station. The Enhanced Access Channel operates in the Basic Access Mode, Power  
17 Controlled Access Mode, and Reservation Access Mode. It is used for transmission of short  
18 messages, such as signaling, MAC messages, response to pages, and call originations. It  
19 can also be used to transmit moderate-sized data packets.

20 **Enhanced Access Channel Preamble**. A non-data bearing portion of the Enhanced Access  
21 probe sent by the mobile station to assist the base station in initial acquisition and channel  
22 estimation.

23 **Enhanced Access Data**. The data transmitted while in the Basic Access Mode or Power  
24 Controlled Access Mode on the Enhanced Access Channel or while in the Reservation  
25 Access Mode on a Reverse Common Control Channel.

26 **Enhanced Access Header**. A frame containing access origination information transmitted  
27 immediately after the Enhanced Access Channel preamble while in the Power Controlled  
28 Access Mode or Reservation Access Mode.

29 **Enhanced Access Probe**. One Enhanced Access Channel transmission consisting of an  
30 Enhanced Access Channel preamble, optionally an Enhanced Access header, and  
31 optionally Enhanced Access data.

32 **ERP**. See Effective Radiated Power.

33 **Femto Cell**. A base station that operates at a power level of less than or equal to +20 dBm,  
34 whose operation is authorized as a function of location by a femto management server as  
35 defined in [7].

36 **FER**. Frame Error Rate of Forward Traffic Channel or Reverse Traffic Channel. The value of  
37 FER may be estimated by using Service Option 2, 9, 32, 54, or 55 (see 1.3).

38 **Forward CDMA Channel**. A CDMA Channel from a base station to mobile stations. The  
39 Forward CDMA Channel contains one or more code channels that are transmitted on a  
40 CDMA frequency assignment using a particular pilot PN offset.

1 **Forward Common Control Channel.** A control channel used for the transmission of digital  
2 control information from a base station to one or more mobile stations.

3 **Forward Dedicated Control Channel.** A portion of a Radio Configuration 3 through 9  
4 Forward Traffic Channel used for the transmission of higher-level data, control information,  
5 and power control information from a base station to a mobile station.

6 **Forward Fundamental Channel.** A portion of a Forward Traffic Channel which carries a  
7 combination of higher-level data and power control information.

8 **Forward Packet Data Channel.** A portion of a Forward Traffic Channel which carries  
9 higher-level data.

10 **Forward Packet Data Control Channel.** A control channel used for the transmission of  
11 the control information for the subpacket being transmitted on the Forward Packet Data  
12 Channel or to transmit control information.

13 **Forward Pilot Channel.** An unmodulated, direct-sequence spread spectrum signal  
14 transmitted continuously by each CDMA base station. The Pilot Channel allows a mobile  
15 station to acquire the timing of the Forward CDMA Channel, provides a phase reference for  
16 coherent demodulation, and provides means for signal strength comparisons between base  
17 stations for determining when to handoff.

18 **Forward Power Control Subchannel.** A subchannel on the Forward Fundamental  
19 Channel or Forward Dedicated Control Channel used by the base station to control the  
20 power of a mobile station when operating on the Reverse Traffic Channel.

21 **Forward Supplemental Channel.** A portion of a Radio Configuration 3 through 9 Forward  
22 Traffic Channel which operates in conjunction with a Forward Fundamental Channel or a  
23 Forward Dedicated Control Channel in that Forward Traffic Channel to provide higher data  
24 rate services, and on which higher-level data is transmitted.

25 **Forward Supplemental Code Channel.** A portion of a Radio Configuration 1 and 2  
26 Forward Traffic Channel which operates in conjunction with a Forward Fundamental  
27 Channel in that Forward Traffic Channel to provide higher data rate services, and on which  
28 higher-level data is transmitted.

29 **Forward Traffic Channel.** One or more code channels used to transport user and  
30 signaling traffic from the base station to the mobile station. See Forward Fundamental  
31 Channel, Forward Dedicated Control Channel, Forward Supplemental Channel, and  
32 Forward Supplemental Code Channel.

33 **Frame.** A basic timing interval in the system. For the Sync Channel, a frame is 26.666...  
34 ms long. For the Access Channel, the Paging Channel, the Broadcast Channel, the Forward  
35 Supplemental Code Channel, and the Reverse Supplemental Code Channel, a frame is  
36 20 ms long. For the Forward Supplemental Channel and the Reverse Supplemental  
37 Channel, a frame is 20, 40, or 80 ms long. For the Enhanced Access Channel, the Forward  
38 Common Control Channel, and the Reverse Common Control Channel, a frame is 5, 10, or  
39 20 ms long. For the Forward Fundamental Channel, Forward Dedicated Control Channel,  
40 Reverse Fundamental Channel, and Reverse Dedicated Control Channel, a frame is 5 or 20  
41 ms long. For the Common Assignment Channel, a frame is 5 ms long.

- 1 **Frame Activity.** The ratio of the number of active frames to the total number of frames  
2 during channel operation.
- 3 **Frame Quality Indicator.** The CRC check applied to 9.6 and 4.8 kbps Traffic Channel  
4 frames of Radio Configuration 1, all Forward Traffic Channel frames for Radio  
5 Configurations 2 through 9, all Reverse Traffic Channel frames for Radio Configurations 2  
6 through 6, the Broadcast Channel, Common Assignment Channel, Enhanced Access  
7 Channel, and the Reverse Common Control Channel.
- 8 **kHz.** Kilohertz ( $10^3$  Hertz).
- 9 **Line Impedance Stabilization Network (LISN).** A network inserted in the supply mains  
10 lead of apparatus to be tested that provides, in a given frequency range, a specified load  
11 impedance for the measurement of disturbance voltages and that may isolate the  
12 apparatus from the supply mains in that frequency range.
- 13 **LISN.** See Line Impedance Stabilization Network.
- 14 **Macro Cell Base Station.** A base station that is not otherwise classified as a pico cell base  
15 station or femto cell. A macro cell base station can operate at any output power, including  
16 power levels below and equal to +24 dBm.
- 17 **Mcps.** Megachips per second ( $10^6$  chips per second).
- 18 **MER.** Message Error Rate.
- 19 **Message Error Rate (MER).** The number of paging messages in error on the Paging  
20 Channel or Forward Common Control Channel divided by the total number of pages.
- 21 **MHz.** Megahertz ( $10^6$  Hertz).
- 22 **Mobile Station.** A station intended to be used while in motion or during halts at  
23 unspecified points. Mobile stations include portable units (e.g., hand-held personal units)  
24 and units installed in vehicles.
- 25 **Mobile Switching Center (MSC).** A configuration of equipment that provides cellular or  
26 PCS service.
- 27 **ms.** Millisecond ( $10^{-3}$  second).
- 28 **No.** The effective inband noise or interference power spectral density.
- 29 **Orthogonal Transmit Diversity (OTD).** A forward link transmission method which  
30 distributes forward link channel symbols among multiple antennas and spreads the  
31 symbols with a unique Walsh or quasi-orthogonal function associated with each antenna.
- 32 **OTD.** See orthogonal transmit diversity.
- 33 **Paging Channel.** A code channel in a Forward CDMA Channel used for transmission of  
34 control information and pages from a base station to a mobile station.
- 35 **Pass Band:** The range of frequencies over which a base station receiver is designed to  
36 operate and meet the requirements of operation detailed in this standard.

- 1 **Pico Cell Base Station.** An optional base station designation by the manufacturer that is  
2 permissible only when the maximum conducted output power is less than or equal to +24  
3 dBm.
- 4 **Pilot Channel.** An unmodulated, direct-sequence spread spectrum signal transmitted by a  
5 CDMA base station or mobile station. A pilot channel provides a phase reference for  
6 coherent demodulation and may provide a means for signal strength comparisons between  
7 base stations for determining when to handoff.
- 8 **Power Control Bit.** A bit, sent in every 1.25 ms interval on the Forward Traffic Channel, to  
9 signal the mobile station to increase or decrease its transmit power.
- 10 **Power Control Group.** A 1.25 ms interval on the Forward Traffic Channel and the Reverse  
11 Traffic Channel. See also Power Control Bit.
- 12 **Power Controlled Access Mode.** A mode used on the Enhanced Access Channel where a  
13 mobile station transmits an Enhanced Access preamble, an Enhanced Access header, and  
14 Enhanced Access data in the Enhanced Access probe using closed loop power control.
- 15 **Power Up Function (PUF).** A method by which the mobile station increases its output  
16 power to support location services.
- 17 **ppm.** Parts per million.
- 18 **Preamble.** See Access Channel preamble, Enhanced Access Channel preamble, Reverse  
19 Common Control Channel preamble, and Reverse Traffic Channel Preamble.
- 20 **Primary Paging Channel.** The default code channel (code channel 1) assigned for paging  
21 on a CDMA Channel.
- 22 **PUF.** See Power Up Function.
- 23 **PUF Probe.** One or more consecutive frames on the Reverse Traffic Channel within which  
24 the mobile station transmits the PUF pulse.
- 25 **PUF Pulse.** Portion of PUF probe which may be transmitted at elevated output power.
- 26 **Radio Configuration (RC).** A set of Forward Traffic Channel and Reverse Traffic Channel  
27 transmission formats that are characterized by physical layer parameters such as  
28 transmission rates, modulation characteristics, and spreading rate.
- 29 **RC.** See Radio Configuration.
- 30 **Received Signal Quality Indicator (RSQI).** A Reverse Traffic Channel measure of signal  
31 quality related to the received  $E_b/N_0$ . See also  $E_b$ .
- 32 **Reservation Access Mode.** A mode used on the Enhanced Access Channel and Reverse  
33 Common Control Channel where a mobile station transmits an Enhanced Access preamble  
34 and an Enhanced Access header in the Enhanced Access probe. The Enhanced Access data  
35 is transmitted on a Reverse Common Control Channel using closed loop power control.
- 36 **Reverse Acknowledgment Channel.** A portion of a Reverse CDMA Channel used for the  
37 transmission of acknowledgments from the mobile station to the base station in response  
38 to the data received on the Forward Packet Data Channel and the Forward Packet Data  
39 Control Channel.

1 **Reverse CDMA Channel.** The CDMA Channel from the mobile station to the base station.  
2 From the base station's perspective, the Reverse CDMA Channel is the sum of all mobile  
3 station transmissions on a CDMA frequency assignment.

4 **Reverse Channel Quality Indicator Channel.** A portion of a Reverse CDMA Channel used  
5 by the mobile station to indicate to the base station the quality of the forward link Pilot  
6 Channel received at the mobile station, and to indicate switching between base stations.

7 **Reverse Common Control Channel.** A portion of a Reverse CDMA Channel used for the  
8 transmission of digital control information from one or more mobile stations to a base  
9 station. The Reverse Common Control Channel can operate in a Reservation Access Mode  
10 or Designated Access Mode. It can be power controlled in the Reservation Access Mode or  
11 Designated Access Mode, and may support soft handoff in the Reservation Access Mode.

12 **Reverse Common Control Channel Preamble.** A non-data bearing portion of the Reverse  
13 Common Control Channel sent by the mobile station to assist the base station in initial  
14 acquisition and channel estimation.

15 **Reverse Dedicated Control Channel.** A portion of a Radio Configuration 3 through 6  
16 Reverse Traffic Channel used for the transmission of higher-level data and control  
17 information from a mobile station to a base station.

18 **Reverse Fundamental Channel.** A portion of a Reverse Traffic Channel which carries  
19 higher-level data and control information from a mobile station to a base station.

20 **Reverse Pilot Channel.** An unmodulated, direct-sequence spread spectrum signal  
21 transmitted continuously by a CDMA mobile station. A reverse pilot channel provides a  
22 phase reference for coherent demodulation and may provide a means for signal strength  
23 measurement.

24 **Reverse Supplemental Channel.** A portion of a Radio Configuration 3 through 6 Reverse  
25 Traffic Channel which operates in conjunction with the Reverse Fundamental Channel or  
26 the Reverse Dedicated Control Channel in that Reverse Traffic Channel to provide higher  
27 data rate services, and on which higher-level data is transmitted.

28 **Reverse Supplemental Code Channel.** A portion of a Radio Configuration 1 and 2 Reverse  
29 Traffic Channel which operates in conjunction with the Reverse Fundamental Channel in  
30 that Reverse Traffic Channel, and (optionally) with other Reverse Supplemental Code  
31 Channels to provide higher data rate services, and on which higher-level data is  
32 transmitted.

33 **Reverse Traffic Channel.** A traffic channel on which data and signaling are transmitted  
34 from a mobile station to a base station. The Reverse Traffic Channel is composed of up to  
35 one Reverse Dedicated Control Channel, up to one Reverse Fundamental Channel, zero to  
36 two Reverse Supplemental Channels, and zero to seven Reverse Supplemental Code  
37 Channels.

38 **Reverse Traffic Channel Preamble.** A non-data bearing portion of the Reverse Pilot  
39 Channel sent by the mobile station to aid the base station in initial acquisition and channel  
40 estimation for the Reverse Dedicated Control Channel and Reverse Fundamental Channel.

41 **RMS.** Root of Mean Square.

- 1 **RSQI.** See Received Signal Quality Indicator.
- 2 **Service Option 2.** Loopback service option for Radio Configuration 1 as specified in [5].
- 3 **Service Option 9.** Loopback service option for Radio Configuration 2 as specified in [5].
- 4 **Service Option 32.** Test data service option for Radio Configurations 3 through 6 on the  
5 Reverse Traffic Channel and Radio Configurations 3 through 9 on the Forward Traffic  
6 Channel as specified in [6].
- 7 **Service Option 54.** Markov service option for Radio Configurations 1 through 6 on the  
8 Reverse Traffic Channel and Radio Configurations 1 through 9 on the Forward Traffic  
9 Channel as specified in [7].
- 10 **Service Option 55.** Loopback service option for Radio Configurations 1 through 6 on the  
11 Reverse Traffic Channel and Radio Configurations 1 through 9 on the Forward Traffic  
12 Channel as specified in [5].
- 13 **Space Time Spreading (STS).** A forward link transmission method which transmits all  
14 forward link channel symbols on multiple antennas and spreads the symbols with  
15 complementary Walsh or quasi-orthogonal functions.
- 16 **Spreading Rate (SR).** The PN chip rate of the Forward CDMA Channel or the Reverse  
17 CDMA Channel, defined as a multiple of 1.2288 Mcps.
- 18 **Spreading Rate 1.** Spreading Rate 1 is often referred to as “1X.” A Spreading Rate 1  
19 Forward CDMA Channel uses a single direct-sequence spread carrier with a chip rate of  
20 1.2288 Mcps. A Spreading Rate 1 Reverse CDMA Channel uses a single direct-sequence  
21 spread carrier with a chip rate of 1.2288 Mcps.
- 22 **Spreading Rate 3.** Spreading Rate 3 is often referred to as “3X.” A Spreading Rate 3  
23 Forward CDMA Channel uses three direct-sequence spread carriers (see Multiple-Carrier  
24 Forward Channel) each with a chip rate of 1.2288 Mcps. A Spreading Rate 3 Reverse CDMA  
25 Channel uses a single direct-sequence spread carrier with a chip rate of 3.6864 Mcps.
- 26 **SR.** See Spreading Rate.
- 27 **STS.** See Space Time Spreading.
- 28 **Subpacket Data Rate.** The data rate for a subpacket transmission of the Forward Packet  
29 Data Channel. The subpacket data rate is equal to the number of bits in the encoder  
30 packet divided by the duration of the subpacket transmission.
- 31 **Sync Channel.** Code channel 32 in the Forward CDMA Channel, which transports the  
32 synchronization message to the mobile station.
- 33 **System Time.** The time reference used by the system. System Time is synchronous to UTC  
34 time (except for leap seconds) and uses the same time origin as Global Positioning System  
35 (GPS) time. All base stations use the same System Time (within a small error). Mobile  
36 stations use the same System Time, offset by the propagation delay from the base station  
37 to the mobile station. See also Universal Coordinated Time.
- 38 **TD.** Transmit Diversity schemes, including OTD and STS.

1 **Traffic Channel.** A communication path between a mobile station and a base station used  
2 for user and signaling traffic. The term Traffic Channel implies a Forward Traffic Channel  
3 and Reverse Traffic Channel pair. See also Forward Traffic Channel and Reverse Traffic  
4 Channel.

5 **Transmit Diversity Pilot Channel.** An unmodulated, direct-sequence spread spectrum  
6 signal transmitted continuously by a CDMA base station to support forward link transmit  
7 diversity. The pilot channel and the transmit diversity pilot channel provide phase  
8 references for coherent demodulation of forward link CDMA channels which employ  
9 transmit diversity.

10 **Turbo Code.** A type of error-correcting code. A code symbol is based on the outputs of the  
11 two recursive convolutional codes (constituent codes) of the Turbo code.

12 **Universal Coordinated Time (UTC).** An internationally agreed-upon time scale maintained  
13 by the Bureau International de l'Heure (BIH) used as the time reference by nearly all  
14 commonly available time and frequency distribution systems, e.g., WWV, WWVH, LORAN-  
15 C, Transit, Omega, and GPS.

16 **UTC.** Universal Temps Coordoné. See Universal Coordinated Time.

17 **Valid Power Control Bit.** A valid power control bit is sent on the Forward Traffic Channel  
18 in the second power control group following the corresponding Reverse Traffic Channel  
19 power control group which was not gated off and in which the signal was estimated. See  
20 3.1.3.1.10 of [3].

21 **Walsh Function.** One of  $2^N$  time orthogonal binary functions (note that the functions are  
22 orthogonal after mapping '0' to 1 and '1' to -1).

### 23 **1.3 Test Modes**

24 The Forward Traffic Channel and Reverse Traffic Channel are verified by invoking  
25 Fundamental Channel test modes, Dedicated Control Channel test modes, Supplemental  
26 Channel test modes, and Supplemental Code Channel test modes. Table 1.3-1 lists the test  
27 modes and the mapping to radio configurations.

28

**Table 1.3-1. Test Configuration Combinations**

<b>Test Mode</b>	<b>Forward Traffic Channel Radio Configuration</b>	<b>Reverse Traffic Channel Radio Configuration</b>
1	1	1
2	2	2
3	3	3
4	4	3
5	5	4
6	6	5
7	7	5
8	8	6
9	9	6
10a	10	3
10b	10	7

Note: Test Mode 10b is not applicable to this standard and is included for information only. Test Mode 10b will be applicable in the next revision of this Standard.

2

3 Fundamental Channel Test Mode 1 is entered by setting up a call using the Loopback  
4 Service Option (Service Option 2 or 55) or the Markov Service Option (Service Option 54).  
5 Supplemental Code Channel Test Mode 1 is entered by setting up a call using the  
6 Loopback Service Option (Service Option 30).

7 Fundamental Channel Test Mode 2 is entered by setting up a call using the Loopback  
8 Service Option (Service Option 9 or 55) or the Markov Service Option (Service Option 54).  
9 Supplemental Code Channel Test Mode 2 is entered by setting up a call using the  
10 Loopback Service Option (Service Option 31).

11 Fundamental Channel Test Modes 3 through 9 are entered by setting up a call using the  
12 Loopback Service Option (Service Option 55), Markov Service Option (Service Option 54), or  
13 Test Data Service Option (Service Option 32).

14 Dedicated Control Channel Test Modes 3 through 9, Supplemental Channel Test Modes 3  
15 through 9, and Packet Data Test Mode 10a are entered by setting up a call using the Test  
16 Data Service Option (Service Option 32).

17 The Reverse Channel Quality Indicator Channel and Reverse Acknowledgement Channel  
18 are verified by invoking the Channel Quality Indicator Channel Test Mode, and Reverse  
19 Acknowledgment Channel Test Modes.

20 The Channel Quality Indicator Channel Test Mode is entered by setting up a call using Test  
21 Data Service Option (Service Option 32). The base station shall send an appropriate  
22 Service Option Control Message in which CQI\_TEST\_MODE is set to '0001'.

- 1 The Reverse Acknowledgment Channel Test Mode is entered by setting up a call using Test
- 2 Data Service Option (Service Option 32). The base station shall send an appropriate
- 3 Service Option Control Message in which ACK\_TEST\_MODE is set to '0001'.

4

## 2 STANDARD EMISSIONS MEASUREMENT PROCEDURES

The measurement and calibration procedures described are intended to provide an overview of radiated and conducted signal measurements. A detailed description of the required measurement procedures is given in [1].

### 2.1 Radiated Emissions Measurement

#### 2.1.1 Standard Radiation Test Site

The test site shall be on level ground that is of uniform electrical characteristics. The site shall be clear of metallic objects, overhead wires, etc., and shall be as free as possible from undesired signals, such as ignition noise and other carriers. Reflecting objects, such as rain gutters and power cables, shall lie outside an ellipse measuring 60 meters on the major axis by 52 meters on the minor axis for a 30-meter site, or an ellipse measuring 6 meters on the major axis by 5.2 meters on the minor axis for a 3-meter site. The equipment under test shall be located at one focus of the ellipse and the measuring antenna at the other focus. If desired, shelters may be provided at the test site to protect the equipment and personnel. All such construction shall be of wood, plastic, or other non-metallic material. All power, telephone, and control circuits to the site shall be buried at least 0.3 meter under ground.

A turntable, essentially flush with the ground, shall be provided that can be remotely controlled. A platform 1.2 meters high shall be provided on this turntable to hold the equipment under test. Any power and control cables that are used for this equipment should extend down to the turntable, and any excess cabling should be coiled on the turntable.

If the equipment to be tested is mounted in racks and is not easily removed for testing on the above platform, then the manufacturer may elect to test the equipment when it is mounted in its rack (or racks). In this case, the rack (or racks) may be placed directly on the turntable.

If a transmitter with an external antenna is being tested, then the RF output of this transmitter shall be terminated in a non-radiating load that is placed on the turntable. A non-radiating load is used in lieu of an antenna to avoid interference with other radio users. The RF cable to this load should be of minimum length. The transmitter shall be tuned and adjusted to its rated output value before starting the tests.

In order to conduct unintentional radiator tests as specified in Part 15, subpart B of [2], the radiation site must comply with Sections 5.4.6 through 5.5 of [1] as required by Part 2.948 of [2].

#### 2.1.2 Search Antenna

For narrow-band dipole adjustable search antennas, the dipole length shall be adjusted for each measurement frequency. This length may be determined from a calibration ruler that is normally supplied with the equipment.

1 The search antenna shall be mounted on a movable non-metallic horizontal boom that can  
2 be raised or lowered on a wooden or other non-metallic pole. The cable connected to the  
3 search antenna shall be at a right angle to the antenna. The cable shall be dressed at least  
4 3 meters, either through or along the horizontal boom, in a direction away from the  
5 equipment being measured. The search antenna cable may then be dropped from the end  
6 of the horizontal boom to ground level for connection to the field-strength measuring  
7 equipment.

8 The search antenna shall be capable of being rotated 90 degrees on the end of the  
9 horizontal boom to allow measurement of both vertically and horizontally polarized signals.  
10 When the antenna length of a vertically mounted antenna does not permit the horizontal  
11 boom to be lowered to its minimum specified search range, adjust the minimum height of  
12 the boom for 0.3 meter clearance between the end of the antenna and the ground.

### 13 2.1.3 Field-Strength Measurement

14 A field-strength meter shall be connected to a search antenna. The field-strength meter  
15 shall have sufficient sensitivity and selectivity to measure signals over the required  
16 frequency ranges at levels at least 10 dB below the levels specified in any document,  
17 standard, or specification that references this measurement procedure. The calibration of  
18 the measurement instruments (field-strength meter, antennas, etc.) shall be checked  
19 frequently to ensure that their accuracy is in accordance with the current standards. Such  
20 calibration checks shall be performed at least once per year.

### 21 2.1.4 Frequency Range of Measurements

22 When measuring radiated signals from transmitting equipment, the measurements shall be  
23 made from the lowest radio frequency (but no lower than 25 MHz) generated in the  
24 equipment to the tenth harmonic of the carrier, except for that region close to the carrier  
25 equal to  $\pm 250\%$  of the authorized bandwidth.

26 When measuring radiated signals from receiving equipment, the measurements shall be  
27 made from 25 MHz to at least 6 GHz.

### 28 2.1.5 Test Ranges

#### 29 2.1.5.1 30-Meter Test Range

30 Measurement of radiated signals shall be made at a point 30 meters from the center of the  
31 turntable. The search antenna is to be raised and lowered from 1 to 4 meters in both  
32 horizontally and vertically polarized orientations.

33 The field-strength measuring meter may be placed on a suitable table or tripod at the foot  
34 of the mast.

35 When measuring radiated emissions from receivers, equipment that contains its own  
36 receive antenna shall be tested with the antenna in place. Equipment that is connected to  
37 an external receive antenna via a cable shall be tested without the antenna, and the receive  
38 ports on the equipment under test shall be terminated in a  $50\Omega$  non-radiating resistive  
39 load.

### 1 2.1.5.2 3-Meter Test Range

2 Measurement of radiated signals may be made at a point 3 meters from the center of the  
3 turntable, provided the following three conditions can be met:

- 4 1. A ground screen that covers an elliptical area at least 6 meters on the major axis  
5 by 5.2 meters on the minor axis is used, with the measuring antenna and  
6 turntable mounted 3 meters apart. The measuring antenna and turntable shall lie  
7 on the major axis and shall be equidistant from the minor axis of the elliptical  
8 area.
- 9 2. The maximum dimension of the equipment shall be 3 meters or less. When  
10 measuring radiated signals from receivers, the maximum dimension shall include  
11 the antenna if it is an integral part of the device.
- 12 3. The field-strength measuring equipment is either mounted below the ground level  
13 at the test site or is located a sufficient distance away from the equipment being  
14 tested and from the search antenna to prevent corruption of the measured data.

15 The search antenna is to be raised and lowered over a range from 1 to 4 meters in both  
16 horizontally and vertically polarized orientations. When the search antenna is vertically  
17 oriented, the minimum height of the center of the search antenna shall be defined by the  
18 length of the lower half of the search antenna.

19 When measuring radiated emissions from receivers, equipment that contains its own  
20 receive antenna shall be tested with the antenna in place. Equipment that is connected to  
21 an external receive antenna via a cable shall be tested without the antenna, and the receive  
22 ports on the equipment under test shall be terminated in a 50Ω non-radiating resistive  
23 load. The 3-meter test range may be used for determining compliance with limits specified  
24 at 30 meters (or other distances), provided that:

- 25 1. The ground reflection variations between the two distances have been calibrated for  
26 the frequencies of interest at the test range, or
- 27 2. A 5 dB correction factor is added to the specified radiation limit(s) to allow for  
28 average ground reflections.

29 Radiated field strength (volt/meter) varies inversely with distance, so that a measurement  
30 made on the 3-meter test range divided by 10 gives the equivalent value that would be  
31 measured on a 30-meter test range for the same EIRP (effective isotropic radiated power).  
32 The 30-meter field strength in volt/meter can be calculated from the EIRP by using the  
33 following formula:

$$34 \quad \mu\text{V/m @ 30 meters} = 5773.5 \times 10^{\text{EIRP(dBm)}/20}$$

### 35 2.1.6 Radiated Signal Measurement Procedures

36 Radiated signals having significant levels shall be measured on the 30-meter or 3-meter  
37 test range by using the following procedure:

- 38 1. For each observed radiated signal, raise and lower the search antenna to obtain a  
39 maximum reading on the field-strength meter with the antenna horizontally  
40 polarized. Then rotate the turntable to maximize the reading. Repeat this

- 1 procedure of raising and lowering the antenna and rotating the turntable until the  
2 highest possible signal has been obtained. Record this maximum reading.
- 3 2. Repeat step 1 for each observed radiated signal with the antenna vertically  
4 polarized.
- 5 3. Remove the equipment being tested and replace it with a half-wave antenna. The  
6 center of the half-wave antenna should be at the same approximate location as the  
7 center of the equipment being tested.
- 8 4. Feed the half-wave antenna replacing the equipment under test with a signal  
9 generator connected to the antenna by means of a non-radiating cable. With the  
10 antennas at both ends horizontally polarized and with the signal generator tuned  
11 to the observed radiated signal, raise and lower the search antenna to obtain a  
12 maximum reading on the field-strength measuring meter. Adjust the level of the  
13 signal generator output until the previously recorded maximum reading for this set  
14 of conditions is obtained. Record the signal generator power output.
- 15 5. Repeat step 4 above with both antennas vertically polarized.
- 16 6. Calculate the power into a reference ideal isotropic antenna by:
- 17 a. First reducing the readings obtained in steps 4 and 5 above by the power loss  
18 in the cable between the generator and the source antenna, and
- 19 b. Then correcting for the gain of the source antenna used relative to an ideal  
20 isotropic antenna. The reading thus obtained is the equivalent effective  
21 isotropic radiated power (EIRP) level for the spurious signal being measured.
- 22 7. Repeat steps 1 through 6 above for all observed signals from the equipment being  
23 tested.

## 24 **2.2 AC Power Line Conducted Emissions Measurement**

### 25 2.2.1 Standard AC Power Line Conducted Emissions Test Site

26 The test site shall be on level ground that is covered with an earth-grounded, conductive  
27 surface that is at least 2 meters by 2 meters in size. The ground plane shall extend at least  
28 0.5 meter beyond the foot print of the equipment under test.

29 A vertical conducting plane is optional for a standard (open area) test site and is only  
30 required for measurements made on table top devices. If a vertical conducting plane is  
31 used, it shall be at least 2 meters by 2 meters in size and shall be electrically attached to  
32 the conductive ground plane at maximum intervals of one meter along its entire length.

### 33 2.2.2 Line Impedance Stabilization Network (LISN) Unit

34 A Line Impedance Stabilization Network (LISN) shall be used for equipment that is tested  
35 on a standard test site and connects directly to the public utility power line, or receives  
36 power from a device that connects to the public utility power line. The LISN shall be placed  
37 on top of or directly underneath the conductive ground plane and shall be electrically  
38 grounded to it. Power line filters between the power source and LISN may be used to  
39 reduce the ambient noise level on the public utility line.

### 2.2.3 Standard Test Site Measurements

#### 2.2.3.1 Floor Standing Equipment

Floor standing equipment shall be placed directly on the conductive ground plane. If a vertical conducting plane is used, the equipment under test shall be located 40 cm from the vertical conducting surface. All other conductive objects (including the LISN) shall be located at least 80 cm from any surface on the equipment under test.

#### 2.2.3.2 Table Top Mounted Equipment

Table top equipment shall be placed on top of a non-conductive platform, with nominal long dimension of 1.5 meters, and located 80 cm above the horizontal conducting ground plane. The equipment under test shall be placed 40 cm from the vertical conductive surface, with all other conductive objects located at least 80 cm from any surface on the equipment under test.

#### 2.2.3.3 Measurement Procedure

A radio noise meter employing a quasi-peak detector shall be used to test for radio noise between each current carrying conductor and the ground conductor. Each current carrying conductor shall be tested individually with all unused connections on the LISN terminated in a 50 $\Omega$  resistive load. The ground (safety) conductor on the equipment under test shall be individually connected to the power source through the LISN. Any adapters used between the LISN power socket and the equipment under test shall be no more than 20 cm long and shall contain only one input and only one output.

The equipment under test shall be tested in various modes of operation with numerous cable orientations. The emissions level shall be recorded for the mode of operation and cable orientation that maximizes the radio noise level. This maximizing technique shall be repeated for measurements on each current carrying conductor.

#### 2.2.3.4 Frequency Range of Measurements

When measuring AC power line conducted emissions, the measurements shall be made at frequencies between 450 kHz and 30 MHz.

### 2.2.4 End User or Manufacturing Plant Test Sites

For equipment that cannot be tested at a standard (open area) test site, an AC power line conducted emissions test may be performed at the end user's location or at the manufacturing plant. Refer to Section 5.6 of [1] for specifications and requirements of such tests.

1 This page intentionally left blank.

2

### 3 CDMA RECEIVER MINIMUM STANDARDS

All CDMA base station receiving equipment shall include two diversity RF input ports, except Femto Cells. Femto Cells may have either one or two RF input ports. Receiver tests on equipment that includes two input ports shall employ both inputs, unless otherwise specified. The equipment setups referenced in this section are functional. Other configurations may be necessary for actual testing due to equipment limitations and tolerances.

#### 3.1 Frequency Coverage Requirements

The RF channel numbers and frequencies are given for CDMA base stations and mobile stations in [8]. The base station receive CDMA frequency assignments are associated on a one-to-one basis with transmit CDMA frequency assignments. Each CDMA frequency assignment shall be centered at one of the indicated frequencies. The base station receiver may be fixed tuned to a specific CDMA frequency assignment or may be designed to cover a subset of the available frequency assignments. The base station shall support at least one of the preferred CDMA channels for each band class supported.

#### 3.2 Access Probe Acquisition

These tests shall be performed for the Access Channel and the Enhanced Access Channel, if supported. For Femto Cells with one RF input port, these tests are not specified.

##### 3.2.1 Definition

Access Channel and Enhanced Access Channel access probe acquisition is measured by the probability of successful access per probe at specified values of received  $E_b/N_0$ .

##### 3.2.2 Method of Measurement

Refer to Figure 6.5.1-1<sup>1</sup> for a functional block diagram of the test setup.

##### 3.2.2.1 Access Channel Probe Acquisition

1. Configure the base station under test and a mobile station simulator as shown in Figure 6.5.1-1.
2. For each band class that the base station supports, configure the base station to operate in that band class and perform steps 3 through 11.
3. Adjust the Additive White Gaussian Noise (AWGN) generators so that the noise power at each base station RF input port is at least -90 dBm/1.23 MHz.

---

<sup>1</sup> For Femto Cells with one input port, only one of the two Rx inputs into the Base Station under test in the figure shall be used.

- 1           4. Set the fields of the *Access Parameters Message* as follows:

2

<b>Field</b>	<b>Value (Decimal)</b>
ACC_CHAN	0
NOM_PWR	0
INIT_PWR	0
PWR_STEP	0
NUM_STEP	6
MAX_REQ_SEQ	1
MAX_RSP_SEQ	1
Remaining Parameters	As specified by manufacturer

3

- 4           5. Disable all forms of registration.

- 5           6. Retrieve the initial number of Access Channel access attempts from the  
6           mobile station simulator. This may be done by using the *Retrieve Parameters*  
7           *Message*.

- 8           7. Adjust the equipment so that the Access Channel access probe  $E_b/N_0$  at each  
9           RF input port is less than the value derived from log-linear interpolation of  
10           the endpoints values given in Table A.1-1.

- 11          8. Page the mobile station simulator. The  $E_b/N_0$  of the forward link at the  
12          mobile station simulator should be sufficiently high so that the message error  
13          rate is negligible.

- 14          9. Retrieve the total number of Access Channel access attempts from the mobile  
15          station simulator.

- 16          10. Compute the Access Channel probe failure rate from the number of attempts  
17          and the number of successes recorded by the base station.

- 18          11. Repeat steps 8 through 10 until a pass or fail condition has been achieved in  
19          accordance with the confidence calculation described in 6.8.

#### 20   3.2.2.2 Enhanced Access Channel Probe Acquisition

- 21          1. Configure the base station under test and a mobile station simulator as  
22          shown in Figure 6.5.1-1<sup>2</sup>.

---

<sup>2</sup> For Femto Cells with one input port, only one of the two Rx inputs into the Base Station under test in the figure shall be used.

- 1 2. For each band class that the base station supports, configure the base
- 2 station to operate in that band class and perform steps 3 through 16.
- 3 3. Adjust the Additive White Gaussian Noise (AWGN) generators so that the
- 4 noise power at each base station RF input port is at least -90 dBm/1.23 MHz
- 5 for Spreading Rate 1 or -85 dBm/3.69 MHz for Spreading Rate 3.
- 6 4. Set the fields of the *Enhanced Access Parameters Message* as follows:

7

Field	Value (Decimal)
MAX_REQ_SEQ	1 (1 origination probe sequence)
MAX_RSP_SEQ	1 (1 page response probe sequence)
NUM_MODE_SELECTION_ENTRIES	0 (only one access mode specified)
ACCESS_MODE	0 (Basic Access Mode)
ACCESS_MODE_MIN_DURATION	0 (0 seconds)
ACCESS_MODE_MAX_DURATION	1024 (5.12 seconds maximum message duration)
NUM_MODE_PARAM_REC	0 (only Basic Access Mode specific parameter records)
APPLICABLE_MODES	1 (parameters are for Basic Access Mode)
NUM_EACH_BA	1 (one Enhanced Access Channel)
EACH_BA_RATES_SUPPORTED	0 (9600 bps, 20 ms frame size)
Remaining Parameters	As specified by manufacturer

8

- 9 5. Disable all forms of registration.
- 10 6. If the base station supports demodulation with Spreading Rate 1, configure
- 11 the base station so that the mobile station simulator uses the Spreading Rate
- 12 1 Enhanced Access Channel and perform steps 8 through 16.
- 13 7. If the base station supports demodulation with Spreading Rate 3, configure
- 14 the base station so that the mobile station simulator uses the Spreading Rate
- 15 3 Enhanced Access Channel and perform steps 8 through 16.
- 16 8. Configure the mobile station simulator to send the test message, a *Data Burst*
- 17 *Message* containing 255 CHARi fields of valid data, to the base station when
- 18 specified.
- 19 9. Retrieve the initial number of Enhanced Access Channel access attempts
- 20 from the mobile station simulator. This may be done by using the *Retrieve*
- 21 *Parameters Message*.

- 1       10. Adjust the equipment so that the Enhanced Access Channel access probe  
2            $E_b/N_0$  at each RF input port is no more than the desired value shown in  
3           Table A.1-2.
- 4       11. Trigger the mobile station simulator to send the test message to the base  
5           station. The  $E_b/N_0$  of the forward link at the mobile station simulator should  
6           be sufficiently high so that the message error rate is negligible.
- 7       12. Retrieve the total number of Enhanced Access Channel access attempts from  
8           the mobile station simulator.
- 9       13. Compute the Enhanced Access Channel probe failure rate from the number  
10           of attempts and the number of successes recorded by the base station.
- 11      14. Repeat steps 11 through 13 until a pass or fail condition has been achieved  
12           in accordance with the confidence calculation described in 6.8.
- 13      15. Configure the mobile station simulator to send the test message, an  
14           *Origination Message*, to the base station when specified.
- 15      16. Repeat steps 9 through 14.

### 16   3.2.3 Minimum Standard

17   The Access Channel access probe failure rate shall be less than the maximum values  
18   shown in Table A.1-1 with 90% confidence (see 6.8).

19   If the base station supports the Enhanced Access Channel, the access probe failure  
20   rate shall be less than the maximum values shown in Table A.1-2 with 90%  
21   confidence (see 6.8).

## 22   **3.3 Reverse Common Control Channel Demodulation Performance**

23   The tests in this section verify the demodulation performance of Reverse Common  
24   Control Channel under AWGN and fading conditions.

### 25   3.3.1 Performance in Additive White Gaussian Noise

#### 26   3.3.1.1 Definition

27   The demodulation performance of the Reverse Common Control Channel in an AWGN  
28   (no fading or multipath) environment is determined by the frame error rate (FER) at  
29   specified values of  $E_b/N_0$ . The FER is calculated for each data rate and frame length  
30   configuration supported by the base station. Refer to 6.7 for the definition of Reverse  
31   Common Control Channel FER.

32   When operating in the Reservation Access Mode, the base station monitors the  
33   Reverse Common Control Channel after transmitting the *Early Acknowledgement*  
34   *Channel Assignment Message* to the mobile station. Power control of the Common  
35   Power Control Channel is disabled for these tests. The following tests verify that the  
36   base station has proper demodulation performance of the Reverse Common Control  
37   Channel in an AWGN (no fading or multipath) environment.

1 3.3.1.2 Method of Measurement

2 Refer to Figure 6.5.1-1 for a functional block diagram of the test setup.

- 3 1. Configure the base station under test and a mobile station simulator as  
4 shown in Figure 6.5.1-1<sup>3</sup>.
- 5 2. For each band class that the base station supports, configure the base  
6 station to operate in that band class and perform steps 3 through 18.
- 7 3. Adjust the AWGN generators to yield a noise power spectral density of -84  
8 dBm/1.23 MHz  $\pm$ 5 dB for Spreading Rate 1 or -79 dBm/3.69 MHz  $\pm$ 5 dB for  
9 Spreading Rate 3, at each base station receiver input.
- 10 4. Adjust the equipment so that the Reverse Common Control Channel  $E_b/N_0$  at  
11 each RF input port is within the range specified in Table A.2.1-1. The  
12 Common Power Control Channel power control of the Reverse Common  
13 Control Channel in the mobile station simulator shall be disabled (see 6.4.3).
- 14 5. Set the following values in the *Enhanced Access Parameters Message*:

15

Parameter	Value (Decimal)
ACCESS_MODE	1 (Reservation Access Mode)
APPLICABLE_MODES	1 (Parameters are for Reservation Access Mode)
ACCESS_MODE_MIN_DURATION	0 (0 seconds)
ACCESS_MODE_MAX_DURATION	1024 (5.12 seconds)
NUM_EACH_RA	1 (1 EACH for Reservation Access Mode)
EACH_RA_RATES_SUPPORTED	1 (9600 bps, 20 ms frame size)
NUM_CACH	1 (1 CACH)
CACH_CODE_RATE	0 (CACH operating in Spreading Rate 1; CACH Code Rate is 1/4)
NUM_RCCCH	1 (1 R-CCCH)
RCCCH_RATES_SUPPORTED	Set as required for each test
RCCCH_SLOT_OFFSET1	0 (no offset)
RCCCH_SLOT_OFFSET2	0 (no offset)
RCCCH_NOM_PWR	0 (0 dB)
RCCCH_INIT_PWR	0 (0 dB)

---

<sup>3</sup> For Femto Cells with one input port, only one of the two Rx inputs into the Base Station under test in the figure shall be used.

RCCCH_HANDOFF_SUPPORTED	0 (no R-CCCH handoff allowed)
RA_CPCCH_STEP_UP	0 (disable R-CCCH power control)
RA_CPCCH_STEP_DN	0 (disable R-CCCH power control)

1  
2  
3  
4  
5  
6  
7  
8  
9  
10  
11  
12  
13  
14  
15  
16  
17  
18  
19  
20  
21  
22  
23  
24  
25  
26  
27  
28  
29  
30  
31  
32  
33  
34  
35  
36

6. If the base station supports demodulation with Spreading Rate 1, configure the base station so that the mobile station simulator uses the Spreading Rate 1 Reverse Common Control Channel and perform steps 8 through 18.
7. If the base station supports demodulation with Spreading Rate 3, configure the base station so that the mobile station simulator uses the Spreading Rate 3 Reverse Common Control Channel and perform steps 8 through 18.
8. Configure the mobile station simulator to send a Reservation Access Enhanced Access Probe with the Enhanced Access Channel Header parameter RATE\_WORD set to "0" (9600 bps, 20 ms frame) and perform steps 14 through 18.
9. If the base station supports 19200 bps, 10 ms frame size operation on the Reverse Common Control Channel, configure the mobile station simulator to send a Reservation Access Enhanced Access Probe with the Enhanced Access Channel Header parameter RATE\_WORD set to "2" (19200 bps, 10 ms frame) and perform steps 14 through 18.
10. If the base station supports 19200 bps, 20 ms frame size operation on the Reverse Common Control Channel, configure the mobile station simulator to send a Reservation Access Enhanced Access Probe with the Enhanced Access Channel Header parameter RATE\_WORD set to "1" (19200 bps, 20 ms frame) and perform steps 14 through 18.
11. If the base station supports 38400 bps, 20 ms frame size operation on the Reverse Common Control Channel, configure the mobile station simulator to send a Reservation Access Enhanced Access Probe with the Enhanced Access Channel Header parameter RATE\_WORD set to "3" (38400 bps, 20 ms frame) and perform steps 14 through 18.
12. If the base station supports 38400 bps, 10 ms frame size operation on the Reverse Common Control Channel, configure the mobile station simulator to send a Reservation Access Enhanced Access Probe with the Enhanced Access Channel Header parameter RATE\_WORD set to "4" (38400 bps, 10 ms frame) and perform steps 14 through 18.
13. If the base station supports 38400 bps, 5 ms frame size operation on the Reverse Common Control Channel, configure the mobile station simulator to send a Reservation Access Enhanced Access Probe with the Enhanced Access Channel Header parameter RATE\_WORD set to "5" (38400 bps, 5 ms frame) and perform steps 14 through 18.

- 1 14. Once the end of the Enhanced Access Channel Header is detected, send an  
 2 *Early Acknowledgement Channel Assignment Message* on the Common  
 3 Assignment Channel addressed to the mobile station simulator.
- 4 15. Transmit the Reverse Common Control Channel at the level specified in step  
 5 3 to ensure the  $E_b/N_0$  at each RF input port is within the specified limits.
- 6 16. Send pseudo-random test data to the base station.
- 7 17. Measure the frame error rate as described in 6.7. 18. Repeat steps 14-17  
 8 until the required test confidence level is met.

### 9 3.3.1.3 Minimum Standard

10 With 95% confidence (see 6.8), the FER for each data rate shall not exceed that given  
 11 by linear interpolation on a  $\log_{10}$  scale between the two values given in Table A.2.1-2  
 12 at the larger of the  $E_b/N_0$  values at the two RF input ports, or at  $E_b/N_0$  at the RF  
 13 input port in the case of Femto Cells with single RF input ports. The interpolated  
 14 value,  $FER_{lim}$ , is given by

$$15 \quad \log_{10}(FER_{lim}) = \log_{10}(FER_{upper}) \\ + \left( \frac{(E_b/N_0)_{upper} - (E_b/N_0)_{meas}}{(E_b/N_0)_{upper} - (E_b/N_0)_{lower}} \right) \times [\log_{10}(FER_{lower}) - \log_{10}(FER_{upper})]$$

16 where the subscripts 'upper' and 'lower' refer to  $E_b/N_0$  limits described in 3.3.1.2 and  
 17 FER entries in Table A.2.1-2.  $(E_b/N_0)_{meas}$  is the measured value in dB.

### 18 3.3.2 Performance in Multipath Fading with Closed Loop Power Control

#### 19 3.3.2.1 Definition

20 The performance of the demodulation of Reverse Common Control Channel with  
 21 closed loop power control in a multipath fading environment is determined by the  
 22 frame error rate (FER) at specified values of  $E_b/N_0$ . The FER is calculated for each  
 23 data rate and frame length configuration supported by the base station. Refer to 6.7  
 24 for the definition of Reverse Common Control Channel FER. For Femto Cells with one  
 25 RF input port, these tests are not specified..

#### 26 3.3.2.2 Method of Measurement

27 Refer to Figure 6.5.1-2 for a functional block diagram of the test setup.

- 28 1. Configure both the base station under test and a mobile station simulator as  
 29 shown in Figure 6.5.1-2<sup>4</sup>.
- 30 2. For each band class that the base station supports, configure the base  
 31 station to operate in that band class and perform steps 3 through 16.

---

<sup>4</sup> For Femto Cells with one input port, only one of the two Rx inputs into the Base Station under test in the figure shall be used.

- 1        3. Adjust the AWGN generators to yield a noise power spectral density of -84  
2        dBm/1.23 MHz ±5 dB for Spreading Rate 1 or -79 dBm/3.69 MHz ±5 dB for  
3        Spreading Rate 3, at each base station receiver input.
- 4        4. For each case in Table A.2.2-1 specified for the radio configuration under  
5        test, adjust the equipment so that the mean Reverse Common Control  
6        Channel  $E_b/N_0$  at each RF input port is within the range specified in Table  
7        A.2.2-1. Reverse Common Control Channel closed loop power control in the  
8        mobile station simulator shall be enabled. The channel simulator  
9        configurations (see 6.4.1) for each case are as follows:

Case	Channel Simulator Configuration
A	1 (3 km/h, 1 path)
B	2 (8 km/h, 2 paths)
C	3 (30 km/h, 1 path)
D	4 (100 km/h, 3 path)

- 11        Tests using Case D are not required for Pico Cell base stations.
- 12        Tests for Femto Cells with two antennas are limited to only Cases A and C.
- 13        5. Set the following values in the *Enhanced Access Parameters Message*:

Parameter	Value (Decimal)
ACCESS_MODE	1 (Reservation Access Mode)
APPLICABLE_MODES	1 (Parameters are for Reservation Access Mode)
ACCESS_MODE_MAX_DURATION	1024 (5.12 seconds)
RA_CPCCH_STEP_UP	2 (1 dB)
RA_CPCCH_STEP_DN	2 (1 dB)
RCCCH_RATES_SUPPORTED	[Set per base station support]
Remaining Parameters	As specified by manufacturer

- 15
- 16        6. If the base station supports demodulation of Spreading Rate 1, configure the  
17        base station so that the mobile station simulator uses the Spreading Rate 1  
18        Reverse Common Control Channel and perform steps 8 through 16.
- 19        7. If the base station supports demodulation of Spreading Rate 3, configure the  
20        base station so that the mobile station simulator uses the Spreading Rate 3  
21        Reverse Common Control Channel and perform steps 8 through 16.

- 1 8. Configure the mobile station simulator to send a Reservation Access  
 2 Enhanced Access Probe with the Enhanced Access Channel Header  
 3 parameter RATE\_WORD set to “0” (9600 bps, 20 ms frame) and perform steps  
 4 12 through 16.
- 5 9. If the base station supports 19200 bps, 10 ms frame size operation on the  
 6 Reverse Common Control Channel, configure the mobile station simulator to  
 7 send a Reservation Access Enhanced Access Probe with the Enhanced Access  
 8 Channel Header parameter RATE\_WORD set to “2” (19200 bps, 10 ms frame)  
 9 and perform steps 12 through 16.
- 10 10. If the base station supports 38400 bps, 10 ms frame size operation on the  
 11 Reverse Common Control Channel, configure the mobile station simulator to  
 12 send a Reservation Access Enhanced Access Probe with the Enhanced Access  
 13 Channel Header parameter RATE\_WORD set to “4” (38400 bps, 10 ms frame)  
 14 and perform steps 12 through 16.
- 15 11. If the base station supports 38400 bps, 5 ms frame size operation on the  
 16 Reverse Common Control Channel, configure the mobile station simulator to  
 17 send a Reservation Access Enhanced Access Probe with the Enhanced Access  
 18 Channel Header parameter RATE\_WORD set to “5” (38400 bps, 5 ms frame)  
 19 and perform steps 12 through 16.
- 20 12. Once the end of the Enhanced Access Channel Header is detected, send an  
 21 *Early Acknowledgement Channel Assignment Message* on the Common  
 22 Assignment Channel addressed to the mobile station simulator.
- 23 13. Transmit the Reverse Common Control Channel at the level specified in step  
 24 3 to ensure the  $E_b/N_0$  at each RF input port is within the specified limits.
- 25 14. Send pseudo-random test data to the base station.
- 26 15. Measure the frame error rate as described in 6.7.
- 27 16. Repeat steps 12-15 until the required test confidence level is met.

### 28 3.3.2.3 Minimum Standard

29 With 95% confidence (see 6.8), the FER for each data rate shall not exceed that given  
 30 by linear interpolation on a  $\log_{10}$  scale between the two values given in Table A.2.2-1  
 31 at the average of the two  $E_b/N_0$  values measured in dB at the two RF input ports. The  
 32 interpolated value,  $FER_{lim}$ , is given by

$$\begin{aligned}
 &\log_{10}(FER_{lim}) = \log_{10}(FER_{upper}) \\
 &+ \left( \frac{(E_b/N_0)_{upper} - (E_b/N_0)_{meas}}{(E_b/N_0)_{upper} - (E_b/N_0)_{lower}} \right) \times [\log_{10}(FER_{lower}) - \log_{10}(FER_{upper})]
 \end{aligned}$$

34 where the subscripts “upper” and “lower” refer to entries in Table A.2.2-1.  
 35  $(E_b/N_0)_{meas}$  is the measured value in dB.

### 3.4 Reverse Channel Quality Indicator Channel Demodulation Performance

The tests in this section verify the demodulation performance of Reverse Channel Quality Indicator Channel under AWGN and fading conditions. For base stations that support full C/I reporting mode, the full C/I value decoding performance is verified using full C/I reporting mode. For base stations that do not support full C/I reporting mode, the full C/I value decoding performance is verified using differential C/I reporting mode. For base stations that do not support differential C/I reporting mode, the differential C/I value decoding performance is not verified.

#### 3.4.1 Performance in Additive White Gaussian Noise

##### 3.4.1.1 Definition

The demodulation performance of the Reverse Channel Quality Indicator Channel in an AWGN (no fading or multipath) environment is determined by the frame error rate (FER) at specified values of  $E_b/N_0$ . Closed loop reverse link power control is not used in these tests.

##### 3.4.1.2 Method of Measurement

Refer to Figure 6.5.1-1 for a functional block diagram of the test setup. Perform the following steps:

1. Configure the base station under test and a mobile station simulator as shown in Figure 6.5.1-1<sup>5</sup>.
2. Adjust the AWGN generators to yield a noise power spectral density of -84 dBm/1.23 MHz  $\pm$ 5 dB at each base station receiver input.
3. For each band class that the base station supports, configure the base station to operate in that band class and perform steps 4 through 11.
4. Adjust the equipment so that the Reverse Channel Quality Indicator Channel  $E_b/N_0$  at each RF input port is within the range specified in Table A.3.1-1. Closed loop power control in the mobile station simulator shall be disabled (see 6.4.3).
5. If the base station supports demodulation of the Reverse Channel Quality Indicator Channel with full reporting mode, perform steps 6 through 7.
6. Set up a call using the Channel Quality Indicator Channel Test Mode (see 1.3). Configure the mobile station simulator to use full reporting mode and no repetition on the Reverse Channel Quality Indicator Channel. Transmit the data pattern specified in [6] from the mobile station simulator on the Reverse Channel Quality Indicator Channel.

---

<sup>5</sup> For Femto Cells with one input port, only one of the two Rx inputs into the Base Station under test in the figure shall be used.

- 1 7. Measure the Reverse Channel Quality Indicator Channel frame error rate as  
2 described in 6.7, for the 3200 bits/s data rate.
- 3 8. If the base station supports demodulation of the Reverse Channel Quality  
4 Indicator Channel with differential reporting mode, perform steps 9 through  
5 11.
- 6 9. Set up a call using the Channel Quality Indicator Channel Test Mode (see  
7 1.3). Configure the mobile station simulator to use differential reporting  
8 mode and no repetition on the Reverse Channel Quality Indicator Channel.  
9 Transmit the data pattern specified in [6] from the mobile station simulator  
10 on the Reverse Channel Quality Indicator Channel.
- 11 10. Measure the Reverse Channel Quality Indicator Channel frame error rate as  
12 described in 6.7, for the 800 bits/s data rate frames.
- 13 11. If the base station does not support demodulation of the Reverse Channel  
14 Quality Indicator Channel with full reporting mode, then also measure the  
15 Reverse Channel Quality Indicator Channel frame error rate as described in  
16 6.7, for the 3200 bits/s data rate frames.

#### 17 3.4.1.3 Minimum Standard

18 With 95% confidence (see 6.8), the FER shall not exceed that given by linear  
19 interpolation on a  $\log_{10}$  scale between the two values given in Table A.3.1-1 at the  
20 larger of the  $E_b/N_0$  values at the two RF input ports, or at  $E_b/N_0$  at the RF input port  
21 in the case of Femto Cells with single RF input ports. The interpolated value,  $FER_{lim}$ ,  
22 is given by

$$23 \log_{10}(FER_{lim}) = \log_{10}(FER_{upper})$$

$$24 + \left( \frac{(E_b/N_0)_{upper} - (E_b/N_0)_{meas}}{(E_b/N_0)_{upper} - (E_b/N_0)_{lower}} \right) \times [\log_{10}(FER_{lower}) - \log_{10}(FER_{upper})]$$

24 where the subscripts 'upper' and 'lower' refer to  $E_b/N_0$  limits and FER entries in  
25 Table A.3.1-1.  $(E_b/N_0)_{meas}$  is the measured value in dB.

#### 26 3.4.2 Performance in Multipath Fading with Closed Loop Power Control

##### 27 3.4.2.1 Definition

28 The performance of the demodulation of Reverse Channel Quality Indicator Channel  
29 with closed loop power control in a multipath fading environment is determined by  
30 the frame error rate (FER) at specified values of  $E_b/N_0$ . Refer to 6.7 for the definition  
31 of FER. For Femto Cells with one RF input port, these tests are not specified..

##### 32 3.4.2.2 Method of Measurement

33 Refer to Figure 6.5.1-2 for a functional block diagram of the test setup. Perform the  
34 following steps:

- 35 1. Configure both the base station under test and a mobile station simulator as  
36 shown in Figure 6.5.1-2.

- 1        2. Adjust the AWGN generators to yield a noise power spectral density of -84
- 2                dBm/1.23 MHz  $\pm$  5 dB at each base station receiver input.
- 3        3. For each band class that the base station supports, configure the base
- 4                station to operate in that band class and perform steps 4 through 11.
- 5        4. For each case in Table A.3.2-1, adjust the equipment so that the mean
- 6                Reverse Channel Quality Indicator Channel  $E_b/N_0$  at each RF input port is
- 7                within the range specified in Table A.3.2-1. Closed loop power control in the
- 8                mobile station simulator shall be enabled (see 6.4.3). The power control outer
- 9                loop in the base station shall be disabled. The channel simulator
- 10                configurations (see 6.4.1) for each case are as follows:

11

<b>Case</b>	<b>Channel Simulator Configuration</b>
A	1 (3 km/h, 1 path)
B	2 (8 km/h, 2 paths)
C	3 (30 km/h, 1 path)
D	4 (100 km/h, 3 path)

12

Tests using Case D are not required for Pico Cell base stations. Tests for Femto Cells with two antennas are limited to only Cases A and C.

13

- 14        5. If the base station supports demodulation of the Reverse Channel Quality
- 15                Indicator Channel with full reporting mode, perform steps 6 through 7.
- 16        6. Set up a call using the Channel Quality Indicator Channel Test Mode (see
- 17                1.3). Configure the mobile station simulator to use full reporting mode and
- 18                no repetition on the Reverse Channel Quality Indicator Channel. Transmit
- 19                the data pattern specified in [6] from the mobile station simulator on the
- 20                Reverse Channel Quality Indicator Channel.
- 21        7. Measure the Reverse Channel Quality Indicator Channel frame error rate as
- 22                described in 6.7, for the 3200 bits/s data rate.
- 23        8. If the base station supports demodulation of the Reverse Channel Quality
- 24                Indicator Channel with differential reporting mode, perform steps 9 through
- 25                11.
- 26        9. Set up a call using the Channel Quality Indicator Channel Test Mode (see
- 27                1.3). Configure the mobile station simulator to use differential reporting
- 28                mode and no repetition on the Reverse Channel Quality Indicator Channel.
- 29                Transmit the data pattern specified in [6] from the mobile station simulator
- 30                on the Reverse Channel Quality Indicator Channel.
- 31        10. Measure the Reverse Channel Quality Indicator Channel frame error rate as
- 32                described in 6.7, for the 800 bits/s data rate frames.

- 1 11. If the base station does not support demodulation of the Reverse Channel  
 2 Quality Indicator Channel with full reporting mode, then also measure the  
 3 Reverse Channel Quality Indicator Channel frame error rate as described in  
 4 6.7, for the 3200 bits/s data rate frames.

#### 5 3.4.2.3 Minimum Standard

6 With 95% confidence (see 6.8), the FER shall not exceed that given by linear  
 7 interpolation on a  $\log_{10}$  scale between the two values given in Tables A.3.2-1 at the  
 8 average of the two  $E_b/N_0$  values measured in dB at the two RF input ports. The  
 9 interpolated value,  $FER_{lim}$ , is given by

$$10 \log_{10}(FER_{lim}) = \log_{10}(FER_{upper}) + \left( \frac{(E_b/N_0)_{upper} - (E_b/N_0)_{meas}}{(E_b/N_0)_{upper} - (E_b/N_0)_{lower}} \right) \times [\log_{10}(FER_{lower}) - \log_{10}(FER_{upper})]$$

11 where the subscripts “upper” and “lower” refer to entries in Tables A.4.2-1.  
 12  $(E_b/N_0)_{meas}$  is the measured value in dB.

### 13 3.5 Reverse Acknowledgment Channel Demodulation Performance

14 The tests in this section verify the demodulation performance of the Reverse  
 15 Acknowledgment Channel under AWGN and fading conditions. Note that the number  
 16 of decoding states for the Reverse Acknowledgment Channel is implementation  
 17 dependent. A base station may, for example, decode three values (ACK, NAK, or  
 18 DTX). The tests described in this section assume only two decoding states (ACK or  
 19 NAK). If the number of implemented decoding states in the base station is more than  
 20 two, then the use of an appropriate mapping into the two allowed states is performed.

#### 21 3.5.1 Performance in Additive White Gaussian Noise

##### 22 3.5.1.1 Definition

23 The demodulation performance of the Reverse Acknowledgment Channel in an AWGN  
 24 (no fading or multipath) environment is determined by the false alarm (i.e. decoding  
 25 an ACK value while either NAK or nothing was transmitted) and missed detection (i.e.  
 26 decoding a NAK value while ACK was transmitted) error rates at a specified value of  
 27  $E_b/N_0$ . Refer to 6.7 for the definition of the false alarm rate (FAR) and missed  
 28 detection rate (MDR). Closed loop reverse link power control is not used in these  
 29 tests.

##### 30 3.5.1.2 Method of Measurement

31 Refer to Figure 6.5.1-1 for a functional block diagram of the test setup. Perform the  
 32 following steps:

- 1        1.    Configure the base station under test and a mobile station simulator as  
2            shown in Figure 6.5.1-1<sup>6</sup>.
- 3        2.    Adjust the AWGN generators to yield a noise power spectral density of -84  
4            dBm/1.23 MHz ±5 dB at each base station receiver input.
- 5        3.    Configure the base station to use a single Forward Packet Data Control  
6            Channel.
- 7        4.    For each band class that the base station supports, configure the base  
8            station to operate in that band class and perform steps 5 through 7.
- 9        5.    Adjust the equipment so that the Reverse Acknowledgment Channel  $E_b/N_0$   
10           (for active frames) at each RF input port is 10.3 dB ±0.2 dB for units with 2  
11           RF input ports, and 14.8 dB ±0.2 dB for Femto Cells with 1 RF input port.  
12           Closed loop power control in the mobile station simulator shall be disabled  
13           (see 6.4.3).
- 14       6.    Set up a call using Reverse Acknowledgment Channel Test Mode (see 1.3).  
15           Configure the mobile station simulator to use no repetition on the Reverse  
16           Acknowledgment Channel (REV\_ACKCH\_REPS = '00'). Configure the base  
17           station to transmit on the Forward Packet Data Control Channel one slot  
18           length messages addressed to the mobile station simulator with a duty cycle  
19           equal to 100%.
- 20       7.    Measure the Reverse Acknowledgment Channel false alarm and missed  
21           detection rates as described in 6.7.

### 22    3.5.1.3 Minimum Standard

23    With 95% confidence, the point with coordinates ( $FAR_{meas}$ ,  $MDR_{meas}$ ) shall not  
24    exceed the piecewise linear curve specified by the points in Table A.4.1-1. When  
25    determining the piecewise linear curve, a linear interpolation on a  $\log_{10}$  scale is used,  
26    where the  $MDR_{int}$  coordinate of interpolated point ( $FAR_{int}$ ,  $MDR_{int}$ ) is given by

$$27 \quad \log_{10}(MDR_{int}) = \log_{10}(MDR_{lower}) + \left( \frac{\log_{10}(FAR_{int}) - \log_{10}(FAR_{lower})}{\log_{10}(FAR_{upper}) - \log_{10}(FAR_{lower})} \right) \times [\log_{10}(MDR_{upper}) - \log_{10}(MDR_{lower})]$$

28    where the subscripts 'upper' and 'lower' refer to two consecutive FAR values and the  
29    corresponding MDR entries in Table A.4.1-1.

30    The required 95% confidence is achieved if  $FAR_{meas}$  is less than  $FAR_x$  with at least  
31    95% confidence (see 6.8), and  $MDR_{meas}$  is less than  $MDR_x$  with at least 95%  
32    confidence, where ( $FAR_x$ ,  $MDR_x$ ) are the coordinates of the point on the piecewise

---

<sup>6</sup> For Femto Cells with one input port, only one of the two Rx inputs into the Base Station under test in the figure shall be used.

1 linear curve that is closest to point  $(FAR_{meas}, MDR_{meas})$ . Closest is meant in the  
 2 sense that the value  $D_{meas, x}$  is minimized, where  
 3

$$D_{meas, x} = (\log_{10}(FAR_{meas}) - \log_{10}(FAR_x))^2 + (\log_{10}(MDR_{meas}) - \log_{10}(MDR_x))^2$$

### 5 3.5.2 Performance in Multipath Fading with Closed Loop Power Control

#### 6 3.5.2.1 Definition

7 The performance of the demodulation of Reverse Acknowledgment Channel with  
 8 closed loop power control in a multipath fading environment is determined by the  
 9 false alarm (i.e. decoding an ACK value while either NAK or nothing was transmitted)  
 10 and missed detection (i.e. decoding a NAK value while ACK was transmitted) error  
 11 rates at a specified value of average  $E_b/N_0$ . Refer to 6.7 for the definition of the false  
 12 alarm rate (FAR) and missed detection rate (MDR). For Femto Cells with one RF input  
 13 port, these tests are not specified.

#### 14 3.5.2.2 Method of Measurement

15 Refer to Figure 6.5.1-2 for a functional block diagram of the test setup. Perform the  
 16 following steps:

- 17 1. Configure both the base station under test and a mobile station simulator as  
 18 shown in Figure 6.5.1-2.
- 19 2. Adjust the AWGN generators to yield a noise power spectral density of -84  
 20 dBm/1.23 MHz  $\pm$  5 dB at each base station receiver input.
- 21 3. Configure the base station to use a single Forward Packet Data Control  
 22 Channel.
- 23 4. For each band class that the base station supports, configure the base  
 24 station to operate in that band class and perform steps 5 through 7.
- 25 5. For each case in Table A.4.2-1, adjust the equipment so that the mean  
 26 Reverse Acknowledgment Channel  $E_b/N_0$  at each RF input port is within  
 27  $\pm 0.2$ dB of the value shown below. (See 6.4.1 for a description of the channel  
 28 simulator configurations.) Closed loop power control in the mobile station  
 29 simulator shall be enabled (see 6.4.3). The reverse link power control outer  
 30 loop in the base station shall be disabled.

31

Case	Channel Simulator Configuration	R-ACKCH $E_b/N_0$ (dB)
A	1 (3 km/h, 1 path)	(1): 11.2 (2): 11.2 (3): 11.2
B	2 (8 km/h, 2 paths)	(1): 11.7 (2): 11.6 (3): 12.1
C	3 (30 km/h, 1 path)	(1): 11.9 (2): 12.3 (3): 13.1
D	4 (100 km/h, 3 path)	(1): 12.3 (2): 12.9 (3): 13.4

(1): BC 5 and 11; (2): BC 0, 2, 3, 7, 9, 10 and 12; (3): BC 1, 4, 6 and 8

- 1 Tests using Case D are not required for Pico Cell base stations. Tests for  
2 Femto Cells with two antennas are limited to only Cases A and C.
- 3 6. Set up a call using Reverse Acknowledgment Channel Test Mode 1 (see 1.3).  
4 Configure the mobile station simulator to use no repetition on the Reverse  
5 Acknowledgment Channel. Configure the base station to transmit on the  
6 Forward Packet Data Control Channel one slot length messages addressed to  
7 the mobile station simulator with a duty cycle equal to 100%.
- 8 7. Measure the Reverse Acknowledgment Channel false alarm and missed  
9 detection rates as described in 6.7.

### 10 3.5.2.3 Minimum Standard

#### 11 Test 1:

12 With 95% confidence, the point with coordinates ( $FAR_{meas}$ ,  $MDR_{meas}$ ) shall not  
13 exceed the piecewise linear curve specified by the points in Table A.4.2-1. When  
14 determining the piecewise linear curve, a linear interpolation on a  $\log_{10}$  scale is used,  
15 where the  $MDR_{int}$  coordinate of interpolated point ( $FAR_{int}$ ,  $MDR_{int}$ ) is given by

$$16 \log_{10}(MDR_{int}) = \log_{10}(MDR_{lower}) + \left( \frac{\log_{10}(FAR_{int}) - \log_{10}(FAR_{lower})}{\log_{10}(FAR_{upper}) - \log_{10}(FAR_{lower})} \right) \times [\log_{10}(MDR_{upper}) - \log_{10}(MDR_{lower})]$$

17 where the subscripts 'upper' and 'lower' refer to consecutive FAR values and the  
18 corresponding MDR entries in Table A.4.2-1.

19 The required 95% confidence is achieved if  $FAR_{meas}$  is less than  $FAR_x$  with at least  
20 95% confidence (see 6.8), and  $MDR_{meas}$  is less than  $MDR_x$  with at least 95%

confidence, where  $(FAR_x, MDR_x)$  are the coordinates of the point on the piecewise linear curve that is closest to point  $(FAR_{meas}, MDR_{meas})$ . Closest is meant in the sense that the value  $D_{meas,x}$  is minimized, where

$$D_{meas,x} = (\log_{10}(FAR_{meas}) - \log_{10}(FAR_x))^2 + (\log_{10}(MDR_{meas}) - \log_{10}(MDR_x))^2$$

### 3.6 Reverse Traffic Channel Demodulation Performance

The tests in this section verify the demodulation performance of Reverse Traffic Channel under AWGN and fading conditions.

#### 3.6.1 Performance in Additive White Gaussian Noise

##### 3.6.1.1 Definition

The demodulation performance of the Reverse Traffic Channel in an AWGN (no fading or multipath) environment is determined by the frame error rate (FER) at specified values of  $E_b/N_0$ .

##### 3.6.1.2 Method of Measurement

Refer to Figure 6.5.1-1 for a functional block diagram of the test setup. For each Radio Configuration supported on Reverse Fundamental Channel, Reverse Dedicated Control Channel, Reverse Supplemental Code Channel, or Reverse Supplemental Channel perform the following steps:

1. Configure the base station under test and a mobile station simulator as shown in Figure 6.5.1-1.
2. Adjust the AWGN generators to yield a noise power spectral density of -84 dBm/1.23 MHz  $\pm$ 5 dB at each base station receiver input.
3. For each band class that the base station supports, configure the base station to operate in that band class and perform steps 4 through 12.
4. For each radio configuration that the base station is capable of demodulating, perform steps 5 through 12.
5. If the base station supports convolutional coding of the radio configuration under test, perform steps 7 through 12 using convolutional coding.
6. If the base station supports turbo coding of the radio configuration under test, perform steps 7 through 12 using turbo coding.
7. Adjust the equipment so that the Reverse Traffic Channel  $E_b/N_0$  for the channel under test (along with the Reverse Pilot Channel and Reverse Power Control Subchannel if applicable) at each RF input port is within the range specified in Tables A.5.1-1 through A.5.1-8. Reverse Traffic Channel closed loop power control in the mobile station simulator shall be disabled (see 6.4.3).

- 1       8. If the base station supports demodulation of the Reverse Fundamental  
2       Channel for the radio configuration under test, set up a call using the  
3       appropriate Fundamental Channel test mode (see 1.3) with frame activity  
4       equal to 100%. Transmit random data from the mobile station simulator at  
5       each of the specified data rates. This may be done either as separate single  
6       rate tests or as one mixed rate test.
- 7       9. If the base station supports demodulation of the Reverse Fundamental  
8       Channel and the Reverse Fundamental Channel gating for the radio  
9       configuration under test, set up a call using the appropriate Fundamental  
10      Channel test mode (see 1.3) with frame activity equal to 100%. Set up the  
11      base station under test and the mobile station simulator to activate the  
12      Reverse Fundamental Channel gating. Transmit random data from the mobile  
13      station simulator at the 1500 bps or 1800 bps data rate that is applicable to  
14      the reverse radio configuration under test.
- 15     10. If the base station does not support demodulation of the Reverse  
16     Fundamental Channel for the radio configuration under test, setup a call  
17     using the appropriate Dedicated Control Channel test mode (see 1.3) with  
18     frame activity equal to 100%. Transmit random data from the mobile station  
19     simulator.
- 20     11. If the base station supports demodulation of the Reverse Supplemental  
21     Channel or Reverse Supplemental Code Channel for the radio configuration  
22     under test, setup a call using the appropriate Supplemental Channel test  
23     mode or Supplemental Code Channel test mode (see 1.3) with frame activity  
24     equal to 100%. For each supported data rate, transmit random data at a fixed  
25     rate from the mobile station simulator.
- 26     12. For each supported data rate, measure the frame error rate as described in  
27     6.7.

### 28   3.6.1.3 Minimum Standard

29   With 95% confidence (see 6.8), the FER for each data rate shall not exceed that given  
30   by linear interpolation on a  $\log_{10}$  scale between the two values given in Tables A.5.1-1  
31   through A.5.1-8 at the larger of the  $E_b/N_0$  values at the two RF input ports, or at  
32    $E_b/N_0$  at the RF input port in the case of Femto Cells with single RF input ports. The  
33   interpolated value,  $FER_{lim}$ , is given by

$$34 \quad \log(FER_{lim}) = \log(FER_{upper}) + \left( \frac{(E_b/N_0)_{upper} - (E_b/N_0)_{meas}}{(E_b/N_0)_{upper} - (E_b/N_0)_{lower}} \right) \times [\log(FER_{lower}) - \log(FER_{upper})]$$

35   where the subscripts 'upper' and 'lower' refer to  $E_b/N_0$  limits and FER entries in  
36   Tables A.5.1-1 through A.5.1-8.  $(E_b/N_0)_{meas}$  is the measured value in dB.

### 3.6.2 Performance in Multipath Fading without Closed Loop Power Control

This test is performed for Radio Configurations 1 and 2 only. For Femto Cells with one RF input port, these tests are not specified.

**3.6.2.1 Definition**  
The performance of the demodulation of the Reverse Traffic Channel in a multipath fading environment is determined by the frame error rate (FER) at specified values of  $E_b/N_0$ .

The FER is calculated for four data rates if the Reverse Fundamental Channel is supported by the base station. Otherwise, the FER is calculated for one data rate. This test is also performed for the Reverse Supplemental Code Channel if it is supported by the base station. Refer to 6.7 for the definition of FER.

#### 3.6.2.2 Method of Measurement

Refer to Figure 6.5.1-2 for a functional block diagram of the test setup. Reverse Traffic Channel closed loop power control in the base station shall be disabled during this test.

1. Configure both the base station under test and a mobile station simulator as shown in Figure 6.5.1-2.
2. Adjust the AWGN generators to yield a noise power spectral density of -84 dBm/1.23 MHz  $\pm$ 5 dB at each base station receiver input.
3. For each band class that the base station supports, configure the base station to operate in that band class and perform steps 4 through 9.
4. For each radio configuration that the base station is capable of demodulating, perform steps 5 through 9.
5. For each case in Table A.5.2-1 specified for the radio configuration under test except Case D2, adjust the equipment so that the mean Reverse Traffic Channel  $E_b/N_0$  at each RF input port is within the range specified in Table A.5.2-1. Reverse Traffic Channel closed loop power control in the mobile station simulator shall be disabled (see 6.4.3). The channel simulator configurations (see 6.4.1) for each case are as follows:

Case	Channel Simulator Configuration
B	2 (8 km/h, 2 paths)
C	3 (30 km/h, 1 path)
D	4 (100 km/h, 3 path)
D2	4 (100 km/h, 3 path)

Tests using Case D or D2 are not required for Pico Cell base stations.

Tests for Femto Cells with two antennas are limited to only Case C.

- 1       6. Set up a call using the appropriate Fundamental Channel test mode (see 1.3)
- 2       with frame activity equal to 100%.
- 3       7. Transmit random data to the mobile station simulator at each of the four data
- 4       rates. This may be done either as separate single rate tests or as one mixed
- 5       rate test.
- 6       8. For each of the four data rates, measure the frame error rate as described in
- 7       6.7.
- 8       9. If case D results in an FER of greater than 0.5%, repeat steps 5 through 9 for
- 9       case D2.

### 10   3.6.2.3 Minimum Standard

11   With 95% confidence (see 6.8), the FER for each data rate shall not exceed that given  
 12   by linear interpolation on a  $\log_{10}$  scale between the two values given in Tables A.5.2-1  
 13   and A.5.2-2 at the average of the two  $E_b/N_0$  values measured in dB at the two RF  
 14   input ports. The interpolated value,  $FER_{lim}$ , is given by

$$\begin{aligned}
 &\log_{10}(FER_{lim}) = \log_{10}(FER_{upper}) \\
 &+ \left( \frac{(E_b/N_0)_{upper} - (E_b/N_0)_{meas}}{(E_b/N_0)_{upper} - (E_b/N_0)_{lower}} \right) \times [\log_{10}(FER_{lower}) - \log_{10}(FER_{upper})]
 \end{aligned}$$

16   where the subscripts 'upper' and 'lower' refer to  $E_b/N_0$  limits described in Table  
 17   A.5.2-1 and FER entries in Tables A.5.2-2 and A.5.2-3.  $(E_b/N_0)_{meas}$  is the measured  
 18   value in dB.

### 19   3.6.3 Performance in Multipath Fading with Closed Loop Power Control

#### 20   3.6.3.1 Definition

21   The performance of the demodulation of Reverse Traffic Channel with closed loop  
 22   power control in a multipath fading environment is determined by the frame error  
 23   rate (FER) at specified values of  $E_b/N_0$ . Refer to 6.7 for the definition of FER. For  
 24   Femto Cells with one RF input port, these tests are not specified..

#### 25   3.6.3.2 Method of Measurement

26   Refer to Figure 6.5.1-2 for a functional block diagram of the test setup. For each  
 27   Radio Configuration supported on Reverse Fundamental Channel, Reverse Dedicated  
 28   Control Channel, Reverse Supplemental Code Channel, or Reverse Supplemental  
 29   Channel perform the following steps:

- 30       1. Configure both the base station under test and a mobile station simulator as
- 31       shown in Figure 6.5.1-2.
- 32       2. Adjust the AWGN generators to yield a noise power spectral density of -84
- 33       dBm/1.23 MHz  $\pm$  5 dB at each base station receiver input.
- 34       3. For each band class that the base station supports, configure the base
- 35       station to operate in that band class and perform steps 4 through 12.

- 1 4. For each radio configuration that the base station is capable of demodulating,  
2 perform steps 5 through 12.
- 3 5. If the base station supports convolutional coding of the radio configuration  
4 under test, perform steps 7 through 12 using convolutional coding.
- 5 6. If the base station supports turbo coding of the radio configuration under  
6 test, perform steps 7 through 12 using turbo coding.
- 7 7. For each case in Tables A.5.3-1 through A.5.3-10 specified for the radio  
8 configuration under test, adjust the equipment so that the mean Reverse  
9 Traffic Channel  $E_b/N_0$  for the channel under test (along with the Reverse  
10 Pilot Channel and Reverse Power Control Subchannel if applicable) at each  
11 RF input port is within the range specified in Tables A.5.3-1 through A.5.3-  
12 10. Reverse Traffic Channel closed loop power control in the mobile station  
13 simulator shall be enabled (see 6.4.3). The channel simulator configurations  
14 (see 6.4.1) for each case are as follows:

15

<b>Case</b>	<b>Channel Simulator Configuration</b>
A	1 (3 km/h, 1 path)
B	2 (8 km/h, 2 paths)
C	3 (30 km/h, 1 path)
D	4 (100 km/h, 3 path)

16 Tests using Case D are not required for Pico Cell base stations. Tests for  
17 Femto Cells with two antennas are limited to only Cases A and C.

- 18 8. If the base station supports demodulation of the Reverse Fundamental  
19 Channel for the radio configuration under test, set up a call using the  
20 appropriate Fundamental Channel test mode (see 1.3) with frame activity  
21 equal to 100%. Transmit random data to the mobile station simulator at each  
22 of the specified data rates. This may be done either as separate single rate  
23 tests or as one mixed rate test.
- 24 9. If the base station does not support demodulation of the Reverse  
25 Fundamental Channel for the radio configuration under test, setup a call  
26 using the appropriate Dedicated Control Channel test mode (see 1.3) with  
27 frame activity equal to 100% and a 20 ms frame length. Transmit random  
28 data to the mobile station simulator.
- 29 10. If the base station supports demodulation of the Reverse Dedicated Control  
30 Channel for the radio configuration under test, setup a call using the  
31 appropriate Dedicated Control Channel test mode (see 1.3) with frame activity  
32 equal to 10% and a 20 ms frame length. Transmit random data to the mobile  
33 station simulator.

- 1 11. If the base station supports demodulation of the Reverse Supplemental  
 2 Channel or Reverse Supplemental Code Channel for the radio configuration  
 3 under test, setup a call using the appropriate Supplemental Channel test  
 4 mode or Supplemental Code Channel test mode (see 1.3) with frame activity  
 5 equal to 100%. For each supported data rate, transmit random data at a fixed  
 6 rate to the mobile station simulator.
- 7 12. For each supported data rate, measure the frame error rate as described in  
 8 6.7.

### 9 3.6.3.3 Minimum Standard

10 With 95% confidence (see 6.8), the FER for each data rate shall not exceed that given  
 11 by linear interpolation on a  $\log_{10}$  scale between the two values given in Tables A.5.3-1  
 12 through A.5.3-10 at the average of the two  $E_b/N_0$  values measured in dB at the two  
 13 RF input ports. The interpolated value,  $FER_{lim}$ , is given by

$$\log_{10}(FER_{lim}) = \log_{10}(FER_{upper}) + \left( \frac{(E_b/N_0)_{upper} - (E_b/N_0)_{meas}}{(E_b/N_0)_{upper} - (E_b/N_0)_{lower}} \right) \times [\log_{10}(FER_{lower}) - \log_{10}(FER_{upper})]$$

15 where the subscripts “upper” and “lower” refer to entries in Tables A.5.3-1 through  
 16 A.5.3-10.  $(E_b/N_0)_{meas}$  is the measured value in dB.

## 17 3.7 Receiver Performance

### 18 3.7.1 Receiver Sensitivity

#### 19 3.7.1.1 Definition

20 The receiver sensitivity of the base station receiver is defined as the minimum  
 21 received power, measured at the base station RF input ports, at which the Reverse  
 22 Traffic Channel FER is maintained at 1%.

#### 23 3.7.1.2 Method of Measurement

24 Refer to Figure 6.5.1-1 for a functional block diagram of the test setup.

- 25 1. Configure the base station under test and a mobile station simulator as  
 26 shown in Figure 6.5.1-1<sup>7</sup>.
- 27 2. Disable the AWGN generators (set their output powers to zero).
- 28 3. For each band class that the base station supports, configure the base  
 29 station to operate in that band class and perform steps 4 through 8.

---

<sup>7</sup> For Femto Cells with one input port, only one of the two Rx inputs into the Base Station under test in the figure shall be used.

- 1 4. If the base station supports demodulation of Radio Configuration 1, 2, 3, or 4,  
 2 set up a call using Fundamental Traffic Channel Test Mode 1 or 3 (see 1.3) or  
 3 Dedicated Control Channel Test Mode 3 (see 1.3) and perform steps 6  
 4 through 8.
- 5 5. If the base station supports demodulation of Radio Configuration 5 or 6, set  
 6 up a call using Fundamental Channel Test Mode 7 or Dedicated Control  
 7 Channel Test Mode 7 (see 1.3) and perform steps 6 through 8.
- 8 6. Adjust the equipment to ensure that a signal power of the value as specified  
 9 in Table 3.7.1.2-1 per RF input port is not exceeded. Reverse Traffic Channel  
 10 closed loop power control in the mobile station simulator should be disabled  
 11 (see 6.4.3).
- 12 7. Transmit random data to the mobile station simulator at full data rate.
- 13 8. Measure the frame error rate as described in 6.7.

14 **Table 3.7.1.2-1: Base Station Sensitivity**

<b>BS class</b>	<b>Sensitivity</b>
Macro Cell BS	-117dBm for Band Groups 450 and 800 or -119 dBm for Band Group 1900
Pico Cell BS	-117dBm
Femto Cell	-110 dBm

15

16 3.7.1.3 Minimum Standard

17 The FER shall be 1.0% or less with 95% confidence (see 6.8).

18 3.7.2 Receiver Dynamic Range

19 3.7.2.1 Definition

20 The receiver dynamic range is the input power range at the base station RF input  
 21 ports over which the FER does not exceed a specific value. Its lower limit is the  
 22 sensitivity as measured by the test in 3.7.1. Its upper limit is the maximum total  
 23 power per RF input port at which an FER of 1% is maintained.

24 3.7.2.2 Method of Measurement

25 Refer to Figure 6.5.1-1 for a functional block diagram of the test setup.

1. Configure the base station under test and a mobile station simulator as shown in Figure 6.5.1-1<sup>8</sup>.
- For each band class that the base station supports, configure the base station to operate in that band class and perform steps 3 through 8.
- If the base station supports demodulation of Radio Configuration 1 or 2, set up a call using Fundamental Channel Test Mode 1 (see 1.3) and perform steps 6 through 8.
- If the base station supports demodulation of Radio Configuration 3 or 4, set up a call using Fundamental Channel Test Mode 3 or Dedicated Control Channel Test Mode 3 (see 1.3) and perform steps 6 through 8.
- If the base station supports demodulation of Radio Configuration 5 or 6, set up a call using Fundamental Channel Test Mode 7 or Dedicated Control Channel Test Mode 7 (see 1.3) and perform steps 6 through 8.
- Adjust the equipment for a noise power spectral density at each RF input port of not less than the value as specified in Table 3.7.2.2-1 and a signal power corresponding to an  $E_b/N_0$  of 10 dB  $\pm$  1 dB. Reverse Traffic Channel closed loop power control in the mobile station simulator may be disabled (see 6.4.3).
- Transmit random data to the mobile station simulator at full data rate.
- Measure the frame error rate as described in 6.7.

**Table 3.7.2.2-1: Base Station Dynamic Range**

<b>BS class</b>	<b>Power spectral density</b>
Macro Cell BS	- 65 dBm/1.23MHz
Pico Cell BS and Femto Cell	-39 dBm/1.23MHz

22

### 3.7.2.3 Minimum Standard

The FER shall be 1.0% or less with 95% confidence (see 6.8).

### 3.7.3 Single Tone Desensitization

#### 3.7.3.1 Definition

Single tone desensitization is a measure of the ability to receive a CDMA signal on the assigned channel frequency in the presence of a single tone that is offset from the center frequency of the assigned channel.

---

<sup>8</sup> For Femto Cells with one input port, only one of the two Rx inputs into the Base Station under test in the figure shall be used.

1 For licensed bandwidths where CDMA is not the only expected technology, a high  
 2 power CW tone level requirement simulates a non-CDMA narrow-band interferer. For  
 3 licensed bandwidths where CDMA is the only expected technology<sup>9</sup>, a lower power CW  
 4 tone level requirement simulates an interfering CDMA mobile station being power-  
 5 controlled by a non-collocated CDMA base station.

### 6 3.7.3.2 Method of Measurement

7 Refer to Figure 6.5.1-3 for a functional block diagram of the test setup.

- 8 1. Configure the base station under test and a mobile station simulator as  
 9 shown in Figure 6.5.1-3<sup>10</sup>.
- 10 2. For each band class that the base station supports, configure the base  
 11 station to operate in that band class and perform steps 3 through 9.
- 12 3. Adjust the equipment to ensure path losses of at least 100 dB. All power  
 13 control mechanisms shall be enabled and set at nominal values.
- 14 4. If the base station supports demodulation of Radio Configuration 1 or 2, set  
 15 up a call using Fundamental Channel Test Mode 1 (see 1.3) and perform  
 16 steps 7 through 9.
- 17 5. If the base station supports demodulation of Radio Configuration 3 or 4, set  
 18 up a call using Fundamental Channel Test Mode 3 or Dedicated Control  
 19 Channel Test Mode 3 (see 1.3) and perform steps 7 through 9.
- 20 6. If the base station supports demodulation of Radio Configuration 5 or 6, set  
 21 up a call using Fundamental Channel Test Mode 7 or Dedicated Control  
 22 Channel Test Mode 7 (see 1.3) and perform steps 7 through 9.
- 23 7. Transmit random data to the mobile station simulator at full data rate.
- 24 8. Measure the mobile station simulator output power at the RF input ports.
- 25 9. Perform steps 10 through 12 with the bandwidth of the receiver pass band  
 26 used in steps 10 and 11 defined equal to  $n \times 1.23$  MHz (Band Class 0),  $n \times$   
 27  $1.24$  MHz (Band Subclasses 5, 6, or 7 of Band Class 5), or  $n \times 1.25$  MHz (all  
 28 other band classes and subclasses), where  $n$  is the number of adjacent  
 29 carriers supported by the base station. For a receiver that is not capable of  
 30 receiving more than one carrier at a time,  $n$  shall be equal to one.
- 31 10. If the base station receiver is capable of being configured to receive only one  
 32 Reverse CDMA Channel (even if the receiver is capable of receiving more than

---

<sup>9</sup> When interference is due only from CDMA transmitters, the limiting factor is the spectral density of the sideband noise of the mobile station transmitter, which is around 30 dB below the transmitted power spectral density.

<sup>10</sup> For Femto Cells with one input port, only one of the two Rx inputs into the Base Station under test in the figure shall be used.

1           one Reverse CDMA Channel) then perform step 12 for a single Reverse CDMA  
2           Channel located within the receiver pass band. A sufficient number of  
3           different CDMA frequency assignments for the Reverse CDMA Channel shall  
4           be tested to ensure compliance across the entire receiver pass band.

5           11. If the base station receiver is capable of being configured to receive adjacent  
6           (1.23, 1.24, or 1.25 MHz spacing) Reverse CDMA Channels, then for each  
7           possible receiver configuration of n adjacent carriers (i.e. n = 2, 3, ...), perform  
8           step 12 for a block of n adjacent Reverse CDMA Channels located within the  
9           receiver pass band<sup>11</sup>. A sufficient number of adjacent channel blocks shall be  
10          tested to ensure compliance across the entire receiver pass band.

11          12. For the band class and band subclass under test, adjust the CW generator  
12          relative to the level in step 8 and measure the mobile station simulator  
13          output power and FER of the base station receiver for each carrier (f1 through  
14          f2) and each permutation shown in the table below:

15

---

<sup>11</sup> For example, if the receiver supports operation with two or three adjacent carriers, then the receiver would be tested while receiving two carriers and again while receiving three carriers.

<b>Band Class and Band Subclass</b>	<b>CW Generator Power Above Mobile Station Simulator Output Power</b>	<b>CW Generator Frequencies</b>
0 (except Band Subclass 0 for China)	50 dB	$f_1 - 750 \text{ kHz}$ and $f_2 + 750 \text{ kHz}$
	Macro Cell BS: 87 dB Pico Cell BS: 71 dB Femto Cell: 65 dB	$f_1 - 900 \text{ kHz}$ and $f_2 + 900 \text{ kHz}$
0 (Band Subclass 0 for China)	50 dB	$f_1 - 750 \text{ kHz}$ and $f_2 + 750 \text{ kHz}$
	Macro Cell BS: 87 dB Pico Cell BS: 71 dB Femto Cell: 65 dB	$f_1 - 1.11 \text{ MHz}$ and $f_2 + 1.11 \text{ MHz}$
1, 4, 6, 7, 8, 10, 14, and 15	Macro Cell BS: 80 dB Pico Cell BS: 71 dB Femto Cell: 65 dB	$f_1 - 1.25 \text{ MHz}$ and $f_2 + 1.25 \text{ MHz}$
2, 3, 5, 9, 11, and 12	Macro Cell BS: 87 dB Pico Cell BS: 71 dB Femto Cell: 65 dB	$f_1 - 900 \text{ kHz}$ and $f_2 + 900 \text{ kHz}$

For single-carrier testing,  $f_1$  and  $f_2$  are both equal to the CDMA frequency assignment for the Reverse CDMA Channel under test.

For multiple adjacent carrier testing,  $f_1$  is the lowest CDMA frequency assignment in a block of adjacent Reverse CDMA Channels and  $f_2$  is the highest CDMA frequency assignment in a block of adjacent Reverse CDMA Channels under test.

For Band Classes 1, 4, 6, 7, 8, 10, 14, and 15 tests, the test is performed with maximum output power of the femto cell limited to 17 dBm.

1

### 2 3.7.3.3 Minimum Standard

3 For every Reverse CDMA Channel under test, the output power of the mobile station  
4 simulator shall increase by no more than 3 dB and the FER shall be less than 1.5%  
5 with 95% confidence (see 6.8).

### 6 3.7.4 Intermodulation Spurious Response Attenuation

#### 7 3.7.4.1 Definition

8 The intermodulation spurious response attenuation is a measure of a receiver's ability  
9 to receive a CDMA signal on its assigned channel frequency in the presence of two  
10 interfering CW tones. These tones are separated from the assigned channel frequency  
11 and from each other such that the third order mixing of the two interfering CW tones  
12 can occur in the non-linear elements of the receiver, producing an interfering signal  
13 in the band of the desired CDMA signal.

1 For the case of multiple adjacent carrier receivers, the test places the CW tones  
2 outside the bandwidth of the base station receiver, which is approximately  $n \times 1.25$   
3 MHz, where  $n$  is the number of adjacent carriers.

#### 4 3.7.4.2 Method of Measurement

5 Refer to Figure 6.5.1-4 for a functional block diagram of the test setup.

- 6 1. Configure the base station under test and a mobile station simulator as  
7 shown in Figure 6.5.1-4<sup>12</sup>.
- 8 2. For each band class that the base station supports, configure the base  
9 station to operate in that band class and perform steps 3 through 9.
- 10 3. Adjust the equipment to ensure path losses of at least 100 dB. All power  
11 control mechanisms shall be enabled and set at nominal values.
- 12 4. If the base station supports demodulation of Radio Configuration 1, 2, 3, or 4,  
13 set up a call using Fundamental Channel Test Mode 1 or 3 or Dedicated  
14 Control Channel Test Mode 3 (see 1.3) and perform steps 6 through 9.
- 15 5. If the base station supports demodulation of Radio Configuration 5 or 6, set  
16 up a call using Fundamental Channel Test Mode 7 or Dedicated Control  
17 Channel Test Mode 7 (see 1.3) and perform steps 6 through 10.
- 18 6. Transmit random data to the mobile station simulator at full data rate.
- 19 7. Measure the mobile station simulator output power at the RF input ports.
- 20 8. For each block of  $n$  adjacent (1.23 or 1.25 MHz spacing) carriers (including  $n$   
21 = 1), define the lowest frequency,  $f_1$ , as the lowest CDMA frequency  
22 assignment and the highest frequency,  $f_2$ , as the highest CDMA frequency  
23 assignment and perform step 9 and 10.
- 24 9. For the band class and band subclass under test, adjust each CW generator  
25 relative to the level measured in step 7 and measure the mobile station  
26 simulator output power and FER of the base station receiver for each  
27 permutation shown in the table below:

28

---

<sup>12</sup> For Femto Cells with one input port, only one of the two Rx inputs into the Base Station under test in the figure shall be used.

<b>Band Class and Band Subclass</b>	<b>CW Generator Power Above Mobile Station Simulator Output Power</b>	<b>CW Generator Frequency Pairs</b>
0 (except Band Subclass 0 for China), 2, 3, 5, 9, and 11	Macro Cell BS: 72 dB Pico Cell BS and Femto Cell: 63 dB	$f_2 + 900 \text{ kHz}$ and $f_2 + 1700 \text{ kHz} + i \times 1250 \text{ kHz}$
		$f_1 - 900 \text{ kHz}$ and $f_1 - 1700 \text{ kHz} - i \times 1250 \text{ kHz}$
0 (Band Subclass 0 for China)	Macro Cell BS: 72 dB Pico Cell BS and Femto Cell: 63 dB	$f_2 + 1110 \text{ kHz}$ and $f_2 + 1910 \text{ kHz} + i \times 1250 \text{ kHz}$
		$f_1 - 1110 \text{ kHz}$ and $f_2 - 1910 \text{ kHz} - i \times 1250 \text{ kHz}$
1, 4, 6, 8, 14, and 15	Macro Cell BS: 70 dB Pico Cell BS and Femto Cell: 63 dB	$f_2 + 1.25 \text{ MHz}$ and $f_2 + 2.05 \text{ MHz} + i \times 1.25 \text{ MHz}$
		$f_1 - 1.25 \text{ MHz}$ and $f_2 - 2.05 \text{ MHz} - i \times 1.25 \text{ MHz}$
7, 10, or 12	Macro Cell BS: 72 dB Pico Cell BS and Femto Cell: 63 dB	$f_2 + 1.25 \text{ MHz}$ and $f_2 + 2.05 \text{ MHz} + i \times 1.25 \text{ MHz}$
		$f_1 - 1.25 \text{ MHz}$ and $f_2 - 2.05 \text{ MHz} - i \times 1.25 \text{ MHz}$

In this table,  $i = 0, 1, \dots, n-1$ ; where  $n$  is the number of adjacent carriers.

1 10. Perform Step 10 for Femto Cells only.

2 For the band class and band subclass under test, adjust each CW generator  
 3 relative to the level measured in step 7 and measure the mobile station  
 4 simulator output power and FER of the base station receiver for each  
 5 permutation shown in the table below:

<b>Band Class and Band Subclass</b>	<b>CW Generator Power Above Mobile Station Simulator Output Power</b>	<b>CW Generator Frequency Pairs</b>
0 (except Band Subclass 0 for China), 2, 3, 5, 9, and 11	63 dB	$f_2 + 900 \text{ kHz}$ and $f_2 + 1400 \text{ kHz} + i \times 1250 \text{ kHz}$
		$f_1 - 900 \text{ kHz}$ and $f_1 - 1400 \text{ kHz} - i \times 1250 \text{ kHz}$
0 (Band Subclass 0 for China)	63 dB	$f_2 + 1110 \text{ kHz}$ and $f_2 + 1910 \text{ kHz} + i \times 1250 \text{ kHz}$
		$f_1 - 1110 \text{ kHz}$ and $f_2 - 1910 \text{ kHz} - i \times 1250 \text{ kHz}$
1, 4, 6, 8, 14, and 15	63 dB	$f_2 + 1.25 \text{ MHz}$ and $f_2 + 1.5 \text{ MHz} + i \times 1.25 \text{ MHz}$
		$f_1 - 1.25 \text{ MHz}$ and $f_2 - 1.5 \text{ MHz} - i \times 1.25 \text{ MHz}$
7, 10, or 12	63 dB	$f_2 + 1.25 \text{ MHz}$ and $f_2 + 1.5 \text{ MHz} + i \times 1.25 \text{ MHz}$
		$f_1 - 1.25 \text{ MHz}$ and $f_2 - 1.5 \text{ MHz} - i \times 1.25 \text{ MHz}$

In this table,  $i = 0, 1, \dots, n-1$ ; where  $n$  is the number of adjacent carriers.

6

1 3.7.4.3 Minimum Standard

2 The output power of the mobile station simulator shall increase by no more than 3 dB  
3 and the FER shall be less than 1.5% with 95% confidence (see 6.8).

4 3.7.5 Adjacent Channel Selectivity

5 3.7.5.1 Definition

6 Adjacent channel selectivity is a measure of the ability to receive a CDMA signal on  
7 the assigned channel frequency in the presence of another interfering CDMA signal.

8 This test applies to Band Class 6 only.

9 3.7.5.2 Method of Measurement

10 Refer to Figure 6.5.1-8 for a functional block diagram of the test setup.

- 11 1. Configure the base station under test and mobile station simulator as shown  
12 in Figure 6.5.1-8<sup>13</sup>.
- 13 2. Adjust the equipment to ensure path losses of at least 100 dB. All power  
14 control mechanisms shall be enabled and set at nominal values.
- 15 3. If the base station supports demodulation of Radio Configuration 1 or 2, set  
16 up a call using Fundamental Channel Test Mode 1 (see 1.3) and perform  
17 steps 7 through 11.
- 18 4. If the base station supports demodulation of Radio Configuration 3 or 4, set  
19 up a call using Fundamental Channel Test Mode 3 or Dedicated Control  
20 Channel Test Mode 3 (see 1.3) and perform steps 7 through 11.
- 21 5. If the base station supports demodulation of Radio Configuration 5 or 6, set  
22 up a call using Fundamental Channel Test Mode 7 or Dedicated Control  
23 Channel Test Mode 7 (see 1.3) and perform steps 7 through 11.
- 24 6. Transmit random data to the assigned mobile station simulator at full data  
25 rate.
- 26 7. Measure the assigned mobile station simulator output power.
- 27 8. Perform steps 9 through 11 with the bandwidth of the receiver pass band  
28 used in steps 10 and 11 defined equal to  $n \times 1.25$  MHz, where  $n$  is the  
29 number of adjacent carriers supported by the base station. For a receiver  
30 that is not capable of receiving more than one carrier at a time,  $n$  shall be  
31 equal to one.
- 32 9. If the base station receiver is capable of being configured to receive only one  
33 Reverse CDMA Channel (even if the receiver is capable of receiving more than

---

<sup>13</sup> For Femto Cells with one input port, only one of the two Rx inputs into the Base Station under test in the figure shall be used.

1 one Reverse CDMA Channel) then perform step 11 for a single Reverse CDMA  
2 Channel located within the receiver pass band. A sufficient number of  
3 different CDMA frequency assignments for the Reverse CDMA Channel shall  
4 be tested to ensure compliance across the entire receiver pass band.

5 10. If the base station receiver is capable of being configured to receive adjacent  
6 (1.23, 1.24, or 1.25 MHz spacing) Reverse CDMA Channels, then for each  
7 possible receiver configuration of  $n$  adjacent carriers (i.e.  $n = 2, 3, \dots$ ), perform  
8 step 11 for a block of  $n$  adjacent Reverse CDMA Channels located within the  
9 receiver pass band<sup>14</sup>. A sufficient number of adjacent channel blocks shall be  
10 tested to ensure compliance across the entire receiver pass band.

11 11. Measure the assigned mobile station simulator output power and FER of the  
12 base station receiver with the interfering mobile station simulator adjusted to  
13 a power level of -53 dBm and a frequency of  $f_1 - 2.50$  MHz and  $f_2 + 2.50$  MHz.  
14 For single-carrier testing,  $f_1$  and  $f_2$  are both equal to the CDMA frequency  
15 assignment for the Reverse CDMA Channel under test. For multiple adjacent  
16 carrier testing,  $f_1$  is the lowest CDMA frequency assignment in a block of  
17 adjacent Reverse CDMA Channels and  $f_2$  is the highest CDMA frequency  
18 assignment in a block of adjacent Reverse CDMA Channels under test. The  
19 interfering mobile station simulator shall be one mobile station transmitting a  
20 full rate RC 3 signal.

### 21 3.7.5.3 Minimum Standard

22 The output power of the assigned mobile station simulator shall increase by no more  
23 than 3 dB and the FER shall be less than 1.5% with 95% confidence (see 6.8).

### 24 3.7.6 Receiver Blocking

#### 25 3.7.6.1 Definition

26 Receiver blocking is a measure of the ability to receive a CDMA signal on the assigned  
27 channel frequency in the presence of a single tone that is offset from the center  
28 frequency of the assigned channel on frequencies other than those of the adjacent  
29 channels.

30 This test applies to Band Class 6, 8, 9, and 13 only.

#### 31 3.7.6.2 Method of Measurement

32 Refer to Figure 6.5.1-3 for a functional block diagram of the test setup.

---

<sup>14</sup> For example, if the receiver supports operation with two or three adjacent carriers, then the receiver would be tested while receiving two carriers and again while receiving three carriers.

- 1 1. Configure the base station under test and a mobile station simulator as  
2 shown in Figure 6.5.1-3<sup>15</sup>.
- 3 2. Configure the base station to operate in that band class and perform steps 3  
4 through 13.
- 5 3. Adjust the equipment to ensure path losses of at least 100 dB. All power  
6 control mechanisms shall be enabled and set at nominal values.
- 7 4. If the base station supports demodulation of Radio Configuration 1 or 2, set  
8 up a call using Fundamental Channel Test Mode 1 (see 1.3) and perform  
9 steps 7 through 13.
- 10 5. If the base station supports demodulation of Radio Configuration 3 or 4, set  
11 up a call using Fundamental Channel Test Mode 3 or Dedicated Control  
12 Channel Test Mode 3 (see 1.3) and perform steps 7 through 13.
- 13 6. If the base station supports demodulation of Radio Configuration 5 or 6, set  
14 up a call using Fundamental Channel Test Mode 7 or Dedicated Control  
15 Channel Test Mode 7 (see 1.3) and perform steps 7 through 13.
- 16 7. Transmit random data to the mobile station simulator at full data rate.
- 17 8. Measure the mobile station simulator output power.
- 18 9. Adjust the CW generator power to be 75 dB above the mobile station  
19 simulator output power at the RF input ports as measured in step 8.
- 20 10. Perform steps 11 through 13 with the bandwidth of the receiver pass band  
21 used in steps 11 and 12 defined equal to  $n \times 1.25$  MHz, where  $n$  is the  
22 number of adjacent carriers supported by the base station. For a receiver  
23 that is not capable of receiving more than one carrier at a time,  $n$  shall be  
24 equal to one.
- 25 11. If the base station receiver is capable of being configured to receive only one  
26 Reverse CDMA Channel (even if the receiver is capable of receiving more than  
27 one Reverse CDMA Channel) then perform step 13 for a single Reverse CDMA  
28 Channel located within the receiver pass band with the CDMA frequency  
29 assignment of the Reverse CDMA Channel ( $f$ ), where  $f_1$  and  $f_2$  are equal to  $f$ . A  
30 sufficient number of different CDMA frequency assignments for the Reverse  
31 CDMA Channel shall be tested to ensure compliance across the entire  
32 receiver pass band.
- 33 12. If the base station receiver is capable of being configured to receive adjacent  
34 (1.23, 1.24, or 1.25 MHz spacing) Reverse CDMA Channels, then for each  
35 possible receiver configuration of  $n$  adjacent carriers (i.e.  $n = 2, 3, \dots$ ) define  $f_1$   
36 as the lowest CDMA frequency assignment in the block of adjacent Reverse  
37 CDMA Channels and  $f_2$  as the highest CDMA frequency assignment in the

---

<sup>15</sup> For Femto Cells with one input port, only one of the two Rx inputs into the Base Station under test in the figure shall be used.

- 1 block of adjacent Reverse CDMA Channels and perform step 13 for a block of  
 2 n adjacent Reverse CDMA Channels located within the receiver pass band<sup>16</sup>.
- 3 13. Step the CW generator frequency from  $f_a$  through  $f_b$  MHz (see table below) at 1  
 4 MHz intervals but skip frequencies between  $f_1 - 2.5$  MHz and  $f_2 + 2.5$  MHz  
 5 and measure the mobile station simulator output power of the base station  
 6 receiver.
- 7 14. Adjust the CW generator power to be 100 dB for Macro Cell BS or 91 dB for  
 8 Femto Cell and Pico Cell BS above the mobile station simulator output power  
 9 at the RF input ports as measured in step 8.
- 10 15. Step the CW generator frequency from 1 through  $f_c$  MHz and  $f_d$  MHz through  
 11 12.75 GHz (see table below) in 1 MHz steps and measure the mobile station  
 12 simulator output power of the base station receiver.

13

Operating Band	$f_a$ [MHz]	$f_b$ [MHz]	$f_c$ [MHz]	$f_d$ [MHz]
BC 6	1900	2000	1899	2001
BC 8	1690	1805	1689	1806
BC 9	860	925	859	926
BC 13	2480	2590	2479	2591

14

### 15 3.7.6.3 Minimum Standard

16 The output power of the mobile station simulator shall increase by no more than 3 dB  
 17 from the measurement in step 8.

## 18 3.8 Limitations on Emissions

### 19 3.8.1 Conducted Spurious Emissions

#### 20 3.8.1.1 Definition

21 Conducted spurious emissions are spurious emissions generated or amplified in the  
 22 base station equipment and appearing at the receiver RF input ports.

#### 23 3.8.1.2 Method of Measurement

- 24 1. Connect a spectrum analyzer (or other suitable test equipment) to a receiver  
 25 RF input port.

---

<sup>16</sup> For example, if the receiver supports operation with two or three adjacent carriers, then the receiver would be tested while receiving two carriers and again while receiving three carriers.

- 1        2. For each band class that the base station supports, configure the base  
2            station to operate in that band class and perform steps 3 through 5.
- 3        3. Disable all transmitter RF outputs.
- 4        4. Perform step 5 for all receiver input ports.
- 5        5. Sweep the spectrum analyzer over a frequency range from the lowest  
6            intermediate frequency or lowest oscillator frequency used in the receiver or 1  
7            MHz, whichever is lower, to at least 2600 MHz for Band Classes 0, 2, 5, 7, 9,  
8            10, and 12, 3 GHz for Band Class 3, or 6 GHz for Band Classes 1, 4, 6, 8, 12,  
9            14, and 15 and measure the spurious emission levels.

#### 10    3.8.1.3 Minimum Standard

11    The conducted spurious emissions shall be

- 12    1. Less than -80 dBm, measured in a 30 kHz resolution bandwidth at the base  
13        station RF input ports, for frequencies within the base station receiver band (see  
14        3.1) associated with each band class that the base station supports.
- 15    2. Less than -60 dBm, measured in a 30 kHz resolution bandwidth at the base  
16        station RF input ports, for frequencies within the base station transmit band  
17        (see 3.1) associated with each band class that the base station supports.
- 18    3. Less than -41 dBm, measured in a 300 kHz resolution bandwidth at the base  
19        station RF input ports, for frequencies within the PHS band from 1884.5 to  
20        1919.6 MHz associated with Band Class 6 base stations operating under Japan  
21        regional specifications. Note that this is more stringent than ITU Category B  
22        emission limits.
- 23    4. For base stations that support other than Band Class 6, less than -47 dBm,  
24        measured in a 30 kHz resolution bandwidth at the base station RF input ports,  
25        for all other frequencies. For base stations that support Band Class 6, then -57  
26        dBm/100 kHz for frequencies from 30 MHz to 1 GHz and -47 dBm/1 MHz for  
27        frequencies from 1 GHz to 12.75 GHz<sup>17</sup>.

28    Current region-specific radio regulation rules shall also apply.

29    For example, a Band Class 6 base station operating under Japan regional  
30    requirements shall limit conducted emissions to less than -41 dBm, measured in a  
31    300 kHz resolution bandwidth at the base station RF input ports, for frequencies  
32    within the PHS band from 1884.5 to 1919.6 MHz.

---

<sup>17</sup> With the exception of frequencies used by the BS between 4 MHz below the first carrier frequency and 4 MHz above the last carrier frequency when the BS is operating in Spreading Rate 1 mode, and 12.5 MHz below the first carrier frequency and 12.5 MHz above the last carrier frequency when the BS is operating in Spreading Rate 3 mode.

### 3.8.2 Radiated Spurious Emissions

No receiver radiated spurious emissions are explicitly stated. In general, received radiated spurious emissions are tested together with transmitter radiated spurious emissions (see 4.4.2).

Current region-specific radio regulation rules shall apply.

For example, a Band Class 7 base station operating under US regional requirements shall limit radiated spurious emissions to less than  $-70$  dBW/MHz EIRP in the GPS band from 1559 to 1610 MHz.

## 3.9 Received Signal Quality Indicator (RSQI)

### 3.9.1 Definition

Received signal quality indicator (RSQI) refers to a measurement of signal quality performed by base stations. RSQI measurement results are used for comparisons of signal strength between different base stations.

Signal quality is defined as the combined signal energy to noise density ratio  $E_b/N_0$ . Signal quality shall be computed by adding together the individual  $E_b/N_0$  values from multipath components. RSQI shall be reported as a 6-bit unsigned integer, calculated as follows:

$$\frac{E_b}{N_0} = \frac{\text{Energy per Bit}}{\text{Noise + Interference Power}} \times 1.23 \text{ MHz for Spreading Rate 1}$$

$$\frac{E_b}{N_0} = \frac{\text{Energy per Bit}}{\text{Noise + Interference Power}} \times 3.69 \text{ MHz for Spreading Rate 3}$$

$$\left\{ \begin{array}{ll} 0, & \frac{E_b}{N_0} \leq 1 \\ 63, & \frac{E_b}{N_0} \geq 10^{3.15} \\ \left\lfloor 20 \times \log_{10} \left( \frac{E_b}{N_0} \right) \right\rfloor & \text{otherwise} \end{array} \right.$$

where the signal energy and noise power are measured within the CDMA bandwidth.

### 3.9.2 Method of Measurement

Refer to Figure 6.5.1-1 for a functional block diagram of the test setup.

- 1 1. Configure the base station under test and a mobile station simulator as  
2 shown in Figure 6.5.1-1<sup>18</sup>.
- 3 2. Disable reverse link closed loop power control in the mobile station simulator.
- 4 3. For each band class that the base station supports, configure the base  
5 station to operate in that band class and perform steps 4 through 14.
- 6 4. If the base station supports demodulation of Radio Configuration 1, set up a  
7 call using Fundamental Channel Test Mode 1 (see 1.3) and perform steps 10  
8 through 14.
- 9 5. If the base station supports demodulation of Radio Configuration 2, set up a  
10 call using Fundamental Channel Test Mode 2 (see 1.3) and perform steps 10  
11 through 14.
- 12 6. If the base station supports demodulation of Radio Configuration 3, set up a  
13 call using Fundamental Channel Test Mode 3 or Dedicated Control Channel  
14 Test Mode 3 (see 1.3) and perform steps 10 through 14.
- 15 7. If the base station supports demodulation of Radio Configuration 4, set up a  
16 call using Fundamental Channel Test Mode 5 or Dedicated Control Channel  
17 Test Mode 5 (see 1.3) and perform steps 10 through 14.
- 18 8. If the base station supports demodulation of Radio Configuration 5, set up a  
19 call using Fundamental Channel Test Mode 7 or Dedicated Control Channel  
20 Test Mode 7 (see 1.3) and perform steps 10 through 14.
- 21 9. If the base station supports demodulation of Radio Configuration 6, set up a  
22 call using Fundamental Channel Test Mode 9 or Dedicated Control Channel  
23 Test Mode 9 (see 1.3) and perform steps 10 through 14.
- 24 10. Adjust the AWGN generators for a noise power spectral density of -84  
25 dBm/1.23 MHz  $\pm$ 5 dB for Spreading Rate 1 or -84 dBm/3.69 MHz  $\pm$ 5 dB for  
26 Spreading Rate 3 and adjust the other equipment for an  $E_b/N_0$  of 8 dB at  
27 each RF input terminal.
- 28 11. Transmit random data to the mobile station simulator at full data rate.
- 29 12. Record the RSQI reported by the base station.
- 30 13. Reduce the mobile station simulator output power by 6 dB.
- 31 14. Record the RSQI reported by the base station.
- 32 15. Increase the mobile station simulator output power by 1 dB.
- 33 16. Repeat steps 14 and 15 until the  $E_b/N_0$  per antenna reaches 14 dB.

---

<sup>18</sup> For Femto Cells with one input port, only one of the two Rx inputs into the Base Station under test in the figure shall be used.

1 3.9.3 Minimum Standard

2 The reported RSQI shall be within the bounds shown in Table 3.9.3-1. For  $E_b/N_0$   
 3 greater than 14 dB the RSQI reports should be monotonically increasing or  
 4 unchanging.

5  
 6 **Table 3.9.3-1. Bounds on RSQI Reports**

<b><math>E_b/N_0</math> (dB) per Input Port</b>	<b>Minimum Acceptable Report Value</b>	<b>Maximum Acceptable Report Value</b>
2	6	14
3	8	16
4	10	18
5	12	20
6	14	22
7	16	24
8	18	26
9	20	28
10	22	30
11	24	32
12	26	34
13	28	36
14	30	38

7

8

1 This page intentionally left blank.

2

## 4 CDMA TRANSMITTER MINIMUM STANDARDS

Unless otherwise specified, all tests in this section shall be performed with a single antenna connector enabled for output.

### 4.1 Frequency Requirements

#### 4.1.1 Frequency Coverage

Channel frequencies and designations are given for CDMA base stations and mobile stations in 3.1. The base station receiver CDMA frequency assignments are associated on a one-to-one basis with the transmitter CDMA frequency assignments. Each CDMA frequency assignment shall be centered at one of the indicated frequencies. Note that the base station transmitter may be fixed to a specific CDMA frequency assignment or may be designed to cover a subset of the available frequency assignments. The base station shall support either the primary or the secondary CDMA Channel, or both.

#### 4.1.2 Frequency Tolerance

##### 4.1.2.1 Definition

Frequency tolerance is defined as the maximum allowed difference between the actual CDMA transmit carrier frequency and the specified CDMA transmit frequency assignment. This test shall apply to every band class that the base station supports.

##### 4.1.2.2 Method of Measurement

Frequency shall be measured using appropriate test equipment with sufficient accuracy to ensure compliance with the minimum standard. Frequency should be measured as part of the waveform quality test of 4.2.2.

##### 4.1.2.3 Minimum Standard

For all operating temperatures specified by the manufacturer, the average frequency difference between the actual CDMA transmit carrier frequency and specified CDMA transmit frequency assignment shall be less than  $\pm 5 \times 10^{-8}$  of the frequency assignment ( $\pm 0.05$  ppm) for Macro Cell BS and shall be less than  $\pm 10 \times 10^{-8}$  of the frequency assignment ( $\pm 0.10$  ppm) for Pico Cell BS and Femto Cell.

### 4.2 Modulation Requirements

Waveform quality is tested by measuring the waveform quality  $\rho$ , as defined in 6.4.2.1, and code domain power as defined in 6.4.2.2. The range of values for the transmit waveform quality is from 1.0 for a perfect CDMA waveform to 0.0 for a non-CDMA signal. As an example, a base station with a 0.5 dB degradation in its transmit waveform would have a quality,  $\rho$ , of  $10^{-(0.5/10)} = 0.89$ .

1 4.2.1 Synchronization and Timing

2 4.2.1.1 Pilot Time Tolerance

3 Each base station shall use a time base reference from which all time-critical CDMA  
4 transmissions, including pilot PN sequences, frames, and Walsh functions, shall be  
5 derived. The time base reference shall be time-aligned to CDMA System Time, as described  
6 in 1.2 of [3]. Reliable external means should be provided at each base station to  
7 synchronize each base station time base reference to CDMA System Time. Each base  
8 station should use a frequency reference with sufficient accuracy to maintain time  
9 alignment to CDMA System Time. With the external source of CDMA System Time  
10 disconnected, the base station shall maintain transmit timing within  $\pm 10 \mu\text{s}$  of CDMA  
11 System Time for a period of not less than 8 hours. The base station shall make available an  
12 even second time reference signal for the purpose of synchronization testing.

13 4.2.1.1.1 Definition

14 Pilot time is defined as the estimate of CDMA System Time derived from observation of the  
15 pilot signal at the base station RF output port. Pilot time alignment error is the difference  
16 between the measured pilot time and the expected time, taking into account CDMA System  
17 Time and pilot offset.

18 4.2.1.1.2 Method of Measurement

19 Refer to Figure 6.5.1-5 for a functional block diagram of the test setup.

- 20 1. Connect the waveform quality test equipment to a base station RF output port.
- 21 2. For each available CDMA Channel (sectors or alternate frequencies), perform steps  
22 2 through 6.
- 23 3. Set the attenuator at an appropriate level for the test equipment.
- 24 4. Configure the base station to transmit the Pilot Channel(s) only. The PN offset(s) of  
25 the base station may be any value in accordance with 3.1.3.2.1 of [3].
- 26 5. Trigger the test equipment from the base station even second time reference signal.
- 27 6. Measure the pilot time alignment error using the test equipment described in  
28 6.4.2.1.

29 4.2.1.1.3 Minimum Standard

30 For all base stations the pilot time alignment error should be less than  $3 \mu\text{s}$  and shall be  
31 less than  $10 \mu\text{s}$ .

32 For base stations supporting multiple simultaneous CDMA Channels, the pilot time  
33 tolerance of all CDMA Channels radiated by a base station shall be within  $\pm 1 \mu\text{s}$  of each  
34 other.

#### 1 4.2.1.2 Pilot Channel to Code Channel Time Tolerance

##### 2 4.2.1.2.1 Definition

3 Pilot channel to code channel time tolerance is the permissible error in timing between the  
4 radiated pilot channel and the other code channels transmitted out of the RF output port  
5 containing the same pilot channel within one Forward CDMA Channel.

##### 6 4.2.1.2.2 Method of Measurement

- 7 1. Configure the base station according to the test model described in 6.5.2. Connect  
8 the RF output port containing the Forward Pilot Channel as shown in Figure 6.5.1-  
9 6.
- 10 2. For each band class that the base station supports, configure the base station to  
11 operate in that band class and perform steps 3 and 4.
- 12 3. Monitor the transmitter output with the code domain power test equipment as  
13 described in 6.4.2.2 and measure the relative timing of the active channels.
- 14 4. If the base station supports transmit diversity, configure the base station according  
15 to the test model described in 6.5.2. Connect the RF output ports as shown in  
16 Figure 6.5.1-7.

##### 17 4.2.1.2.3 Minimum Standard

18 For code channels on the same Forward CDMA Channel, the time error between the  
19 Forward Pilot Channel and all code channels transmitted out of the RF output port  
20 containing the Forward Pilot Channel shall be less than  $\pm 50$  ns.

21 For code channels on the same Forward CDMA Channel, the time error between the  
22 Transmit Diversity Pilot Channel and all code channels transmitted out of the RF output  
23 port containing the Transmit Diversity Pilot Channel shall be less than  $\pm 50$  ns.

24 For code channels on the same Forward CDMA Channel, the time error between the  
25 Auxiliary Pilot Channel and all code channels transmitted out of the RF output port  
26 containing the Auxiliary Pilot Channel shall be less than  $\pm 50$  ns.

27 For code channels on the same Forward CDMA Channel, the time error between the  
28 Auxiliary Transmit Diversity Pilot Channel and all code channels transmitted out of the RF  
29 output port containing the Auxiliary Transmit Diversity Pilot Channel shall be less than  
30  $\pm 50$  ns.

31 For code channels on the same Forward CDMA Channel, the time error between the  
32 Forward Pilot Channel and all code channels transmitted out of the RF output port  
33 containing the Transmit Diversity Pilot Channel, an Auxiliary Pilot Channel, or an Auxiliary  
34 Transmit Diversity Pilot Channel shall be less than  $\pm 100$  ns and should be less than  $\pm 50$   
35 ns.

1 4.2.1.3 Pilot Channel to Code Channel Phase Tolerance

2 4.2.1.3.1 Definition

3 Pilot Channel to code channel phase tolerance is the permissible error in RF phase between  
4 the radiated Pilot Channel and the other channels within one Forward CDMA Channel.

5 4.2.1.3.2 Method of Measurement

6 Refer to Figure 6.5.1-6 for a functional block diagram of the test setup.

- 7 1. Configure the base station according to the test model described in 6.5.2.
- 8 2. For each band class that the base station supports, configure the base station to  
9 operate in that band class and perform step 3.
- 10 3. Monitor the transmitter output with the code domain power test equipment as  
11 described in 6.4.2.2 and measure the relative phase of the active channels.

12 4.2.1.3.3 Minimum Standard

13 The phase differences between the Pilot Channel and all other code channels sharing the  
14 same Forward CDMA Channel should not exceed 0.05 radians and shall not exceed 0.15  
15 radians.

16 4.2.2 Waveform Quality

17 4.2.2.1 Definition

18 Waveform quality is measured by determining the normalized correlated power between the  
19 actual waveform and the ideal waveform.

20 4.2.2.2 Method of Measurement

21 Refer to Figure 6.5.1-5 for a functional block diagram of the test setup.

- 22 1. Connect the base station RF output port that contains the Forward Pilot Channel  
23 to the test equipment described in 6.4.2.1.
- 24 2. For each band class that the base station supports, configure the base station to  
25 operate in that band class and perform steps 3 through 6.
- 26 3. Configure the base station to transmit the Forward Pilot Channel only and perform  
27 steps 5 and 6.
- 28 4. If the base station supports transmit diversity, connect the base station RF output  
29 port that contains the Transmit Diversity Pilot Channel to the test equipment  
30 described in 6.4.2.1. Configure the base station to transmit the Transmit Diversity  
31 Pilot Channel only and perform steps 5 and 6.
- 32 5. Trigger the test equipment from the system time reference signal from the base  
33 station.
- 34 6. Measure the waveform quality factor.

### 4.2.2.3 Minimum Standard

For all base stations, the normalized cross correlation coefficient,  $\rho$ , shall be greater than 0.912 (excess power < 0.4 dB).

For base stations supporting Radio Configuration 10, the normalized cross correlation coefficient,  $\rho$ , shall be greater than 0.97 (excess power < 0.13 dB).

Base stations supporting Radio Configuration 10 and a data rate of 3.0912 Mbps shall meet one of the following requirements:

1. If  $|\Delta f| > 750$  kHz, where  $\Delta f$  is the frequency difference between the CDMA center frequency and the closest band or block edge<sup>19</sup>, the normalized cross correlation coefficient,  $\rho$ , shall be greater than 0.985 (excess power < 0.066 dB).
2. If  $|\Delta f| \leq 750$  kHz, where  $\Delta f$  is the frequency difference between the CDMA center frequency and the closest band or block edge, the normalized cross correlation coefficient,  $\rho$ , shall be greater than 0.97 (excess power < 0.13 dB).

### 4.2.3 Forward Power Control Subchannel

#### 4.2.3.1 Definition

The Forward Power Control Subchannel test ensures that the power control bits described in Section 3.1.3.1.10 of [3] have the correct sense, position, delay, and amplitude.

#### 4.2.3.2 Method of Measurement

Standard Procedure:

Refer to Figure 6.5.1-1 for a functional block diagram of the test setup.

1. Configure the base station according to the test model described in 6.5.2.
2. Disable closed loop power control in the mobile station simulator. If the base station under test has a mechanism for the adjustment of the reverse link  $E_b/N_0$  setpoint, it shall be disabled for this test.
3. For each band class that the base station supports, configure the base station to operate in that band class and perform steps 4 through 12.
4. If the base station supports demodulation of Radio Configuration 1, set up a call using Fundamental Channel Test Mode 1 (see 1.3) and perform steps 8 through 12.
5. If the base station supports demodulation of Radio Configuration 2, set up a call using Fundamental Channel Test Mode 2 (see 1.3) and perform steps 8 through 12.

---

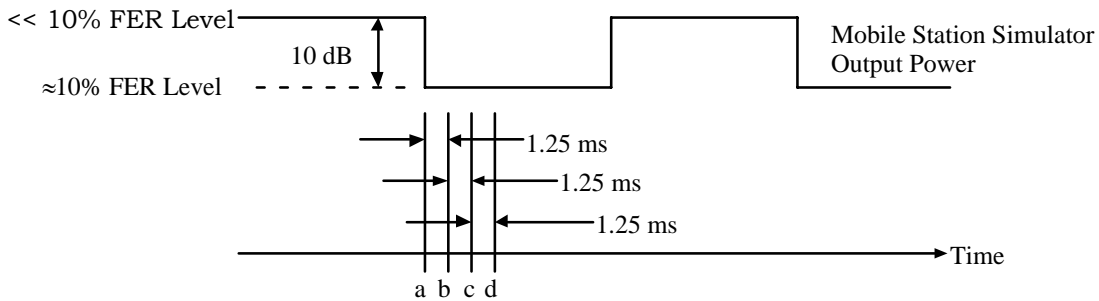
<sup>19</sup> Currently, the only preferred CDMA channel requiring the relaxed 0.97 rho requirement is Channel 777 in Band Class 0.

- 1       6. If the base station supports demodulation of Radio Configuration 3 or 4, set up a  
2       call using Fundamental Channel Test Mode 3 or Dedicated Control Channel Test  
3       Mode 3 (see 1.3) and perform steps 8 through 12.
- 4       7. If the base station supports demodulation of Radio Configuration 5 or 6, set up a  
5       call using Fundamental Channel Test Mode 7 or Dedicated Control Channel Test  
6       Mode 7 (see 1.3) and perform steps 8 through 12.
- 7       8. Set the AWGN generators to yield a noise power spectral density of -84 dBm/1.23  
8       MHz  $\pm$ 5 dB at each base station RF input port.
- 9       9. Transmit random data to the mobile station simulator at full data rate.
- 10      10. Adjust the mobile station simulator output power until the base station measures  
11      approximately 10% FER.
- 12      11. Start the power control test program in the mobile station simulator as described  
13      in 6.4.3. The mobile station simulator output power shall cycle between the level  
14      set in Step 10 and 10 dB higher as shown in Figure 4.2.3.2-1.
- 15      12. Count the occurrences of power up and power down control bits relative to mobile  
16      station simulator time reference pulses.

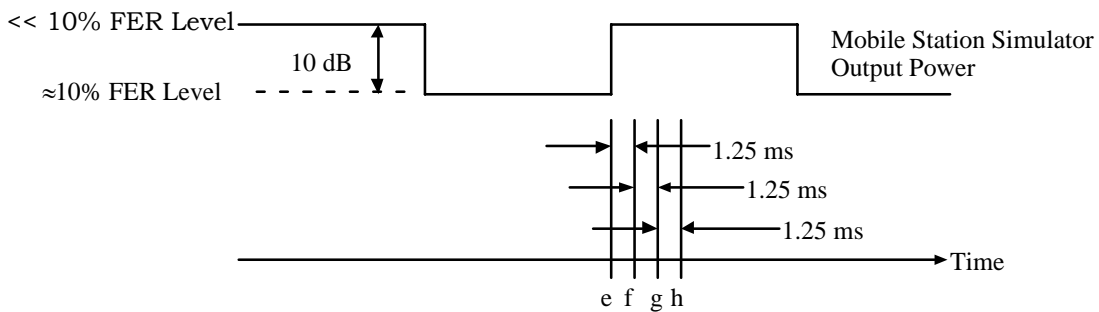
17   Alternative Procedure:

- 18      1. Configure the base station according to the test model described in 6.5.2 with only  
19      one traffic channel activated.
- 20      2. Enable closed loop power control in the mobile station simulator. If the base  
21      station under test has a mechanism for adjusting the reverse link  $E_b/N_0$  setpoint,  
22      it shall be disabled for this test.
- 23      3. For each band class that the base station supports, configure the base station to  
24      operate in that band class and perform steps 4 through 13.
- 25      4. If the base station supports demodulation of Radio Configuration 1, set up a call  
26      using Fundamental Channel Test Mode 1 (see 1.3) and perform steps 8 through  
27      13.
- 28      5. If the base station supports demodulation of Radio Configuration 2, set up a call  
29      using Fundamental Channel Test Mode 2 (see 1.3) and perform steps 8 through  
30      13.
- 31      6. If the base station supports demodulation of Radio Configuration 3 or 4, set up a  
32      call using Fundamental Channel Test Mode 3 or Dedicated Control Channel Test  
33      Mode 3 (see 1.3) and perform steps 8 through 13.
- 34      7. If the base station supports demodulation of Radio Configuration 5 or 6, set up a  
35      call using Fundamental Channel Test Mode 7 or Dedicated Control Channel Test  
36      Mode 7 (see 1.3) and perform steps 8 through 13.
- 37      8. Set the AWGN generators to yield a noise power spectral density of -84  
38      dBm/1.23MHz  $\pm$ 5 dB at each base station RF input port.
- 39      9. Transmit random data to the mobile station simulator at full data rate.

- 1 10. Adjust the mobile station simulator output power until the base station measures
- 2 approximately 1% FER.
- 3 11. Decrease the reverse link path loss between the mobile station simulator and the
- 4 base station RF input ports by 10 dB for 5 ms. Increase the path loss by 20 dB to a
- 5 level 10 dB greater than the original path loss for 5 ms. Decrease the path loss by
- 6 20 dB to a level 10 dB less than the original path loss. Changes in path loss shall
- 7 occur on power control group boundaries.
- 8 12. Measure and record the output power of the mobile station simulator at each test
- 9 point. The timing of the test points relative to the reverse link path loss is shown in
- 10 Figure 4.2.3.2-2. The timing of the test points may be delayed up to 200  $\mu$ s, as
- 11 indicated by the interval Z-A in Figure 4.2.3.2-2, to compensate for the response
- 12 time of the mobile station to power control bits.
- 13 13. Repeat steps 4 through 12 until sufficient confidence is assured. This requires
- 14 setting up a new call for each trial.

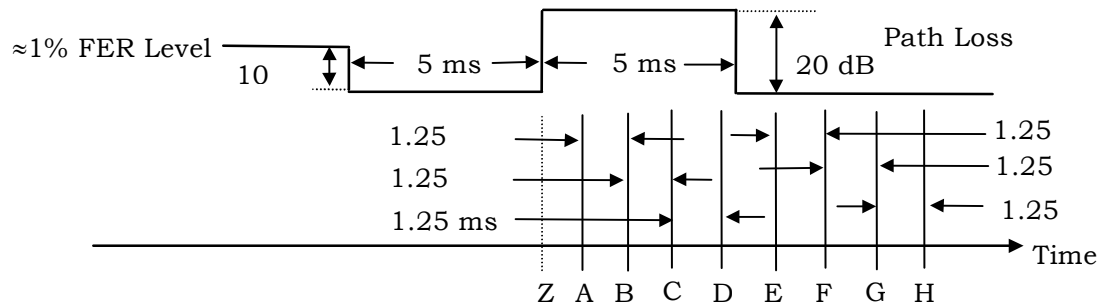


16 **Figure 4.2.3.2-1. Power Up Command Measurement Interval (Part 1 of 2)**



19 **Figure 4.2.3.2-1. Power Down Command Measurement Interval (Part 2 of 2)**

21



**Figure 4.2.3.2-2. Path Loss Increase and Decrease Responses and the Test Points for the Alternative Test Procedure**

#### 4.2.3.3 Minimum Standard

##### Standard Procedure:

In Figure 4.2.3.2-1, interval b-c is the second and interval c-d is the third power control group following the drop in mobile station simulator output power. Interval f-g is the second and interval g-h is the third power control group following the rise in mobile station simulator output power. Within each power control group there will be one power control subchannel bit transmitted by the base station.

Of all the power control bits transmitted by the base station in intervals b-c and c-d, 70% or more shall be power up commands. Of all the power control bits transmitted by the base station in intervals f-g and g-h, 90% or more shall be power down commands.

The amplitude of the power control symbols shall be at least as large as the full rate data symbols independent of the data rate being transmitted on the Forward Traffic Channel.

##### Alternative Procedure:

The interval of test points A-B, B-C, C-D, D-E, E-F, F-G, and G-H in Figure 4.2.3.2-2 shall each be 1.25 ms. Calculate the average output power of test points B, C, D, F, G, and H, and denote the results as  $P_B$ ,  $P_C$ ,  $P_D$ ,  $P_F$ ,  $P_G$ , and  $P_H$ , respectively. The values of  $P_C - P_B$ ,  $P_D - P_C$ ,  $P_F - P_G$ , and  $P_G - P_H$  shall be within the range of  $1.0 \pm 0.3$  dB.

### 4.3 RF Output Power Requirements

#### 4.3.1 Total Power

##### 4.3.1.1 Definition

Base station total power is the mean power delivered to a load with resistance equal to the nominal load impedance of the transmitter.

##### 4.3.1.2 Method of Measurement

1. Connect the power measuring equipment to the base station RF output port.

- 1       2. For each band class that the base station supports, configure the base station to  
2       operate in that band class and perform steps 3 and 4.
- 3       3. Set the base station to transmit a signal modulated with a combination of code  
4       channels as stated in 6.5.2.
- 5       4. For each radio configurations that the base station supports, measure the mean  
6       power at the RF output port.

#### 7   4.3.1.3 Minimum Standard

8   The total power shall remain within +2 dB and -4 dB of the manufacturer's rated power for  
9   the equipment over the environmental conditions described in Section 5.

10   The output power of Pico BS shall be less than or equal to +24 dBm.

11   The output power of Femto Cell not exceed +20 dBm average conducted power as  
12   measured at the RF output connector.

13   The single-antenna femto cell base station radiated power shall not exceed +27 dBm EIRP  
14   average maximum power in any direction. This requirement shall only apply until such  
15   time that fading demodulation tests are added to Section 3 of this specification for single-  
16   antenna Femto Cells.

#### 17   4.3.2 Pilot Power

##### 18   4.3.2.1 Definition

19   The Pilot Channel power to total power ratio is the power attributed to the Pilot Channel  
20   divided by the total power, and is expressed in dB. The Code Domain Power Analyzer is  
21   used to determine the ratio of the Pilot Channel power to the total power. This equipment is  
22   described in 6.4.2.2.

##### 23   4.3.2.2 Method of Measurement

- 24       1. Connect the base station RF output port to the Code Domain Power Analyzer using  
25       an attenuator or directional coupler if necessary.
- 26       2. For each band class that the base station supports, configure the base station to  
27       operate in that band class and perform steps 3 and 4.
- 28       3. Configure the base station to transmit a signal modulated with a combination of  
29       Pilot, Sync, Paging, and Traffic Channels as described in 6.5.2.
- 30       4. Measure the Pilot Channel power to total power ratio.

##### 31   4.3.2.3 Minimum Standard

32   The Pilot Channel power to total power ratio shall be within  $\pm 0.5$  dB of the configured  
33   value.

### 4.3.3 Code Domain Power

#### 4.3.3.1 Definition

Code domain power is the power in each code channel of a CDMA Channel. The CDMA time reference used in the code domain power test is derived from the Pilot Channel and is used as the reference for demodulation of all other code channels. This test verifies that orthogonality is maintained between the code channels. When transmit diversity is enabled, this test also verifies that time alignment is maintained.

#### 4.3.3.2 Method of Measurement

1. Configure the base station to operate in that band class as shown in Figures 6.5.1-6 and 6.5.1-7.
2. For each band class that the base station supports, configure the base station to operate in that band class and perform steps 3 through 5.
3. Set the base station to transmit a signal modulated with a combination of code channels as stated in 6.5.2. Total power at the RF output port shall be the maximum power as specified by the manufacturer.
4. Measure the base station transmitter output at the RF output port with a Code Domain Power Analyzer described in 6.4.2.2 with transmit diversity disabled.
5. If the base station supports transmit diversity for the radio configuration under test, measure the base station transmitter output at the RF output port with a Code Domain Power Analyzer described in 6.4.2.2 with transmit diversity enabled. Equal cabling delays shall be used when connecting the two antenna ports to the summer in Figure 6.5.1-7.

#### 4.3.3.3 Minimum Standard

If the base station supports Radio Configuration 10, then the mean code domain power in each inactive  $W_n^{64}$  channel shall be 31.5 dB or more below the total mean output power and the mean code domain power in each inactive  $W_n^{128}$  channel shall be 34.5 dB or more below the total mean output power.

If the base station supports Radio Configuration 10 and a data rate of 3.0912 Mbps, the base station shall meet one of the following requirements:

1. If  $|\Delta f| > 750$  kHz, where  $\Delta f$  is the frequency difference between the CDMA center frequency and the closest band or block edge<sup>20</sup>, the mean code domain power in each inactive  $W_n^{64}$  channel shall be 34.5 dB or more below the total mean output

---

<sup>20</sup> Currently, the only preferred CDMA channel requiring the relaxed code domain power requirement is Channel 777 in Band Class 0.

1 power and the mean code domain power in each inactive  $W_n^{128}$  channel shall be  
2 37.5 dB or more below the total mean output power.

3 2. If  $|\Delta f| \leq 750$  kHz, where  $\Delta f$  is the frequency difference between the CDMA center  
4 frequency and the closest band or block edge, the mean code domain power in  
5 each inactive  $W_n^{64}$  channel shall be 31.5 dB or more below the total mean output  
6 power and the mean code domain power in each inactive  $W_n^{128}$  channel shall be  
7 34.5 dB or more below the total mean output power.

8 When operating in Spreading Rate 1, the code domain power in each inactive  
9  $W_n^{64}$  channel shall be 27 dB or more below the total output power and the code domain  
10 power in each inactive  $W_n^{128}$  channel shall be 30 dB or more below the total output power.

11 When operating in Spreading Rate 3, the code domain power in each inactive  
12  $W_n^{256}$  channel shall be 33 dB or more below the total output power of each carrier.

#### 13 4.3.4 Femto Cell Transmission Authorization

##### 14 4.3.4.1 Definition

15 The transmitters of femto cells are only enabled after authorization from a Femto  
16 Management Server [7]. Authorization is only given after the the location of the femto cell  
17 is determined to be within the geographic area of the spectrum licensee.

18

19 This test only applies to femto cells.

##### 20 4.3.4.2 Method of Measurement

- 21 1. Connect the power measuring equipment to the base station RF output port and  
22 configure the base station so that it can connect with the Femto Management  
23 Server.
- 24 2. Configure the Femto Management Server so that it will not authorize the base  
25 station to transmit regardless of location.
- 26 3. Power up the base station, allow sufficient time to allow authorization as stated by  
27 the manufacturer, and measure the output power of the base station.
- 28 4. Configure the base station so that the location detection function is operational  
29 and set the location such that the Femto Management Server will permit  
30 authorization.
- 31 5. Configure the Femto Management Server to allow authorization of the base station  
32 if the location is acceptable.
- 33 6. Power up the base station, allow sufficient time to allow authorization as stated by  
34 the manufacturer, and measure the output power of the base station.

- 1       7.   Configure the base station so that the location detection function is operational but  
2       set the location such that the Femto Management Server will not allow  
3       authorization.
- 4       8.   Configure the Femto Management Server to allow authorization of the base station  
5       if the location is acceptable.
- 6       9.   Power up the base station, allow sufficient time to allow authorization as stated by  
7       the manufacturer, and measure the output power of the base station.

#### 8   4.3.4.3 Minimum Standard

9   In the cases where the base station power is measured and it is not authorized for  
10 operation (steps 3 and 9), the power output by the base station shall not exceed -30 dBm.

### 11 **4.4 Limitations on Emissions**

#### 12 4.4.1 Conducted Spurious Emissions

##### 13 4.4.1.1 Macro Cell Base Station

###### 14 4.4.1.1.1 Definition

15 Conducted spurious emissions are emissions at frequencies that are outside the assigned  
16 CDMA Channel, measured at the base station RF output port.

###### 17 4.4.1.1.2 Method of Measurement

- 18       1.   Connect a spectrum analyzer (or other suitable test equipment) to each base  
19       station RF output port, using an attenuator or directional coupler if necessary.
- 20       2.   For each band class that the base station supports, configure the base station to  
21       operate in that band class and perform steps 3 through 11.
- 22       3.   Configure the base station to transmit a single carrier and perform steps 4 through  
23       6.
- 24       4.   Set the base station to transmit a signal modulated with a combination of code  
25       channels as stated in 6.5.2. Total mean power at the RF output port shall be the  
26       maximum mean output power as specified by the manufacturer.
- 27       5.   Measure the power level at the carrier frequency.
- 28       6.   Measure the mean spurious emission levels. Integration measurement techniques  
29       of ten or more subintervals shall be used for measurement bandwidths of 100 kHz  
30       and greater to minimize errors induced by spectrum analyzer filter response.
- 31       7.   If the base station supports two carriers through a single RF output port with a  
32       carrier-to-carrier spacing of 1.23 MHz (Band Class 0) or 1.25 MHz (all other band  
33       classes), configure the base station to transmit two adjacent carriers and perform  
34       steps 10 and 11.
- 35       8.   If the base station supports two carriers through a single RF output port with a  
36       carrier-to-carrier spacing of greater than 1.23 MHz (Band Class 0) or 1.25 MHz (all

- 1 other band classes), configure the base station to transmit two non-adjacent  
2 carriers and perform steps 10 and 11.
- 3 9. If the base station supports three or more carriers through a single RF output port,  
4 configure the base station to transmit all carriers with the smallest carrier-to-  
5 carrier spacing specified by the manufacturer and perform steps 10 and 11.
- 6 10. Set the base station to transmit multiple signals modulated with a combination of  
7 Pilot, Sync, Paging, and Traffic Channels as stated in 6.5.2. Total mean power at  
8 the RF output port shall be the maximum mean output power as specified by the  
9 manufacturer for the multiple-carrier configuration under test.
- 10 11. For each radio configurations that the base station supports, measure the mean  
11 spurious emission levels with ten or more averages.

#### 12 4.4.1.1.3 Minimum Standard

13 When transmitting in Band Class 0, 2, 3, 5, 7, 9, or 10 the spurious emissions shall be less  
14 than all of the limits specified in Table 4.4.1.1.3-1. When transmitting in Band Class 1, 4,  
15 6, 8, 14, or 15 the spurious emissions shall be less than all of the limits specified in Table  
16 4.4.1.1.3-2. When transmitting in Band Class 11 and 12, mean spurious emissions shall  
17 be less than the limits specified in Table 4.4.1.1.3-3. When transmitting in Band Class 3,  
18 mean spurious emissions for a single carrier shall be less than the limits specified in Table  
19 4.4.1.1.3-4. When transmitting in Band Class 6, mean spurious emissions shall also be  
20 less than the limits specified in Table 4.4.1.1.3-5. When transmitting in Band Class 10,  
21 mean spurious emissions shall also be less than the limits specified in Table 4.4.1.1.3-6.

22

**Table 4.4.1.1. 3-1. Band Class 0, 2, 5, 7, 9, and 10 Transmitter Spurious Emission Limits**

For $ \Delta f $ Within the Range	Applies to Multiple Carriers	Emission Limit
750 kHz to 1.98 MHz	No	-45 dBc / 30 kHz
1.98 MHz to 4.00 MHz	No	-60 dBc / 30 kHz; $P_{out} \geq 33$ dBm -27 dBm / 30 kHz; $28$ dBm $\leq P_{out} < 33$ dBm -55 dBc / 30 kHz; $P_{out} < 28$ dBm
3.25 MHz to 4.00 MHz (Band Class 7 only)	Yes	-46 dBm / 6.25 kHz
> 4.00 MHz (ITU Category A only)	Yes	-13 dBm / 1 kHz; 9 kHz < f < 150 kHz -13 dBm / 10 kHz; 150 kHz < f < 30 MHz -13 dBm/100 kHz; 30 MHz < f < 1 GHz -13 dBm / 1 MHz; 1 GHz < f < 5 GHz
> 4.00 MHz (ITU Category B only)	Yes	-36 dBm / 1 kHz; 9 kHz < f < 150 kHz -36 dBm / 10 kHz; 150 kHz < f < 30 MHz -30 dBm / 1 MHz; 1 GHz < f < 12.5 GHz
4.00 to 6.40 MHz (ITU Category B only)	Yes	-36 dBm / 1 kHz 30 MHz < f < 1 GHz
6.40 to 16 MHz (ITU Category B only)	Yes	-36 dBm / 10 kHz 30 MHz < f < 1 GHz
> 16 MHz (ITU Category B only)	Yes	-36 dBm / 100 kHz 30 MHz < f < 1 GHz

Note: All frequencies in the measurement bandwidth shall satisfy the restrictions on  $|\Delta f|$ . The emissions requirements shall apply for all values of  $\Delta f$  regardless of whether the measurement frequency falls inside or outside of the band or block edge. For single-carrier testing,  $\Delta f$  = center frequency - closer measurement edge frequency (f). For multiple-carrier testing,  $\Delta f$  is defined for positive  $\Delta f$  as the closer measurement edge frequency (f) - center frequency of the highest carrier and for negative  $\Delta f$  as the closer measurement edge frequency (f) - center frequency of the lowest carrier.

Compliance with the -46 dBm / 6.25 kHz limit is based on the use of measurement instrumentation such that the reading taken with any resolution bandwidth setting should be adjusted to indicate spectral power in a 6.25 kHz segment.

**Table 4.4.1.1.3-2. Band Class 1, 4, 6, 8, 14, and 15 Transmitter Spurious Emission Limits**

For $ \Delta f $ Within the Range	Applies to Multiple Carriers	Emission Limit
885 kHz to 1.25 MHz	No	-45 dBc / 30 kHz
1.25 to 1.98 MHz	No	More stringent of -45 dBc / 30 kHz or -9 dBm / 30 kHz
1.25 to 2.25 MHz (MC tests only)	Yes	-9 dBm / 30 kHz
1.25 to 1.45 MHz (Band Class 6 only)	Yes	-13 dBm / 30 kHz
1.45 to 2.25 MHz (Band Class 6 only)	Yes	$-[13 + 17 \times (\Delta f - 1.45 \text{ MHz})]$ dBm / 30 kHz
1.98 MHz to 2.25 MHz	No	-55 dBc / 30 kHz; $P_{out} \geq 33$ dBm -22 dBm / 30 kHz; $28 \text{ dBm} \leq P_{out} < 33$ dBm -50 dBc / 30 kHz; $P_{out} < 28$ dBm
2.25 MHz to 4.00 MHz	Yes	-13 dBm / 1 MHz
> 4.00 MHz (ITU Category A only)	Yes	-13 dBm / 1 kHz; 9 kHz < f < 150 kHz -13 dBm / 10 kHz; 150 kHz < f < 30 MHz -13 dBm/100 kHz; 30 MHz < f < 1 GHz -13 dBm / 1 MHz; 1 GHz < f < 5 GHz
> 4.00 MHz (ITU Category B only)	Yes	-36 dBm / 1 kHz; 9 kHz < f < 150 kHz -36 dBm / 10 kHz; 150 kHz < f < 30 MHz -36 dBm/100 kHz; 30 MHz < f < 1 GHz
4.00 to 16.0 MHz (ITU Category B only)	Yes	-30 dBm / 30 kHz; 1 GHz < f < 12.5 GHz
16.0 to 19.2 MHz (ITU Category B only)	Yes	-30 dBm / 300 kHz; 1 GHz < f < 12.5 GHz
> 19.2 MHz (ITU Category B only)	Yes	-30 dBm / 1 MHz; 1 GHz < f < 12.5 GHz

Note: All frequencies in the measurement bandwidth shall satisfy the restrictions on  $|\Delta f|$ . The emissions requirements shall apply for all values of  $\Delta f$  regardless of whether the measurement frequency falls inside or outside of the band or block edge. For single-carrier testing,  $\Delta f$  = center frequency - closer measurement edge frequency (f). For multiple-carrier testing,  $\Delta f$  is defined for positive  $\Delta f$  as the closer measurement edge frequency (f) - center frequency of the highest carrier and for negative  $\Delta f$  as the closer measurement edge frequency (f) - center frequency of the lowest carrier.

The -9 dBm requirement is based on CFR 47 Part 24 -13 dBm/12.5 kHz specification.

1 **Table 4.4.1.1.3-3. Band Class 11 and 12 Transmitter Spurious Emission Limits**

For $ \Delta f $ Within the Range	Applies to Multiple Carriers	Emission Limit
750 to 885 KHz	No	$-45-15( \Delta f -750)/135$ dBc in 30 kHz
885 to 1125 KHz	No	$-60-5( \Delta f -885)/240$ dBc in 30 kHz
1.125 to 1.98 MHz	No	-65 dBc / 30kHz
1.98 to 4.00 MHz	No	-75 dBc / 30kHz
4.00 to 6.00 MHz	Yes	-36 dBm / 100kHz
> 6.00 MHz	Yes	-36 dBm / 1 kHz; 9 kHz < f < 150 kHz -36 dBm / 10 kHz; 150 kHz < f < 30 MHz -45 dBm/100 kHz; 30 MHz < f < 1 GHz -30 dBm / 1 MHz; 1 GHz < f < 12.75 GHz

Note: All frequencies in the measurement bandwidth shall satisfy the restrictions on  $|\Delta f|$  where  $\Delta f$  = center frequency - closer measurement edge frequency (f).  $\Delta f$  is positive offset from the highest valid CDMA channel in the band subclass or negative offset from the lowest valid CDMA channel in the band subclass. The emission limits for Band Class 11 and 12 (European PAMR bands) are designed to allow co-existence with incumbent services in Europe and are tighter than ITU Category B requirements.

2

**Table 4.4.1.1.3-4. Band Class 3 Transmitter Spurious Emission Limits**

Measurement Frequency	Applies to Multiple Carriers	For $ \Delta f $ Within the Range	Emission Limit
> 832 MHz and $\leq$ 834 MHz, > 838 MHz and $\leq$ 846 MHz, > 860 MHz and $\leq$ 895 MHz	No	$\geq$ 750kHz and $<$ 1.98MHz	-45 dBc / 30 kHz
	No	$\geq$ 1.98 MHz	25 $\mu$ W (-16 dBm) / 100 kHz; Pout $\leq$ 30 dBm -60 dBc / 100 kHz; 30dBm < Pout $\leq$ 47 dBm Less stringent of 50 $\mu$ W (-13 dBm) / 100 kHz or -70 dBc / 100 kHz; Pout > 47 dBm
> 810 MHz and $\leq$ 860 MHz, except > 832 MHz and $\leq$ 834 MHz, > 838 MHz and $\leq$ 846 MHz	No	$<$ 1.98MHz	25 $\mu$ W (-16 dBm) / 30 kHz; Pout $\leq$ 30 dBm More stringent of -60 dBc / 30 kHz and 25 $\mu$ W (-16 dBm) / 30 kHz; Pout > 30 dBm
	No	$\geq$ 1.98 MHz	25 $\mu$ W (-16 dBm) / 100 kHz; Pout $\leq$ 30 dBm More stringent of -60 dBc / 100 kHz and 25 $\mu$ W (-16 dBm) / 100 kHz; Pout > 30 dBm
$\leq$ 810 MHz and > 895 MHz	Yes	N/A	25 $\mu$ W (-16 dBm) / 1 MHz; Pout $\leq$ 44 dBm -60 dBc / 1 MHz ; 44 dBm < Pout $\leq$ 47 dBm Less stringent of 50 $\mu$ W (-13 dBm) / 1 MHz or -70 dBc / 1 MHz; Pout > 47 dBm

Note: All frequencies in the measurement bandwidth shall satisfy the restrictions on  $|\Delta f|$ . The emissions requirements shall apply for all values of  $\Delta f$  regardless of whether the measurement frequency falls inside or outside of the band or block edge. For single-carrier testing,  $\Delta f$  = center frequency - closer measurement edge frequency (f). For multiple-carrier testing,  $\Delta f$  is defined for positive  $\Delta f$  as the closer measurement edge frequency (f) - center frequency of the highest carrier and for negative  $\Delta f$  as the closer measurement edge frequency (f) - center frequency of the lowest carrier. The upper and lower limits of the frequency measurement are currently 10 MHz and 3 GHz in Japan radio measurement documents.

**Table 4.4.1.1.3-5. Additional Band Class 6 Transmitter Spurious Emission Limits**

<b>Measurement Frequency</b>	<b>Applies to Multiple Carriers</b>	<b>Emission Limit</b>	<b>When Coverage Overlaps With</b>
1884.5 to 1919.6 MHz	No	-41 dBm / 300 kHz	PHS
876 to 915 MHz	No	-98 dBm / 100 kHz (co-located only) -61 dBm / 100 kHz (non-co-located)	GSM 900
921 to 960 MHz	Yes	-57 dBm / 100 kHz	GSM 900
1710 to 1785 MHz	No	-98 dBm / 100 kHz (co-located only) -61 dBm / 100 kHz (non-co-located)	DCS 1800
1805 to 1880 MHz	Yes	-47 dBm / 100 kHz	DCS 1800
1900 to 1920 MHz and 2010 to 2025 MHz	No	- 86dBm / 1 MHz (co-located only)	UTRA-TDD
1900 to 1920 MHz and 2010 to 2025 MHz	Yes	-52 dBm / 1 MHz	UTRA-TDD
1920 to 1980 MHz	No	- 86dBm / 1 MHz	Always

**Table 4.4.1.1.3-6. Additional Band Class 10 Transmitter Spurious Emission Limits for North American Operation**

<b>Measurement Frequency</b>	<b>Emission Limit</b>
854.75 to 861 MHz	-40 dBm / 30 kHz
866 to 869 MHz	-40 dBm / 30 kHz

Note: The Band Class 10 spurious emissions limit is designed to allow marginal co-existence with North American PMRS 800 MHz Public Safety services and is far tighter than the CFR 47 Part 90.691(a)(2) requirement.

Current region-specific radio regulation rules shall also apply.

#### 4.4.1.2 Pico Cell Base Station and Femto Cell

##### 4.4.1.2.1 Definition

Conducted spurious emissions are emissions at frequencies that are outside the assigned CDMA Channel, measured at the base station RF output port.

1 4.4.1.2.2 Method of Measurement

- 2 1. Connect a spectrum analyzer (or other suitable test equipment) to each base  
3 station RF output port, using an attenuator or directional coupler if necessary.
- 4 2. For each band class that the base station supports, configure the base station to  
5 operate in that band class and perform steps 3 through 11.
- 6 3. Configure the base station to transmit a single carrier and perform steps 4 through  
7 6.
- 8 4. Set the base station to transmit a signal modulated with a combination of code  
9 channels as stated in 6.5.2. Total mean power at the RF output port shall be the  
10 maximum mean output power as specified by the manufacturer.
- 11 5. Measure the power level at the carrier frequency.
- 12 6. Measure the mean spurious emission levels. Integration measurement techniques  
13 of ten or more subintervals shall be used for measurement bandwidths of 100 kHz  
14 and greater to minimize errors induced by spectrum analyzer filter response.
- 15 7. If the base station supports two carriers (two cdma2000® 1x carriers<sup>21</sup> or one  
16 cdma2000 1x and one cdma2000 high data rate packet carrier) through a single  
17 RF output port with a carrier-to-carrier spacing of 1.23 MHz (Band Class 0) or 1.25  
18 MHz (all other band classes), configure the base station to transmit two adjacent  
19 carriers and repeat step 11 for the following three sub-configurations:  
20 Let BW be the bandwidth of operation as specified by the manufacturer. This  
21 bandwidth can be smaller or equal to the bandwidth of the band class under test.

22 Let F\_high\_test = Center frequency of the highest carrier under test.

23 Let F\_low\_test = Center frequency of the lower carrier under test.

24 Let F\_high = Center frequency of the highest carrier within the bandwidth of  
25 operation.

26 Let F\_low = Center frequency of the lowest carrier within the bandwidth of  
27 operation.

28 The test shall be performed with each of the three sub-configurations:

29 (i)  $F_{low\_test} = F_{low}$ ,

30 (ii)  $F_{high\_test} = F_{high}$ ,

31 (iii)  $|(F_{high\_test} + F_{low\_test})/2 - (F_{high} + F_{low})/2|$  is as small as possible  
32 after taking into consideration the granularity of the channel spacing applicable in  
33 the bandwidth under consideration.

---

cdma2000® is the trademark for the technical nomenclature for certain specifications and standards of the Organizational Partners (OPs) of 3GPP2. Geographically (and as of the date of publication), cdma2000® is a registered trademark of the Telecommunications Industry Association (TIA-USA) in the United States.

<sup>21</sup> For example, one cdma2000 1x carrier and one cdma2000 1x beacon carrier.

- 1       8. If the base station supports two carriers through a single RF output port with a  
2 carrier-to-carrier spacing of greater than 1.23 MHz (Band Class 0) or 1.25 MHz (all  
3 other band classes), configure the base station to transmit two non-adjacent  
4 carriers with carrier-to-carrier spacing as per the manufacturer specifications and  
5 repeat step 12 for each of the three sub-configurations described in step 7.
- 6       9. If the base station supports three contiguous carriers (a combination of cdma2000  
7 1x carriers and cdma2000 high rate packed data carriers<sup>22</sup>) through a single RF  
8 output port, configure the base station to transmit contiguous with one another  
9 and repeat step 11 for each of the three sub-configurations described in step 7.
- 10      10. If the base station supports three non-contiguous carriers through a single RF  
11 output port, configure the base station to transmit these three non-contiguous  
12 carriers, where the spacing between the carriers is chosen as per the manufacture  
13 specification, and repeat step 12 for each of the three sub-configurations described  
14 in step 7.
- 15      11. For multiple-carrier tests with adjacent carriers, set up the base station as follows  
16 and perform step 13.

17           Set the base station to transmit multiple signals modulated with a combination of  
18 Pilot, Sync, Paging, and Traffic Channels as stated in 6.5.2. If a cdma2000 high  
19 rate data packet carrier (s) is tested simultaneously along with cdma2000 1x  
20 carrier (s), this carrier shall be operated in the continuous data mode specified in  
21 Section 4.4.1 Limitations on Spurious Emissions in C.S0032-C v1.0..

22           Each test shall be performed using maximum power settings specified by the  
23 manufacturer. If a manufacturer specifies several operation modes<sup>23</sup> with different  
24 maximum power settings for the adjacent carriers, then the test shall be executed  
25 using the following two operation modes:

- 26      1) A mode whose power settings result in maximum mean output power at the RF  
27 output port across all operation modes
- 28      2) If the base station supports two carriers, a mode satisfying 2(a) is executed. If the  
29 base station supports three carriers, a mode satisfying 2(b) is executed.
- 30           a. Let the double  $P = [p_1, p_2]$  denote the set of powers for the 2 carriers in  
31 order of increasing frequency, in a mode  $i$ . Let  $\text{Min}(P) = \min(p_1, p_2)$  and  
32  $\text{Max}(P) = \max(p_1, p_2)$ . When comparing 2 doubles  $P$  and  $P'$ , let  $P > P'$  if  
33  $\text{Min}(P) > \text{Min}(P')$ , or  
34  $\text{Min}(P) = \text{Min}(P')$  and  $\text{Max}(P) > \text{Max}(P')$ .  
35           Select the mode with the highest ranking based on the above

---

<sup>22</sup> For example, one cdma2000 1x carrier, one cdma2000 1x beacon carrier and one cdma2000 high rate packet data carrier.

<sup>23</sup> E.g. With two adjacent carriers, manufacturer may specify two operation modes with power levels (X1,Y1)dB and (X2,Y2)dB for the two carriers.

1 methodology. If multiple modes have the same ranking, choose a mode C  
2 = [c1,c2] among them such that  $c1 < c2$ .

3 b. Let the triple  $P=[p1,p2,p3]$  denote the set of powers for the 3 carriers in  
4 order of increasing frequency, in a mode i. Let  $Min(P) = \min(p1,p2,p3)$ ,  
5  $Max(P) = \max(p1,p2,p3)$ . Let  $Med(P)$  be the remaining element in the  
6 triple, other than  $Min$  and  $Max$ .

7 Now when comparing 2 triples P and P', let  $P > P'$  if  
8  $Min(P) > Min(P')$ , or

9  $Min(P)=Min(P')$  and  $Med(P) > Med(P')$  or

10  $Min(P)=Min(P')$ ,  $Med(P)=Med(P')$  and  $Max(P) > Max(P')$

11 Select the mode with the highest ranking based on the above  
12 methodology.

13 If multiple modes have the same ranking, choose a mode  $C = [c1,c2,c3]$   
14 among them such that  $c2 \geq c3 \geq c1$ .

15 12. For multiple-carrier tests with non-adjacent (non-contiguous) carriers, set up the  
16 base station as follows and perform step 13.

17 Set the base station to transmit multiple signals modulated with a combination of  
18 Pilot, Sync, Paging, and Traffic Channels as stated in 6.5.2. If a cdma2000 high  
19 rate data packet carrier (s) is tested simultaneously along with cdma2000 1x  
20 carrier (s), this carrier shall be operated in the continuous data mode specified in  
21 Section 4.4.1 Limitations on Spurious Emissions in C.S0032-v2.

22 Each test shall be performed using maximum power settings specified by the  
23 manufacturer. If a manufacturer specifies several operation modes with different  
24 maximum power settings for the non-adjacent carriers, then the tests shall be  
25 performed for any one operation mode.

26 13. For each radio configurations that the base station supports, measure the mean  
27 spurious emission levels with ten or more averages

#### 28 4.4.1.2.3 Minimum Standard

29 When transmitting in Band Class 0, 2, 3, 5, 7, 9, or 10 the spurious emissions shall be less  
30 than all of the limits specified in Table 4.4.1.2.3-1. When transmitting in Band Class 1, 4,  
31 6, 8, 14, or 15 the spurious emissions shall be less than all of the limits specified in Table  
32 4.4.1.2.3-2. When transmitting in Band Class 11 and 12, mean spurious emissions shall  
33 be less than the limits specified in Table 4.4.1.2.3-3. When transmitting in Band Class 3,  
34 mean spurious emissions for a single carrier shall be less than the limits specified in Table  
35 4.4.1.2.3-4. When transmitting in Band Class 6, mean spurious emissions shall also be  
36 less than the limits specified in Table 4.4.1.2.3-5. When transmitting in Band Class 10,  
37 mean spurious emissions shall also be less than the limits specified in Table 4.4.1.2.3-6.

38

**Table 4.4.1.2.3-1. Band Class 0, 2, 5, 7, 9, and 10 Transmitter Spurious Emission Limits**

<b>For <math> \Delta f </math> Within the Range</b>	<b>Applies to Multiple Carriers</b>	<b>Emission Limit</b>
750 kHz to 1.98 MHz	No	-45 dBc / 30 kHz
1.98 MHz to 4.00 MHz	No	-55 dBc / 30 kHz
1.98 MHz to 2.25 MHz (MC test only)	Yes	-25 dBm / 30 kHz
2.25 MHz to 4.00 MHz (MC test only)	Yes	-26 dBm / 1 MHz
3.25 MHz to 4.00 MHz (Band Class 7 only)	Yes	-46 dBm / 6.25 kHz
> 4.00 MHz	Yes	-36 dBm / 1 kHz;      9 kHz < f < 150 kHz -36 dBm / 10 kHz;      150 kHz < f < 30 MHz -46 dBm / 100 kHz;      30 MHz < f < 1 GHz -36 dBm / 1 MHz;      1 GHz < f < 12.5 GHz

Note 1: All frequencies in the measurement bandwidth shall satisfy the restrictions on  $|\Delta f|$ . The emissions requirements shall apply for all values of  $\Delta f$  regardless of whether the measurement frequency falls inside or outside of the band or block edge. For single-carrier testing,  $\Delta f$  = center frequency - closer measurement edge frequency (f). For multiple-carrier testing,  $\Delta f$  is defined for positive  $\Delta f$  as the closer measurement edge frequency (f) - center frequency of the highest carrier (F\_high\_test) and for negative  $\Delta f$  as the closer measurement edge frequency (f) - center frequency of the lowest carrier (F\_low\_test).

Compliance with the -46 dBm / 6.25 kHz limit is based on the use of measurement instrumentation such that the reading taken with any resolution bandwidth setting should be adjusted to indicate spectral power in a 6.25 kHz segment.

**Table 4.4.1.2.3-2. Band Class 1, 4, 6, 8, 13, 14, and 15 Transmitter Spurious Emission Limits**

<b>For <math> \Delta f </math> Within the Range</b>	<b>Applies to Multiple Carriers</b>	<b>Emission Limit</b>
885 kHz to 1.98 MHz	No	-45 dBc / 30 kHz
1.25 to 2.25 MHz (MC tests only)	Yes	-25 dBm / 30 kHz
1.98 MHz to 2.25 MHz	No	-55 dBc / 30 kHz
2.25 MHz to 4.00 MHz	Yes	-26 dBm / 1 MHz
> 4.00 MHz	Yes	-36 dBm / 1 kHz; 9 kHz < f < 150 kHz -36 dBm / 10 kHz; 150 kHz < f < 30 MHz -46 dBm / 100 kHz; 30 MHz < f < 1 GHz -36 dBm / 1 MHz; 1 GHz < f < 12.5 GHz

Note 1: All frequencies in the measurement bandwidth shall satisfy the restrictions on  $|\Delta f|$ . The emissions requirements shall apply for all values of  $\Delta f$  regardless of whether the measurement frequency falls inside or outside of the band or block edge. For single-carrier testing,  $\Delta f$  = center frequency - closer measurement edge frequency (f). For multiple-carrier testing,  $\Delta f$  is defined for positive  $\Delta f$  as the closer measurement edge frequency (f) - center frequency of the highest carrier (F\_high\_test) and for negative  $\Delta f$  as the closer measurement edge frequency (f) - center frequency of the lowest carrier (F\_low\_test).

1 **Table 4.4.1.2.3-3. Band Class 11 and 12 Transmitter Spurious Emission Limits**

<b>For <math> \Delta f </math> Within the Range</b>	<b>Applies to Multiple Carriers</b>	<b>Emission Limit</b>
750 to 885 KHz	No	$-45-15( \Delta f -750)/135$ dBc in 30 kHz
885 to 1125 KHz	No	$-60-5( \Delta f -885)/240$ dBc in 30 kHz
1.125 to 4 MHz	No	-65 dBc / 30kHz
> 4.00 MHz	Yes	$-36$ dBm / 1 kHz; 9 kHz < f < 150 kHz $-36$ dBm / 10 kHz; 150 kHz < f < 30 MHz $-46$ dBm/100 kHz; 30 MHz < f < 1 GHz $-36$ dBm / 1 MHz; 1 GHz < f < 12.75 GHz

Note 1: All frequencies in the measurement bandwidth shall satisfy the restrictions on  $|\Delta f|$  where  $\Delta f$  = center frequency - closer measurement edge frequency (f).  $\Delta f$  is positive offset from the highest valid CDMA channel in the band subclass or negative offset from the lowest valid CDMA channel in the band subclass. The emission limits for Band Class 11 and 12 (European PAMR bands) are designed to allow co-existence with incumbent services in Europe and are tighter than ITU Category B requirements.

2

**Table 4.4.1.2.3-4. Band Class 3 Transmitter Spurious Emission Limits**

Measurement Frequency	Applies to Multiple Carriers	For $ \Delta f $ Within the Range	Emission Limit
> 832 MHz and $\leq$ 834 MHz, > 838 MHz and $\leq$ 846 MHz, > 860 MHz and $\leq$ 895 MHz	No	$\geq$ 750kHz and $<$ 1.98MHz	-45 dBc / 30 kHz
	No	$\geq$ 1.98 MHz and $<$ 4.00 MHz	-36 dBm / 100 kHz
	No	$\geq$ 4.00 MHz	-46 dBm / 100 kHz
> 810 MHz and $\leq$ 860 MHz, except > 832 MHz and $\leq$ 834 MHz, > 838 MHz and $\leq$ 846 MHz	No	$<$ 1.98MHz	-16 dBm / 30 kHz
	No	$\geq$ 1.98 MHz and $<$ 4.00 MHz	-36 dBm / 100 kHz
	No	$\geq$ 4.00 MHz	-46 dBm / 100 kHz
$\leq$ 810 MHz and > 895 MHz	Yes	N/A	-36 dBm / 1 MHz

Note 1: All frequencies in the measurement bandwidth shall satisfy the restrictions on  $|\Delta f|$ . The emissions requirements shall apply for all values of  $\Delta f$  regardless of whether the measurement frequency falls inside or outside of the band or block edge. For single-carrier testing,  $\Delta f$  = center frequency - closer measurement edge frequency (f). For multiple-carrier testing,  $\Delta f$  is defined for positive  $\Delta f$  as the closer measurement edge frequency (f) - center frequency of the highest carrier (F\_high\_test) and for negative  $\Delta f$  as the closer measurement edge frequency (f) - center frequency of the lowest carrier (F\_low\_test). The upper and lower limits of the frequency measurement are currently 10 MHz and 3 GHz in Japan radio measurement documents.

2

3

**Table 4.4.1.2.3-5. Additional Band Class 6 Transmitter Spurious Emission Limits**

<b>Measurement Frequency</b>	<b>Applies to Multiple Carriers</b>	<b>Emission Limit</b>	<b>When Coverage Overlaps With</b>
1884.5 to 1919.6 MHz	No	-41 dBm / 300 kHz	PHS
824 to 849 MHz	No	-61 dBm / 100 kHz (non-co-located)	GSM850 CDMA850
869 to 894 MHz	Yes	-57 dBm / 100 kHz	GSM850 CDMA850
876 to 915 MHz	No	-61 dBm / 100 kHz (non-co-located)	GSM 900
921 to 960 MHz	Yes	-57 dBm / 100 kHz	GSM 900
1710 to 1785 MHz	No	-98 dBm / 100 kHz (co-located only) -61 dBm / 100 kHz (non-co-located)	DCS 1800
1805 to 1880 MHz	Yes	-47 dBm / 100 kHz	DCS 1800
1900 to 1920 MHz and 2010 to 2025 MHz	Yes	-52 dBm / 1 MHz	UTRA-TDD
1920 to 1980 MHz	No	- 86dBm / 1 MHz	Always

**Table 4.4.1.2.3-6. Additional Band Class 10 Transmitter Spurious Emission Limits for North American Operation**

<b>Measurement Frequency</b>	<b>Emission Limit</b>
854.75 to 861 MHz	-50 dBm / 30 kHz
866 to 869 MHz	-50 dBm / 30 kHz

Note: The Band Class 10 spurious emissions limit is designed to allow marginal co-existence with North American PMRS 800 MHz Public Safety services and is far tighter than the CFR 47 Part 90.691(a)(2) requirement.

Current region-specific radio regulation rules shall also apply.

#### 4.4.2 Radiated Spurious Emissions

Current region-specific radio regulation rules shall apply.

1 For example, a Band Class 7 base station operating under US regional requirements shall  
2 limit radiated spurious emissions to less than  $-70$  dBW/MHz EIRP in the GPS band from  
3 1559 to 1610 MHz.

#### 4 4.4.3 Inter-Base Station Transmitter Intermodulation

5 This test shall not apply to Femto Cells.

##### 6 4.4.3.1 Definition

7 Inter-base station transmitter intermodulation occurs when an external signal source is  
8 introduced to the antenna connector of the base station. This test verifies that base station  
9 conducted spurious emissions are still met with the presence of the interfering source.

##### 10 4.4.3.2 Method of Measurement

- 11 1. Connect a spectrum analyzer (or other suitable test equipment) and the external  
12 base station to the base station RF output port, using attenuators or directional  
13 couplers if necessary as shown in Figure 6.5.1-9.
- 14 2. For each band class that the base station supports, configure the base station to  
15 operate in that band class and perform steps 3 through 6.
- 16 3. Set the base station under test to transmit a signal modulated with a combination  
17 of Pilot, Sync, Paging, and Traffic Channels as stated in 6.5.2. Total power at the  
18 RF output port shall be the maximum power as specified by the manufacturer.
- 19 4. Set the second base station to transmit a signal modulated with a combination of  
20 Pilot, Sync, Paging, and Traffic Channels as stated in 6.5.2 with a total power that  
21 is 30 dB less than the power of the other base station with an offset of 1.25 MHz  
22 between the center of the CDMA center frequencies for Spreading Rate 1 or 3.75  
23 MHz between the center of the CDMA center frequencies for Spreading Rate 3.
- 24 5. Measure the power level at the carrier frequency.
- 25 6. Measure the spurious emission level at the image of the base station transmitter  
26 and the interference source. The image is centered at a frequency of 2 times the  
27 center frequency of the base station under test minus the center frequency of the  
28 second base station. The bandwidth of the image is the same as the bandwidth of  
29 the RC in effect.

##### 30 4.4.3.3 Minimum Standard

31 The base station shall meet the conducted spurious emission requirements in 4.4.1 that  
32 apply to the image.

##### 33 4.4.4 Occupied Bandwidth

34 This test applies to Band Classes 3 and 6 only.

1 4.4.1.1 Definition

2 The occupied bandwidth is defined as the frequency range, whereby the power of emissions  
3 averaged over the frequency above and under the edge frequency are 0.5% each of the total  
4 radiation power of a modulated carrier.

5 4.4.1.2 Method of Measurement

- 6 1. Connect the spectrum analyzer (or other suitable test equipment) to the base  
7 station RF output port using an attenuator.
- 8 2. Set the base station to transmit a signal modulated with a combination of Pilot,  
9 Sync, Paging, and Traffic Channels as described in 6.5.2. Total power at the RF  
10 output port shall be the normal power as specified by the manufacturer.
- 11 3. Set the resolution bandwidth of the spectrum analyzer to 30 kHz. The value of the  
12 occupied bandwidth is calculated by an external or internal computer by summing  
13 all samples stored as "total power".

14 4.4.1.3 Minimum Standard

15 The occupied bandwidth shall not exceed 1.48MHz for Spreading Rate 1 and 4.6MHz for  
16 Spreading Rate 3 (Band Class 6 only).

17

18

## 5 CDMA GENERAL REQUIREMENTS

### 5.1 Temperature and Power Supply Voltage

#### 5.1.1 Definition

The temperature and voltage ranges denote the ranges of ambient temperature and power supply input voltages over which the base station will operate and meet the requirements of this Standard. The ambient temperature is the average temperature of the air surrounding the base station equipment. The power supply voltage is the voltage applied at the input terminals of the base station equipment. The manufacturer is to specify the temperature range and the power supply voltage over which the equipment is to operate.

#### 5.1.2 Method of Measurement

The base station equipment shall be installed in its normal configuration (i.e., in its normal cabinet or rack mounting arrangement with all normally supplied covers installed) and placed in a temperature chamber. Optionally, the equipment containing the frequency determining element(s) may be placed in the temperature chamber if the frequency stability is to be maintained over a different temperature from that specified for the rest of the base-station equipment.

The temperature chamber shall be stabilized at the manufacturer's highest specified operating temperature and then shall be operated in accordance with the standard duty cycle test conditions specified in Section 6, and over the power supply input voltage range specified by the manufacturer. With the base station equipment operating, the temperature is to be maintained at the specified test temperature without forced circulation of air from the temperature chamber being directly applied to the base station equipment.

During the entire duty cycle, the transmitter frequency accuracy, timing reference, output power, and waveform quality shall be measured as specified in Section 4.

Turn the base station equipment off, stabilize the equipment in the chamber at room temperature, and repeat the above measurements after a 15-minute standby warm up period.

Turn the base station equipment off, stabilize the equipment in the chamber at the coldest operating temperature specified by the manufacturer, and repeat the above measurements above after a 15-minute standby warm up period.

For transmitter frequency stability measurements, the above procedure shall be repeated every 10°C over the operating temperature range specified by the manufacturer. The equipment shall be allowed to stabilize at each step before a frequency measurement is made.

#### 5.1.3 Minimum Standard

Over the ambient temperature and power supply ranges specified by the manufacturer, the operation of the base station equipment shall conform to the limits shown in Table 5.1.3-1.

**Table 5.1.3-1. Environmental Test Limits**

<b>Parameter</b>	<b>Limit</b>	<b>Reference</b>
Frequency Tolerance	$\pm 0.05$ ppm or $\pm 0.10$ ppm	4.1.2
Time Reference	$\pm 10$ $\mu$ s	4.2.1.1
Pilot Waveform Quality	$\rho > 0.912$	4.2.2
RF Power Output Variation	+2 dB, -4 dB	4.3.1

## 5.2 High Humidity

### 5.2.1 Definition

The term "high humidity" denotes the relative humidity at which the base station will operate with no more than a specified amount of degradation in performance.

### 5.2.2 Method of Measurement

The base station equipment, after having been adjusted for normal operation under standard test conditions, shall be placed, inoperative, in a humidity chamber with the humidity maintained at 0.024 gm H<sub>2</sub>O/gm Dry Air at 50°C (40% relative humidity) for a period of not less than eight hours. While in the chamber and at the end of this period, the base station transmitting equipment shall be tested for frequency accuracy, timing reference, output power, and waveform quality. No readjustment of the base station equipment shall be allowed during this test.

### 5.2.3 Minimum Standard

Under the above humidity conditions, the operation of the base station equipment shall conform to the limits specified in Table 5.1.3-1.

## 5.3 AC Power Line Conducted Emissions

### 5.3.1 Definition

AC power line conducted emissions tests shall be performed on all equipment that directly connects to the public utility power line. For equipment that receives power from a device that is directly connected to the public utility power line (such as a DC power supply), the conducted emissions tests shall be performed on the power supply device, with the equipment under test connected, to insure that the supply continues to meet the current emissions standards. AC power line conducted emissions tests are not required for equipment that contains an internal power source or battery supply with no means for connection to the public utility power line.

1 5.3.2 Method of Measurement

2 The conducted measurement procedures described in 4.4.1 shall be used for measuring  
3 conducted spurious emissions.

4 5.3.3 Minimum Standard

5 The radio frequency voltage, as measured in 5.3.2, shall not exceed 1 mV for frequencies  
6 between 450 and 1705 kHz and shall not exceed 3 mV for frequencies between 1.705 and  
7 30 MHz.

8

- 1 This page intentionally left blank.

## 6 CDMA STANDARD TEST CONDITIONS

### 6.1 Standard Equipment

#### 6.1.1 Basic Equipment

The equipment shall be assembled and any necessary adjustments shall be made in accordance with the manufacturer's instructions for the mode of operation required. When alternative modes are available, the equipment shall be assembled and adjusted in accordance with the relevant instructions. A complete series of measurements shall be made for each mode of operation.

#### 6.1.2 Associated Equipment

The base station equipment may include associated equipment during tests if the associated equipment is normally used in the operation of the equipment under test. This would include power supplies, cabinets, antenna couplers, and receiver multi-couplers.

### 6.2 Standard Environmental Test Conditions

Measurements under standard atmospheric conditions shall be carried out under any combination of the following conditions:

Temperature: +15 °C to +35 °C

Relative Humidity: 45% to 75%

Air Pressure: 86,000 to 106,000 Pa (860 to 1060 mbar)

If desired, the results of the measurements can be corrected by calculation to the standard reference temperature of 25°C and the standard reference air pressure of 101,300 Pa (1013 mbar).

### 6.3 Standard Conditions for the Primary Power Supply

#### 6.3.1 General

The standard test voltages shall be those specified by the manufacturer as minimum, normal, and maximum operating values. The voltage shall not deviate from the stated values by more than  $\pm 2\%$  during a series of measurements carried out as part of one test on the same equipment.

#### 6.3.2 Standard DC Test Voltage from Accumulator Batteries

The standard (or nominal) DC test voltage battery specified by the manufacturer shall be equal to the standard test voltage of the type of accumulator to be used multiplied by the number of cells minus an average DC power cable loss value that the manufacturer determines as being typical (or applicable) for a given installation. Since accumulator batteries may or may not be under charge and, in fact, may be in a state of discharge when the equipment is being operated, the manufacturer shall also test the equipment at anticipated voltage extremes above and below the standard voltage. The test voltages shall

1 not deviate from the stated values by more than  $\pm 2\%$  (nominal float voltage) during a series  
2 of measurements carried out as part of one test on the same equipment.

### 3 6.3.3 Standard AC Voltage and Frequency

4 For equipment that operates from the AC mains, the standard AC test voltage shall be  
5 equal to the nominal voltage specified by the manufacturer. If the equipment is provided  
6 with different input taps, the one designated “nominal” shall be used. The standard test  
7 frequency and the test voltage shall not deviate from their nominal values by more than  
8  $\pm 2\%$ .

9 The equipment shall operate without degradation with input voltage variations of up to  
10  $\pm 10\%$  and shall maintain its specified transmitter frequency stability for input voltage  
11 variations of up to  $\pm 15\%$ . The frequency range over which the equipment is to operate shall  
12 be specified by the manufacturer.

## 13 6.4 Standard Test Equipment

### 14 6.4.1 Channel Simulator

15 The channel simulator shall support the following channel model parameters:

- 16 • All paths are independently faded.
- 17 • The fading is Rayleigh. The probability distribution function of power,  $F(P)$ , is

$$18 \quad F(P) = \begin{cases} 1 - e^{-P/P_{ave}}, P > 0 \\ 0, P \leq 0 \end{cases}$$

19 where  $P$  is the signal power level and  $P_{ave}$  is the mean power level.

- 20 • The level crossing rate,  $L(P)$  is

$$21 \quad L(P) = \begin{cases} \sqrt{2\pi P/P_{ave}} \cdot f_d \cdot e^{-P/P_{ave}}, P > 0 \\ 0, P \leq 0 \end{cases}$$

22 where  $f_d$  is the Doppler frequency offset associated with the simulated vehicle speed  
23 given by

$$24 \quad f_d = \left(\frac{v}{c}\right) f_c$$

25  $f_c$  is the carrier frequency,  $v$  is the vehicle speed, and  $c$  is the speed of light in a  
26 vacuum.

- 1 • The power spectral density,  $S(f)$ , is

$$2 \quad S(f) = \left\{ \begin{array}{l} \frac{1}{\sqrt{1 - \left(\frac{f - f_c}{f_d}\right)^2}}, f_c - f_d \leq f \leq f_c + f_d \\ 0, \text{ otherwise} \end{array} \right\}$$

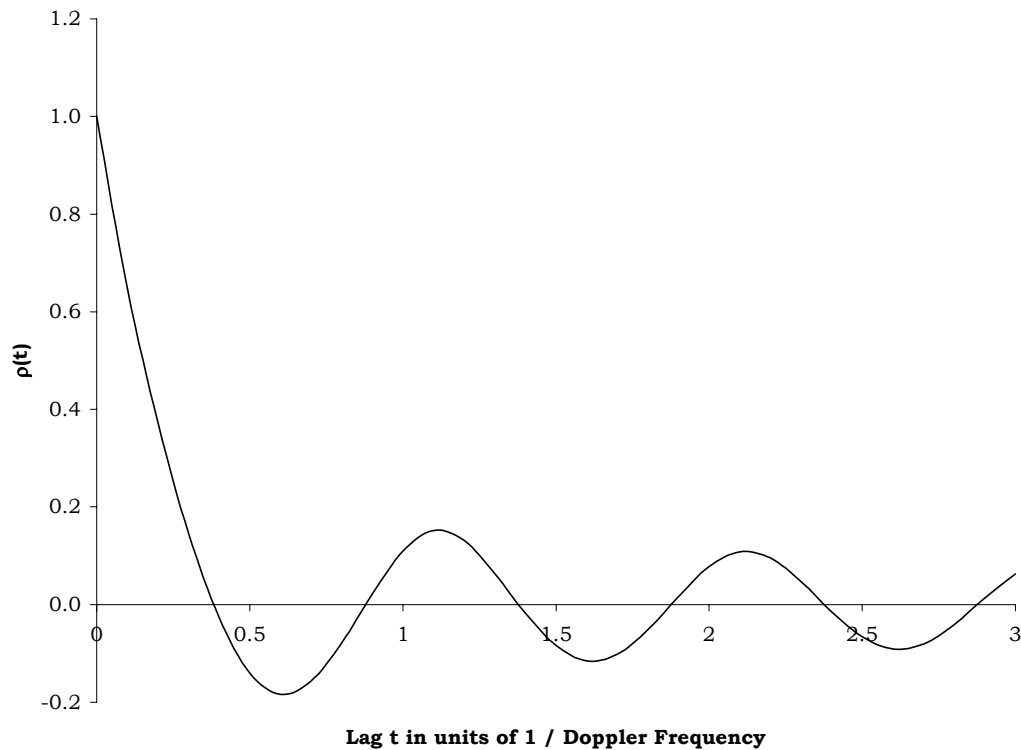
- 3 • The autocorrelation coefficient of the unwrapped phase<sup>24</sup>,  $\rho(t)$ , is

$$4 \quad \rho(t) = \frac{3}{2\pi} \sin^{-1}[J_0(2\pi f_d t)] + 6 \left\{ \frac{1}{2\pi} \sin^{-1}[J_0(2\pi f_d t)] \right\}^2 - \frac{3}{4\pi^2} \sum_{n=1}^{\infty} \frac{[J_0(2\pi f_d t)]^{2n}}{n^2}$$

5 where  $J_0(\ )$  is a zero-order Bessel function of the first kind.

6 This autocorrelation coefficient is shown in Figure 6.4.1-1.

7



8

9 **Figure 6.4.1-1. Autocorrelation Coefficient of the Phase**

10

---

<sup>24</sup>The term “unwrapped” refers to the continuous nature of the phase, that is, with no discontinuities of  $2\pi$ .

The following standard conditions and tolerances on the channel model parameters shall be supported by the channel simulator:

- Vehicle Speed,  $v$ , as shown in Table 6.4.1-1

The tolerance on Doppler shall be  $\pm 5\%$ .

- Power distribution function,  $F(P)$

1. The tolerance shall be within  $\pm 1$  dB of calculated, for power levels from 10 dB above to 20 dB below the mean power level.

2. The tolerance shall be within  $\pm 5$  dB of calculated, for power levels from 20 dB below to 30 dB below the mean power level.

- Level crossing rate,  $L(P)$

The tolerance shall be within  $\pm 10\%$  of calculated, for power levels from 3 dB above to 30 dB below the mean power level.

- Measured power spectral density,  $S(f)$ , around the carrier,  $f_c$

1. At frequency offsets  $|f-f_c|=f_d$ , the maximum power spectral density  $S(f)$  shall exceed  $S(f_c)$  by at least 6 dB.

2. For frequency offsets  $|f-f_c|>2f_d$ , the maximum power spectral density  $S(f)$  shall be less than  $S(f_c)$  by at least 30 dB.

- Simulated Doppler frequency,  $f_d$ , shall be computed from the measured  $S(f)$  as

$$f_d = \left[ \frac{2 \int (f - f_c)^2 S(f) df}{\int S(f) df} \right]^{1/2}$$

- Measured autocorrelation coefficient of the unwrapped phase,  $\rho(t)$

1. At a lag of  $0.05/f_d$  shall be  $0.8 \pm 0.1$ .

2. At a lag of  $0.15/f_d$  shall be  $0.5 \pm 0.1$ .

**Table 6.4.1-1. Standard Channel Simulator Configurations**

Channel Simulator Configuration	1	2	3	4
Vehicle Speed [km/h]	3	8	30	100
Number of Paths	1	2	1	3
Path 2 Power (Relative to Path 1) [dB]	N/A	0	N/A	0
Path 3 Power (Relative to Path 1) [dB]	N/A	N/A	N/A	-3
Delay from Path 1 to Input [ $\mu$ s]	0	0	0	0
Delay from Path 2 to Input [ $\mu$ s]	N/A	2.0	N/A	2.0
Delay from Path 3 to Input [ $\mu$ s]	N/A	N/A	N/A	14.5

## 1 6.4.2 Waveform Quality Measurement Equipment

### 2 6.4.2.1 Rho Meter

3 Equipment capable of performing waveform cross-correlation shall be used for the  
4 measurement of forward link frequency tolerance, pilot time tolerance, and waveform  
5 compatibility.

6 Various equipment implementations are possible. The equipment used shall provide results  
7 equivalent to those produced by equipment that use the following algorithms:

8 The ideal transmitter signal is given as

$$9 \quad s(t) = \sum_i R_i(t) e^{j\omega_c t}$$

10 where

11  $\omega_c$  is the nominal carrier frequency of the signal,

12  $\text{Re}[s]$  denotes the real part of the complex number  $s$ .

13  $R_i(t)$  is the complex envelope of the ideal  $i_{\text{th}}$  code channel, given as

$$14 \quad R_i(t) = a_i \left[ \sum_k g(t - kT_c) \cos(\phi_{i,k}) + j \sum_k g(t - kT_c) \sin(\phi_{i,k}) \right]$$

15 where

16  $a_i$  is the amplitude of the  $i_{\text{th}}$  code channel,

17  $g(t)$  is the unit impulse response of the cascaded transmit filter and phase equalizer  
18 described in 3.1.3.1.14 of [3],

19  $\phi_{i,k}$  is the phase of the  $k_{\text{th}}$  chip for the  $i_{\text{th}}$  code channel, occurring at discrete time  
20  $t_k = kT_c$ .

21 Modulation accuracy is the ability of the transmitter to generate the ideal signal  $s(t)$ .

22 The actual transmitter signal is given by

$$23 \quad x(t) = \sum_i b_i [R_i(t + \tau_i) + E_i(t)] e^{-j[(\omega_c + \Delta\omega)(t + \tau_i) + \theta_i]}$$

24 where

25  $b_i$  is the amplitude of the actual signal relative to the ideal signal for the  $i_{\text{th}}$  code  
26 channel,

27  $\tau_i$  is the time offset of the actual signal relative to the ideal signal for the  $i_{\text{th}}$  code  
28 channel,

1  $\Delta\omega$  is the radian frequency offset of the signal,

2  $\theta_i$  is the phase offset of the actual signal relative to the ideal signal for the  $i_{th}$   
3 code channel, and

4  $E_i(t)$  is the complex envelope of the error (deviation from ideal) of the actual  
5 transmit signal for the  $i_{th}$  code channel.

6 Estimates of the radian frequency offset  $\Delta\omega=2\pi\Delta f$  and the time offset  $\tau_0$ , of the pilot shall be  
7 obtained to the accuracy specified below in Table 6.4.2.1-1. These estimates  $\Delta\hat{\omega}$ ,  $\hat{\tau}_0$ , and  
8  $\hat{\theta}_0$ , shall be used to compensate  $x(t)$  by introducing a time correction and a complex  
9 multiplicative factor to produce  $y(t)$ , a compensated version of  $x(t)$ :

$$10 \quad y(t) = x(t - \hat{\tau}_0) e^{j[(\omega_c + \Delta\hat{\omega})t + \hat{\theta}_0]}$$

11 The radian frequency offset  $\Delta\hat{\omega}$  is converted to hertz frequency offset by  $\Delta\hat{f} = \frac{\Delta\hat{\omega}}{2\pi}$ . The  
12 compensated signal,  $y(t)$ , shall be passed through a complementary filter to remove the  
13 inter-symbol interference (ISI) introduced by the transmit filter and by the transmit phase  
14 equalizer to yield an output  $z(t)$ . The overall impulse response of the filter chain resulting  
15 from cascading the complementary filter with the ideal transmit filter and equalizer shall  
16 approximately satisfy Nyquist's criterion for zero ISI. The Nyquist criterion shall be  
17 approximated by filter null levels at least 50 dB below the on-time response at the  
18 appropriate sample times. The noise bandwidth of the complementary low pass filter shall  
19 be less than 625 kHz.

20 The idealized output of the complementary filter is

$$21 \quad r(t) = \sum_i \tilde{R}_i(t)$$

22 where

$$23 \quad \tilde{R}_i(t_k) = a_i [\cos(\phi_{i,k}) + j \sin(\phi_{i,k})]$$

24 Modulation accuracy is measured by determining the fraction of power at the  
25 complementary filter output,  $z(t)$ , that correlates with  $\tilde{R}_0(t_k)$ , the compensated pilot signal.

26 The filter output is sampled at the ideal decision points when the transmitter is modulated  
27 only by the Pilot Channel (the  $0_{th}$  code channel). The waveform quality factor ( $\rho$ ) is defined

28 as

$$29 \quad \rho = \frac{\left| \sum_{k=1}^M Z_k \tilde{R}_{0,k}^* \right|^2}{\left\{ \sum_{k=1}^M |\tilde{R}_{0,k}|^2 \right\} \left\{ \sum_{k=1}^M |Z_k|^2 \right\}}$$

1 where  $Z_k = z[k]$  is the  $k_{th}$  sample of the output of the complementary filter, and  
 2  $\tilde{R}_{0,k} = \tilde{R}_0[k]$  is the corresponding sample of the ideal output of the complementary filter for  
 3 the Pilot Channel.

4 Modulation accuracy shall be measured by using the  $k$  complex-valued samples,  $z(t_k)$ , over  
 5 a time interval  $M$ , in chips, of at least one power control group and an integer multiple of  
 6 512 chips.

7 The accuracy of the waveform quality measurement equipment shall be as shown in Table  
 8 6.4.2.1-1.

9

10

**Table 6.4.2.1-1. Accuracy of Waveform Quality Measurement Equipment**

Parameter	Symbol	Accuracy Requirement
Waveform Quality	$\rho$	$\pm 5 \times 10^{-4}$ from 0.90 to 1.0
Frequency Offset (exclusive of test equipment time base errors)	$\Delta f$	$\pm 10$ Hz
Pilot Time Alignment Offset	$\tau_0$	$\pm 135$ ns

11

#### 12 6.4.2.2 Code Domain Measurement Equipment

13 See 6.4.2.1 for definition of signal parameters. Code domain measurement equipment  
 14 estimates:

15 1. Walsh code domain power coefficients  $\rho_0, \rho_1, \rho_2, \dots, \rho_{L-1}$  (see below for definition).

16 2. Walsh code domain time offsets relative to pilot  $\Delta\tau_i$ , where

$$17 \quad \Delta\tau_i = \tau_i - \tau_0 .$$

18 3. Walsh code domain phase offsets relative to pilot  $\Delta\theta_i$ , where

$$19 \quad \Delta\theta_i = \theta_i - \theta_0 .$$

20 4. Frequency offset

$$21 \quad \Delta f = f_c - f_0$$

22 Code domain power is defined as the fraction of power in  $z(t_k)$  that correlates with each  
 23  $\tilde{R}_i(t_k)$  when the transmitter is modulated according to a known code symbol sequence.  
 24 The actual signal is compensated in frequency offset  $\Delta\omega$ , pilot time alignment offset  $\tau_0$ , and  
 25 pilot phase  $\theta_0$ .

26 Code domain power coefficients  $\rho_i$  are defined as

$$\rho_i = \frac{\sum_{j=1}^N \left| \sum_{k=1}^{64} Z_{j,k} \tilde{R}_{i,j,k}^* \right|^2}{\left\{ \sum_{k=1}^{64} \left| \tilde{R}_{i,j,k} \right|^2 \right\} \left\{ \sum_{j=1}^N \sum_{k=1}^{64} \left| Z_{j,k} \right|^2 \right\}}, \quad i = 0, 1, 2, \dots, L-1$$

where  $Z_k$  is defined in 6.4.2.1,  $L$  is the maximum Walsh function length,  $\tilde{R}_{i,j,k} = \tilde{R}_i[k]$  is the  $k$ th sample of the ideal output of the complementary filter for the  $i$ th code channel, and  $N$  is the measurement interval in units of the longest Walsh length, which shall be at least one power control group in length and an integer multiple of 512 chips.

The code domain time offsets  $\tau_i$  and phase offsets  $\theta_i$  shall be determined by creating the reference signal

$$\hat{R}_k = \sum_i R_i(t_k + \hat{\tau}_i) e^{-j[\Delta\hat{\omega}(t_k + \hat{\tau}_i) + \hat{\theta}_i]}$$

and finding the estimates  $\Delta\hat{\omega}$ ,  $\hat{\tau}_i$ ,  $\hat{a}_i$ , and  $\hat{\theta}_i$  to minimize the sum-square-error

$$\varepsilon^2 = \sum_{k=1}^N \left| Z_k - \hat{R}_k \right|^2$$

where  $Z_k = z(t_k)$  is the output of the complementary filter at the  $k$ th sample time.

The accuracy of the code domain measurement equipment shall be as shown in Table 6.4.2.2-1 for the nominal Base Station Test Model (refer to 6.5.2).

**Table 6.4.2.2-1. Accuracy of Code Domain Measurement Equipment**

Parameter	Symbol	Accuracy Requirement
Code domain power coefficients	$\rho_i$	$\pm 5 \times 10^{-4}$ from $5 \times 10^{-4}$ to 1.0
Frequency Offset (exclusive of test equipment time base errors)	$\Delta f$	$\pm 10$ Hz
Code domain time offset relative to pilot	$\Delta \tau_i$	$\pm 10$ ns
Code domain phase offset relative to pilot	$\Delta \theta_i$	$\pm 0.01$ radians

### 6.4.3 Mobile Station Simulator

The mobile station simulator shall be compliant with [3] and [4]. The mobile station simulator shall support Service Option 2, 9, and 55 [5] and Service Option 32 [6] and may support Service Option 54 [7].

It shall be possible to disable reverse link closed loop power control in the mobile station simulator. This includes reverse link closed loop power control commands sent on the Forward Power Control Subchannel and the Common Power Control Channel. When closed loop power control is disabled, it shall be possible to set the mobile station simulator transmit power to any fixed level with a resolution of  $\pm 0.1$  dB over the full dynamic range.

The mobile station simulator shall include a power control test program. The program function is to cycle the transmit power as shown in Figure 4.2.3.2-1. The transitions of output power shall be aligned with the power control group boundaries as defined in 6.1 of [3]. It shall also provide a timing reference signal aligned to the power cycles and it may provide the value of the power control bits received on the forward link. The duration of the high and low power period shall be at least 5 ms (4 power control groups).

The mobile station simulator shall have an ACLR of greater than 72 dB when operating with Spreading Rate 1 with Band Class 6. The mobile station simulator shall have an ACLR of greater than 66 dB when operating with Spreading Rate 3 with Band Class 6.

When testing Radio Configuration 3 through 6 (3.6), the Enhanced Access Channel (3.2), or the Reverse Common Control Channel (3.3), the mobile station simulator shall apply the nominal channel attribute gain table values specified in Section 2.1.2.3.3 of [3]. The mobile station simulator shall set all Reverse Link Attribute Adjustment Gain Table and Reverse Channel Adjustment Gain Table values to zero. The mobile station simulator shall set the RLGAIN\_TRAFFIC\_PILOT, RLGAIN\_SCH\_PILOT, RLGAIN\_CQICH\_PILOT, RLGAIN\_ACKCH\_PILOT and RLGAIN\_COMMON\_PILOT values to 0 dB.

### 6.4.4 AWGN Generator

The AWGN generator shall meet the following minimum performance requirements:

- Minimum Bandwidth: 1.8 MHz for Spreading Rate 1 or 5.4 MHz for Spreading Rate 3
- Frequency Ranges: For each band class under test, the AWGN generator must tune over the range of transmit and receive frequencies for that band class.
- Frequency Resolution: 1 kHz
- Output Accuracy:  $\pm 2$  dB for outputs  $\geq -80$  dBm
- Output Settability: 0.1 dB
- Output Range: -20 to -95 dBm
- Gain Flatness: 1.0 dB over the minimum bandwidth.
- The AWGN generators shall be uncorrelated to the ideal transmitter signal and to each other.

1 6.4.5 CW Generator

- 2 • Output Frequency Range: Tunable over applicable range of radio frequencies for  
3 band class under test. For Band Class 6, the upper limit shall be 12.75 GHz to  
4 support the receiver blocking spec.
- 5 • Frequency Accuracy:  $\pm 1$  ppm.
- 6 • Frequency Resolution: 100 Hz.
- 7 • Output Range: -50 dBm to -10 dBm, and off.
- 8 • Output Accuracy:  $\pm 1.0$  dB.
- 9 • Output Resolution: 0.1 dB.
- 10 • Output Phase Noise at -20 dBm Power:  
11 -149 dBc/Hz at a frequency of 1 GHz as measured at a 285 kHz offset (Band Groups  
12 450 and 800).  
13 -144 dBc/Hz at a frequency of 2 GHz as measured at a 655 kHz offset (Band Groups  
14 1900).

15 6.4.6 Spectrum Analyzer

16 The spectrum analyzer shall provide the following functionality:

- 17 • General purpose frequency domain measurements.
- 18 • Integrated channel power measurements for measurement bandwidths of 100 kHz  
19 and greater.
- 20 • Integrated channel power measurements (power spectral density in 1.23 MHz)

21 The spectrum analyzer shall meet the following minimum performance requirements:

- 22 • Frequency Range: Tunable over applicable range of radio frequencies.
- 23 • Frequency Resolution: 1 kHz.
- 24 • Frequency Accuracy:  $\pm 0.2$  ppm.
- 25 • Displayed Dynamic Range: 70 dB.
- 26 • Display Log Scale Fidelity:  $\pm 1$  dB over the above displayed dynamic range.
- 27 • Amplitude Measurement Range for signals from 10 MHz to either 2.6 GHz for Band  
28 Groups 450 and 800 or 6 GHz for Band Group 1900:

29 Power measured in 30 kHz Resolution Bandwidth: -90 to +20 dBm.

30 Integrated 1.23 MHz Channel Power: -70 to +47 dBm.

31 Note: The Standard RF Output Load described in 6.4.8 may be used to meet the  
32 high power end of these measurements.

- 33 • Absolute Amplitude Accuracy in the CDMA transmit and receive bands for integrated  
34 1.23 MHz channel power measurements:

- 1           ±1 dB over the range of -40 dBm to +20 dBm
- 2           ±1.3 dB over the range of -70 dBm to +20 dBm.
- 3           • Relative Flatness: ±1.5 dB over frequency range 10 MHz to either 2.6 GHz for Band
- 4           Groups 450 and 800 or 6 GHz for Band Group 1900.
- 5           • Resolution Bandwidth Filter: Synchronously tuned or Gaussian (at least 3 poles)
- 6           with 3 dB bandwidth selections of 1 MHz, 300 kHz, 100 kHz, and 30 kHz.
- 7           • Post Detection Video Filters: Selectable in decade steps from 100 Hz to at least 1
- 8           MHz.
- 9           • Detection Modes: Selectable to be either Peak or Sample.
- 10          • RF Input Impedance: Nominal 50 ohm

#### 11   6.4.7 Average Power Meter

12   The power meter shall provide the following functionality:

- 13          • Average power measurements.
- 14          • True RMS detection for both sinusoidal and non-sinusoidal signals
- 15          • Absolute power in linear (watt) and logarithmic (dBm) units.
- 16          • Relative (offset) power in dB and % units.
- 17          • Automatic calibration and zeroing.
- 18          • Averaging of multiple readings.

19   The power meter shall meet the following minimum performance requirements:

- 20          • Frequency Range: 10 MHz to either 1 GHz for Band Groups 450 and 800 or 2 GHz
- 21          for Band Group 1900.
- 22          • Power Range: -70 dBm (100 pW) to +47 dBm (50 W)

23          Different sensors may be required to optimally provide this power range. The RF

24          output load described in 6.4.8 may be used to meet the high power end of these

25          measurements.

- 26          • Absolute and Relative Power Accuracy: ±0.2 dB (5%)
- 27          Excludes sensor and source mismatch (VSWR) errors, zeroing errors (significant at
- 28          bottom end of sensor range), and power linearity errors (significant at top end of
- 29          sensor range).
- 30          • Power Measurement Resolution: Selectable 0.1 and 0.01 dB.
- 31          • Sensor VSWR: 1.15:1

#### 32   6.4.8 RF Output Load

33   The base station transmitter output shall be connected through suitable means to the

34   measurement equipment or mobile station simulator. The means shall be non-radiating

1 and capable of continuously dissipating the full transmitter output power. The VSWR seen  
2 by the transmitter over the 1.23 MHz band centered at the nominal transmit frequency  
3 under test shall be less than 1.1:1.

4 The base station transmitter signal may be terminated and sampled using a dummy load,  
5 attenuator, directional coupler, or combination thereof.

## 6 **6.5 Test Setups**

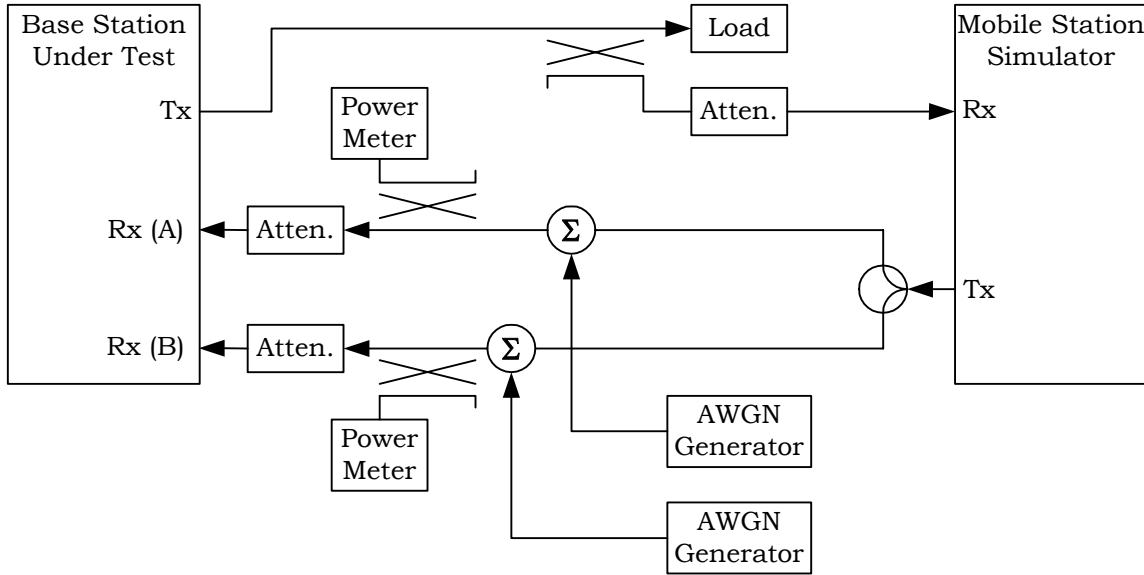
### 7 6.5.1 Functional System Setups

8 Figures 6.5.1-1 through 6.5.1-10 show the test setups used for base station testing. These  
9 are functional diagrams only. Actual test setups may differ provided the functionality  
10 remains the same.

11

12

1



2

3

4

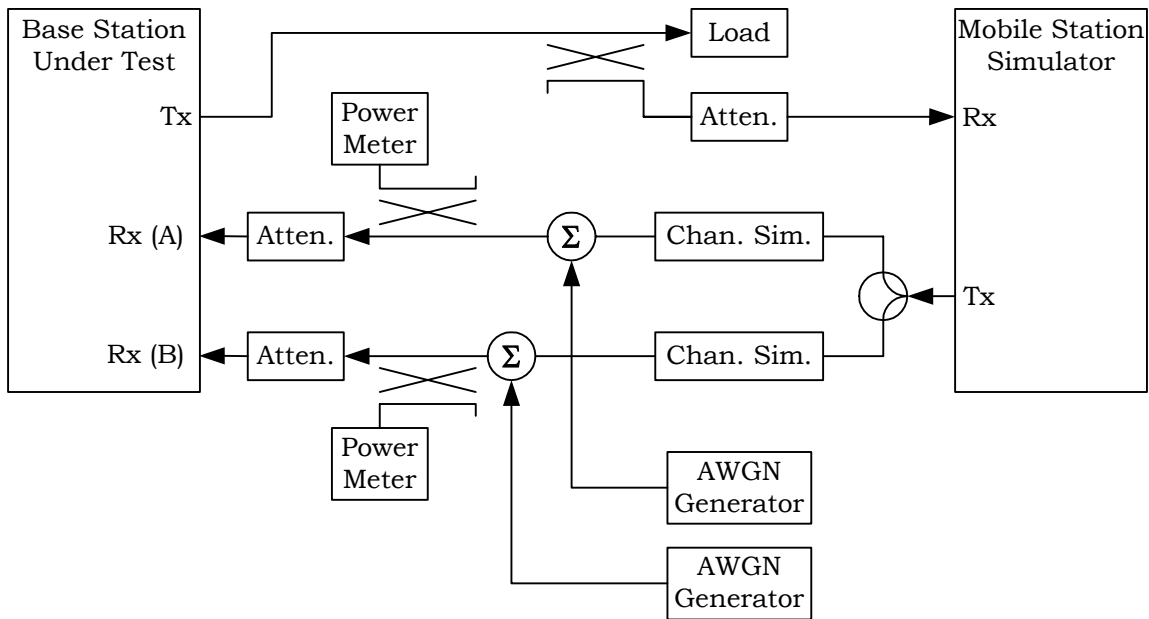
5

**Figure 6.5.1-1. Functional Setup for Base Station Additive White Gaussian Noise Demodulation Tests and Sensitivity Tests**

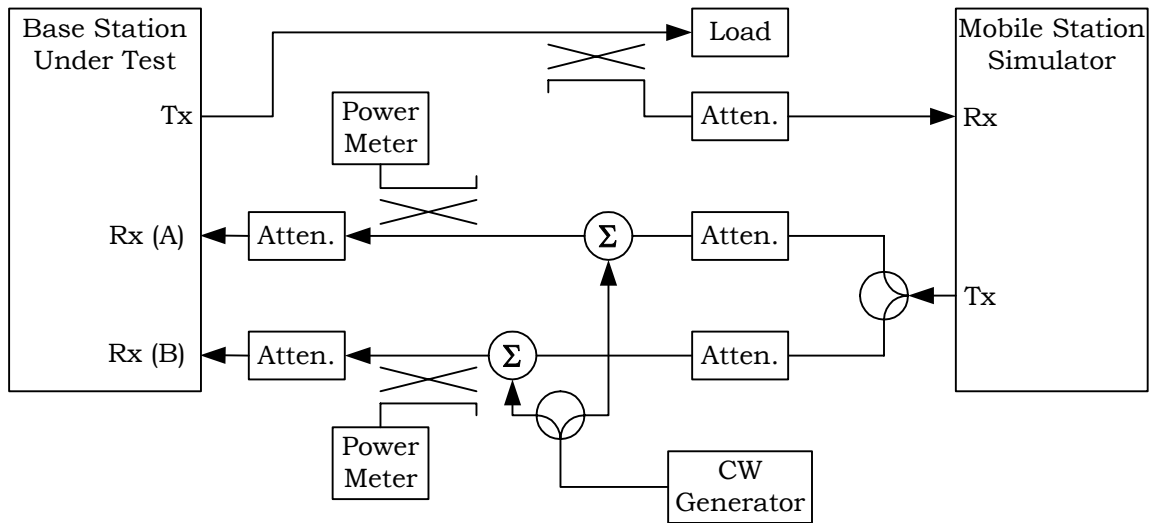
6

7

8

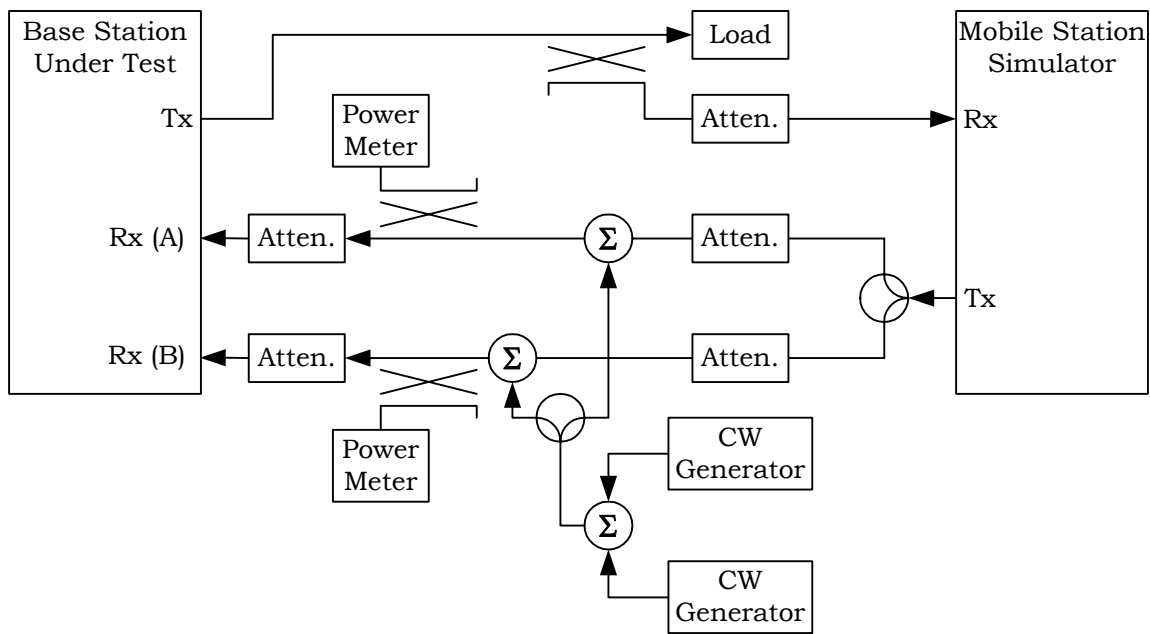


**Figure 6.5.1-2. Functional Setup for Base Station Multipath Fading Tests**



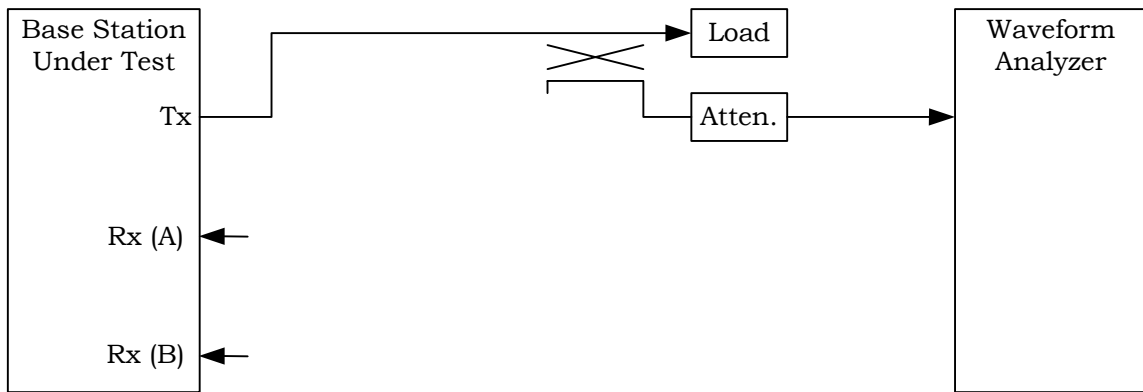
1  
2  
3

**Figure 6.5.1-3. Functional Setup for Base Station Desensitization and Blocking Tests**



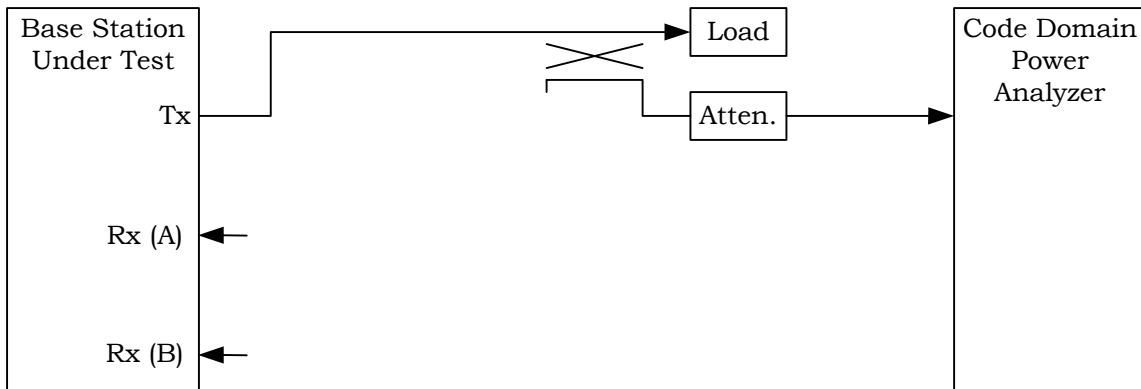
4  
5  
6  
7

**Figure 6.5.1-4. Functional Setup for Base Station Intermodulation Spurious Response Tests**



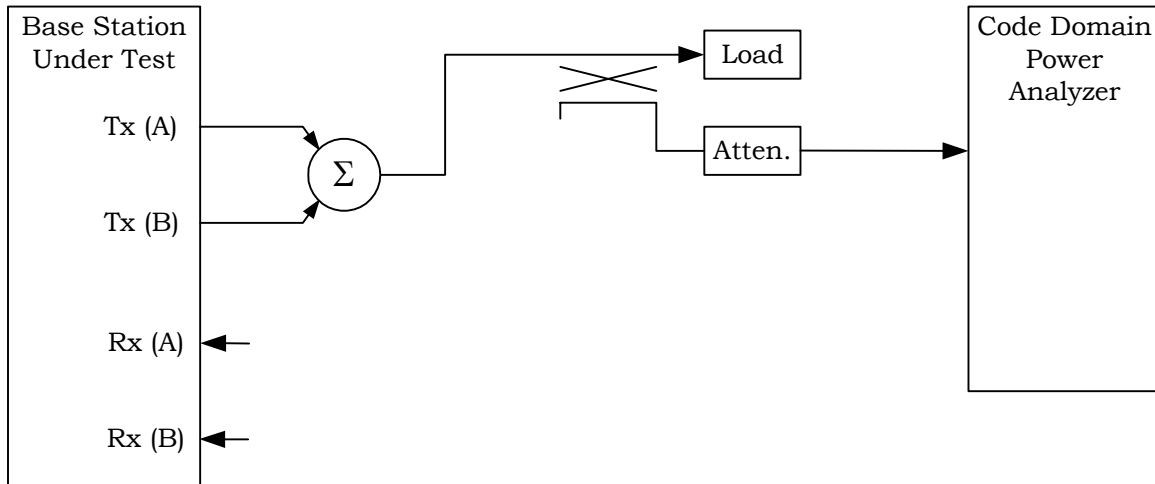
1  
2  
3

**Figure 6.5.1-5. Functional Setup for Waveform Quality Test**



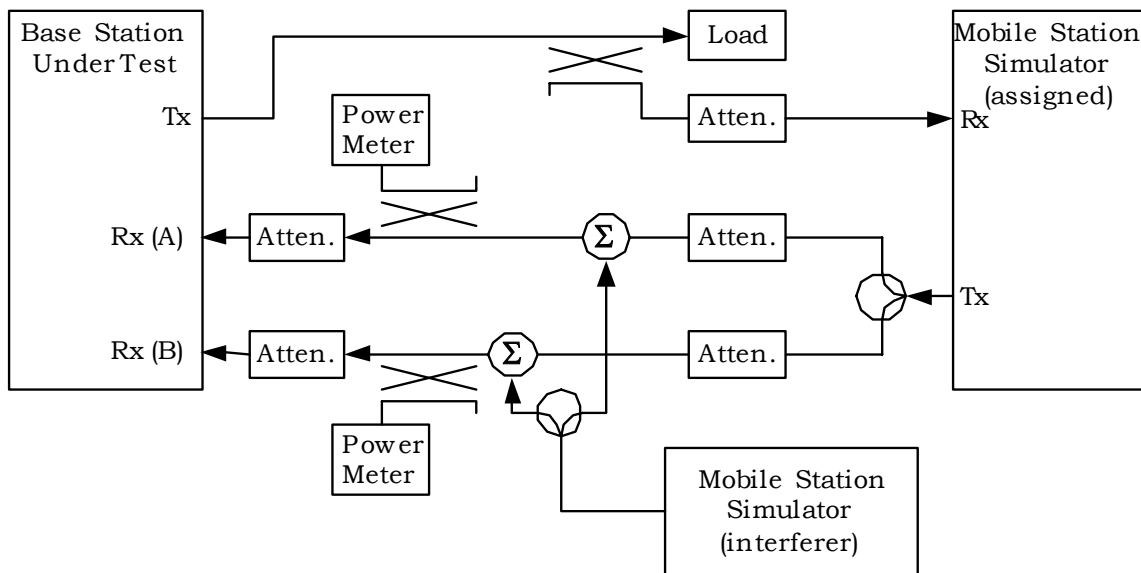
4  
5  
6  
7

**Figure 6.5.1-6. Functional Setup for Code Domain Power Test for Non-Transmit Diversity Configuration**



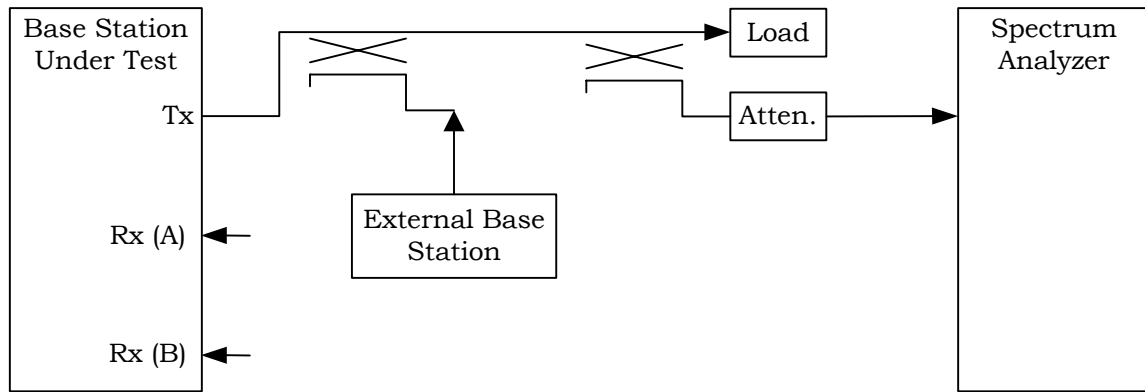
1  
2  
3  
4

**Figure 6.5.1-7. Functional Setup for Code Domain Power Test for Transmit Diversity Configuration**



5  
6  
7

**Figure 6.5.1-8. Functional Setup for Base Station ACS Tests**



1

2

**Figure 6.5.1-9. Functional Setup for Inter-Base Station Intermodulation Test**

3

4

#### 6.5.2 Test Model for Base Station

5

For those base station equipment tests that require multiple code channels be active simultaneously, the configuration shown in Table 6.5.2-1 or 6.5.2-3 should be used. Table 6.5.2-2 should be used for base station equipment tests for the transmit diversity that require multiple code channels be active simultaneously. If transmit diversity is enabled, the power on the Forward Pilot Channel and the Transmit Diversity Pilot Channel shall be the same and the power on the each traffic channel on the main and diversity path shall be the same.

6

7

8

9

10

11

12

For Tables 6.5.2-1, 6.5.2-2, and 6.5.2-3, the fraction of power noted for each traffic channel shall be inclusive of power control bits.

13

14

1 **Table 6.5.2-1. Radio Configuration 1 through 9 Base Station Test Model, Nominal for**  
 2 **Main Path**

<b>Channel Type</b>	<b>Number of Channels</b>	<b>Fraction of Power (linear)</b>	<b>Fraction of Power (dB)</b>	<b>Comments</b>
Forward Pilot	1	0.2000	-7.0	Code channel $W_0^{64}$
Sync	1	0.0471	-13.3	Code channel $W_{32}^{64}$ ; always 1/8 rate
Paging	1	0.1882	-7.3	Code channel $W_1^{64}$ ; full rate only
Traffic	M	0.5647/M	-2.48 - 10 log(M)	Variable code channel assignments; full rate only

For the Total Power (4.3.1) and Conducted Spurious Emissions tests (4.4.1), M shall be the lesser of 37 or the maximum number of Fundamental Traffic Channels supported by the base station for the radio configuration under test.

For all other tests, M shall be 6 or the maximum number of Fundamental Traffic Channels supported by the base station for the radio configuration under test.

For multiple-carrier Conducted Spurious Emissions tests (4.4.1) with cdma2000 1x beacon carrier, the entire power on this carrier shall be shared across pilot, sync and paging channels as specified below:

<b>Channel Type</b>	<b>Number of Channels</b>	<b>Fraction of Power (linear)</b>	<b>Fraction of Power (dB)</b>	<b>Comments</b>
Forward Pilot	1	0.4595	-3.38	Code channel $W_0^{64}$
Sync	1	0.1081	-9.66	Code channel $W_{32}^{64}$ ; always 1/8 rate
Paging	1	0.4324	-3.64	Code channel $W_1^{64}$ ; full rate only

**Table 6.5.2-2. Radio Configuration 1 through 9 Base Station Test Model, Nominal for Transmit Diversity Path**

Channel Type	Number of Channels	Fraction of Main Path Power (linear)	Fraction of Main Path Power (dB)	Comments
Transmit Diversity Pilot	1	0.2000	-7.0	Code channel $W_{16}^{128}$
Traffic	M	0.5647/M	-2.48 - 10 log(M)	Variable code channel assignments; full rate only

For the Total Power (4.3.1) and Conducted Spurious Emissions tests (4.4.1), M shall be the lesser of 37 or the maximum number of Fundamental Traffic Channels supported by the base station for the radio configuration under test.

For all other tests, M shall be 6.

**Table 6.5.2-3. Radio Configuration 10 Base Station Test Model)**

Channel Type	Number of Channels	Fraction of Power (linear)	Fraction of Power (dB)	Comments
Forward Pilot	1	0.1000	-10.0	Code channel $W_0^{64}$
Sync	1	0.0500	-13.0	Code channel $W_{32}^{64}$ ; always 1/8 rate
Paging	1	0.1000	-10.0	Code channel $W_1^{64}$ ; full rate only
Packet Data Control	1	0.1000	-10.0	Code channel $W_{33}^{64}$
Traffic	1	0.1000	-10.0	Variable code channel; full rate only
Packet Data	1	0.5500	-2.6	At the highest data rate supported by the base station

### 6.5.3 General Comments

The following comments apply to all CDMA tests:

1. Unless specified otherwise, test configurations should use the nominal base station parameter settings specified by the base station manufacturer.
2. Overhead message fields should be those needed for normal operation of the mobile station and the base station unless stated differently below or in a specific test.

Special field values of the *Enhanced Access Parameters Message*:

Field	Value (Decimal)
NUM_MODE_SELECTION_ENTRIES	0 (only one access mode specified)
ACCESS_MODE	0 (Basic Access Mode)
RLGAIN_COMMON_PILOT	0 (0 dB)
NUM_MODE_PARAM_REC	0 (only Basic Access Mode specific parameter records)
APPLICABLE_MODES	1 (parameters are for Basic Access Mode)
EACH_NOM_PWR	0 (0 dB)
EACH_INIT_PWR	0 (0 dB)
EACH_PWR_STEP	0 (0 dB)
EACH_NUM_STEP	4 (5 probes per sequence)
EACH_ACCESS_THRESH	63 (effectively disable pilot threshold detection)
EACH_SLOT_OFFSET1	0 (no offset)
EACH_SLOT_OFFSET2	0 (no offset)
NUM_EACH_BA	1 (one Enhanced Access Channel)
EACH_BA_RATES_SUPPORTED	0 (9600 bps, 20 ms frame size)

## 6.6 Standard Duty Cycle

The transmitter shall be capable of operating continuously at full rated power for a period of twenty-four (24) hours. The equipment shall operate with all specified transmitter and receiver performance parameters being met during and after the 24-hour period.

## 6.7 Frame Error Rate Measurement

The Reverse Common Control Channel FER is calculated as:

$$FER = 1 - \frac{\text{Number of RCCCH frames received correctly}}{\text{Number of RCCCH frames transmitted}}$$

The physical layer of [3] provides Reverse Traffic Channel frames at a multiplicity of rates. When demodulating the Reverse Fundamental Channel, receivers must determine both the transmitted rate of each frame, and its contents.

1 For purposes of this specification, a Reverse Traffic Channel frame error is defined as either  
 2 a rate determination or content error. The Reverse Traffic Channel FER is calculated for  
 3 active frames only and is calculated as:

$$4 \quad FER_X = 1 - \frac{\text{Number of active frames received correctly at rate X}}{\text{Number of active frames transmitted at rate X}}$$

5 The Loopback Service Option, Markov Service Option, and Test Data Service Option (see  
 6 1.3) provide a convenient means for measuring the packet error rate of one link, provided  
 7 the other link is operating at high  $E_b/N_0$ . During the base station Reverse Traffic Channel  
 8 demodulation performance tests signaling may be disabled, in which case the packet error  
 9 rate is identical to the Reverse Traffic Channel frame error rate.

10 The Reverse Channel Quality Indicator Channel FER is calculated for active frames only  
 11 and is calculated as:

$$12 \quad FER_X = 1 - \frac{\text{Number of active frames received correctly at rate X}}{\text{Number of active frames transmitted at rate X}}$$

13 where X is either 800 bits/s (differential C/I values) or 3200 bits/s (full C/I values).

14 The Reverse Acknowledgment Channel error rates, False Alarm Rate (FAR) and Missed  
 15 Detection Rate (MDR), are calculated as:

$$16 \quad FAR = \frac{\text{Number of ACK frames decoded when ACK was not sent}}{\text{Number of inactive frames} + \text{Number of active NAK frames transmitted}}$$

$$17 \quad MDR = 1 - \frac{\text{Number of ACK frames received correctly}}{\text{Number of active ACK frames transmitted}}$$

## 18 **6.8 Confidence Limits**

19 Some tests in this Standard include confidence limits. The requirement is stated in terms  
 20 of the confidence level with which the error rate of the equipment under test is known to be  
 21 below some specified maximum.

22 Error rate confidence testing typically requires  $E_b/N_0$  values above expected values.  
 23 Specific  $E_b/N_0$  values have been chosen to allow manufacturers to conduct tests in a  
 24 timely manner for the specified confidence levels.

25 Any reliable statistical procedure may be used to establish the confidence level. The tests  
 26 may be either single-sided or two-sided. They also may be either fixed length or variable  
 27 length. The procedure shall satisfy the following requirements:

- 28 • An established procedure shall be employed. It shall include:
  - 29 - Specification of minimum and maximum test length
  - 30 - Criteria for early termination
- 31 • Objective pass-fail criteria shall be established.
- 32 • Steps to be taken to rerun the test in case of a failure shall be specified.

1 Trial-to-trial correlations of errors, as may occur in frame error measurements in slow  
 2 fading scenarios, should be taken into account. In addition to statistical variations in  
 3 measurements, systematic errors due to test equipment tolerances and calibration should  
 4 be considered in interpretation of results.

5 An acceptable procedure is as follows. Assume independent Bernoulli trials, where the  
 6 outcome of each trial is classified as either 'error' or 'no error'. The specification error rate  
 7 limit is  $\lambda_{lim}$  and the required confidence level is C.

- 8 1. Choose a suitable test length in terms of a maximum number of errors,  $K_{max}$ . The  
 9 exact value is not critical, but must be large enough to ensure that compliant units  
 10 pass with very high probability. This probability depends on the design rate ratio  
 11  $\lambda/\lambda_{lim}$  between the design error rate and the specification error rate limit. Values of  
 12  $K_{max}$  in the range of 30-100 should be suitable based on the margins in this  
 13 Standard.
- 14 2. Carry out  $N_{max}$  or more trials under specified test conditions, where

$$15 \quad N_{max} = \frac{\chi^2(1-C, 2K_{max})}{2\lambda_{lim}}$$

16 and  $\chi^2(P, n)$  is the inverse  $\chi^2$ -distribution corresponding to probability P and n  
 17 degrees-of-freedom. Table 6.8-1 gives  $N_{max}$  versus the actual number of errors (K)  
 18 for C = 95% and representative  $\lambda_{lim}$ . Table 6.8-2 gives  $N_{max}$  versus the actual  
 19 number of errors(K) for C = 90% and representative  $\lambda_{lim}$ .

- 20 3. Compute the empirical error rate

$$21 \quad \lambda_N = \frac{K_N}{N}$$

22 and the empirical rate ratio  $\lambda_N/\lambda_{lim}$ , where  $K_N$  is the number of errors in the N  
 23 trials actually performed.

- 24 4. If the rate ratio is less than the confidence limit

$$25 \quad \lambda_N/\lambda_{lim} < \frac{2K_N}{\chi^2(1-C, 2K_N+2)}$$

26 or equivalently

$$27 \quad N > \frac{\chi^2(1-C, 2K_N+2)}{2\lambda_{lim}}$$

28 then the unit under test has passed; otherwise the unit has failed.

- 29 5. If the unit fails, repeat steps 2-4 twice more. If the unit passes both individual tests  
 30 then it passes overall; otherwise the unit has failed.

1 This procedure may be modified to permit early termination. A test may be performed at  
 2 every trial, or after a block of trials. Steps 3 and 4 are modified as follows:

3 3'. After each trial or block of trials compute the empirical error rate as

$$4 \quad \lambda_N = K_N / N$$

5 where  $K_N$  is the number of errors up to and including the current ( $N_{th}$ ) trial, and  
 6 the rate ratio  $\lambda_N / \lambda_{lim}$ .

7 4'. If after the  $N_{th}$  trial the rate ratio is less than the confidence limit

$$8 \quad \lambda_N / \lambda_{lim} < \frac{2K_N}{\chi^2(1-C, 2K_N + 2)}$$

9 or equivalently

$$10 \quad N > \frac{\chi^2(1-C, 2K_N + 2)}{2\lambda_{lim}}$$

11 then the unit under test has passed and the testing stops. If the number of trials  
 12 reaches  $N_{max}$  then the unit has failed and the testing stops.

13

1

**Table 6.8-1. Trial Count (N) Thresholds for 95% Confidence**

<b>K</b>	<b><math>\lambda_{lim}</math></b>			<b>General</b>
	<b>0.5%</b>	<b>1.0%</b>	<b>5.0%</b>	
0	599	300	60	$3.00/\lambda_{lim}$
1	599	300	60	$3.00/\lambda_{lim}$
2	949	474	95	$4.74/\lambda_{lim}$
3	1259	630	126	$6.30/\lambda_{lim}$
4	1551	775	155	$7.75/\lambda_{lim}$
5	1831	915	183	$9.15/\lambda_{lim}$
6	2103	1051	210	$10.51/\lambda_{lim}$
7	2368	1184	237	$11.84/\lambda_{lim}$
8	2630	1315	263	$13.15/\lambda_{lim}$
9	2887	1443	289	$14.43/\lambda_{lim}$
10	3141	1571	314	$15.71/\lambda_{lim}$
32	8368	4184	837	$41.84/\lambda_{lim}$
64	15540	7770	1554	$77.70/\lambda_{lim}$
128	29432	14716	2943	$147.16/\lambda_{lim}$
256	56575	28287	5657	$282.87/\lambda_{lim}$

2

3

1

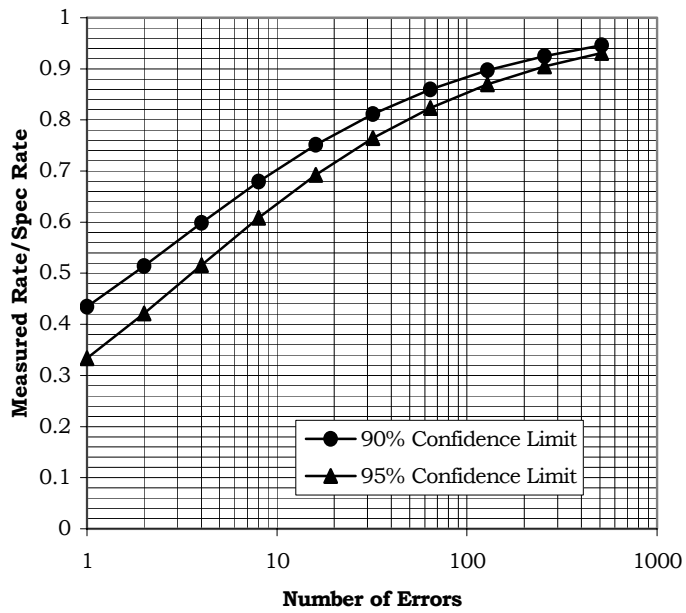
**Table 6.8-2. Trial Count (N) Thresholds for 90% Confidence**

<b>K</b>	$\lambda_{lim}$		<b>General</b>
	<b>10.0%</b>	<b>50.0%</b>	
0	24	5	N/A
1	24	5	$2.30/\lambda_{lim}$
2	39	8	$3.89/\lambda_{lim}$
3	54	11	$5.32/\lambda_{lim}$
4	67	14	$6.63/\lambda_{lim}$
5	80	16	$8.00/\lambda_{lim}$
6	93	19	$9.28/\lambda_{lim}$
7	106	22	$10.53/\lambda_{lim}$
8	118	24	$11.77/\lambda_{lim}$
9	130	26	$13.00/\lambda_{lim}$
10	143	29	$14.21/\lambda_{lim}$
32	395	79	$39.43/\lambda_{lim}$
64	745	149	$74.44/\lambda_{lim}$
128	1427	286	$142.70/\lambda_{lim}$
256	2768	554	$276.71/\lambda_{lim}$

2

3 In general, the rate ratio form of the test may be used with the curves of Figure 6.8-1 and  
 4 6.8-2. This curve is applicable to any specification error rate.

5



1  
2 **Figure 6.8-1. Rate Ratio ( $\lambda_N/\lambda_{lim}$ ) Bound as a Function of Number of Errors (K)**  
3 **for 90 and 95% Confidence**  
4  
5

1 **ANNEX A PERFORMANCE REQUIREMENTS**

2 This annex is normative.

3 **A.1 Access Channel and Enhanced Access Channel Performance**

4 These requirements are referenced by 3.2.

5

6

**Table A.1-1. Maximum Access Probe Failure Rates**

<b><math>E_b/N_0</math> per RF Input Port (dB)</b>	<b>Maximum Failure Rate</b>
(5.5 + $\Delta$ )	0.5
(6.5 + $\Delta$ )	0.1

7  $\Delta = 4.5$  for Femto Cells with 1 RF input port, and 0 for all others

8

1 **Table A.1-2. Maximum Spreading Rate 1 Enhanced Access Probe Failure Rates**

<b>R-EACH Configuration</b>	<b>Test Message</b>	<b><math>E_b/N_0</math> per RF Input Port (dB)</b>	<b>Maximum Failure Rate</b>
9.6kbps, 20ms	<i>Data Burst Message</i>	(5.7 + $\Delta$ )	0.1
		(5.1 + $\Delta$ )	0.5
	<i>Origination Message</i>	(5.3 + $\Delta$ )	0.1
		(4.5 + $\Delta$ )	0.5
19.2kbps, 10ms	<i>Data Burst Message</i>	(5.0 + $\Delta$ )	0.1
		(4.4 + $\Delta$ )	0.5
	<i>Origination Message</i>	(4.6 + $\Delta$ )	0.1
		(3.9 + $\Delta$ )	0.5
19.2kbps, 20ms	<i>Data Burst Message</i>	(5.0 + $\Delta$ )	0.1
		(4.4 + $\Delta$ )	0.5
	<i>Origination Message</i>	(4.6 + $\Delta$ )	0.1
		(3.9 + $\Delta$ )	0.5
38.4kbps, 5ms	<i>Data Burst Message</i>	(4.8 + $\Delta$ )	0.1
		(4.1 + $\Delta$ )	0.5
	<i>Origination Message</i>	(4.3 + $\Delta$ )	0.1
		(3.5 + $\Delta$ )	0.5
38.4kbps, 10ms	<i>Data Burst Message</i>	(4.6 + $\Delta$ )	0.1
		(3.9 + $\Delta$ )	0.5
	<i>Origination Message</i>	(4.2 + $\Delta$ )	0.1
		(3.4 + $\Delta$ )	0.5
38.4kbps, 20ms	<i>Data Burst Message</i>	(4.6 + $\Delta$ )	0.1
		(3.9 + $\Delta$ )	0.5
	<i>Origination Message</i>	(4.1 + $\Delta$ )	0.1
		(3.4 + $\Delta$ )	0.5

2  $\Delta = 4.5$  for Femto Cells with 1 RF input port, and 0 for all others

3

4

1 **A.2 Reverse Common Control Channel Performance**

2 A.2.1 AWGN Performance Requirements

3 These requirements are referenced by 3.3.1.

4  
5 **Table A.2.1-1. Maximum FER for Reverse Common Control Channel Demodulation**  
6 **Performance Tests in AWGN**

Data Rate (bps)	Frame Length (ms)	FER Limits (%)	
		At Lower $E_b/N_0$	At Upper $E_b/N_0$
9600	20	2.7% @ (4.0 + $\Delta$ ) dB	0.3% @ 4.6 dB
19200	20	2.6% @ (3.5 + $\Delta$ ) dB	0.4% @ 4.1 dB
19200	10	2.6% @ (3.3 + $\Delta$ ) dB	0.4% @ 3.9 dB
38400	20	2.6% @ (3.3 + $\Delta$ ) dB	0.4% @ 3.9 dB
38400	10	2.3% @ (3.2 + $\Delta$ ) dB	0.4% @ 3.8 dB
38400	5	2.3% @ (3.1 + $\Delta$ ) dB	0.4% @ 3.7 dB

7  $\Delta = 4.5$  for Femto Cells with 1 RF input port, and 0 for all others

8  
9 A.2.2 Fading Channel Performance Requirements

10 These requirements are referenced by 3.3.2.

11

1 **Table A.2.2-1. Maximum FER for Spreading Rate 1 Reverse Common Control Channel**  
 2 **Demodulation Performance Tests in Multipath Fading (Part 1 of 4)**

Case	Band Group	Data Rate (bps)	Frame Length (ms)	FER Limits (%)	
				At Lower $E_b/N_0$	At Upper $E_b/N_0$
A	800	9600	20	8.0% @ 2.7 dB	2.5% @ 3.3 dB
		19200	20	10% @ 2.2 dB	3.0% @ 2.8 dB
		19200	10	9.0% @ 2.6 dB	3.0% @ 3.2 dB
		38400	20	10% @ 2.0 dB	2.5% @ 2.6 dB
		38400	10	9.0% @ 2.3 dB	3.0% @ 2.9 dB
		38400	5	8.0% @ 2.7 dB	3.0% @ 3.3 dB
	1900	9600	20	8.5% @ 2.9 dB	3.2% @ 3.5 dB
		19200	20	9.0% @ 2.4 dB	2.8% @ 3.0 dB
		19200	10	7.5% @ 2.9 dB	3.2% @ 3.5 dB
		38400	20	9.0% @ 2.2 dB	3.0% @ 2.8 dB
		38400	10	8.0% @ 2.6 dB	3.3% @ 3.2 dB
		38400	5	7.5% @ 2.9 dB	3.5% @ 3.5 dB
	450	9600	20	9.0% @ 2.6 dB	2.5% @ 3.2 dB
		19200	20	10% @ 2.2 dB	2.8% @ 2.8 dB
		19200	10	8.0% @ 2.5 dB	3.3% @ 3.1 dB
		38400	20	10% @ 2.0 dB	2.5% @ 2.6 dB
		38400	10	8.0% @ 2.3 dB	3.0% @ 2.9 dB
		38400	5	8.0% @ 2.7 dB	3.5% @ 3.3 dB

3

1 **Table A.2.2-1. Maximum FER for Spreading Rate 1 Reverse Common Control Channel**  
 2 **Demodulation Performance Tests in Multipath Fading (Part 2 of 4)**

Case	Band Group	Data Rate (bps)	Frame Length (ms)	FER Limits (%)	
				At Lower $E_b/N_0$	At Upper $E_b/N_0$
B	800	9600	20	9.0% @ 3.2 dB	3.0% @ 3.8 dB
		19200	20	9.0% @ 2.7 dB	2.5% @ 3.3 dB
		19200	10	9.0% @ 3.2 dB	3.0% @ 3.8 dB
		38400	20	11% @ 2.5 dB	2.5% @ 3.1 dB
		38400	10	8.0% @ 2.9 dB	3.0% @ 3.5 dB
		38400	5	7.0% @ 3.4 dB	4.0% @ 4.0 dB
	1900	9600	20	8.5% @ 3.6 dB	3.0% @ 4.2 dB
		19200	20	8.5% @ 3.1 dB	3.0% @ 3.7 dB
		19200	10	7.5% @ 3.8 dB	3.0% @ 4.4 dB
		38400	20	8.5% @ 2.8 dB	2.8% @ 3.4 dB
		38400	10	8.0% @ 3.4 dB	3.5% @ 4.0 dB
		38400	5	7.0% @ 3.9 dB	3.5% @ 4.5 dB
	450	9600	20	9.0% @ 3.1 dB	3.0% @ 3.7 dB
		19200	20	9.0% @ 2.7 dB	2.5% @ 3.3 dB
		19200	10	9.0% @ 3.1 dB	3.5% @ 3.7 dB
		38400	20	9.0% @ 2.4 dB	2.5% @ 3.0 dB
		38400	10	9.0% @ 2.8 dB	3.0% @ 3.4 dB
		38400	5	8.0% @ 3.3 dB	3.0% @ 3.9 dB

3

4

1 **Table A.2.2-1. Maximum FER for Spreading Rate 1 Reverse Common Control Channel**  
 2 **Demodulation Performance Tests in Multipath Fading (Part 3 of 4)**

Case	Band Group	Data Rate (bps)	Frame Length (ms)	FER Limits (%)	
				At Lower $E_b/N_0$	At Upper $E_b/N_0$
C	800	9600	20	7.0% @ 4.0 dB	3.5% @ 4.6 dB
		19200	20	7.0% @ 3.6 dB	3.3% @ 4.2 dB
		19200	10	6.5% @ 5.2 dB	4.0% @ 5.8 dB
		38400	20	7.0% @ 3.6 dB	3.3% @ 4.2 dB
		38400	10	6.5% @ 5.1 dB	4.2% @ 5.7 dB
		38400	5	6.5% @ 5.9 dB	4.0% @ 6.5 dB
	1900	9600	20	8.0% @ 3.9 dB	3.5% @ 4.5 dB
		19200	20	7.5% @ 3.6 dB	3.5% @ 4.2 dB
		19200	10	6.5% @ 4.9 dB	4.0% @ 5.5 dB
		38400	20	7.5% @ 3.6 dB	3.5% @ 4.2 dB
		38400	10	6.5% @ 4.9 dB	4.5% @ 5.5 dB
		38400	5	6.0% @ 6.9 dB	4.0% @ 7.5 dB
	450	9600	20	7.0% @ 3.6 dB	3.5% @ 4.2 dB
		19200	20	7.5% @ 3.2 dB	3.5% @ 3.8 dB
		19200	10	6.5% @ 3.8 dB	4.0% @ 4.4 dB
		38400	20	8.0% @ 3.0 dB	3.5% @ 3.6 dB
		38400	10	7.5% @ 3.6 dB	3.8% @ 4.2 dB
		38400	5	7.0% @ 4.2 dB	3.5% @ 4.8 dB

3

4

**Table A.2.2-1. Maximum FER for Spreading Rate 1 Reverse Common Control Channel Demodulation Performance Tests in Multipath Fading (Part 4 of 4)**

Case	Band Group	Data Rate (bps)	Frame Length (ms)	FER Limits (%)	
				At Lower $E_b/N_0$	At Upper $E_b/N_0$
D	800	9600	20	9.0% @ 3.9 dB	3.0% @ 4.5 dB
		19200	20	10% @ 3.4 dB	3.0% @ 4.0 dB
		19200	10	8.0% @ 4.4 dB	3.5% @ 5.0 dB
		38400	20	10% @ 3.3 dB	2.7% @ 3.9 dB
		38400	10	8.0% @ 4.1 dB	3.5% @ 4.7 dB
		38400	5	7.0% @ 5.1 dB	4.0% @ 5.7 dB
	1900	9600	20	8.0% @ 4.2 dB	2.5% @ 4.8 dB
		19200	20	9.0% @ 3.7 dB	2.5% @ 4.3 dB
		19200	10	8.0% @ 4.5 dB	3.5% @ 5.1 dB
		38400	20	10% @ 3.5 dB	2.5% @ 4.1 dB
		38400	10	8.0% @ 4.2 dB	3.5% @ 4.8 dB
		38400	5	7.0% @ 5.2 dB	3.5% @ 5.8 dB
	450	9600	20	8.0% @ 4.0 dB	2.5% @ 4.6 dB
		19200	20	8.0% @ 3.5 dB	2.5% @ 4.1 dB
		19200	10	7.0% @ 4.6 dB	3.5% @ 5.2 dB
		38400	20	9.0% @ 3.3 dB	2.8% @ 3.9 dB
		38400	10	7.0% @ 4.4 dB	3.5% @ 5.0 dB
		38400	5	6.5% @ 5.5 dB	4.0% @ 6.1 dB

### A.3 Reverse Channel Quality Indicator Channel Performance

#### A.3.1 AWGN Performance Requirements

These requirements are referenced by 3.4.1.

1 **Table A.3.1-1. Maximum FER for Reverse Channel Quality Indicator Channel**  
 2 **Performance Tests in AWGN**

<b>Data Rate (bps)</b>	<b>FER Limits (%)</b>	
	<b>At Lower <math>E_b/N_0</math></b>	<b>At Upper <math>E_b/N_0</math></b>
3200	1.8 @ 5.8 dB	0.5 @ 6.8 dB
800	6.7 @ 2.8 dB	4.3 @ 3.8 dB

3  $\Delta = 4.5$  for Femto Cells with 1 RF input port, and 0 for all others  
 4

5 A.3.2 Fading Channel Performance Requirements with Closed Loop Power Control

6 These requirements are referenced by 3.4.2.  
 7

**Table A.3.2-1. Maximum FER for Reverse Channel Quality Indicator Channel Performance Tests in Multipath Fading**

Case	Band Group	Data Rate (bps)	FER Limits (%)	
			At Lower $E_b/N_0$	At Upper $E_b/N_0$
A	800	3200	1.6 @ 7.1 dB	0.6 @ 8.1 dB
		800	5.0 @ 4.1 dB	3.3 @ 5.1 dB
		3200	1.7 @ 7.2 dB	0.6 @ 8.2 dB
		800	4.8 @ 4.2 dB	3.0 @ 5.2 dB
		3200	1.6 @ 7.1 dB	0.6 @ 8.1 dB
		800	5.3 @ 4.1 dB	3.4 @ 5.1 dB
B		3200	3.1 @ 7.1 dB	1.2 @ 8.1 dB
		800	6.7 @ 4.1 dB	4.1 @ 5.1 dB
	1900	3200	3.1 @ 7.7 dB	1.2 @ 8.7 dB
		800	6.0 @ 4.7 dB	3.6 @ 5.7 dB
	450	3200	3.2 @ 7.0 dB	1.2 @ 8.0 dB
		800	6.3 @ 4.0 dB	4.1 @ 5.0 dB
C	800	3200	6.3 @ 7.7 dB	3.9 @ 8.7 dB
		800	6.5 @ 4.7 dB	4.6 @ 5.7 dB
	1900	3200	11.7 @ 8.1 dB	8.6 @ 9.1 dB
		800	9.5 @ 5.1 dB	7.4 @ 6.1 dB
	450	3200	4.4 @ 6.7 dB	2.0 @ 7.7 dB
		800	6.9 @ 3.7 dB	4.9 @ 4.7 dB
D	800	3200	18.0 @ 7.6 dB	12.3 @ 8.6 dB
		800	13.3 @ 4.6 dB	10.2 @ 5.6 dB
	1900	3200	24.1 @ 8.4 dB	16.4 @ 9.4 dB
		800	15.9 @ 5.4 dB	11.8 @ 6.4 dB
	450	3200	12.6 @ 7.6 dB	7.8 @ 8.6 dB
		800	11.1 @ 4.6 dB	8.2 @ 5.6 dB

#### A.4 Reverse Acknowledgment Channel Performance

##### A.4.1 AWGN Performance Requirements

These requirements are referenced by 3.5.1.

**Table A.4.1-1. Limits on False Alarm Rate (FAR) and Missed Detection Rate (MDR) for Reverse Acknowledgment Channel Performance Test in AWGN**

<b>FAR Limit (%)</b>	0.1	0.3	1
<b>MDR Limit (%)</b>	3.7	0.8	0.1

A.4.2 Fading Channel Performance Requirements with Closed Loop Power Control

These requirements are referenced by 3.5.2.

**Table A.4.2-1. Limits on False Alarm Rate (FAR) and Missed Detection Rate (MDR) for Reverse Acknowledgment Channel Performance Test 1 in Multipath Fading**

<b>Case</b>	<b>Band Group</b>	<b>FAR Limits (%)</b>				
		0.1	0.3	1	3	10
		<b>Corresponding MDR Limits (%)</b>				
A	800	4.4	1.3	0.2	0.1	NS
	1900	4.6	1.4	0.2	0.1	NS
	450	4.3	1.2	0.1	0.1	NS
B	800	5.5	1.9	0.3	0.1	NS
	1900	4.7	1.7	0.3	0.1	NS
	450	5.1	1.6	0.2	0.1	NS
C	800	10.9	5.2	1.7	0.4	0.1
	1900	17.9	11.0	4.9	1.7	0.3
	450	4.6	1.7	0.4	0.1	NS
D	800	21.2	14.1	7.4	2.7	0.5
	1900	29.7	21.6	12.3	5.8	1.3
	450	18.6	11.2	5.0	1.7	0.3

10

11

1 **A.5 Reverse Traffic Channel Performance**

2 A.5.1 AWGN Performance Requirements

3 These requirements are referenced by 3.6.1.

4  
5 **Table A.5.1-1. Maximum FER for Radio Configuration 1 Reverse Fundamental**  
6 **Channel or Reverse Supplemental Code Channel Performance Tests in AWGN**

Data Rate (bps)	FER Limits (%)	
	At Lower $E_b/N_0$ Limit of $(4.1 + \Delta)$ dB	At Upper $E_b/N_0$ Limit of $(4.7 + \Delta)$ dB
9600	3.0	0.2
4800	8.0	1.0
2400	23.0	5.0
1200	22.0	6.0

7  $\Delta = 4.5$  for Femto Cells with 1 RF input port, and 0 for all others

8  
9 **Table A.5.1-2. Maximum FER for Radio Configuration 2 Reverse Fundamental**  
10 **Channel or Reverse Supplemental Code Channel Performance Tests in AWGN**

Data Rate (bps)	FER Limits (%)	
	At Lower $E_b/N_0$ Limit of $(3.2 + \Delta)$ dB	At Upper $E_b/N_0$ Limit of $(3.8 + \Delta)$ dB
14400	5.0	0.2
7200	6.3	0.7
3600	5.8	1.0
1800	3.5	1.0

11  $\Delta = 4.5$  for Femto Cells with 1 RF input port, and 0 for all others

**Table A.5.1-3. Maximum FER for Radio Configuration 3 Reverse Fundamental Channel or Reverse Dedicated Control Channel Performance Tests in AWGN**

Data Rate (bps)	FER Limits (%)	
	At Lower $E_b/N_0$	At Upper $E_b/N_0$
9600 (5 ms)	Not specified	Not specified
9600 (20 ms)	2.3% @ (2.4 + $\Delta$ ) dB	0.3% @ (3.0 + $\Delta$ ) dB
4800	2.3% @ (3.8 + $\Delta$ ) dB	0.4% @ (4.4 + $\Delta$ ) dB
2700	2.5% @ (5.0 + $\Delta$ ) dB	0.5% @ (5.6 + $\Delta$ ) dB
1500	1.7% @ (7.0 + $\Delta$ ) dB	0.4% @ (7.6 + $\Delta$ ) dB

$\Delta = 4.5$  for Femto Cells with 1 RF input port, and 0 for all others

**Table A.5.1-4. Maximum FER for Radio Configuration 3 Reverse Supplemental Channel Performance Tests in AWGN with Convolutional Coding**

Data Rate (bps)	FER Limits (%)	
	At Lower $E_b/N_0$	At Upper $E_b/N_0$
19200	9% @ (1.7 + $\Delta$ ) dB	1.7% @ (2.3 + $\Delta$ ) dB
38400	13% @ (1.4 + $\Delta$ ) dB	2.1% @ (2.0 + $\Delta$ ) dB
76800	14% @ (1.3 + $\Delta$ ) dB	2.4% @ (1.9 + $\Delta$ ) dB
153600	14% @ (1.3 + $\Delta$ ) dB	2.4% @ (1.9 + $\Delta$ ) dB
307200	14% @ (1.8 + $\Delta$ ) dB	2.0% @ (2.4 + $\Delta$ ) dB

$\Delta = 4.5$  for Femto Cells with 1 RF input port, and 0 for all others

**Table A.5.1-5. Maximum FER for Radio Configuration 3 Reverse Supplemental Channel Performance Tests in AWGN with Turbo Coding**

Data Rate (bps)	FER Limits (%)	
	At Lower $E_b/N_0$	At Upper $E_b/N_0$
19200	20% @ (0.6 + $\Delta$ ) dB	0.9% @ (1.2 + $\Delta$ ) dB
38400	24% @ (-0.1 + $\Delta$ ) dB	0.3% @ (0.5 + $\Delta$ ) dB
76800	30% @ (-0.5 + $\Delta$ ) dB	0.2% @ (0.1 + $\Delta$ ) dB
153600	60% @ (-0.9 + $\Delta$ ) dB	0.1% @ (-0.3 + $\Delta$ ) dB
307200	90% @ (-0.3 + $\Delta$ ) dB	0.1% @ (0.3 + $\Delta$ ) dB

$\Delta = 4.5$  for Femto Cells with 1 RF input port, and 0 for all others

**Table A.5.1-6. Maximum FER for Radio Configuration 4 Reverse Fundamental Channel or Reverse Dedicated Control Channel Performance Tests in AWGN**

Data Rate (bps)	FER Limits (%)	
	At Lower $E_b/N_0$	At Upper $E_b/N_0$
9600	Not specified	Not specified
14400	2.4% @ (2.1 + $\Delta$ ) dB	0.3% @ (2.7 + $\Delta$ ) dB
7200	2.4% @ (3.1 + $\Delta$ ) dB	0.4% @ (3.7 + $\Delta$ ) dB
3600	1.7% @ (4.6 + $\Delta$ ) dB	0.3% @ 5.2 + $\Delta$ ) dB
1800	1.6% @ (6.6 + $\Delta$ ) dB	0.5% @ (7.2 + $\Delta$ ) dB

$\Delta = 4.5$  for Femto Cells with 1 RF input port, and 0 for all others

**Table A.5.1-7. Maximum FER for Radio Configuration 4 Reverse Supplemental Channel Performance Tests in AWGN with Convolutional Coding**

Data Rate (bps)	FER Limits (%)	
	At Lower $E_b/N_0$	At Upper $E_b/N_0$
28800	10% @ (1.7 + $\Delta$ ) dB	1.9% @ (2.3 + $\Delta$ ) dB
57600	12% @ (1.6 + $\Delta$ ) dB	1.7% @ (2.2 + $\Delta$ ) dB
115200	14% @ (1.6 + $\Delta$ ) dB	2.0% @ (2.2 + $\Delta$ ) dB
230400	12% @ (1.7 + $\Delta$ ) dB	1.7% @ (2.3 + $\Delta$ ) dB

$\Delta = 4.5$  for Femto Cells with 1 RF input port, and 0 for all others

**Table A.5.1-8. Maximum FER for Radio Configuration 4 Reverse Supplemental Channel Performance Tests in AWGN with Turbo Coding**

<b>Data Rate (bps)</b>	<b>FER Limits (%)</b>	
	<b>At Lower <math>E_b/N_0</math></b>	<b>At Upper <math>E_b/N_0</math></b>
28800	27% @ (0.7 + $\Delta$ ) dB	0.5% @ (1.3 + $\Delta$ ) dB
57600	28% @ (0.2 + $\Delta$ ) dB	0.2% @ (0.8 + $\Delta$ ) dB
115200	60% @ (-0.2 + $\Delta$ ) dB	0.1% @ (0.4 + $\Delta$ ) dB
230400	33% @ (-0.5 + $\Delta$ ) dB	0.1% @ (0.1 + $\Delta$ ) dB

$\Delta = 4.5$  for Femto Cells with 1 RF input port, and 0 for all others

#### A.5.2 Fading Channel Performance Requirements without Closed Loop Power

These requirements are referenced by 3.6.2 and apply to Radio Configurations 1 and 2 only.

1

**Table A.5.2-1.  $E_b/N_0$  Limits for Reverse Traffic Channel Performance Tests  
in Multipath Fading without Closed Loop Power Control**

2

RC	Band Group	Case	$E_b/N_0$ Limits (dB)	
			Lower	Upper
1	800	B	11.1	11.7
		C	11.2	11.8
		D	8.8	9.4
		D2	9.2	9.8
	1900	B	10.4	11.0
		C	9.0	9.6
		D	8.0	8.6
		D2	8.4	9.0
	450	B	12.0	12.6
		C	13.0	13.6
		D	9.3	9.9
		D2	9.7	10.3
2	800	B	10.7	11.3
		D	8.5	9.1
		D2	8.9	9.5
	1900	B	9.9	10.5
		D	7.7	8.3
		D2	8.1	8.7
	450	B	11.2	11.8
		D	8.6	9.2
		D2	9.0	9.6

3

1  
2

**Table A.5.2-2. Maximum FER for Radio Configuration 1 Reverse Traffic Channel Performance Tests in Multipath Fading (Part 1 of 2)**

Case	Band Group	Data Rate (bps)	FER Limits (%)	
			At Lower $E_b/N_0$	At Upper $E_b/N_0$
B	800	9600	1.3	0.8
		4800	1.4	0.9
		2400	1.6	1.2
		1200	1.3	0.9
	1900	9600	1.3	0.7
		4800	1.3	0.8
		2400	2.0	1.2
		1200	1.3	0.7
	450	9600	1.7	1.0
		4800	1.6	1.0
		2400	2.1	1.3
		1200	1.3	0.9
C	800	9600	1.2	0.7
		4800	1.4	0.9
		2400	2.5	1.7
		1200	2.0	1.4
	1900	9600	1.6	0.7
		4800	3.0	2.0
		2400	6.0	3.8
		1200	6.0	4.0
	450	9600	1.6	1.1
		4800	1.5	1.0
		2400	1.6	1.1
		1200	1.2	0.8

3

1  
2**Table A.5.2-2. Maximum FER for Radio Configuration 1 Reverse Traffic Channel Performance Tests in Multipath Fading (Part 2 of 2)**

Case	Band Group	Data Rate (bps)	FER Limits (%)	
			At Lower $E_b/N_0$	At Upper $E_b/N_0$
D	800	9600	1.6	0.6
		4800	2.6	1.2
		2400	6.4	3.4
		1200	5.6	3.5
	1900	9600	2.5	0.5
		4800	4.2	1.3
		2400	12.0	6.0
		1200	9.0	5.5
	450	9600	1.9	0.7
		4800	2.0	0.8
		2400	4.0	1.7
		1200	3.4	1.6
D2	800	9600	0.9	0.3
		4800	1.6	0.7
		2400	4.2	2.3
		1200	4.1	2.6
	1900	9600	0.8	0.2
		4800	2.0	0.7
		2400	8.0	3.8
		1200	6.5	4.0
	450	9600	1.1	0.4
		4800	1.2	0.5
		2400	2.6	1.0
		1200	2.4	1.1

3

4

1  
2

**Table A.5.2-3. Maximum FER for Radio Configuration 2 Reverse Traffic Channel Performance Tests in Multipath Fading (Part 1 of 2)**

Case	Band Group	Data Rate (bps)	FER Limits (%)	
			At Lower $E_b/N_0$	At Upper $E_b/N_0$
B	800	14400	1.3	0.8
		7200	1.0	0.5
		3600	0.7	0.4
		1800	0.6	0.5
	1900	14400	1.6	1.1
		7200	1.5	1.0
		3600	1.3	0.8
		1800	0.9	0.5
	450	14400	1.4	0.8
		7200	1.0	0.7
		3600	0.9	0.5
		1800	0.6	0.4
D	800	14400	1.7	0.6
		7200	1.6	0.6
		3600	1.5	0.9
		1800	2.2	1.2
	1900	14400	2.0	0.6
		7200	2.0	0.7
		3600	2.7	1.2
		1800	3.3	1.8
	450	14400	2.2	0.8
		7200	2.0	0.7
		3600	1.6	0.6
		1800	1.7	0.8

3

1 **Table A.5.2-3. Maximum FER for Radio Configuration 2 Reverse Traffic Channel**  
 2 **Performance Tests in Multipath Fading (Part 2 of 2)**

Case	Band Group	Data Rate (bps)	FER Limits (%)	
			At Lower $E_b/N_0$	At Upper $E_b/N_0$
D2	800	14400	0.9	0.3
		7200	0.9	0.4
		3600	1.1	0.6
		1800	1.5	0.9
	1900	14400	0.9	0.3
		7200	1.0	0.4
		3600	1.6	0.7
		1800	2.2	1.1
	450	14400	1.3	0.5
		7200	1.2	0.4
		3600	1.0	0.4
		1800	1.1	0.5

3  
 4 A.5.3 Fading Channel Performance Requirements with Closed Loop Power Control

5 These requirements are referenced by 3.6.3.

1  
2

**Table A.5.3-1. Maximum FER for Radio Configuration 1 Fundamental Channel Demodulation Performance Tests in Multipath Fading**

Case	Band Group	Data Rate (bps)	FER Limits (%)	
			At Lower $E_b/N_0$	At Upper $E_b/N_0$
B	800	9600	2.8% @ 5.9 dB	0.3 @ 6.5 dB
		4800	7.6 @ 5.9 dB	2.2 @ 6.5 dB
		2400	23.0 @ 5.9 dB	12.0 @ 6.5 dB
		1200	22.0 @ 5.9 dB	14.0 @ 6.5 dB
	1900	9600	2.4 @ 6.3 dB	0.4 @ 6.9 dB
		4800	10.0 @ 6.3 dB	4.5 @ 6.9 dB
		2400	20.0 @ 6.3 dB	15.0 @ 6.9 dB
		1200	25.0 @ 6.3 dB	16.0 @ 6.9 dB
	450	9600	3.5 @ 5.5 dB	0.3 @ 6.1 dB
		4800	5.5 @ 5.5 dB	0.9 @ 6.1 dB
		2400	7.5 @ 5.5 dB	2.5 @ 6.1 dB
		1200	9.0 @ 5.5 dB	4.5 @ 6.1 dB
C	800	9600	1.5 @ 7.1 dB	0.7 @ 7.7 dB
		4800	8.0 @ 7.1 dB	4.8 @ 7.7 dB
		2400	18.0 @ 7.1 dB	13.0 @ 7.7 dB
		1200	16.0 @ 7.1 dB	12.0 @ 7.7 dB
	1900	9600	1.7 @ 7.6 dB	0.7 @ 8.2 dB
		4800	6.0 @ 7.6 dB	3.0 @ 8.2 dB
		2400	13.0 @ 7.6 dB	9.0 @ 8.2 dB
		1200	13.0 @ 7.6 dB	9.0 @ 8.2 dB
	450	9600	1.7% @ 6.0 dB	0.7 @ 6.6 dB
		4800	8.0 @ 6.0 dB	4.5 @ 6.6 dB
		2400	16.0 @ 6.0 dB	11.0 @ 6.6 dB
		1200	16.0 @ 6.0 dB	11.0 @ 6.6 dB

3

1  
2

**Table A.5.3-2. Maximum FER for Radio Configuration 2 Fundamental Channel Demodulation Performance Tests in Multipath Fading**

Case	Band Group	Data Rate (bps)	FER Limits (%)	
			At Lower $E_b/N_0$	At Upper $E_b/N_0$
B	800	14400	2.8 @ 5.2 dB	0.4 @ 5.8 dB
		7200	4.7 @ 5.2 dB	1.3 @ 5.8 dB
		3600	8.7 @ 5.2 dB	4.6 @ 5.8 dB
		1800	15.0 @ 5.2 dB	9.8 @ 5.8 dB
	1900	14400	1.8 @ 5.8 dB	0.5 @ 6.4 dB
		7200	6.0 @ 5.8 dB	3.0 @ 6.4 dB
		3600	13.0 @ 5.8 dB	8.0 @ 6.4 dB
		1800	12.0 @ 5.8 dB	7.0 @ 6.4 dB
	450	14400	2.5 @ 5.0 dB	0.4 @ 5.6 dB
		7200	2.5 @ 5.0 dB	0.4 @ 5.6 dB
		3600	4.0 @ 5.0 dB	1.0 @ 5.6 dB
		1800	7.0 @ 5.0 dB	3.0 @ 5.6 dB
C	800	14400	1.3 @ 7.7 dB	0.7 @ 8.3 dB
		7200	3.2 @ 7.7 dB	1.8 @ 8.3 dB
		3600	4.7 @ 7.7 dB	3.5 @ 8.3 dB
		1800	5.2 @ 7.7 dB	3.9 @ 8.3 dB
	1900	14400	1.3 @ 8.3 dB	0.7 @ 8.9 dB
		7200	1.6 @ 8.3 dB	1.0 @ 8.9 dB
		3600	2.3 @ 8.3 dB	1.5 @ 8.9 dB
		1800	3.6 @ 8.3 dB	2.6 @ 8.9 dB
	450	14400	1.8 @ 5.6 dB	0.6 @ 6.2 dB
		7200	7.5 @ 5.6 dB	4.5 @ 6.2 dB
		3600	18 @ 5.6 dB	12 @ 6.2 dB
		1800	20 @ 5.6 dB	15 @ 6.2 dB

3

1 **Table A.5.3-3. Maximum FER for Radio Configuration 3 Fundamental Channel**  
 2 **or Dedicated Control Channel Demodulation Performance Tests**  
 3 **in Multipath Fading (Part 1 of 4)**

Case	Band Group	Data Rate (bps)	FER Limits (%)	
			At Lower $E_b/N_0$	At Upper $E_b/N_0$
A	800	9600 (5 ms)	Not specified	Not specified
		9600 (20 ms)	2.4% @ 3.4 dB	0.5% @ 4.0 dB
		4800	2.0% @ 4.4 dB	0.5% @ 5.0 dB
		2700	1.8% @ 5.6 dB	0.5% @ 6.2 dB
		1500	1.8% @ 7.2 dB	0.6% @ 7.8 dB
	1900	9600 (5 ms)	Not specified	Not specified
		9600 (20 ms)	2.0% @ 3.8 dB	0.5% @ 4.4 dB
		4800	1.7% @ 4.7 dB	0.5% @ 5.5 dB
		2700	1.8% @ 5.9 dB	0.5% @ 6.5 dB
		1500	1.5% @ 7.7 dB	0.6% @ 8.3 dB
	450	9600 (5 ms)	Not specified	Not specified
		9600 (20 ms)	2.0% @ 3.3 dB	0.4% @ 3.9 dB
		4800	1.8% @ 4.6 dB	0.5% @ 5.2 dB
		2700	1.8% @ 5.8 dB	0.6% @ 6.4 dB
		1500	1.7% @ 7.6 dB	0.6% @ 8.2 dB

4

1 **Table A.5.3-3. Maximum FER for Radio Configuration 3 Fundamental Channel**  
 2 **or Dedicated Control Channel Demodulation Performance Tests**  
 3 **in Multipath Fading (Part 2 of 4)**

Case	Band Group	Data Rate (bps)	FER Limits (%)	
			At Lower $E_b/N_0$	At Upper $E_b/N_0$
B	800	9600 (5 ms)	Not specified	Not specified
		9600 (20 ms)	2.0% @ 3.9 dB	0.5% @ 4.5 dB
		4800	2.0% @ 4.9 dB	0.5% @ 5.5 dB
		2700	1.8% @ 6.1 dB	0.5% @ 6.7 dB
		1500	1.7% @ 7.8 dB	0.5% @ 8.4 dB
	1900	9600 (5 ms)	Not specified	Not specified
		9600 (20 ms)	2.2% @ 4.5 dB	0.6% @ 5.1 dB
		4800	2.0% @ 5.5 dB	0.5% @ 6.1 dB
		2700	1.8% @ 6.7 dB	0.4% @ 7.3 dB
		1500	1.9% @ 8.6 dB	0.6% @ 9.2 dB
	450	9600 (5 ms)	Not specified	Not specified
		9600 (20 ms)	2.4% @ 3.8 dB	0.5% @ 4.4 dB
		4800	2.2% @ 4.9 dB	0.5% @ 5.5 dB
		2700	1.8% @ 6.0 dB	0.5% @ 6.6 dB
		1500	1.7% @ 7.7 dB	0.5% @ 8.3 dB

4

1 **Table A.5.3-3. Maximum FER for Radio Configuration 3 Fundamental Channel**  
 2 **or Dedicated Control Channel Demodulation Performance Tests**  
 3 **in Multipath Fading (Part 3 of 4)**

Case	Band Group	Data Rate (bps)	FER Limits (%)	
			At Lower $E_b/N_0$	At Upper $E_b/N_0$
C	800	9600 (5 ms)	Not specified	Not specified
		9600 (20 ms)	1.5% @ 5.2 dB	0.6% @ 5.8 dB
		4800	1.5% @ 6.1 dB	0.6% @ 6.7 dB
		2700	1.4% @ 7.2 dB	0.6% @ 7.8 dB
		1500	1.4% @ 8.8 dB	0.6% @ 9.4 dB
	1900	9600 (5 ms)	Not specified	Not specified
		9600 (20 ms)	1.4% @ 5.4 dB	0.5% @ 6.0 dB
		4800	1.8% @ 6.2 dB	0.6% @ 6.8 dB
		2700	1.6% @ 7.2 dB	0.6% @ 7.8 dB
		1500	1.5% @ 8.7 dB	0.7% @ 9.3 dB
	450	9600 (5 ms)	Not specified	Not specified
		9600 (20 ms)	1.7% @ 4.7 dB	0.6% @ 5.3 dB
		4800	1.8% @ 5.6 dB	0.6% @ 6.2 dB
		2700	1.7% @ 6.7 dB	0.6% @ 7.3 dB
		1500	1.5% @ 8.7 dB	0.6% @ 9.3 dB

4

1  
2  
3

**Table A.5.3-3. Maximum FER for Radio Configuration 3 Fundamental Channel  
or Dedicated Control Channel Demodulation Performance Tests  
in Multipath Fading (Part 4 of 4)**

Case	Band Group	Data Rate (bps)	FER Limits (%)	
			At Lower $E_b/N_0$	At Upper $E_b/N_0$
D	800	9600 (5 ms)	Not specified	Not specified
		9600 (20 ms)	2.0% @ 4.7 dB	0.5% @ 5.3 dB
		4800	2.0% @ 5.7 dB	0.5% @ 6.3 dB
		2700	1.8% @ 6.9 dB	0.5% @ 7.5 dB
		1500	1.7% @ 8.5 dB	0.5% @ 9.1 dB
	1900	9600 (5 ms)	Not specified	Not specified
		9600 (20 ms)	2.0% @ 5.0 dB	0.4% @ 5.6 dB
		4800	2.0% @ 5.9 dB	0.5% @ 6.5 dB
		2700	2.0% @ 7.0 dB	0.5% @ 7.6 dB
		1500	1.8% @ 8.7 dB	0.5% @ 9.3 dB
	450	9600 (5 ms)	Not specified	Not specified
		9600 (20 ms)	1.9% @ 4.8 dB	0.5% @ 5.4 dB
		4800	1.8% @ 5.7 dB	0.5% @ 6.3 dB
		2700	2.0% @ 6.9 dB	0.6% @ 7.5 dB
		1500	1.7% @ 8.5 dB	0.5% @ 9.1 dB

4  
5

1 **Table A.5.3-4. Maximum FER for Radio Configuration 3 Dedicated Control Channel**  
 2 **Demodulation Performance Tests in Multipath Fading at 10% Frame Activity**

Case	Band Group	FER Limits (%)	
		At Lower $E_b/N_0$	At Upper $E_b/N_0$
A	800	Not specified	Not specified
	1900	Not specified	Not specified
	450	Not specified	Not specified
B	800	Not specified	Not specified
	1900	Not specified	Not specified
	450	Not specified	Not specified
C	800	Not specified	Not specified
	1900	Not specified	Not specified
	450	Not specified	Not specified
D	800	Not specified	Not specified
	1900	Not specified	Not specified
	450	Not specified	Not specified

3

1 **Table A.5.3-5. Maximum FER for Radio Configuration 3 Supplemental Channel**  
 2 **Demodulation Performance Tests in Multipath Fading with Convolutional Coding**

Case	Band Group	Data Rate (bps)	FER Limits (%)	
			At Lower $E_b/N_0$	At Upper $E_b/N_0$
B	800	307200	10% @ 2.6 dB	2.0% @ 3.2 dB
		153600	10% @ 2.6 dB	2.0% @ 3.2 dB
		76800	10% @ 2.1 dB	2.4% @ 2.7 dB
		38400	9.0% @ 2.4 dB	2.4% @ 3.0 dB
		19200	9.0% @ 2.8 dB	2.5% @ 3.4 dB
	1900	307200	8.5% @ 3.0 dB	2.5% @ 3.6 dB
		153600	9.5% @ 2.4 dB	2.5% @ 3.0 dB
		76800	8.0% @ 2.6 dB	2.5% @ 3.2 dB
		38400	8.5% @ 2.8 dB	3.0% @ 3.4 dB
		19200	8.0% @ 3.3 dB	3.0% @ 3.9 dB
	450	307200	11% @ 2.5 dB	2.0% @ 3.1 dB
		153600	10% @ 1.9 dB	2.5% @ 2.5 dB
		76800	10% @ 2.0 dB	2.5% @ 2.6 dB
		38400	9.0% @ 2.3 dB	2.5% @ 2.9 dB
		19200	10% @ 2.7 dB	2.5% @ 3.3 dB

3

**Table A.5.3-6. Maximum FER for Radio Configuration 3 Supplemental Channel Demodulation Performance Tests in Multipath Fading with Turbo Coding**

Case	Band Group	Data Rate (bps)	FER Limits (%)	
			At Lower $E_b/N_0$	At Upper $E_b/N_0$
B	800	307200	15% @ 0.8 dB	1.8% @ 1.4 dB
		153600	12% @ 0.2 dB	2.0% @ 0.8 dB
		76800	10% @ 0.7 dB	2.0% @ 1.3 dB
		38400	10% @ 1.3 dB	2.0% @ 1.9 dB
		19200	10% @ 2.1 dB	2.5% @ 2.7 dB
	1900	307200	10% @ 1.3 dB	2.5% @ 1.9 dB
		153600	10% @ 0.7 dB	2.5% @ 1.3 dB
		76800	9.0% @ 1.2 dB	2.5% @ 1.8 dB
		38400	9.0% @ 1.8 dB	2.5% @ 2.4 dB
		19200	8.5% @ 2.7 dB	2.8% @ 3.3 dB
	450	307200	8.5% @ 0.7 dB	1.5% @ 1.3 dB
		153600	12% @ 0.2 dB	1.2% @ 0.8 dB
		76800	12% @ 0.6 dB	1.8% @ 1.2 dB
		38400	11% @ 1.2 dB	2.5% @ 1.8 dB
		19200	10% @ 1.9 dB	2.5% @ 2.5 dB

3

4

1  
2  
3

**Table A.5.3-7. Maximum FER for Radio Configuration 4 Fundamental Channel  
or Dedicated Control Channel Demodulation Performance Tests  
in Multipath Fading (Part 1 of 4)**

Case	Band Group	Data Rate (bps)	FER Limits (%)	
			At Lower $E_b/N_0$	At Upper $E_b/N_0$
A	800	9600	Not specified	Not specified
		14400	2.2% @ 3.2 dB	0.4% @ 3.8 dB
		7200	1.9% @ 3.9 dB	0.4% @ 4.5 dB
		3600	1.9% @ 5.1 dB	0.5% @ 5.7 dB
		1800	1.8% @ 7.0 dB	0.5% @ 7.6 dB
	1900	9600	Not specified	Not specified
		14400	1.8% @ 3.6 dB	0.5% @ 4.2 dB
		7200	1.8% @ 4.3 dB	0.4% @ 4.9 dB
		3600	1.8% @ 5.5 dB	0.5% @ 6.1 dB
		1800	1.7% @ 7.3 dB	0.6% @ 7.9 dB
	450	9600	Not specified	Not specified
		14400	2.2% @ 3.1 dB	0.5% @ 3.7 dB
		7200	2.3% @ 3.7 dB	0.5% @ 4.5 dB
		3600	1.9% @ 5.1 dB	0.5% @ 5.7 dB
		1800	1.8% @ 8.6 dB	0.5% @ 9.2 dB

4

1 **Table A.5.3-7. Maximum FER for Radio Configuration 4 Fundamental Channel**  
 2 **or Dedicated Control Channel Demodulation Performance Tests**  
 3 **in Multipath Fading (Part 2 of 4)**

Case	Band Group	Data Rate (bps)	FER Limits (%)	
			At Lower $E_b/N_0$	At Upper $E_b/N_0$
B	800	9600	Not specified	Not specified
		14400	2.0% @ 3.8 dB	0.4% @ 4.4 dB
		7200	2.0% @ 4.3 dB	0.5% @ 4.9 dB
		3600	1.8% @ 5.6 dB	0.5% @ 6.2 dB
		1800	1.8% @ 7.5 dB	0.5% @ 8.1 dB
	1900	9600	Not specified	Not specified
		14400	1.9% @ 4.3 dB	0.5% @ 4.9 dB
		7200	2.0% @ 4.9 dB	0.5% @ 5.5 dB
		3600	1.7% @ 6.1 dB	0.4% @ 6.7 dB
		1800	1.6% @ 8 dB	0.4% @ 8.6 dB
	450	9600	Not specified	Not specified
		14400	2.4% @ 3.6 dB	0.4% @ 4.2 dB
		7200	2.2% @ 4.2 dB	0.5% @ 4.8 dB
		3600	2.0% @ 5.5 dB	0.4% @ 6.1 dB
		1800	2.0% @ 7.3 dB	0.5% @ 7.9 dB

4

1 **Table A.5.3-7. Maximum FER for Radio Configuration 4 Fundamental Channel**  
 2 **or Dedicated Control Channel Demodulation Performance Tests**  
 3 **in Multipath Fading (Part 3 of 4)**

Case	Band Group	Data Rate (bps)	FER Limits (%)	
			At Lower $E_b/N_0$	At Upper $E_b/N_0$
C	800	9600	Not specified	Not specified
		14400	1.6% @ 5.1 dB	0.6% @ 5.7 dB
		7200	1.7% @ 5.6 dB	0.7% @ 6.2 dB
		3600	1.5% @ 6.7 dB	0.6% @ 7.3 dB
		1800	1.6% @ 8.4 dB	0.7% @ 9 dB
	1900	9600	Not specified	Not specified
		14400	1.8% @ 5.2 dB	0.5% @ 5.8 dB
		7200	1.8% @ 5.7 dB	0.4% @ 6.3 dB
		3600	1.7% @ 6.7 dB	0.6% @ 7.3 dB
		1800	1.6% @ 8.5 dB	0.6% @ 9.1 dB
	450	9600	Not specified	Not specified
		14400	1.6% @ 4.5 dB	0.6% @ 5.1 dB
		7200	1.6% @ 5.1 dB	0.6% @ 5.7 dB
		3600	1.7% @ 6.3 dB	0.6% @ 6.9 dB
		1800	1.8% @ 8.0 dB	0.7% @ 8.6 dB

4

1 **Table A.5.3-7. Maximum FER for Radio Configuration 4 Fundamental Channel**  
 2 **or Dedicated Control Channel Demodulation Performance Tests**  
 3 **in Multipath Fading (Part 4 of 4)**

Case	Band Group	Data Rate (bps)	FER Limits (%)	
			At Lower $E_b/N_0$	At Upper $E_b/N_0$
D	800	9600	Not specified	Not specified
		14400	2.0% @ 4.6 dB	0.5% @ 5.2 dB
		7200	2.0% @ 5.1 dB	0.5% @ 5.7 dB
		3600	1.9% @ 6.3 dB	0.5% @ 6.9 dB
		1800	1.8% @ 8.1 dB	0.6% @ 8.7 dB
	1900	9600	Not specified	Not specified
		14400	2.0% @ 4.8 dB	0.4% @ 5.4 dB
		7200	2.5% @ 5.4 dB	0.5% @ 6.0 dB
		3600	1.8% @ 6.7 dB	0.3% @ 7.3 dB
		1800	1.8% @ 8.5 dB	0.5% @ 9.1 dB
	450	9600	Not specified	Not specified
		14400	2.0% @ 4.6 dB	0.4% @ 5.2 dB
		7200	2.0% @ 5.1 dB	0.5% @ 5.7 dB
		3600	1.9% @ 6.3 dB	0.6% @ 6.9 dB
		1800	1.8% @ 7.2 dB	0.5% @ 7.8 dB

4

1 **Table A.5.3-8. Maximum FER for Radio Configuration 4 Dedicated Control Channel**  
 2 **Demodulation Performance Tests in Multipath Fading at 10% Frame Activity**

Case	Band Group	FER Limits (%)	
		At Lower $E_b/N_0$	At Upper $E_b/N_0$
A	800	Not specified	Not specified
	1900	Not specified	Not specified
	450	Not specified	Not specified
B	800	Not specified	Not specified
	1900	Not specified	Not specified
	450	Not specified	Not specified
C	800	Not specified	Not specified
	1900	Not specified	Not specified
	450	Not specified	Not specified
D	800	Not specified	Not specified
	1900	Not specified	Not specified
	450	Not specified	Not specified

3

1 **Table A.5.3-9. Maximum FER for Radio Configuration 4 Supplemental Channel**  
 2 **Demodulation Performance Tests in Multipath Fading with Convolutional Coding**

Case	Band Group	Data Rate (bps)	FER Limits (%)	
			At Lower $E_b/N_0$	At Upper $E_b/N_0$
B	800	230400	10% @ 2.4 dB	1.4% @ 3.0 dB
		115200	9.0% @ 2.5 dB	2.3% @ 3.1 dB
		57600	9.0% @ 2.6 dB	2.2% @ 3.2 dB
		28800	7.5% @ 2.8 dB	2.5% @ 3.4 dB
	1900	230400	9.0% @ 2.7 dB	2.5% @ 3.3 dB
		115200	9.0% @ 2.8 dB	2.5% @ 3.4 dB
		57600	8.5% @ 3.0 dB	2.5% @ 3.6 dB
		28800	8.5% @ 3.2 dB	2.8% @ 3.8 dB
	450	230400	10% @ 2.4 dB	2.0% @ 3.0 dB
		115200	12% @ 2.3 dB	2.5% @ 2.9 dB
		57600	10% @ 2.5 dB	2.2% @ 3.1 dB
		28800	10% @ 2.7 dB	2.5% @ 3.3 dB

3

1 **Table A.5.3-10. Maximum FER for Radio Configuration 4 Supplemental Channel**  
 2 **Demodulation Performance Tests in Multipath Fading with Turbo Coding**

Case	Band Group	Data Rate (bps)	FER Limits (%)	
			At Lower $E_b/N_0$	At Upper $E_b/N_0$
B	800	230400	10% @ 1.1 dB	2.0% @ 1.7 dB
		115200	10% @ 1.0 dB	1.5% @ 1.7 dB
		57600	11% @ 1.5 dB	1.8% @ 2.1 dB
		28800	10% @ 2.1 dB	2.0% @ 2.7 dB
	1900	230400	10% @ 1.1 dB	2.0% @ 1.7 dB
		115200	10% @ 1.5 dB	2.2% @ 2.1 dB
		57600	9.0% @ 2.0 dB	2.5% @ 2.6 dB
		28800	9.0% @ 2.6 dB	2.8% @ 3.2 dB
	450	230400	15% @ 0.5 dB	1.5% @ 1.1 dB
		115200	10% @ 0.9 dB	1.2% @ 1.5 dB
		57600	11% @ 1.4 dB	1.7% @ 2.0 dB
		28800	10% @ 2.0 dB	2.0% @ 2.6 dB

3

4

- 1 This page intentionally left blank.