

3GPP2 C.S0003-0-2

Version 1.0

Date: April 24, 2001



3RD GENERATION
PARTNERSHIP
PROJECT 2
"3GPP2"

Medium Access Control (MAC) Standard for cdma2000 Spread Spectrum Systems

Release 0 — Addendum 2

© 3GPP2 2001

3GPP2 and its Organizational Partners claim copyright in this document and individual Organizational Partners may copyright and issue documents or standards publications in individual Organizational Partner's name based on this document. Requests for reproduction of this document should be directed to the 3GPP2 Secretariat at secretariat@3gpp2.org. Requests to reproduce individual Organizational Partner's documents should be directed to that Organizational Partner. See www.3gpp2.org for more information.

UPDATE FOREWORD

(This foreword is not part of this standard)

1
2
3
4
5
6
7
8
9
10
11
12
13
14
15

This update is provided to correct errors and omissions in a previously published version of this standard.

Revisions are indicated by change bars located in the left or right hand margins, and also by specific markings applied to the text.

New text is underlined, as shown below.

This is how new text is identified.

Deleted text is crossed out, as shown below.

~~This is how deleted text is identified.~~

A modified figure is marked similarly to modified text. A new figure is underlined; a deleted figure is crossed out through the middle of the figure.

The table of contents does not identify revisions to any section heading, table, or figure.

- 1
- 2 No text
- 3

CONTENTS

1		
2		
3	1	INTRODUCTION 1-1
4	1.1	Scope 1-1
5	1.2	Document Release History 1-1
6	1.3	Terms 1-2
7	1.4	Numeric Information 1-6
8	1.5	Normative References 1-6
9	1.6	Informative References 1-6
10	1.7	Overview 1-7
11	1.7.1	Layering Model 1-8
12	1.8	Conventions Used in this Document 1-10
13	1.8.1	Service Interfaces 1-10
14	1.8.1.1	Service Primitives 1-10
15	1.8.2	Pseudo-code Rules 1-10
16	2	DEFINITION OF MAC COMPONENTS 2-12
17	2.1	Service Interfaces (<i>Informative</i>) 2-12
18	2.1.1	Service Interface Primitives Received by the MAC Layer 2-13
19	2.1.2	Service Interface Primitives Sent from the MAC Layer 2-14
20	2.1.3	Short Data Burst TeleService Service Primitives 2-15
21	2.2	Entities of the MAC Layer 2-16
22	2.2.1	Reserved 2-18
23	2.2.2	MAC Sublayer Entities 2-18
24	2.2.2.1	Short Data Bursts 2-18
25	2.2.2.1.1	Overview (<i>Informative</i>) 2-18
26	2.2.2.1.2	SDBTS 2-19
27	2.2.2.2	Mux and QoS Sublayer 2-23
28	2.2.2.2.1	The Multiplex Sublayer 2-23
29	2.2.2.2.2	SRBP and Common Channel Multiplex Sublayer 2-53
30	2.2.3	Supervisory Procedures 2-71
31	2.2.3.1	Mobile Station Transmission Statistics 2-71
32	2.2.3.1.1	Mobile Station Transmission Statistics for the FCH 2-71
33	2.2.3.1.2	Mobile Station Transmission Statistics for the DCCH 2-73
34	2.2.3.1.3	Mobile Station Transmission Statistics for the SCCH 2-75
35	2.2.3.1.4	Mobile Station Transmission Statistics for the SCH 2-76
36	2.2.3.2	Mobile Station Reception Statistics 2-77
37	2.2.3.2.1	Mobile Station Reception Statistics for the FCH 2-77
38	2.2.3.2.2	Mobile Station Reception Statistics for the DCCH 2-79
39	2.2.3.2.3	Mobile Station Reception Statistics for the SCCH 2-81
40	2.2.3.2.4	Mobile Station Reception Statistics for the SCH 2-82
41		

1	FIGURES	
2	Figure 1. cdma2000 Layer Structure	1-8
3	Figure 2. cdma2000 Entities and Service Interfaces.....	1-9
4	Figure 3. Architecture of SDBs Transported via Data Burst Messages	2-18
5	Figure 4. Format of the SDBTS-SDU	2-19
6	Figure 5. Overview of the Multiplex Sublayer Transmitting Function.	2-23
7	Figure 6. MuxPDU Types Processed by the Multiplex Sublayer.....	2-44
8	Figure 7. Sync Channel Structure (1200bps) Example	2-54
9	Figure 8. Paging Channel Structure Example	2-55
10	Figure 9. Access Attempt (Part 1)	2-57
11	Figure 10. Access Attempt (Part 2)	2-58
12	Figure 11. Example of R-ACH Slot Structure	2-60
13	Figure 12. R-ACH Structure	2-63
14	Figure 13. R-ACH Message Capsule Structure	2-64
15	Figure 14. Example of Random Access Procedures at the Mobile Station.....	2-69
16		

1
2
3
4
5
6
7
8
9
10
11
12
13
14
15
16
17
18
19
20
21
22
23
24
25
26
27
28
29
30
31
32
33
34
35
36
37
38
39
40
41
42

TABLES

Table 1. Service Interface Primitive Types	2-12
Table 2. Abbreviations for Entity Names in Service Primitives	2-13
Table 3. Service Interface Primitives Received by the MAC Layer	2-13
Table 4. Service interface Primitives Sent from the MAC Layer	2-14
Table 5. Short Data Burst TeleService Service Interface Primitives	2-15
Table 6. Multiplex Options Applicable to a FCH or DCCH.....	2-24
Table 7. Multiplex Options Applicable to SCCHs.....	2-24
Table 8. Multiplex Options Applicable to an SCH.....	2-24
Table 9. Fields Used to Compute Multiplex Option Numbers Greater than 0x10.....	2-25
Table 10. Number of LTUs in an SCH Physical Layer SDU	2-32
Table 11. Received MuxPDU Type 1 Categories and Formats for the FCH and DCCH..	2-35
Table 12. Received MuxPDU Type 2 Categories and Formats for the FCH and DCCH..	2-36
Table 13. Received MuxPDU Type 4 Categories and Formats for the FCH and DCCH..	2-37
Table 14. Received MuxPDU Type 1 Categories and Formats for the SCCH and SCH ..	2-37
Table 15. Received MuxPDU Type 2 Categories and Formats for the SCCH and SCH ..	2-38
Table 16. Received MuxPDU Type 3 Categories and Formats for the SCH.....	2-38
Table 17. MuxPDU Type 1 Formats	2-45
Table 18. MuxPDU Type 2 Formats	2-46
Table 19. MuxPDU Type 3 Formats	2-47
Table 20. MuxPDU Type 4 Formats	2-47
Table 21. Calculated, Random, and Hashed Variables	2-61
Table 22. FCH Transmission Counters for Multiplex Option 0x1	2-72
Table 23. FCH Transmission Counters for Multiplex Option 0x2	2-73
Table 24. DCCH Transmission Counters for Multiplex Option 0x1	2-74
Table 25. DCCH Transmission Counters for Multiplex Option 0x2	2-75
Table 26. SCCH Transmission Counters.....	2-76
Table 27. SCH Transmission Counters	2-77
Table 28. FCH Reception Counters for Multiplex Option 0x1	2-78
Table 29. FCH Reception Counters for Multiplex Option 0x2.....	2-79
Table 30. DCCH Reception Counters for Multiplex Option 0x1	2-80
Table 31. DCCH Reception Counters for Multiplex Option 0x2.....	2-81
Table 32. SCCH Reception Counters	2-82
Table 33. SCH Reception Counters.....	2-83

- 1
- 2 No text
- 3

1 **1 INTRODUCTION**

2 This standards specification document defines the cdma2000 Medium Access Control
3 (MAC) sublayer.

4 **1.1 Scope**

5 This standard provides the detailed definitions of all component entities within the
6 ~~cdma2000~~3GPP2-C.S0003 MAC layer, the service interfaces and primitives exchanged |
7 between entities within the MAC layer, and the service interfaces and primitives |
8 exchanged between the MAC layer and other ~~IS-2000~~cdma2000 layers.

9 **1.2 Document Release History**

10 This is the initial release of this document.

1 **1.3 Terms**

ACH	Access Channel.
Blank data block	A data block that contains no service information bits.
BS	Base station.
Configured Multiplex Option	The multiplex option number stored in the Service Configuration Record for a physical channel (see IS-2000-5 [5]).
csch	Common Signaling Channel. A point to multipoint logical channel that carries Upper Layer Signaling traffic over a common physical channel.
Data Block	The unit of information exchanged between the multiplex sublayer and a service or Upper Layer Signaling.
DCCH	Dedicated Control Channel.
Dedicated	An attribute of the forward or reverse logical channel, implying that the channel can only be used by a single user.
dsch	Dedicated Signaling Channel. A point-to-point logical channel that carries Upper Layer Signaling traffic over a dedicated physical channel.
dtch	Dedicated Traffic Channel. A point-to-point logical channel that carries data or voice traffic over a dedicated physical channel.
Event	A stimulus generated outside of an entity that triggers some procedure within the entity.
FCH	The Physical Layer Fundamental Channel.
f-csch	Forward Common Signaling Channel. A csch that carries information from the base station to the mobile station.
f-dsch	Forward Dedicated Signaling Channel. A dsch that carries information from the base station to the mobile station.
f-dtch	Forward Dedicated Traffic Channel. A dtch that carries information from the base station to the mobile station.
Fill MuxPDU	A MuxPDU Type 3 that is not associated with any service, used as filler when assembling a Physical Layer SCH SDU.
F-PCH	Forward Paging Channel. The physical channel that carries Common Channel information on the forward link and that is backward compatible with the TIA/EIA-95-B Paging Channel.
Frame duration	The duration of a physical channel transmission interval; may be 5, 10, or 20 ms.

IMSI	International Mobile Station Identifier. A universal address that uniquely identifies any mobile station.
LAC	Link Access Control. Entity that provides reliable or unreliable delivery of information across the air interface between the mobile station and the base station.
Logical Channel	Logical connection between peer entities.
LPM	Logical-to-Physical Mapping. Information that is used by the Multiplex Sublayer <u>multiplex sublayer</u> for performing the logical-to-physical channel mapping. See TIA/EIA/IS-2000-5 <u>[5]</u> .
LTU	Logical Transmission Unit. One or more Type 3 MuxPDUs with a 16 bit CRC.
MAC	Medium Access Control. Entity that controls the access to and from Upper Layer Signaling, Data Services, and Voice Services to Physical Layer resources.
Mode A	Multiplex S <u>s</u> ublayer operational mode <u>in which the Radio Configuration is less than or equal to 2, that supports compatibility with the TIA/EIA-95-B Physical Layer.</u>
Mode B	Multiplex S <u>s</u> ublayer operational mode <u>in which the Radio Configuration is greater than 2, that supports compatibility with the edma2000 Physical Layer.</u>
MS	Mobile station.
Multiplex Option	Used to specify the multiplex sublayer operation for a physical channel. Each Multiplex Option specifies the available data rates for the physical channel (FCH, DCCH or max SCH rate).
MuxPDU	Multiplex s <u>s</u> ublayer Protocol Data Unit. One or more data blocks combined according to multiplex option rules.
Null MuxPDU	A MuxPDU that contains no bits.
Null State	A state of the Data PLICF in which no data service has been activated, no service option has been connected, and no forward or reverse dedicated channels are allocated.
Null Traffic MuxPDU	A MuxPDU containing only the lowest negotiated transmit rate primary traffic data block with all bits set to '1'.
PDU	Protocol Data Unit. An atomic set of data, header information, and control information that is provided by a service user to a service provider.
Physical Channel	Point-to-point radio transmission link.

Physical Layer SDU	An SDU that is generated by the Mux and QoS Entity that is provided to the Physical Layer for transmission.
Primitive	An abstract, atomic, implementation-independent representation of an interaction between a service user and its service provider. See [7]ITU-T Recommendation X.210 .
QOF	Quasi-Orthogonal Function. Sets of numerical sequences that are used in place of Walsh codes, and which have pair-wise low cross correlations, but which are less than perfectly orthogonal.
QoS	Quality of Service. Metrics that affect the quality of a data service that is delivered to an end user (e.g., throughput, guaranteed bit rate, delay, etc.).
Rate Set 1	The set of data rates 9.6, 4.8, 2.7/2.4, 1.5/1.2, and all integral multiples of 9.6 Kbps.
Rate Set 2	The set of data rates 14.4, 7.2, 3.6, 1.8, and all integral multiples of 14.4 Kbps.
r-csch	Reverse Common Signaling Channel. A csch that carries information from the mobile station to the base station.
r-dsch	Reverse Dedicated Signaling Channel. A dsch that carries information from the mobile station to the base station.
r-dtch	Reverse Dedicated Traffic Channel. A dtch that carries information from the mobile station to the base station.
RLP	Radio Link Protocol. Connection-oriented, negative acknowledgment-based data delivery protocol.
SCCH	Supplemental Code Channel. The Physical Layer Supplemental Code Channel.
SCH	Supplemental Channel. The Physical Layer Supplemental Channel.
SDB	Short Data Burst. Bearer data from a data service transmitted by the SDBTS teleservice.
SDBTS	Short Data Burst Tele-Service. Entity that provides a mapping of the generic Signaling teleservices capabilities (transported by Common Channel <i>Data Burst Messages</i>) to the service interface expected by the data services.

SDU	Service Data Unit. A set of data, header information, and control information that is accepted by a service provider from a service user.
Signaling data block	The unit of data exchanged between the multiplex sublayer and signaling.
Signaling Traffic	Another name for the signaling information bits.
sr_id	Service Reference identifier. A unique number assigned to each connected service option instance.
SRBP	Signaling Radio Burst Protocol. An entity that provides connectionless protocol for Signaling messages.

1.4 Numeric Information

Numeric information is defined in ~~IS-2000-5~~[5]. The following are additional internal values that are defined in this standard. The values are stored by the mobile station in temporary memory and are not sent over the air. The scope of these internal values is limited to this standard.

ACH_FRAME_SIZE – Size, in bits, of the R-ACH physical layer frame. The value of ACH_FRAME_SIZE is 88.

PCH_FRAME_SIZE – Size, in bits, of the F-PCH physical layer frame.

SYNC_FRAME_SIZE – Size, in bits, of the F-SYNC physical layer frame. The value of SYNC_FRAME_SIZE is 32.

1.5 Normative References

The following standards contain provisions that, through reference in this text, constitute provisions of this Standard. At the time of publication, the editions indicated were valid. All standards are subject to revision, and parties to agreements based on this Standard are encouraged to investigate the possibility of applying the most recent editions of the standards indicated below. ANSI and TIA maintain registers of currently valid national standards published by them.

[1] Reserved.

[2] [C.S0002-0-2](#), Physical Layer Standard for cdma2000 Spread Spectrum Systems.

[3] [C.S0003-0-2, Medium Access Control \(MAC\) Standard for cdma2000 Spread Spectrum Systems.](#)

[4] [C.S0004-0-2](#), Link Access Control (LAC) Standard for cdma2000 Spread Spectrum Systems.

[5] [C.S0005-0-2](#), Upper Layer (Layer 3) Signaling Standard for cdma2000 Spread Spectrum Systems.

[6] Reserved.

[7] Recommendation X.210 (11/93) – Information technology – Open Systems Interconnection – Basic reference model: Conventions for the definition of OSI services, International Telecommunication Union.

[8] TSB58, Administration of Parameter Value Assignments for TIA/EIA Wideband Spread Spectrum Standards.

1.6 Informative References

This section is intentionally left blank.

1.7 Overview

Section 1 contains an overview of this standard. Section 2 defines the normative behavior of the IS-2000 MAC sublayer by describing the precise processing rules for each of the MAC sublayer entities. Section 2 also describes the overall structure of the IS-2000 MAC sublayer, defines the entity and service model that is used within this standard, and specifies the entities that comprise the MAC sublayer. As shown in Figure 1, IS-95¹ has a layered structure providing voice, packet data, simple circuit data (e.g., async Fax), and simultaneous voice and packet data services. At the most basic level, cdma2000 provides protocols and services that correspond to the bottom two layers of the ISO/OSI Reference Model (i.e., Layer 1 - the Physical Layer, and Layer 2 - the Link Layer) according to the general structure specified by the ITU for IMT-2000 systems. Layer 2 is further subdivided into the Link Access Control (LAC) sublayer and the Medium Access Control (MAC) sublayer. Applications and upper layer protocols, corresponding to OSI Layers 3 through 7, utilize the services provided by the cdma2000 LAC services. Examples include Signaling Services, Voice Services, Packet Data Applications, and Circuit Data Applications.

Motivated by higher bandwidths and the need to handle a wider variety of services, several enhancements have been incorporated into cdma2000. In cdma2000, a generalized multi-media service model is supported. This allows a combination of voice, packet data, and circuit data services to be operating concurrently (within the limitations of the air interface system capacity). cdma2000 also includes a Quality of Service (QoS) control mechanism to balance the varying QoS requirements of multiple concurrent services.

¹ In this section, the term "IS-95" denotes any of the standards that are predecessors to cdma2000, i.e., IS-95, IS-95-A, and TIA/EIA-95-B.

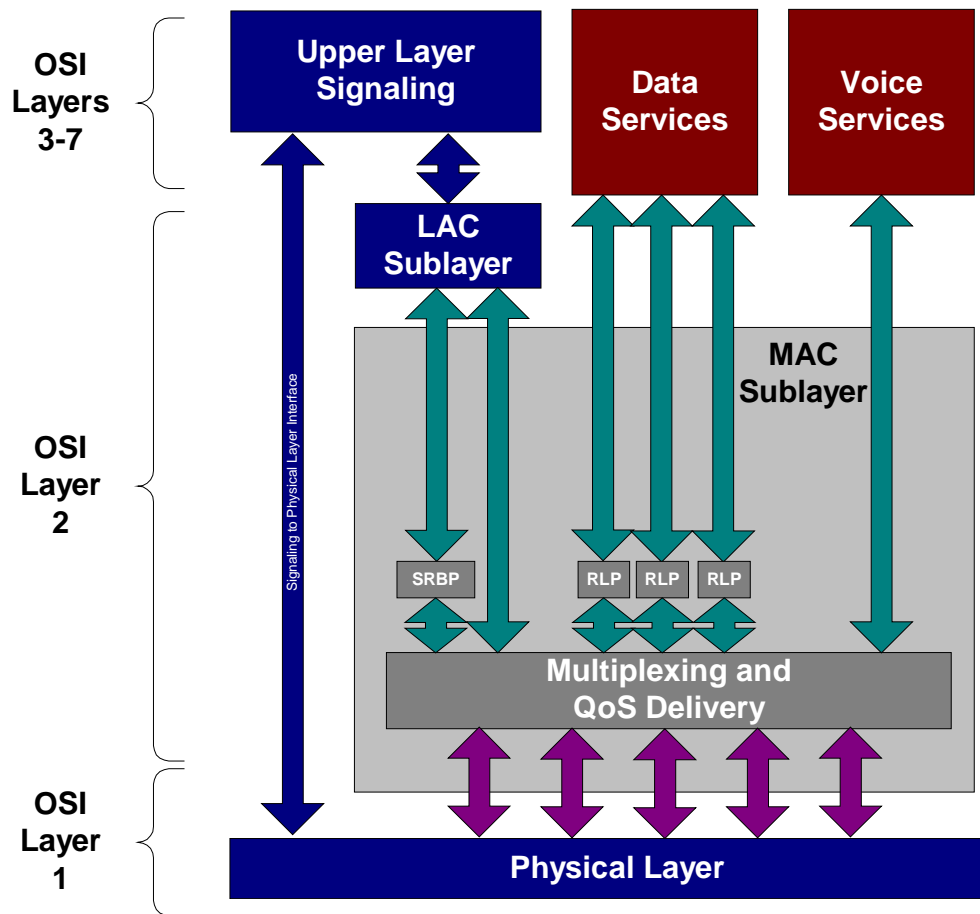

Figure 1. IS-95 and cdma2000 Layer Structure

The cdma2000 MAC sublayer provides two important functions:

-
- Best Effort Delivery - reasonably reliable transmission over the radio link with a Radio Link Protocol (RLP) that provides a “best effort” level of reliability; and
- Multiplexing and QoS Control - enforcement of negotiated QoS levels by mediating conflicting requests from competing services and the appropriate prioritization of access requests.

1.7.1 Layering Model

Figure 2 depicts the cdma2000 entities and services interfaces.

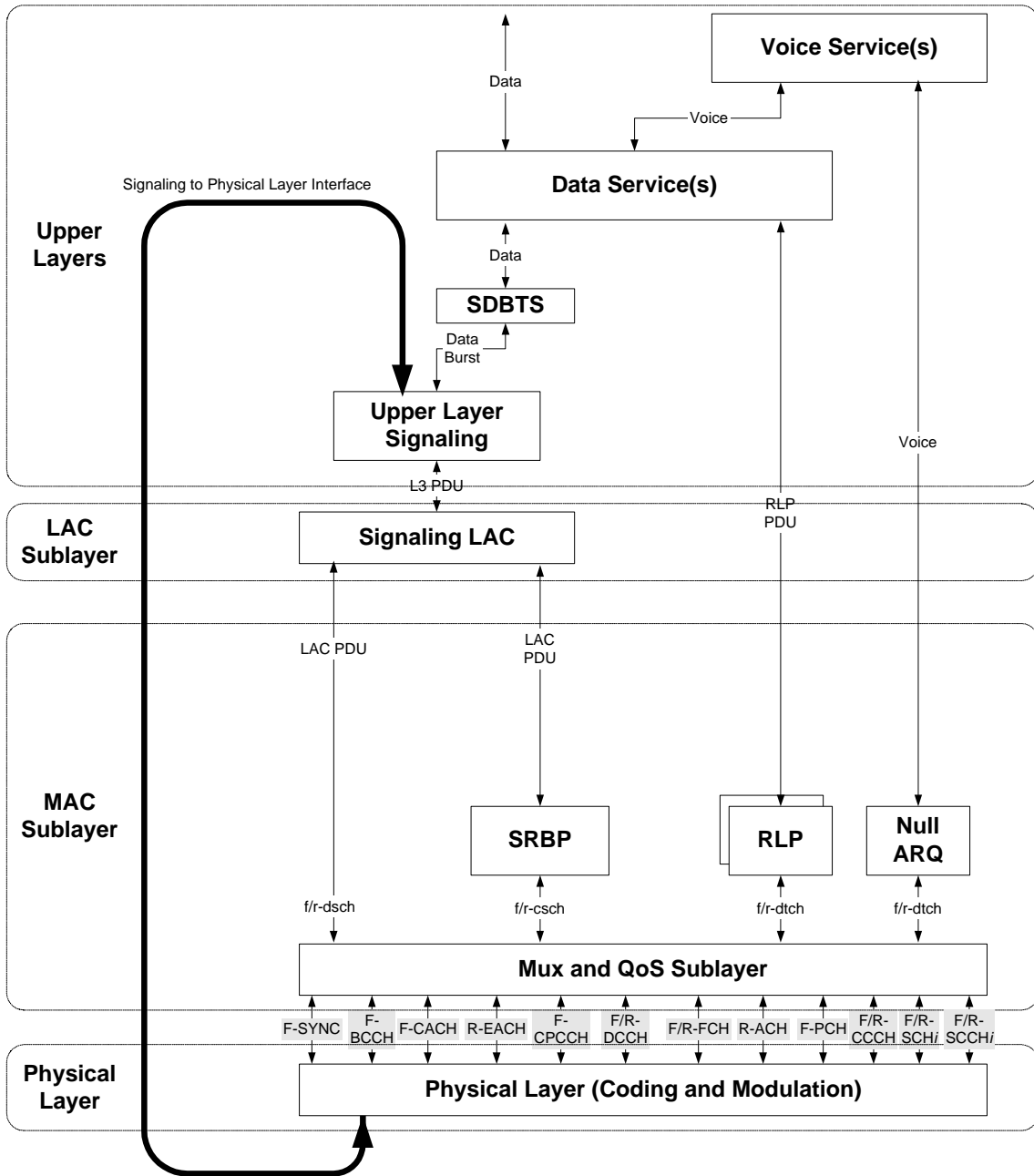

Figure 2. cdma2000 Entities and Service Interfaces

1
2
3

1 **1.8 Conventions Used in this Document**

2 **1.8.1 Service Interfaces**

3 **1.8.1.1 Service Primitives**

4 Service primitives are abstract, atomic, implementation-independent representations of
5 interactions between a service user and its service provider. No requirement is placed
6 on the mobile station or the base station to implement specific service primitives. See
7 | ~~ITU-T Recommendation X.210~~[\[7\]](#).

8 **1.8.2 Pseudo-code Rules**

9 Pseudo-code to describe procedures in this standard will follow the flow control and
10 syntax of the C++ programming language.
11

- 1
- 2 No text.
- 3

1 **2 DEFINITION OF MAC COMPONENTS**

2 **2.1 Service Interfaces (Informative)**

3 This section describes the functional service interfaces between entities of the MAC
4 sublayer and other entities outside the MAC sublayer. To support the multi-media
5 capabilities required by cdma2000, it is necessary that the abstract functional
6 description of the air interface (primarily the precise definition of the mobile station's
7 operation) be decomposed into narrowly defined *functional entities*. Furthermore, each
8 of these functional entities is described by:

- 9 • a set of *service interface primitives* for every event that acts as a stimulus for a
10 functional entity (informative);
- 11 • a set of *procedures* that the functional entity is to follow when a valid primitive is
12 encountered in each state (e.g., set a timer, modify a variable, etc.) (normative).

13 The normative portions of the entity definitions are found in Section2.

14 The following subsections contain a summary of the service interface definitions. The
15 conventions that are used for service interface primitives are shown in Table 1, and
16 conform to ~~ITU-T Recommendation X.210~~[\[7\]](#).

17 **Table 1. Service Interface Primitive Types**

Primitive Type	Source	Destination	Purpose
<i>Request</i>	service user	service provider	Request a service, resource, etc.
<i>Confirm</i>	service provider	service user	Response (positive or negative) to a Request primitive.
<i>Indication</i>	service provider	service user	Indicates that data has arrived or an event for the service user has occurred.
<i>Response</i>	service user	service provider	Acknowledgment of an Indication.

18

1 The invocation of service primitives is notated as follows:

2 *RX-Primitive.Primitive_Type* (parameters)

3 where:

RX - An abbreviation for the service provider entity (e.g., MAC for the MAC sublayer); see Table 2

Primitive - The name of the specific primitive to or from the service provider (e.g., "Data")

Primitive_Type - The specific Primitive Type as defined in Table 1 (e.g., Request)

parameters - An (optional) list of parameters for the primitive (e.g., *channel_type*, *data*, *size*)

4

5 For example, a request to the MAC sublayer to transmit data specified by the variable
6 *data*, of *channel_type* type *channel_type*, and size *size*, is notated as follows:

7 MAC-Data.Request (*channel_type*, *data*, *size*)

8 Table 2 summarizes the abbreviations (*RX*) that are used in Service Primitive names for
9 various entities that are providers of services.

10

Table 2. Abbreviations for Entity Names in Service Primitives

Entity (Service Provider)	Abbreviation (<i>RX</i>)	Primitives Defined In
Medium Access Control Layer	MAC	[3]
Physical Layer	PHY	[2]
Short Data Burst TeleService	SDBTS	[3]

11

2.1.1 Service Interface Primitives Received by the MAC Layer

12

The primitives sent from the Signaling LAC to the MAC are summarized in Table 3.

13

Table 3. Service Interface Primitives Received by the MAC Layer

Primitive Type	Primitive	Parameters	Notes
<i>Request</i>	MAC-SDUReady	<i>channel_type</i> , <i>size</i> , <i>P</i> , <i>seqno</i> , <i>scheduling_hint</i>	Initiates sending of a MAC SDU. <i>channel_type</i> is the type of data (e.g., 5 ms or 20 ms);

			<p><i>size</i> is the size of the SDU in bits;</p> <p><i>P</i> is the value used in the persistence test;² and</p> <p><i>seqno</i> is the access probe count within the current access sub-attempt.³</p> <p><i>scheduling_hint</i> is an indicator to the multiplex sublayer on how to prioritize fragments of the Layer 2 encapsulated PDU relative to other types of multiplexed traffic (e.g., to determine whether to use blank-and-burst or dim-and-burst)⁴.</p>
<i>Request</i>	MAC-Data	<i>channel_type</i> , <i>data</i> , <i>size</i>	<p>In response to the MAC-Availability Indication primitive, this primitive carries the data to be transmitted.</p> <p><i>channel_type</i> is the type of <i>data</i> (e.g., 5 ms or 20 ms);</p> <p><i>data</i> is an SDU or a fragment of an SDU; and</p> <p><i>size</i> is the size of <i>data</i> in bits.</p>

1 **2.1.2 Service Interface Primitives Sent from the MAC Layer**

2 The primitives sent from the MAC entity to the LAC entity are shown in Table 4.

3 **Table 4. Service interface Primitives Sent from the MAC Layer**

Primitive Type	Primitive	Parameters	Notes
<i>Indication</i>	MAC-Data	<i>channel_id</i> , <i>type</i> , <i>data</i> , <i>size</i> , <i>system_time</i>	<p>The MAC Layer delivers <i>data</i>.</p> <p><i>channel_id</i> is a channel identifier for the physical channel on which the data was received (see 2.2.2.2.4);</p> <p><i>type</i> is the type of <i>data</i> (e.g., 5 ms or 20 ms);</p> <p><i>data</i> is an SDU or a fragment of an SDU;</p> <p><i>size</i> is the size of <i>data</i> in bits; and</p> <p><i>system_time</i> is the time at which the Physical Layer received the first bit of the Physical Layer frame containing <i>data</i>.</p>
<i>Indication</i>	MAC-Availability	<i>channel_type</i> , <i>max_size</i> , <i>system_time</i>	<p>Indication of the maximum number of bits that can be transmitted by the next frame.</p> <p><i>channel_type</i> is the type of data to be transmitted (e.g., 5 ms, 20 ms, or either);</p>

² Only used for the r-csch.

³ Only used for the r-csch.

⁴ Only used for the dsch.

			<p><i>max_size</i> is the maximum number of bits that can be placed in the Physical Layer SDU; and</p> <p><i>system_time</i> is the time at which the Physical Layer will transmit the first bit of the Physical Layer frame containing all the information bits supplied.</p>
<i>Indication</i>	MAC-AccessFailure	<i>reason</i>	<p><i>reason</i> is the reason for the access failure. <i>reason</i> may have one of the following values: "EACAM Not Received" or "Insufficient Transmission Rate".</p>

1 **2.1.3 Short Data Burst TeleService Service Primitives**

2 Table 5 summarizes the service primitives for the Short Data Burst TeleService entity.

3 **Table 5. Short Data Burst TeleService Service Interface Primitives**

Primitive Type	Primitive	Parameters	Notes
<i>Request</i>	<i>SDBTS-Data</i>	<i>sr_id, so, length, DataBlock, addr_type, addr_len, address</i>	The data service sends an SDB to SDBTS. SDBTS sends a <i>Data Burst Message</i> with CHARi fields containing <i>sr_id, so</i> and <i>DataBlock</i> , and NUM_FIELDS set to <i>length+3</i> . Base station SDBTS also has ADDR_TYPE field set to <i>addr_type</i> , ADDR_LEN field set to <i>addr_len</i> , and ADDRESS field set to <i>address</i> .
<i>Confirm</i>	<i>SDBTS-Data</i>		
<i>Indication</i>	<i>SDBTS-Data</i>	<i>so, length, DataBlock</i>	SDBTS delivers to the data service the received <i>Data Burst Message</i> with <i>so</i> and <i>DataBlock</i> set to the corresponding CHARi fields, and <i>length</i> set to the value in NUM_FIELDS field less 3.
<i>Response</i>	<i>SDBTS-Data</i>		

4

1 **2.2 Entities of the MAC Layer**

2 This section defines each of the entities in the MAC Layer and defines the procedures that these entities follow
3 when processing events and service primitives from other entities. The subsections in this section may contain
4 informative text that is designated *Informative* in the section heading. Otherwise, the subsections contain
5 normative text.

Objects



1 **2.2.1 Reserved**

2 **2.2.2 MAC Sublayer Entities**

3 **2.2.2.1 Short Data Bursts**

4 **2.2.2.1.1 Overview (Informative)**

5 Transmission procedures do not permit more than one Short Data Burst transmission
 6 to be outstanding for a given sr_id at the same time. Reception and transmission of a
 7 Short Data Burst may occur simultaneously.

8 Figure 3 shows an overview of the data flow when transporting SDBs via *Data Burst*
 9 *Messages*. A new entity, the *Short Data Burst TeleService* (SDBTS), provides a mapping
 10 of the Signaling teleservices capabilities to the service interface expected by the data
 11 service instance.

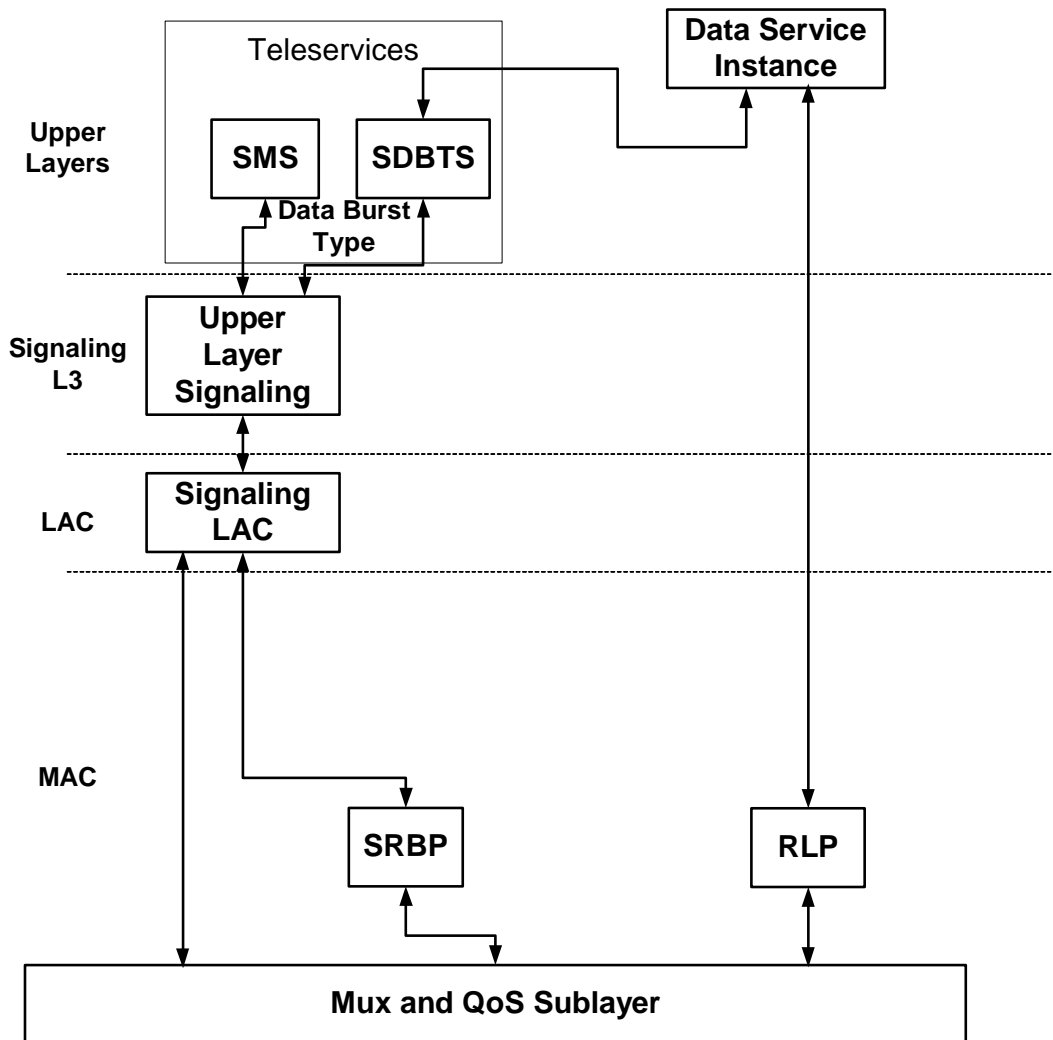

12

13 **Figure 3. Architecture of SDBs Transported via Data Burst Messages**

1 Attributes of an SDB include the data block, the data length, the service option number
 2 to which the data service was connected, the Service Reference Identifier, and, for a
 3 mobile termination SDB, address information of the mobile station. The specific Service
 4 Reference, *sr_id*, is used by the receiver SDBTS entity to direct other attributes of the
 5 SDB to the corresponding data service instance. The service option number is used by
 6 the receiver to deliver the data block and its length to the appropriate data service
 7 instance Link Layer entity.

8 Upon the reception of an SDBTS-Data.Request (*sr_id*, *so*, *length*, *DataBlock*) primitive,
 9 the SDBTS entity encapsulates the SDB by forming an SDBTS-SDU as shown in Figure
 10 4 and sends it to the expected service interface of the Upper Layer Signaling *Data Burst*
 11 service (i.e., the Teleservices service interface). The Upper Layer Signaling entity
 12 delivers the provided *Data Burst* SDU using Upper Layer Signaling procedures and *Data*
 13 *Burst Message* over the air. The BURST_TYPE field of the *Data Burst Message* is set to
 14 Short Data Burst and the CHARi fields are set to the SDU to be transmitted. When the
 15 delivery of SDB completes (either a layer 2 acknowledgment for the *Data Burst Message*
 16 is received or the acknowledgment fails), the SDBTS responds with an SDBTS-
 17 Data.Confirm (*sr_id*, *so*) primitive to indicate the end of SDB transmission.

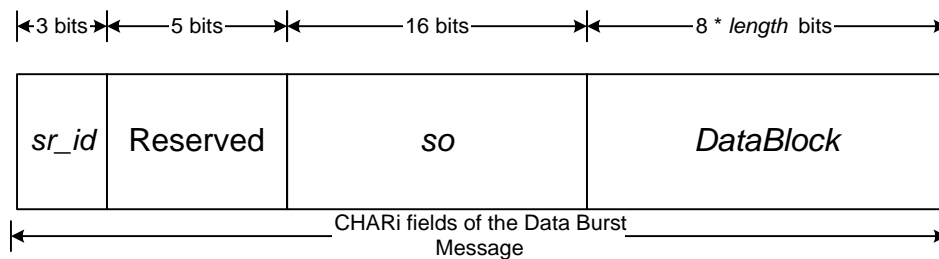

18

19

Figure 4. Format of the SDBTS-SDU

20 On the receiver, the data flow occurs along the same interfaces, but in the opposite
 21 direction. Incoming *Data Burst Messages* are delivered to the appropriate teleservice by
 22 the BURST_TYPE field. Upon receiving a *Data Burst Message* with BURST_TYPE equal
 23 to Short Data Burst, the SDBTS entity passes the received SDU to the data service
 24 instance corresponding to the received *sr_id*.

25 **2.2.2.1.2 SDBTS⁵**

26 **2.2.2.1.2.1 Mobile Station Procedures**

27 **2.2.2.1.2.1.1 Transmitting Procedures**

28 Upon receiving an SDBTS-Data.Request (*sr_id*, *so*, *length*, *DataBlock*) primitive from the
 29 data service instance associated with *sr_id*, the mobile station SDBTS entity shall
 30 perform the following procedures:

⁵ While the SDBTS is not part of MAC or L2, it is being specified here since it is closely tied to the approach used for short data bursts (SDBs) as supported in [3].

- 1 – The SDBTS shall compose an SDBTS-SDU as defined in 2.2.2.1.2.3 with the
2 sr_id field set to *sr_id*, the so field set to *so*; and the SDU_DATA field set to
3 the data in *DataBlock*.
- 4 – If AUTH_s is set to '01', the SDBTS shall generate an SDB_AUTH variable
5 consisting of up to six 4-bit digits for authentication and an SDB_AUTH_LEN
6 variable indicating the number of digits included in SDB_AUTH. The SDBTS
7 shall use the first 24 bits of SDU_DATA, or entire SDU_DATA if less than 24
8 bits, to form SDB_AUTH according to the procedures defined in ~~IS-2000-5~~[5].
- 9 – The SDBTS entity shall form a *Data Burst Message* (see ~~IS-2000-5~~[5]) with
10 BURST_TYPE set to the value corresponding to Short Data Burst (See
11 ~~TSB58~~[8]), NUM_MSGS and MSG_NUMBER set to 1, NUM_FIELDS set to
12 *length+3*, and CHAR_i fields containing the SDBTS-SDU. Variable SDB_AUTH
13 and SDB_AUTH_LEN shall be used to compute the authentication fields of
14 the *Data Burst Message* in accordance with the procedures defined in ~~IS-~~
15 ~~2000-5~~[5].

16 The mobile station shall send the *Data Burst Message* and transmit it following the
17 procedures defined in ~~IS-2000-5~~[5]. The *Data Burst Messages* always require a layer 2
18 acknowledgment. The SDBTS entity shall set the ACK_REQ layer 2 field to '1'.

19 Whether the access attempt is acknowledged or fails (see ~~IS-2000-5~~[5]), the SDBTS shall
20 respond to the data service instance with an SDBTS-Data.Confirm (*sr_id*, *so*) primitive
21 indicating the end of current SDB transmission session. The SDBTS shall ignore a new
22 SDBTS-Data.Request primitive before the current SDB transmission ends.

23 2.2.2.1.2.1.2 Receiving Procedures

24 A mobile station that supports SDB capability shall process all *Data Burst Messages*
25 received in which the BURST_TYPE field is set to the value corresponding to Short Data
26 Burst (See ~~TSB58~~[8]). Layer 2 acknowledgment shall always be returned whether or not
27 message errors are detected by the SDBTS entity. The mobile station SDBTS shall
28 discard the message without further processing if any of the following is true:

- 29 – MSG_NUMBER field is set to a value other than 1.
30 – NUM_MSGS field is set to a value other than 1.
31 – NUM_FIELDS field is set to zero.

32 Otherwise, the mobile station SDBTS shall interpret the CHAR_i fields of the received
33 *Data Burst Message* as an SDBTS-SDU as defined in 2.2.2.1.2.3 and extract the SR_ID,
34 SO, and SDU_DATA fields accordingly. The mobile station SDBTS shall send an
35 SDBTS-Data.Indication (*so*, *length*, *DataBlock*) primitive to the data service instance
36 associated with Service Reference *sr_id* and has the so field set to *so*, with *length* set to
37 the value in the NUM_FIELDS field of the received *Data Burst Message* less 3, and
38 *DataBlock* set to SDU_DATA.

39 Upon receiving an SDBTS-Data.Response (), the SDBTS entity shall take no action.

40 2.2.2.1.2.2 Base Station Procedures

41 2.2.2.1.2.2.1 Transmitting Procedures

42 Upon receiving an SDBTS-Data.Request (*sr_id*, *so*, *length*, *DataBlock*, *addr_type*,
43 *addr_len*, *address*) primitive from the data service instance associated with *sr_id*, the
44 base station SDBTS entity shall perform the following procedures:

- 1 – The SDBTS shall compose an SDBTS-SDU as defined in 2.2.2.1.2.3 with the
2 sr_id field set to *sr_id*, the so field set to *so*; and the SDU_DATA field set to
3 the data in *DataBlock*.
- 4 – The SDBTS entity shall form a *Data Burst Message* (see ~~IS-2000-5[5]~~) with
5 BURST_TYPE set to the value corresponding to Short Data Burst (See
6 ~~TSB58[8]~~), NUM_MSGS and MSG_NUMBER set to 1, NUM_FIELDS set to
7 *length+3*, CHARi fields containing the SDBTS-SDU, and ADDR_TYPE,
8 ADDR_LEN, ADDRESS field set to *addr_type*, *addr_len*, *address*,
9 respectively.

10 The base station shall send the *Data Burst Message* and transmit it, following the
11 procedures specified in ~~IS-2000-5[5]~~. The *Data Burst Messages* always require a layer 2
12 acknowledgment. The SDBTS entity shall set the ACK_REQ layer 2 field to '1'.

13 Whether or not the *Data Burst Message* is acknowledged (see ~~IS-2000-5[5]~~), the SDBTS
14 shall respond to the data service instance with an SDBTS-Data.Confirm (*sr_id*, *so*)
15 primitive indicating the end of current SDB transmission session. The SDBTS shall
16 ignore a new SDBTS-Data.Request primitive before the current SDB transmission ends.

17 **2.2.2.1.2.2.2 Receiving Procedures**

18 A base station that supports SDB capability shall process all *Data Burst Messages*
19 received on a common traffic channel in which the BURST_TYPE field is set to the value
20 corresponding to Short Data Burst (sSee ~~TSB58[8]~~). The Layer 2 acknowledgment shall
21 always be returned whether or not message errors are detected by the SDBTS entity.
22 The base station SDBTS shall discard the message without further processing if any of
23 the following is true:

- 24 – MSG_NUMBER field is set to a value other than 1.
25 – NUM_MSGS field is set to a value other than 1.
26 – NUM_FIELDS field is set to zero.

27 Otherwise, the base station SDBTS shall interpret the CHARi fields of the received *Data*
28 *Burst Message* as an SDBTS-SDU, as defined in 2.2.2.1.2.3, and extract the sr_id, so
29 and SDU_DATA field accordingly. If authentication is enabled in the serving system,
30 the SDBTS should perform the following authentication procedures in accordance with
31 ~~IS-2000-5[5]~~:

- 32 – The base station SDBTS should form the authentication digits as described
33 in 2.2.2.1.2.1.1 from SDU_DATA.
- 34 – The base station SDBTS should use the sequence of digits to compute the
35 authentication signature and should compare the computed signature with
36 the value in the AUTHR field of the received *Data Burst Message*.
- 37 – The base station SDBTS should compare the value in the RANDC field of the
38 received *Data Burst Message* with the most significant eight bits of its
39 internally stored value of RAND.
- 40 – The base station SDBTS should compare the value in the COUNT field of the
41 received *Data Burst Message* with its internally stored value associated with
42 the received IMSI/ESN.

43 If the authentication is successful, the base station SDBTS shall send an SDBTS-
44 Data.Indication (*so*, *length*, *DataBlock*) primitive to the data service instance associated
45 with Service Reference *sr_id* and with the so field set to *so*, *length* set to the value in the
46 NUM_FIELDS field of the received *Data Burst Message* minus 3, and *DataBlock* set to
47 SDU_DATA.

1 Upon receiving an SDBTS-Data.Response (), the SDBTS entity shall take no action.

2 **2.2.2.1.2.3 SDBTS-SDU Format**

3 The mobile station or base station shall use the following variable length format for the
4 SDBTS-SDU:

Field	Length (bits)
SR_ID	3
RESERVED	5
SO	16
SDU_DATA	Variable

5

6 SR_ID - Service Reference Identifier.

7 The mobile station or base station shall set this field to the
8 Service Reference of the data service.

9 RESERVED - Reserved bits.

10 The mobile station or base station shall set this field to
11 '00000'.

12 SO - Service option number.

13 The mobile station or base station shall set this field to the
14 service option number of the data service.

15 SDU_DATA - Data octets.

16 The mobile station or base station shall set this field to the
17 data included in this message.

1 2.2.2.2 Mux and QoS Sublayer

2 2.2.2.2.1 The Multiplex Sublayer

3 The multiplex sublayer has both a transmitting and a receiving function. The multiplex
 4 sublayer transmitting function combines information from various sources (e.g., Upper
 5 Layer Signaling, Data Service instances, and Voice Service) and forms Physical Layer
 6 SDUs for transmission (see Figure 5). The multiplex sublayer receiving function
 7 separates the information contained in Physical Layer SDUs, and directs the
 8 information to the correct entity (e.g., Upper Layer Signaling, Data Service instances, or
 9 Voice Service).

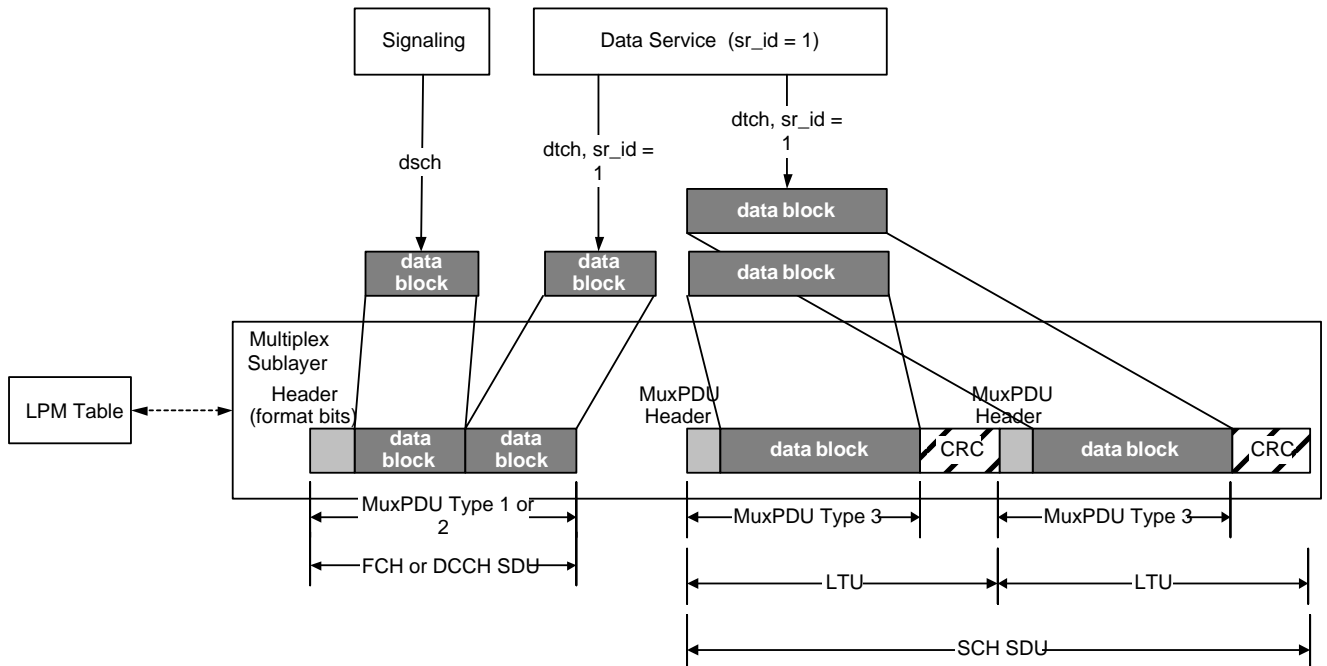

10
11

12 **Figure 5. Overview of the Multiplex Sublayer Transmitting Function.**

13 The multiplex sublayer operates in one of the following two modes:

- 14 • Mode A is used when operating radio configuration less than or equal to 2 with a
 15 TIA/EIA-95-B Physical Layer; and
- 16 • Mode B is used when operating with a radio configuration greater than 2 with a
 17 IS-639 Physical Layer.

18 The multiplex sublayer has both a transmitting and a receiving function.

1 The transmitting function, under QoS control,⁶ solicits information bits from signaling
 2 and connected services or from logical channels. Information bits are exchanged
 3 between signaling and the multiplex sublayer using the primitives described in
 4 2.2.2.2.1.6; the multiplex sublayer converts the information bits received from signaling
 5 into a data block. Information bits are exchanged between a connected service or a
 6 logical channel and the multiplex sublayer in a unit called a data block. The multiplex
 7 sublayer multiplexes one or more data blocks into a MuxPDU and combines one or
 8 more MuxPDUs into a Physical Layer SDU for transmission by the Physical Layer.
 9 Physical layer SDUs are exchanged between the multiplex sublayer and the Physical
 10 Layer using the service interface operations in 2.2.2.2.1.7.

11 There is a single MuxPDU in each Physical Layer FCH or DCCH SDU. Table 17 and
 12 Table 18 detail the data block combinations allowed in the MuxPDU that forms a 20 ms
 13 Physical Layer FCH or DCCH SDU. As shown in Table 20, only a single data block is in
 14 the MuxPDU that is used to form a 5 ms Physical Layer FCH or DCCH SDU. Table 6
 15 lists the various multiplex options used with the FCH or DCCH.

16 **Table 6. Multiplex Options Applicable to a FCH or DCCH**

	Multiplex Option	
	Rate Set 1	Rate Set 2
FCH	0x1	0x2
DCCH	0x1	0x2

17
 18 When operating in Mode A, one MuxPDU is used to form each Physical Layer SCCH
 19 SDU. Each MuxPDU used contains a single data block. Table 7 lists the various
 20 multiplex options used with SCCHs.

21 **Table 7. Multiplex Options Applicable to SCCHs**

Maximum Number of SCCHs	Maximum Number of MuxPDUs	Multiplex Option	
		Rate Set 1	Rate Set 2
1	1	0x3	0x4
2	2	0x5	0x6
3	3	0x7	0x8
4	4	0x9	0xa
5	5	0xb	0xc
6	6	0xd	0xe
7	7	0xf	0x10

22
 23 When operating in Mode B, one or more MuxPDUs are used to form a Physical Layer
 24 SCH SDU. Each MuxPDU used contains a single data block. The multiplex option
 25 associated with the SCH defines both the number of MuxPDUs in the SDU and defines
 26 the size of the data block in each MuxPDU. Table 8 lists the various multiplex options
 27 used with the SCH, and Table 19 lists the allowed data block sizes. For Table 8, each
 28 odd-numbered multiplex option also implies that multiplex option 0x1 is used on the
 29 FCH or DCCH. Each even-numbered multiplex option also implies that multiplex option
 30 0x2 is used on the FCH or DCCH.

31 **Table 8. Multiplex Options Applicable to an SCH**

⁶ When operating in Mode A, the multiplex sublayer assigns relative service priority (see 2.2.2.2.1.2)

1

SCH Rate	Maximum Number of MuxPDUs in the Physical Layer SDU			Multiplex Option					
				Rate Set 1			Rate Set 2		
	MuxPDU Type 1 or 2	MuxPDU Type 3 single double		MuxPDU Type 1	MuxPDU Type 3 single double		MuxPDU Type 2	MuxPDU Type 3 single double	
1x	1			0x03			0x04		
2x		2	1		0x809	0x905		0x80a	0x906
4x		4	2		0x811	0x909		0x812	0x90a
8x		8	4		0x821	0x911		0x822	0x912
16x			8			0x921			0x922

2 Note: SCH Rate is expressed in multiples of a base rate. For Rate Set 1, the base rate is
 3 9600 bps, and for Rate Set 2, the base rate is 14400 bps. Thus a 2x SCH rate means
 4 twice 9600 for Rate Set 1 (19200), or twice 14400 for Rate Set 2 (28800).

5

6 The multiplex sublayer derives the multiplex option in use for the SCH based upon the
 7 configured multiplex option and the current SCH rate. If the configured multiplex
 8 option is 0x809, 0x811, 0x821, 0x905, 0x909, 0x911, 0x921, 0x80a, 0x812, 0x822,
 9 0x906, 0x90a, 0x912, or 0x922 and the For-SCH Rate is 1x, the multiplex option in use
 10 is 0x3 when the configured multiplex option is odd-numbered, and is 0x4 when the
 11 configured multiplex option is even-numbered. For SCH Rate 2x and higher, the
 12 multiplex option in use is specified by the column in Table 8 containing the configured
 13 multiplex option and the row in Table 8 corresponding to the current SCH rate.

14 For multiplex options greater than 0x10, Table 9 describes the fields used to compute
 15 the multiplex option number.

16 **Table 9. Fields Used to Compute Multiplex Option Numbers Greater than 0x10**

Field Name	Number of Bits	Value	
Rate_Set	2	'01' - Rate Set 1 '10' - Rate Set 2	Least Significant Bit
Max_Data_Blocks	6	'000001' - '001000'	
Data_Block_Size	2	'00' - Single size '01' - Double size	
MuxPDU_Type	2	'00' - MuxPDU Types 1, 2, or 4 '10' - MuxPDU Type 3	Most Significant Bit
Format_Descriptor	4	'0000' - Format 1	

17

18 The receiving function accepts a Physical Layer SDU, divides it into one or more
 19 MuxPDUs, demultiplexes the data blocks in each MuxPDU and delivers the information
 20 bits to the appropriate service.

21 The information bits in a signaling data block are also called signaling traffic.

22 **2.2.2.2.1 Mobile Station Support**

23 If the mobile station supports Radio Configuration 1, it shall support the FCH, and the
 24 mobile station shall support Mode A on the FCH.

25 If the mobile station supports a Radio Configuration with a number greater than 2, and
 26 if the mobile station supports a voice service option, the mobile station shall support
 27 the FCH, and the mobile station shall support Mode B on the FCH.

1 The mobile station may support Mode B on the FCH, DCCH, or SCH. If the mobile
 2 station supports a Radio Configuration with a number greater than 2, and if the mobile
 3 station supports the FCH, the mobile station shall support Mode B on the FCH.

4 The mobile station shall support multiplex option 0x1 and Rate Set 1.

5 The mobile station shall support signaling traffic and shall support Primary Traffic.

6 The mobile station shall support those MuxPDU Type 1 structures that contain
 7 signaling traffic only, primary traffic only, or both signaling and primary traffic.

8 The mobile station may support multiplex option 0x2 and Rate Set 2. If the mobile
 9 station supports multiplex option 0x2 and Rate Set 2, it shall support those MuxPDU
 10 Type 2 structures that contain signaling traffic only, primary traffic only, or both
 11 signaling and primary traffic.

12 The mobile station may support secondary traffic. If it supports secondary traffic, it
 13 shall support those MuxPDU Type 1 structures that contain secondary traffic. If the
 14 mobile station supports secondary traffic, multiplex option 0x2, and Rate Set 2, the
 15 mobile station shall also support those MuxPDU Type 2 structures that contain
 16 secondary traffic.

17 The mobile station may support one or more of multiplex options 0x3, 0x5, 0x7, 0x9,
 18 0xb, 0xd, and 0xf, in the forward direction, or in the reverse direction, or in both
 19 directions.

20 The mobile station may support one or more of multiplex options 0x4, 0x6, 0x8, 0xa,
 21 0xc, 0xe, and 0x10, in the forward direction, or in the reverse direction, or in both
 22 directions.

23 The mobile station may support one or more of multiplex options 0x809, 0x811, 0x821,
 24 0x905, 0x909, 0x911, and 0x921, in the forward direction, or in the reverse direction,
 25 or in both directions. If the mobile station supports any of these multiplex options, it
 26 shall also support Mode B.

27 The mobile station may support one or more of multiplex options 0x80a, 0x812, 0x822,
 28 0x906, 0x90a, 0x912, and 0x922, in the forward direction, or in the reverse direction,
 29 or in both directions. If the mobile station supports any of these multiplex options, it
 30 shall also support Mode B.

31 The mobile station may support MuxPDU Type 4.

32 **2.2.2.2.1.2 Default Service Priority**

33 The multiplex sublayer may determine the relative priority between traffic supplied
 34 by Signaling and other services using the information provided by the parameters in
 35 the MAC-SDUReady.Request () primitive. The exact manner for using this
 36 information to deliver over-the-air Quality of Service is not specified by this
 37 standard.

38 **2.2.2.2.1.3 Multiplex Sublayer Transmitting Function**

39 **2.2.2.2.1.3.1 Assembling the Physical Layer FCH SDU for Transmission**

40 **2.2.2.2.1.3.1.1 Mode A**

41 If an FCH physical channel has been assigned, the multiplex sublayer shall assemble a
 42 Physical Layer FCH SDU every 20 ms. The multiplex sublayer shall combine available
 43 data blocks from signaling and all connected services, according to the relative priority
 44 of each, to form a MuxPDU.

1 If the FCH physical channel is used with Rate Set 1, the multiplex sublayer shall use
2 the supplied data blocks to form a MuxPDU Type 1, as specified in 2.2.2.2.1.5.

3 If the FCH physical channel is used with Rate Set 2, the multiplex sublayer shall use
4 the supplied data blocks to form a MuxPDU Type 2, as specified in 2.2.2.2.1.5.

5 If signaling and all services supply Blank data blocks, the multiplex sublayer shall
6 create a null traffic MuxPDU. A null traffic MuxPDU contains only the lowest negotiated
7 transmit rate primary traffic data block with all bits set to '1'.

8 The multiplex sublayer shall deliver the assembled Physical Layer SDU to the Physical
9 Layer using the *Transmit FCH Request* service interface operation in accordance with
10 2.2.2.2.1.7.1.

11 **2.2.2.2.1.3.1.2 Mode B**

12 If an FCH physical channel has been assigned, the multiplex sublayer shall assemble a
13 Physical Layer FCH SDU at the beginning of every 20 ms interval. The multiplex
14 sublayer shall not assemble a 20 ms FCH SDU at any time other than the beginning of
15 a 20 ms interval. ~~The multiplex sublayer may form a MuxPDU Type 4 every 5 ms~~
16 assemble a 5 ms FCH SDU at the beginning of any 5 ms interval. See the procedures
17 for Reverse Fundamental Channel Transmission Processing and Forward Fundamental
18 Channel Transmission Processing in [2] for an explanation of the puncturing of 5 ms
19 physical layer frames into 20 ms physical layer frames.

20 To assemble a 20 ms Physical Layer FCH SDU, the multiplex sublayer shall combine
21 available 20 ms data blocks from signaling and all FCH-mapped logical channels⁷,
22 according to the relative priority of each, to form a MuxPDU. The multiplex sublayer
23 shall not combine a 5 ms data block with any 20 ms data block in the same
24 MuxPDU. To assemble a 5 ms Physical Layer FCH SDU, the multiplex sublayer shall use
25 a 5 ms data block from signaling to form a MuxPDU Type 4, as specified in 2.2.2.2.1.5.

26 If signaling supplies a 5 ms data block at the beginning of a 20 ms interval, the
27 multiplex sublayer shall assemble a 5 ms FCH SDU using the supplied 5 ms data block.
28 If the multiplex sublayer does not also assemble a 20 ms FCH SDU at the beginning of
29 the same 20 ms interval, then every 5 ms interval thereafter, until the beginning of the
30 next 20 ms interval, the multiplex sublayer shall perform the following:~~perform the~~
31 ~~following:~~

- 32 ● If signaling supplies a 5 ms data block at the beginning of the interval, the multiplex
33 sublayer shall assemble a 5 ms FCH SDU.~~If the multiplex sublayer does not~~
34 ~~assemble a 20 ms FCH SDU in the same 20 ms interval, the multiplex sublayer~~
35 ~~shall require all other FCH-mapped logical channels to supply a Blank data block.~~
36 ~~The multiplex sublayer shall use the supplied 5 ms data block to form a MuxPDU~~
37 ~~Type 4, as specified in 2.2.2.2.1.5. The multiplex sublayer shall form a MuxPDU~~
38 ~~Type 4 or Null MuxPDU every 5 ms thereafter until the beginning of the next 20 ms~~
39 ~~interval.~~
- 40 ● If signaling does not supply a 5 ms data block at the beginning of the interval, the
41 multiplex sublayer shall assemble a Null MuxPDU.~~If the multiplex sublayer~~
42 ~~assembles a 20 ms FCH SDU in the same 20 ms interval, the multiplex sublayer~~
43 ~~shall use the supplied 5 ms data block to form a MuxPDU Type 4, as specified in~~
44 ~~2.2.2.2.1.5, and also assemble a 20 ms FCH SDU in the same 20 ms interval.~~

⁷ The Logical-to-Physical Mapping Table specifies the mapping of logical channels to physical channels.

1 If signaling supplies a 5 ms data block at any time other than the beginning of a 20 ms
 2 interval, the multiplex sublayer shall ~~assemble a 5 ms FCH SDU, use the supplied 5 ms~~
 3 ~~data block to form a MuxPDU Type 4, according to Table 20.~~

4 ~~After any FCH-mapped logical channel supplies a non-Blank 20 ms data block, the~~
 5 ~~multiplex sublayer shall not accept a 5 ms data block for the MuxPDU being assembled.~~

6 If the FCH physical channel is used with Rate Set 1, the multiplex sublayer shall use
 7 the supplied 20 ms data blocks to form a MuxPDU Type 1, as specified in 2.2.2.2.1.5.

8 If the FCH physical channel is used with Rate Set 2, the multiplex sublayer shall use
 9 the supplied 20 ms data blocks to form a MuxPDU Type 2, as specified in 2.2.2.2.1.5.

10 If, at the beginning of a 20 ms interval, signaling and all FCH-mapped logical channels
 11 supply Blank data blocks, the multiplex sublayer shall assemble a 20 ms FCH SDU by
 12 creating ~~create~~ a null traffic MuxPDU, as specified in 2.2.2.2.1.5. A null traffic
 13 MuxPDU contains only the lowest negotiated transmit rate primary traffic data block
 14 with all bits set to '1'.

15 The multiplex sublayer shall deliver the assembled Physical Layer FCH SDU or SDUs to
 16 the Physical Layer using the *Transmit FCH Request* service interface operation in
 17 accordance with 2.2.2.2.1.7.1.

18 2.2.2.2.1.3.2 Assembling the Physical Layer DCCH SDU for Transmission

19 2.2.2.2.1.3.2.1 Mode B

20 If a DCCH physical channel has been assigned, the multiplex sublayer shall assemble a
 21 Physical Layer DCCH SDU at the beginning of every 20 ms interval. The multiplex
 22 sublayer shall not assemble a 20 ms DCCH SDU at any time other than the beginning
 23 of a 20 ms interval. ~~The multiplex sublayer may assemble a 5 ms DCCH SDU at the~~
 24 ~~beginning of any 5 ms interval. See the procedures for Reverse Dedicated Control~~
 25 ~~Channel Transmission Processing and Forward Dedicated Control Channel~~
 26 ~~Transmission Processing in [2] for an explanation of the puncturing of 5 ms physical~~
 27 ~~layer frames into 20 ms physical layer frames form a MuxPDU Type 4 every 5 ms. If, at~~
 28 ~~the beginning of a 20 ms interval, PILOT_GATING_USE_RATE is not equal to '0', then~~
 29 ~~the multiplex sublayer shall require all DCCH-mapped logical channels, other than~~
 30 ~~signaling, to supply a 20 ms Blank data block.~~

31 To assemble a 20 ms physical layer DCCH SDU, the multiplex sublayer shall combine
 32 available 20 ms data blocks from signaling and all DCCH-mapped logical channels,
 33 according to the relative priority of each, to form a MuxPDU. The multiplex sublayer
 34 shall not combine a 5 ms data block with any 20 ms data block in the same MuxPDU.
 35 To assemble a 5 ms Physical Layer DCCH SDU, the multiplex sublayer shall use a 5 ms
 36 data block from signaling to form a MuxPDU Type 4, as specified in 2.2.2.2.1.5. ~~perform~~
 37 ~~the following:~~

38 ~~—If PILOT_GATING_USE_RATE is equal to '0', then the multiplex sublayer shall combine~~
 39 ~~available data blocks from signaling and all DCCH-mapped logical channels,~~
 40 ~~according to the relative priority of each, to form a MuxPDU.~~

41 ~~—Otherwise, if PILOT_GATING_USE_RATE is not equal to '0', then the multiplex~~
 42 ~~sublayer shall form a MuxPDU from the available data block from signaling.~~

43 ~~If signaling supplies a 5 ms data block at the beginning of a 20 ms interval, the~~
 44 ~~multiplex sublayer shall perform the following:~~

~~If the multiplex sublayer does not assemble a 20 ms DCCH SDU in the same 20 ms interval, the multiplex sublayer shall require all other DCCH-mapped logical channels to supply a Blank data block. The multiplex sublayer shall use the supplied 5 ms data block to form a MuxPDU Type 4, as specified in 2.2.2.2.1.5. The multiplex sublayer shall form a MuxPDU Type 4 or Null MuxPDU every 5 ms thereafter until the beginning of the next 20 ms interval.~~

~~If the multiplex sublayer assembles a 20 ms DCCH SDU in the same 20 ms interval, the multiplex sublayer shall use the supplied 5 ms data block to form a MuxPDU Type 4, as specified in 2.2.2.2.1.5, and also assemble a 20 ms DCCH SDU in the same 20 ms interval.~~

~~If signaling supplies a 5 ms data block at any time other than the beginning of a 20 ms interval, the multiplex sublayer shall use the supplied 5 ms data block to form a MuxPDU Type 4, according to Table 20.~~

~~After any DCCH-mapped logical channel supplies a non-blank 20 ms data block, the multiplex sublayer shall not accept a 5 ms data block for the MuxPDU being assembled.~~

If the DCCH physical channel is used with Rate Set 1, the multiplex sublayer shall use the supplied 20 ms data blocks to form a MuxPDU Type 1, as specified in 2.2.2.2.1.5.

If the DCCH physical channel is used with Rate Set 2, the multiplex sublayer shall use the supplied 20 ms data blocks to form a MuxPDU Type 2, as specified in 2.2.2.2.1.5.

If, at the beginning of a 20 ms interval, signaling supplies a 20 ms Blank data block, and all other DCCH-mapped logical channels supply either a 20 ms Blank data block or an idle category 20 ms data block,⁸ the multiplex sublayer shall assemble a 20 ms DCCH SDU by creating a Null MuxPDU.

The multiplex sublayer shall deliver the assembled Physical Layer DCCH SDU or SDUs to the Physical Layer using the *Transmit DCCH Request* service interface operation in accordance with 2.2.2.2.1.7.2.

2.2.2.2.1.3.3 Assembling the Physical Layer SCCH SDU for Transmission

2.2.2.2.1.3.3.1 Mode A

For each SCCH (Supplemental Code Channel) that has been assigned, the multiplex sublayer shall assemble a Physical Layer SCCH SDU every 20 ms. The multiplex sublayer shall form a MuxPDU using a single data block from a connected service, requesting the data block from each connected service in order of the relative priority of each connected service.

If all connected services supply Blank data blocks, the multiplex sublayer shall create a Null MuxPDU.

If a connected service supplies a non-Blank data block and if the SCCH is used with Rate Set 1, the multiplex sublayer shall use the supplied data block to form a MuxPDU Type 1, as specified in 2.2.2.2.1.5.

If a connected service supplies a non-Blank data block and if the SCCH is used with Rate Set 2, the multiplex sublayer shall use the supplied data block to form a MuxPDU Type 2, as specified in 2.2.2.2.1.5.

⁸ A data service option may indicate a data block's category when it supplies the data block to the multiplex sublayer.

1 The multiplex sublayer shall deliver the assembled Physical Layer SCCH SDU to the
 2 Physical Layer using the *Transmit SCCH Request* service interface operation in
 3 accordance with 2.2.2.2.1.7.3.

4 **2.2.2.2.1.3.3.2 Procedures for Adding and Dropping R-SCCHs**

5 Whenever the ~~Multiplex Sublayer~~multiplex sublayer is delivering MuxPDUs of Type 1 or
 6 2 for i R-SCCHs, the ~~Multiplex Sublayer~~multiplex sublayer shall deliver a MuxPDU of
 7 Type 1 or 2 for each R-SCCH with code channel indices 1 to i . If the ~~Multiplex~~
 8 ~~Sublayer~~multiplex sublayer reduces the number of R-SCCHs on which it is delivering
 9 MuxPDUs of Type 1 or 2 (e.g., due to transmitter power limitations, lack of data to
 10 transmit, or when fewer R-SCCHs are allocated), the ~~Multiplex Sublayer~~multiplex
 11 ~~sublayer~~ shall discontinue delivering MuxPDUs of Type 1 or 2 to the Physical Layer for
 12 R-SCCHs with the highest code channel indices first.

13 If REV_DTX_DURATION_S is not equal to '1111' and the ~~Multiplex Sublayer~~multiplex
 14 ~~sublayer~~ stops delivering MuxPDUs of Type 1 or 2 to the Physical Layer for an R-SCCH
 15 for a period of time longer than REV_DTX_DURATION_S × 20 ms, then the ~~Multiplex~~
 16 ~~Sublayer~~multiplex sublayer shall not resume delivering MuxPDUs of Type 1 or 2 to the
 17 Physical Layer for that R-SCCH until that R-SCCH is re-allocated. Similarly, if the
 18 ~~Multiplex Sublayer~~multiplex sublayer increases the number of MuxPDUs of Type 1 or 2
 19 that are sent to the Physical Layer for R-SCCHs that are in use from j to $j + 1$ (e.g., due
 20 to resumption of transmission when discontinuous transmission is permitted, or when
 21 additional R-SCCHs are allocated), the ~~Multiplex Sublayer~~multiplex sublayer shall begin
 22 to deliver MuxPDUs of Type 1 or 2 for an R-SCCH with code channel index $j + 1$ before
 23 delivering MuxPDUs of Type 1 or 2 for code channels with any larger index.

24 **2.2.2.2.1.3.3.3 Procedures for the R-SCCH Transmission Preamble**

- 25 • Whenever the ~~Multiplex Sublayer~~multiplex sublayer begins to deliver MuxPDUs of
 26 Type 1 or 2 to the Physical Layer for an R-SCCH following one or more Null
 27 MuxPDUs for the first time after the allocation of the R-SCCH, the ~~Multiplex~~
 28 ~~Sublayer~~multiplex sublayer shall send a *Transmit R-SCCH Preamble Request* with
 29 NUM_PREAMBLE_FRAMES set to BEGIN_PREAMBLE_S.

30 **2.2.2.2.1.3.3.4 Procedures for the R-SCCH Discontinuous Transmission** 31 **(DTX) Preamble**

32 If the currently connected service option permits discontinuous R-SCCH transmission,
 33 then the ~~Multiplex Sublayer~~multiplex sublayer may resume delivering MuxPDUs of Type
 34 1 or 2 to the Physical Layer for an R-SCCH following one or more Null MuxPDUs for
 35 that R-SCCH. When the ~~Multiplex Sublayer~~multiplex sublayer resumes delivering
 36 MuxPDUs of Type 1 or 2 for an R-SCCH, the ~~Multiplex Sublayer~~multiplex sublayer shall
 37 indicate to the Physical Layer that the Discontinuous Transmission preamble is to be
 38 transmitted on the R-SCCH by sending a *Transmit R-SCCH Preamble Request* to the
 39 Physical Layer with NUM_PREAMBLE_FRAMES set to RESUME_PREAMBLE_S.

40 The ~~Multiplex Sublayer~~multiplex sublayer shall not indicate that the Supplemental
 41 Code Channel Discontinuous Transmission preamble is to be transmitted by the
 42 Physical Layer when the ~~Multiplex Sublayer~~multiplex sublayer begins to deliver
 43 MuxPDUs of Type 1 or 2 for an R-SCCH following the allocation of that R-SCCH.

1 **2.2.2.2.1.3.4 Assembling the Physical Layer SCH SDU for Transmission**

2 **2.2.2.2.1.3.4.1 Mode B**

3 For each SCH that has been assigned, the multiplex sublayer shall assemble a Physical
4 Layer SCH SDU every 20 ms. The multiplex sublayer shall form each MuxPDU using a
5 single data block from a SCH-mapped logical channel. The multiplex sublayer shall
6 request data blocks from the SCH-mapped logical channels, according to the relative
7 priority of each logical channel, until enough data blocks have been supplied to form
8 the number of MuxPDUs needed to fill the SCH SDU, or all SCH-mapped logical
9 channels have supplied all available data blocks. The multiplex sublayer shall indicate
10 the multiplex option in use when it requests data blocks from the SCH-mapped logical
11 channels.

12 If all SCH-mapped logical channels supply a Blank data block, the multiplex sublayer
13 shall create a single Null MuxPDU and shall consider assembly of this Physical Layer
14 SCH SDU completed.

15 If the SCH multiplex option in use is 0x3, the multiplex sublayer shall use the supplied
16 non-Blank data block to form a MuxPDU Type 1, as specified in 2.2.2.2.1.5.

17 If the SCH multiplex option in use is 0x4, the multiplex sublayer shall use the supplied
18 non-Blank data block to form a MuxPDU Type 2, as specified in 2.2.2.2.1.5.

19 If the SCH multiplex option in use is greater than 0x10, the multiplex sublayer shall
20 use each supplied non-Blank data block to form a MuxPDU Type 3, as specified in
21 2.2.2.2.1.5. If the Physical Layer uses convolutional coding for the SCH during
22 transmission of the Physical Layer frame containing the SDU, and if Table 10 indicates
23 a non-zero number of LTUs in the SDU, the multiplex sublayer shall assemble the
24 Physical Layer SCH SDU using LTUs, according to 2.2.2.2.1.3.4.1.1. Otherwise, the
25 multiplex sublayer shall insert the MuxPDUs serially into the Physical Layer SCH SDU.
26 If the number of inserted MuxPDUs is less than the number of MuxPDUs required by
27 the multiplex option for the SCH (see Table 8), then the multiplex sublayer shall insert
28 one Fill MuxPDU containing a data block of the size indicated by the multiplex option
29 associated with the SCH, filled with '0' bits. The multiplex sublayer shall fill any
30 remaining space in the SCH SDU with '0' bits.

31 The multiplex sublayer shall deliver the assembled Physical Layer SCH SDU to the
32 Physical Layer using the *Transmit SCH Request* service interface operation in
33 accordance with 2.2.2.2.1.7.4.

34 **2.2.2.2.1.3.4.1.1 LTU Assembly**

35 The multiplex sublayer shall combine Type 3 MuxPDUs into LTUs according to Table
36 10. Each LTU shall contain a 16-bit CRC and either 2 MuxPDUs that contain a single
37 size non-Blank data block or 1 MuxPDU that contains a double size non-Blank data
38 block. If there are not enough supplied MuxPDUs to fill every LTU in the Physical Layer
39 SCH SDU, the multiplex sublayer shall insert enough Fill MuxPDUs into each LTU that
40 is not full, so as to fill the LTU. Each Fill MuxPDU shall contain a data block filled with
41 '0' bits, of the size indicated by the multiplex option associated with the SCH. The
42 multiplex sublayer shall calculate a 16-bit CRC on all bits in the LTU, except the CRC,
43 and shall insert the CRC following the MuxPDUs in the LTU. The CRC shall be
44 calculated using the procedure used to calculate the 16-bit SCH frame quality
45 indicator. The multiplex sublayer shall insert the LTUs serially into the Physical Layer
46 SCH SDU and shall fill any remaining space in the Physical Layer SCH SDU with '0'
47 bits.

1

Table 10. Number of LTUs in an SCH Physical Layer SDU

SDU Transmit Rate (bits/sec)	Number of LTUs in the SDU
9600	0
19200	0
38400	2
76800	4
153600	8
14400	0
28800	0
57600	2
115200	4
230400	8

2

2.2.2.2.1.3.4.2 Procedures for ~~Reverse~~ Discontinuous Transmission (DTX) on the R-SCH

3

4

If REV_DTX_DURATION_S is not equal to '1111' and the ~~Multiplex Sublayer~~multiplex sublayer delivers consecutive Null MuxPDUs to the Physical Layer for a period of time longer than REV_DTX_DURATION_S × 20 ms, then the ~~Multiplex Sublayer~~multiplex sublayer shall not resume delivering MuxPDUs of Type 1, 2, or 3 to the Physical Layer for that R-SCH until the R-SCH is re-allocated by the base station.

5

6

7

8

9

If REV_DTX_DURATION_S is equal to '1111', the ~~Multiplex Sublayer~~multiplex sublayer may resume delivering MuxPDUs of Type 1, 2, or 3 to the Physical Layer for the R-SCH at any time that the R-SCH is allocated.

10

11

1 **2.2.2.2.1.4 Multiplex Sublayer Receiving Function**

2 The Physical Layer delivers a Physical Layer SDU to the multiplex sublayer using a
3 physical channel specific *Receive Indication* service interface operation.

4 The mobile station's multiplex sublayer shall categorizes each MuxPDU in each received
5 Physical Layer SDU and shall supplyies the category when it delivers a data block from
6 the SDU to the logical channel. Table 11 lists the categories associated with each
7 MuxPDU Type 1 that may be received on the FCH or DCCH. Table 12 lists the
8 categories associated with each MuxPDU Type 2 that may be received on the FCH or
9 DCCH. Table 13 lists the categories associated with each MuxPDU Type 4 that may be
10 received on the FCH or DCCH. Table 14 lists the categories associated with each
11 MuxPDU Type 1 that may be received on a SCCH or a SCH operating at 9600 bps. Table
12 15 lists the categories associated with each MuxPDU Type 2 that may be received on a
13 SCCH or SCH operating at 14400 bps. Table 16 lists the categories associated with each
14 MuxPDU Type 3 that may be received on a SCH operating at rate 2x or higher.

1
2**Table 11. Received MuxPDU Type 1 Categories and Formats for the FCH and DCCH**

Category	MuxPDU Header or Frame Description			Primary Traffic (bits/block)	Signaling Traffic (bits/block)	Secondary Traffic (bits/block)	Applies to	
	Mixed Mode (MM)	Traffic Type (TT)	Traffic Mode (TM)				FCH	DCCH
1	'0'	-	-	171	0	0	Y	Y
2	'1'	'0'	'00'	80	88	0	Y	Y
3	'1'	'0'	'01'	40	128	0	Y	Y
4	'1'	'0'	'10'	16	152	0	Y	Y
5	'1'	'0'	'11'	0	168	0	Y	Y
6	-	-	-	80	0	0	Y	N
7	-	-	-	40	0	0	Y	N
8	-	-	-	16	0	0	Y	N
9	9600 bps Physical Layer frame with insufficient Physical Layer frame quality ⁹			0	0	0	Y	Y
10	i nsufficient Physical Layer frame quality ¹⁰			0	0	0	Y	Y
11	'1'	'1'	'00'	80	0	88	Y	Y
12	'1'	'1'	'01'	40	0	128	Y	Y
13	'1'	'1'	'10'	16	0	152	Y	Y
14	'1'	'1'	'11'	0	0	168	Y	Y
15	n Null Physical Layer frame			0	0	0	N	Y

3

⁹ This category is used when the Physical Layer frame quality is insufficient, but other parameters indicate a 9600 bps frame has been received.

¹⁰ This category is used when the Physical Layer frame's bit rate cannot be determined or when the error does not belong to category 9.

1
2**Table 12. Received MuxPDU Type 2 Categories and Formats for the FCH and DCCCH**

Category	MuxPDU Header or Frame Description		Primary Traffic (bits/block)	Signaling Traffic (bits/block)	Secondary Traffic (bits/block)	Applies to	
	Mixed Mode (MM)	Frame Mode (FM)				FCH	DCCCH
1	'0'	-	266	0	0	Y	Y
2	'1'	'0000'	124	138	0	Y	Y
3	'1'	'0001'	54	208	0	Y	Y
4	'1'	'0010'	20	242	0	Y	Y
5	'1'	'0011'	0	262	0	Y	Y
6	'1'	'0100'	124	0	138	Y	Y
7	'1'	'0101'	54	0	208	Y	Y
8	'1'	'0110'	20	0	242	Y	Y
9	'1'	'0111'	0	0	262	Y	Y
10	'1'	'1000'	20	222	20	Y	Y
11	'0'	-	124	0	0	Y	N
12	'1'	'000'	54	67	0	Y	N
13	'1'	'001'	20	101	0	Y	N
14	'1'	'010'	0	121	0	Y	N
15	'1'	'011'	54	0	67	Y	N
16	'1'	'100'	20	0	101	Y	N
17	'1'	'101'	0	0	121	Y	N
18	'1'	'110'	20	81	20	Y	N
19	'0'	-	54	0	0	Y	N
20	'1'	'00'	20	32	0	Y	N
21	'1'	'01'	0	52	0	Y	N
22	'1'	'10'	20	0	32	Y	N
23	'1'	'11'	0	0	52	Y	N
24	'0'	-	20	0	0	Y	N
25	'1'	-	0	0	20	Y	N
26	Insufficient Physical Layer frame quality ¹¹		0	0	0	Y	Y
27	Null Physical Layer frame		0	0	0	N	Y

3

¹¹ This category is used when the Physical Layer frame's bit rate cannot be determined or when errors are detected.

1 **Table 13. Received MuxPDU Type 4 Categories and Formats for the FCH and**
 2 **DCCH**

Category	MuxPDU Header or Description	Signaling Traffic (bits/block)	Applies to	
			FCH	DCCH
1	-	24	Y	Y
2	Insufficient Physical Layer frame quality	0	Y	Y

3 **Table 14. Received MuxPDU Type 1 Categories and Formats for the SCCH and**
 4 **SCH**

Category	MuxPDU Header or Frame Description			Primary Traffic (bits/block)	Signaling Traffic (bits/block)	Secondary Traffic (bits/block)
	Mixed Mode (MM)	Traffic Type (TT)	Traffic Mode (TM)			
1	'0'	-	-	171	0	0
2	'1'	'1'	'11'	0	0	168
3	Insufficient Physical Layer frame quality			0	0	0

5

1 **Table 15. Received MuxPDU Type 2 Categories and Formats for the SCCH and**
 2 **SCH**

MuxPDU Header or Frame Description					
Category	Mixed Mode (MM)	Frame Mode (FM)	Primary Traffic (bits/block)	Signaling Traffic (bits/block)	Secondary Traffic (bits/block)
1	'0'	-	266	0	0
2	'1'	'0111'	0	0	262
3	Insufficient Physical Layer frame quality		0	0	0

3 **Table 16. Received MuxPDU Type 3 Categories and Formats for the SCH**

Category	Frame Description or MuxPDU Header		Traffic (bits/block)	R S 1	R S 2
	sr_id	Reserved			
4	'001'- '110'	'000'	170	X	
			266		X
5	'001'- '110'	'000'	346	X	
			538		X
3	Insufficient Physical Layer frame quality		0	X	X

4

5 **2.2.2.2.1.4.1 Processing the Received Physical Layer FCH SDU**

6 **2.2.2.2.1.4.1.1 Mode A**

7 If a FCH physical channel has been assigned, the Physical Layer delivers a Physical
 8 Layer FCH SDU every 20 ms. Each Physical Layer FCH SDU contains at most one
 9 MuxPDU.

10 If the Physical Layer indicates the Physical Layer frame's size is 20 ms and the Physical
 11 Layer frame's quality is sufficient, the multiplex sublayer shall identify the MuxPDU in
 12 the Physical Layer SDU according to the following:

- 13 • If the FCH physical channel is used with Rate Set 1, the multiplex sublayer shall
 14 use Table 17 to identify a MuxPDU Type 1 from the set of those allowed for the FCH.
- 15 • If the FCH physical channel is used with Rate Set 2, the multiplex sublayer shall
 16 use Table 18 to identify a MuxPDU Type 2 from the set of those allowed for the FCH.

17 If the multiplex sublayer identifies a valid, non-null traffic MuxPDU, it shall deliver the
 18 signaling data block to signaling, and deliver each data block for a connected service to
 19 that service.

1 The multiplex sublayer shall deliver a Blank data block to signaling and each connected
2 service when any of the following are true:

- 3 • The Physical Layer indicates the Physical Layer frame's size is not 20 ms.
- 4 • The Physical Layer indicates the Physical Layer frame's quality is insufficient.
- 5 • The multiplex sublayer cannot identify the MuxPDU in the Physical Layer SDU, or
6 determines the MuxPDU is invalid.
- 7 • The multiplex sublayer determines it has received a null traffic MuxPDU.

8 When the multiplex sublayer delivers a data block to signaling, it shall use the
9 procedures in 2.2.2.2.1.6.

10 **2.2.2.2.1.4.1.2 Mode B**

11 If an FCH physical channel has been assigned, the Physical Layer delivers a Physical
12 Layer FCH SDU at least every 20 ms. Each Physical Layer FCH SDU contains at most
13 one MuxPDU.

14 If the Physical Layer indicates the Physical Layer frame's size is 5 ms and the Physical
15 Layer frame's quality is sufficient, the multiplex sublayer shall identify the MuxPDU in
16 the Physical Layer SDU according to Table 20. If the multiplex sublayer identifies a
17 valid MuxPDU Type 4, it shall deliver the signaling data block to signaling.

18 If the Physical Layer indicates the Physical Layer frame's size is 20 ms and the Physical
19 Layer frame's quality is sufficient, the multiplex sublayer shall identify the MuxPDU in
20 the Physical Layer SDU according to the following:

- 21 • If the FCH physical channel is used with Rate Set 1, the multiplex sublayer shall
22 use Table 17 to identify a MuxPDU Type 1 from the set of those allowed for the FCH.
- 23 • If the FCH physical channel is used with Rate Set 2, the multiplex sublayer shall
24 use Table 18 to identify a MuxPDU Type 2 from the set of those allowed for the FCH.

25 If the multiplex sublayer identifies a valid, non-null traffic 20 ms MuxPDU, it shall
26 deliver the signaling data block to signaling and shall deliver each data block for a
27 FCH-mapped logical channel to that logical channel. If the Physical Layer indicates that
28 the Physical Layer frame's bit rate is less than the negotiated maximum bit rate, the
29 mobile station's multiplex sublayer shall set the multiplex format indicator to the
30 MuxPDU category (e.g., from Table 11 or Table 12), and shall set the category for the
31 MuxPDU to the MuxPDU category associated with ~~use the~~ null Physical Layer frame
32 category¹² and shall supply the multiplex format indicator in addition to the category
33 when it delivers a Blank data block to a FCH-mapped logical channel.

34 The multiplex sublayer shall deliver a Blank data block to signaling and to each
35 FCH-mapped logical channel when any one or more of the following is true:

- 36 • The Physical Layer indicates the Physical Layer frame's size is not 5 ms or 20 ms.
- 37 • The Physical Layer indicates the Physical Layer frame's quality is insufficient.
- 38 • The multiplex sublayer cannot identify the MuxPDU in the Physical Layer SDU, or
39 determines the MuxPDU is invalid.

¹² This category indicates that a service had an opportunity to send information but did not, and may be used by the service to advance retransmission timers.

- 1 • The multiplex sublayer determines it has received a null traffic MuxPDU.
 2 When the multiplex sublayer delivers a data block to signaling, it shall use the
 3 procedures in 2.2.2.2.1.6.

4 **2.2.2.2.1.4.2 Processing the Received Physical Layer DCCH SDU**

5 **2.2.2.2.1.4.2.1 Mode B**

6 If a DCCH physical channel has been assigned, the Physical Layer delivers a Physical
 7 Layer DCCH SDU at least every 20 ms. Each Physical Layer DCCH SDU contains at
 8 most one MuxPDU.

9 If the Physical Layer indicates no-frame-received, the multiplex sublayer shall perform
 10 the following:

- 11 • If PILOT_GATING_USE_RATE is equal to '0', then the multiplex sublayer shall
 12 deliver a Blank data block to signaling and to each DCCH-mapped logical channel;
 13 the mobile station's multiplex sublayer shall use the null Physical Layer frame
 14 category¹³ when it delivers a Blank data block to a DCCH-mapped logical channel.
 15 • Otherwise, if PILOT_GATING_USE_RATE is not equal to '0', then the multiplex
 16 sublayer shall deliver a Blank data block to signaling.

17

18 If the Physical Layer indicates the Physical Layer frame's size is 5 ms and the Physical
 19 Layer frame's quality is sufficient, the multiplex sublayer shall identify the MuxPDU in
 20 the Physical Layer SDU according to Table 20. If the multiplex sublayer identifies a
 21 valid MuxPDU Type 4, it shall deliver the signaling data block to signaling.

22 If the Physical Layer indicates the Physical Layer frame's size is 20 ms and the Physical
 23 Layer frame's quality is sufficient, the multiplex sublayer shall identify the MuxPDU in
 24 the Physical Layer SDU according to the following:

- 25 • If the DCCH physical channel is used with Rate Set 1, the multiplex sublayer shall
 26 use Table 17 to identify a MuxPDU Type 1 from the set of those allowed for the
 27 DCCH.
 28 • If the DCCH physical channel is used with Rate Set 2, the multiplex sublayer shall
 29 use Table 18 to identify a MuxPDU Type 2 from the set of those allowed for the
 30 DCCH.

31 If the multiplex sublayer identifies a valid, non-null traffic 20 ms MuxPDU, it shall
 32 deliver the signaling data block to signaling, and shall deliver each data block for a
 33 DCCH-mapped logical channel to that logical channel.

34 The multiplex sublayer shall deliver a Blank data block to signaling when any one or
 35 more of the following is true:

- 36 • The Physical Layer indicates that the Physical Layer frame's size is unknown.
 37 • The Physical Layer indicates that the Physical Layer frame's quality is insufficient.

¹³ This category indicates that a service had an opportunity to send information but did not, and may be used by the service to advance retransmission timers.

- 1 ● The multiplex sublayer cannot identify the MuxPDU in the Physical Layer SDU, or
2 determines if the MuxPDU is invalid.

3 The multiplex sublayer shall deliver a Blank data block to each DCCH-mapped logical
4 channel when PILOT_GATING_USE_RATE is equal to '0' and any one or more of the
5 following is true:

- 6 ● The Physical Layer indicates that the Physical Layer frame's size is unknown.
7 ● The Physical Layer indicates that the Physical Layer frame's quality is insufficient.
8 ● The multiplex sublayer cannot identify the MuxPDU in the Physical Layer SDU, or
9 determines if the MuxPDU is invalid.

10 When the multiplex sublayer delivers a data block to signaling, it shall use the
11 procedures in 2.2.2.2.1.6.

12 **2.2.2.2.1.4.3 Processing the Received Physical Layer SCCH SDU**

13 **2.2.2.2.1.4.3.1 Mode A**

14 For each assigned SCCH physical channel, the Physical Layer delivers a Physical Layer
15 SCCH SDU every 20 ms. Each Physical Layer SCCH SDU contains at most one
16 MuxPDU.

17 If the Physical Layer indicates the Physical Layer frame's size is 20 ms and the Physical
18 Layer frame's quality is sufficient, the multiplex sublayer shall identify the MuxPDU in
19 the Physical Layer SDU according to the following:

- 20 ● If the SCCH physical channel is used with Rate Set 1, the multiplex sublayer shall
21 use Table 17 to identify a MuxPDU Type 1 from the set of those allowed for the
22 SCCH.
23 ● If the SCCH physical channel is used with Rate Set 2, the multiplex sublayer shall
24 use Table 18 to identify a MuxPDU Type 2 from the set of those allowed for the
25 SCCH.

26 If the multiplex sublayer identifies a valid MuxPDU, it shall deliver each data block for a
27 connected service to that service.

28 The multiplex sublayer shall deliver a Blank data block to each connected service when
29 one or more of the following is true:

- 30 ● The Physical Layer indicates the Physical Layer frame's size is not 20 ms.
31 ● The Physical Layer indicates the Physical Layer frame's quality is insufficient.
32 ● The multiplex sublayer cannot identify the MuxPDU in the Physical Layer SDU, or it
33 determines that the MuxPDU is invalid.

34 **2.2.2.2.1.4.4 Processing the Received Physical Layer SCH SDU**

35 **2.2.2.2.1.4.4.1 Mode B**

36 For each assigned SCH physical channel, the Physical Layer delivers a Physical Layer
37 SCH SDU every 20 ms. Each Physical Layer SCH SDU contains one or more MuxPDUs.

38 The multiplex sublayer shall process the Physical Layer SDU according to
39 2.2.2.2.1.4.4.1.2 when all of the following are true:

- 1 ● the SCH multiplex option in use is greater than 0x10,
 - 2 ● the Physical Layer indicates the Physical Layer frame's size is 20 ms,
 - 3 ● the Physical Layer used convolutional coding for the SCH during transmission of the
 - 4 Physical Layer frame, and
 - 5 ● Table 10 indicates a non-zero number of LTUs in the SDU.
- 6 Otherwise, the multiplex sublayer shall process the Physical Layer SDU according to
- 7 2.2.2.2.1.4.4.1.1.

8 **2.2.2.2.1.4.4.1.1 Non-LTU Processing**

9 If the Physical Layer indicates the Physical Layer frame's size is 20 ms and the Physical
 10 Layer frame's quality is sufficient, the multiplex sublayer shall identify the MuxPDUs in
 11 the Physical Layer SDU according to the following:

- 12 ● If the SCH multiplex option in use is 0x3, the mux sublayer shall use Table 17 to
- 13 identify each MuxPDU Type 1 from the set of those allowed for the SCH.
- 14 ● If the SCH multiplex option in use is 0x4, the mux sublayer shall use Table 18 to
- 15 identify each MuxPDU Type 2 from the set of those allowed for the SCH.
- 16 ● If the SCH multiplex option in use is greater than 0x10, the multiplex sublayer shall
- 17 use Table 19 to identify each MuxPDU Type 3.

18 For each valid MuxPDU Type 1 or MuxPDU Type 2, the multiplex sublayer shall deliver
 19 each data block for an SCH-mapped logical channel to that logical channel. For each
 20 valid, non-Fill MuxPDU Type 3, the multiplex sublayer shall deliver the data block to
 21 the SCH-mapped logical channel with a Service Reference matching sr_id in the
 22 MuxPDU.

23 The multiplex sublayer shall deliver a Blank data block to each SCH-mapped logical
 24 channel when one or more of the following is true:

- 25 ● The Physical Layer indicates that the Physical Layer frame's size is not 20 ms.
- 26 ● The Physical Layer indicates that the Physical Layer frame's quality is insufficient.
- 27 ● The multiplex sublayer cannot identify the MuxPDU in the Physical Layer SDU, or it
- 28 determines that the MuxPDU is invalid.

29 **2.2.2.2.1.4.4.1.2 LTU Processing**

30 The multiplex sublayer shall use Table 10 to identify the number of LTUs in the
 31 Physical Layer SDU. For each LTU, the multiplex sublayer shall identify the MuxPDUs
 32 in the LTU according to the following:

- 33 ● If the Physical Layer indicates that the Physical Layer frame's quality is insufficient,
- 34 the multiplex sublayer shall check the CRC in the LTU. If the CRC in the LTU is
- 35 incorrect, the multiplex sublayer shall not identify the MuxPDUs in the LTU. If the
- 36 CRC is correct, the multiplex sublayer shall use Table 19 to identify each MuxPDU
- 37 Type 3 in the LTU.
- 38 ● If the Physical Layer indicates that the Physical Layer frame's quality is sufficient,
- 39 the multiplex sublayer shall use Table 19 to identify each MuxPDU Type 3 in the
- 40 LTU.

1 For each valid, non-Fill MuxPDU Type 3, the multiplex sublayer shall deliver the data
 2 block to the SCH-mapped logical channel with a Service Reference matching sr_id in the
 3 MuxPDU.

4 The multiplex sublayer shall deliver a Blank data block to each SCH-mapped logical
 5 channel when one or more of the following is true:

- 6 ● The Physical Layer indicates the Physical Layer frame's quality is insufficient and
 7 there are no LTUs with a correct CRC in the Physical Layer SDU.
- 8 ● The multiplex sublayer cannot identify any MuxPDU in the Physical Layer SDU, or it
 9 determines that all the MuxPDUs are invalid.

10 **2.2.2.2.1.5 MuxPDU Types Processed by the Multiplex Sublayer**

11 Figure 6 shows the MuxPDU types processed by the multiplex sublayer.

12 When the ~~Multiplex Sublayer~~multiplex sublayer is operating in Mode B, and when it is
 13 forming a MuxPDU Type 1, a MuxPDU Type 2 or a MuxPDU Type 3, it shall use the
 14 supplied data blocks to form the MuxPDU according to the following procedures:

- 15 ● The ~~Multiplex Sublayer~~multiplex sublayer shall determine the traffic type of the data
 16 block from the Traffic Channel traffic type in the service option connection record
 17 (i.e., FOR_TRAFFIC for forward traffic type or REV_TRAFFIC for reverse traffic) for
 18 the service option connection associated with the logical channel that supplied the
 19 data block.
- 20 ● The ~~Multiplex Sublayer~~multiplex sublayer shall determine the Service Reference
 21 identifier (sr_id) to be included in MuxPDUs that include an sr_id field according to
 22 the following rules:
 - 23 – If the logical channel that supplied the data block is the dsch, the sr_id field is
 24 set to '000'.
 - 25 – If the logical channel that supplied the data block is a dtch and the MuxPDU is
 26 not a Fill MuxPDU, the sr_id field is set to the sr_id value specified for the
 27 service instance associated with the dtch.
 - 28 – If the MuxPDU is a Fill MuxPDU, the sr_id field is set to '111'.
- 29 ● The ~~Multiplex Sublayer~~multiplex sublayer shall form the MuxPDU as follows:
 - 30 – To form a MuxPDU Type 1, the ~~Multiplex Sublayer~~multiplex sublayer shall
 31 form the MuxPDU according to the set of allowed data block combinations
 32 specified in Table 17.
 - 33 – To form a MuxPDU Type 2, the ~~Multiplex Sublayer~~multiplex sublayer shall
 34 form the MuxPDU according to the set of allowed data block combinations
 35 specified in Table 18.
 - 36 – To form a MuxPDU Type 3, the ~~Multiplex Sublayer~~multiplex sublayer shall
 37 form the MuxPDU according to the set of allowed data block combinations
 38 specified in Table 19.

39

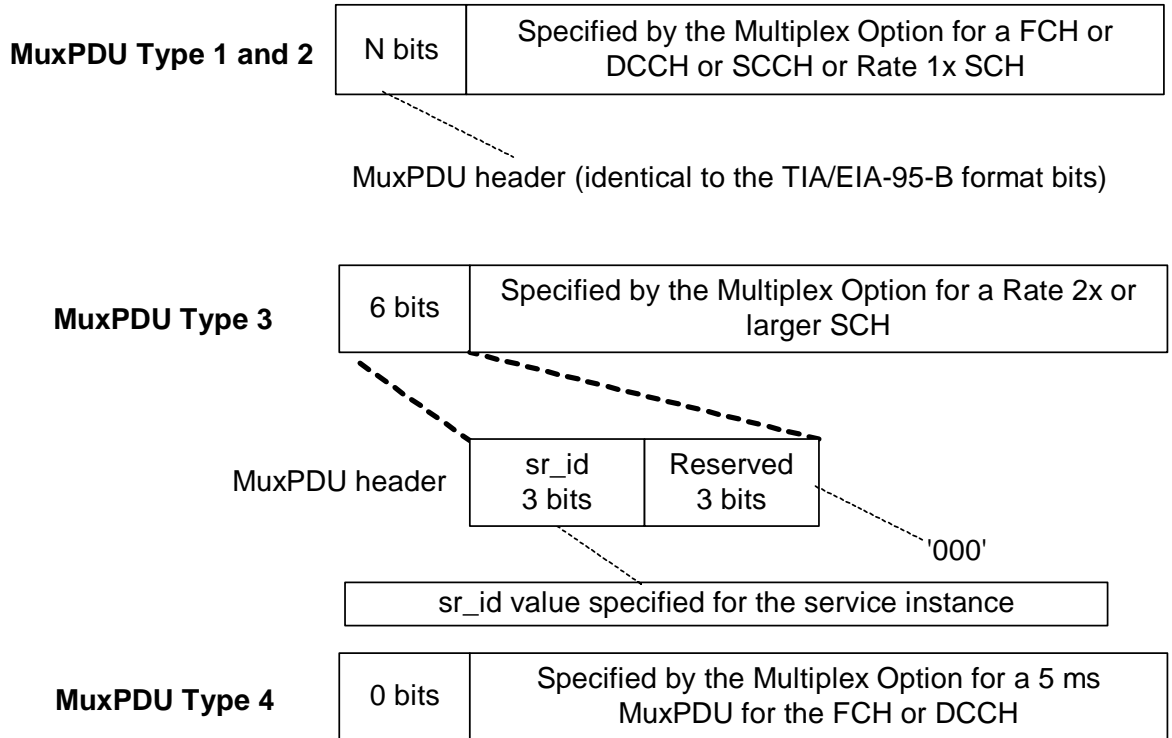

1
2
3
4
5
6
7
8

Figure 6. MuxPDU Types Processed by the Multiplex Sublayer

2.2.2.2.1.5.1 MuxPDU Type 1

Table 17 lists the allowed data block combinations for the FCH, DCCH, SCCH, and SCH. The SCCH referenced in Table 17 is a TIA/EIA-95-B Supplemental Code Channel operating at 9600 bps; the SCH is an ~~IS-2000~~ Supplemental Channel operating at 9600 bps.

1

Table 17. MuxPDU Type 1 Formats

Transmit Rate (bits/sec)	MuxPDU Header			Primary Traffic (bits/block)	Signaling Traffic (bits/block)	Secondary Traffic (bits/block)	Permitted on			
	Mixed Mode (MM)	Traffic Type (TT)	Traffic Mode (TM)				FCH	DCCH	SCCH	SCH
9600	'0'	-	-	171	0	0	Y	Y	Y	Y
	'1'	'0'	'00'	80	88	0	Y	Y	N	N
	'1'	'0'	'01'	40	128	0	Y	Y	N	N
	'1'	'0'	'10'	16	152	0	Y	Y	N	N
	'1'	'0'	'11'	0	168	0	Y	Y	N	N
	'1'	'1'	'00'	80	0	88	Y	Y	N	N
	'1'	'1'	'01'	40	0	128	Y	Y	N	N
	'1'	'1'	'10'	16	0	152	Y	Y	N	N
4800	-	-	-	80	0	0	Y	N	N	N
2400/ 2700	-	-	-	40	0	0	Y	N	N	N
1200/ 1500	-	-	-	16	0	0	Y	N	N	N

2

3 **2.2.2.2.1.5.2 MuxPDU Type 2**

4 Table 18 lists the allowed data block combinations for the FCH, DCCH, SCCH, and
5 SCH. The SCCH referenced in Table 18 is a TIA/EIA-95-B Supplemental Code Channel
6 operating at 14400 bps; the SCH is an IS-2000 Supplemental Channel operating at
7 14400 bps.

1

Table 18. MuxPDU Type 2 Formats

Transmit Rate (bits/sec)	MuxPDU Header					Permitted on			
	Mixed Mode (MM)	Frame Mode (FM)	Primary Traffic (bits/block)	Signaling Traffic (bits/block)	Secondary Traffic (bits/block)	F C H	D C C H	S C C H	S C H
14400	'0'	-	266	0	0	Y	Y	Y	Y
	'1'	'0000'	124	138	0	Y	Y	N	N
	'1'	'0001'	54	208	0	Y	Y	N	N
	'1'	'0010'	20	242	0	Y	Y	N	N
	'1'	'0011'	0	262	0	Y	Y	N	N
	'1'	'0100'	124	0	138	Y	Y	N	N
	'1'	'0101'	54	0	208	Y	Y	N	N
	'1'	'0110'	20	0	242	Y	Y	N	N
	'1'	'0111'	0	0	262	Y	Y	Y	Y
7200	'1'	'1000'	20	222	20	Y	Y	N	N
	'0'	-	124	0	0	Y	N	N	N
	'1'	'000'	54	67	0	Y	N	N	N
	'1'	'001'	20	101	0	Y	N	N	N
	'1'	'010'	0	121	0	Y	N	N	N
	'1'	'011'	54	0	67	Y	N	N	N
	'1'	'100'	20	0	101	Y	N	N	N
	'1'	'101'	0	0	121	Y	N	N	N
3600	'1'	'110'	20	81	20	Y	N	N	N
	'0'	-	54	0	0	Y	N	N	N
	'1'	'00'	20	32	0	Y	N	N	N
	'1'	'01'	0	52	0	Y	N	N	N
	'1'	'10'	20	0	32	Y	N	N	N
1800	'1'	'11'	0	0	52	Y	N	N	N
	'0'	-	20	0	0	Y	N	N	N
	'1'	-	0	0	20	Y	N	N	N

2

3 2.2.2.2.1.5.3 MuxPDU Type 3

4 Table 19 lists the allowed data block combinations for a MuxPDU Type 3. For Rate Set
5 1, a data block containing 170 bits is called a single size data block, and a data block
6 containing 346 bits is called a double size data block. For Rate Set 2, a data block
7 containing 266 bits is called a single size data block, and a data block containing 538
8 bits is called a double size data block.

9 The sr_id field of the MuxPDU shall be set to:

- 10 • the sr_id determined by the data service instance associated with the logical
11 channel that supplied the MuxPDU, if the MuxPDU is not a Fill MuxPDU; or
12 • '111', if the MuxPDU is a Fill MuxPDU.

1 **Table 19. MuxPDU Type 3 Formats**

2

	MuxPDU Header		Traffic bits/ block
	sr_id	Reserved	
Rate Set 1	'001'-'110'	'000'	170/346
	'111'	'000'	0
Rate Set 2	'001'-'110'	'000'	266/538
	'111'	'000'	0

3 **2.2.2.2.1.5.4 MuxPDU Type 4**

4 Table 20 lists the allowed data block combinations for a MuxPDU Type 4. A MuxPDU
5 Type 4 is used to carry a 5 ms data block.

6 **Table 20. MuxPDU Type 4 Formats**

Transmit Rate (bits/sec)	Signaling Traffic (bits/ block)
9600	24

7 **2.2.2.2.1.6 Interface to Signaling LAC**

8 The multiplex sublayer sends a MAC-Availability.Indication (*channel type, max_size,*
9 *system_time*) primitive to the Signaling LAC entity to request information bits from
10 signaling. The multiplex sublayer processes information that is received in a MAC-
11 Data.Request (*channel type, data, size*) primitive from the Signaling LAC entity. The
12 multiplex sublayer sends a MAC-Data.Indication (*channel_id, type, data, size,*
13 *system_time*) primitive to the Signaling LAC entity to indicate that data for the Signaling
14 LAC entity has been received.

15 **2.2.2.2.1.6.1 The MAC-SDUReady.Request Primitive**

16 The multiplex sublayer may process the MAC-SDUReady.Request (*channel type, size,*
17 *scheduling_hint*) primitive. The parameters of this primitive may be used to determine
18 the relative priority between traffic supplied by Signaling and other services. The exact
19 manner for using this information to deliver over-the-air Quality of Service is not
20 specified by this standard. The parameters to this primitive are as follows:

- 21
- *type* is set to “5ms FCH/DCCH frame”, “20ms FCH/DCCH frame”
 - 22 • *size* is set to the number of bits in the Layer 2 encapsulated PDU
 - 23 • *scheduling_hint* is used to indicate to the multiplex sublayer of the MAC how to
24 prioritize fragments of the Layer 2 encapsulated SDU relative to other types of
25 multiplexed traffic.

1 **2.2.2.2.1.6.2 The MAC-Availability.Indication Primitive**

2 | The multiplex sublayer shall send a MAC-Availability.Indication (*channel type*,
3 | *max_size, system_time*) primitive to request information bits from the Signaling LAC
4 | entity whenever the multiplex sublayer is able to carry bits from Layer 2 encapsulated
5 | PDUs. The multiplex sublayer may use information received in a MAC-
6 | SDUReady.Request () primitive (e.g., *scheduling_hint*) to determine when to send MAC-
7 | Availability.Indication () primitive(s) to the Signaling LAC entity., : The parameters of
8 | the MAC-Availability.Indication () primitive shall be set as follows:

- 9 • *type* is the type of signaling message allowed (i.e., 5 ms or 20 ms or either),
- 10 • *max_size* is the maximum number of bits from the Signaling LAC that the multiplex
11 | sublayer can fit into the Physical Layer SDU subject to the current Quality of
12 | Service constraints, (which are not specified by this standard,) (e.g., the multiplex
13 | sublayer may set this parameter to a value that is less than the total available space
14 | in the MuxPDU to permit bits provided by other services to be transported in the
15 | same frame),¹⁴ and
- 16 • *system_time* is the time at which the Physical Layer will transmit the first bit of the
17 | Physical Layer frame containing all of the information bits supplied by signaling.

18 **2.2.2.2.1.6.3 The MAC-Data.Request Primitive**

19 | The multiplex sublayer shall process a MAC-Data.Request (*channel type, data, size*)
20 | primitive from the Signaling LAC entity, where *data* is the Signaling LAC data to be
21 | transmitted. The MAC-Data.Request (*channel type, data, size*) primitive shall be
22 | processed by creating a signaling data block, in accordance with the following
23 | procedure during Physical Layer SDU assembly:

- 24 • If signaling did not supply any information bits (i.e., *data* is NULL), the multiplex
25 | sublayer shall create a Blank data block.
- 26 • If signaling supplied more information bits than the *max_size* parameter indicated
27 | in the corresponding MAC-Availability.Indication (*channel type, max_size, system-*
28 | *time*) primitive, the multiplex sublayer shall discard the information bits and create
29 | a Blank data block.
- 30 • The multiplex sublayer shall fit the received information bits into the closest size
31 | data block allowed by the Rate Set in use by the physical channel¹⁵ which will hold
32 | all of the received bits. If there are not enough information bits to completely fill the
33 | data block, the multiplex sublayer shall fill the unfilled space with '0' bits.

34 **2.2.2.2.1.6.4 The MAC-Data.Indication Primitive**

35 | The multiplex sublayer shall send one MAC-Data.Indication (*channel_id, type, data,*
36 | *size, system_time*) primitive to the Signaling LAC entity for each Physical Layer SDU
37 | containing signaling data. The multiplex sublayer shall not combine information bits
38 | from multiple Physical Layer SDUs.

¹⁴ The maximum number will vary depending upon the type of signaling message, i.e., 5 ms or 20 ms.

¹⁵ The size of the data block will vary depending upon the type of signaling message, i.e., 5 ms or 20 ms.

1 The multiplex sublayer shall include the following parameters in a MAC-Data.Indication
2 (*channel_id*, *type*, *data*, *size*, *system_time*) primitive:

- 3 ● *channel_id* set to a channel identifier for the physical channel on which the data
4 was received (see 2.2.2.2.2.4);
- 5 ● *type* is the Physical Layer frame type (i.e., 5 ms or 20 ms),
- 6 ● *data* is the data for the Signaling LAC entity,
- 7 ● *size* is the size (in bits) of *data*, and
- 8 ● *system_time* is the time at which the Physical Layer received the first bit of the
9 Physical Layer frame containing the information bits.

10 **2.2.2.2.1.7 Interface to the Physical Layer**

11 The ~~Multiplex Sublayer~~**multiplex sublayer** operates in time synchronization with the
12 Physical Layer. If the Physical Layer is transmitting with a non-zero frame offset (see
13 [2]), the ~~Multiplex Sublayer~~**multiplex sublayer** delivers Physical Layer SDUs for
14 transmission by the Physical Layer at the appropriate frame offset from system time.
15 The multiplex sublayer delivers a Physical Layer SDU to the Physical Layer using a
16 physical-channel specific *Transmit Request* service interface operation. The Physical
17 Layer delivers a Physical Layer SDU to the multiplex sublayer using a physical channel
18 specific *Receive Indication* service interface operation.

19 **2.2.2.2.1.7.1 The Transmit FCH Request Service Interface Operation**

20 To deliver a Physical Layer FCH SDU to the Physical Layer, the multiplex sublayer shall
21 send a *Transmit FCH Request* to the Physical Layer with the following arguments:

- 22 ● SDU, which the multiplex sublayer shall set to:
 - 23 – NULL if the Physical Layer FCH SDU contains a Null MuxPDU, or
 - 24 – the Physical Layer FCH SDU if the Physical Layer FCH SDU contains a
25 MuxPDU Type 1 or MuxPDU Type 2 or MuxPDU Type 4.
- 26 ● FRAME_SIZE, which the multiplex sublayer shall set to
 - 27 – 5 ms if the Physical Layer FCH SDU contains a MuxPDU Type 4, or
 - 28 – 20 ms if the Physical Layer FCH SDU contains a MuxPDU Type 1 or
29 MuxPDU Type 2.
- 30 ● FRAME_RATE, which the multiplex sublayer shall set to the MuxPDU's transmit
31 rate if the Physical Layer FCH SDU contains a MuxPDU Type 1 or MuxPDU Type 2
32 or MuxPDU Type 4.

33 **2.2.2.2.1.7.2 The Transmit DCCH Request Service Interface Operation**

34 To deliver a Physical Layer DCCH SDU to the Physical Layer, the multiplex sublayer
35 shall send a *Transmit DCCH Request* to the Physical Layer with the following
36 arguments:

- 37 ● SDU, which the multiplex sublayer shall set to:

- 1 – NULL if the Physical Layer DCCH SDU contains a Null MuxPDU, or
- 2 – the Physical Layer DCCH SDU if the Physical Layer DCCH SDU contains a
- 3 MuxPDU Type 1 or MuxPDU Type 2 or MuxPDU Type 4.
- 4 ● FRAME_DURATION, which the multiplex sublayer shall set to
- 5 – 5 ms if the Physical Layer DCCH SDU contains a MuxPDU Type 4, or
- 6 – 20 ms if the Physical Layer DCCH SDU contains a MuxPDU Type 1 or
- 7 MuxPDU Type 2.
- 8 ● FRAME_RATE, which the multiplex sublayer shall set to the MuxPDU's transmit
- 9 rate if the Physical Layer DCCH SDU contains a MuxPDU Type 1 or MuxPDU Type 2
- 10 or MuxPDU Type 4.

11 **2.2.2.2.1.7.3 The Transmit SCCH Request Service Interface Operation**

12 To deliver a Physical Layer SCCH SDU to the Physical Layer, the multiplex sublayer
13 shall send a *Transmit SCCH Request* to the Physical Layer with the following arguments:

- 14 ● SDU, which the multiplex sublayer shall set to:
 - 15 – NULL if the Physical Layer SCCH SDU contains a Null MuxPDU, or
 - 16 – the Physical Layer SCCH SDU if the Physical Layer SCCH SDU contains a
 - 17 MuxPDU Type 1 or MuxPDU Type 2.
- 18 ● FRAME_DURATION, which the multiplex sublayer shall set to
 - 19 – 20 ms if the Physical Layer SCCH SDU contains a MuxPDU Type 1 or
 - 20 MuxPDU Type 2.
- 21 ● FRAME_RATE, which the multiplex sublayer shall set to the MuxPDU's transmit
- 22 rate if the Physical Layer SCCH SDU contains a MuxPDU Type 1 or MuxPDU Type
- 23 2.

24 **2.2.2.2.1.7.4 The Transmit SCH Request Service Interface Operation**

25 To deliver a Physical Layer SCH SDU to the Physical Layer, the multiplex sublayer shall
26 send a *Transmit SCH Request* to the Physical Layer with the following arguments:

- 27 ● SDU, which the multiplex sublayer shall set to:
 - 28 – NULL if the Physical Layer SCH SDU contains a Null MuxPDU, or
 - 29 – the Physical Layer SCH SDU if the Physical Layer SCH SDU contains a
 - 30 MuxPDU Type 1 or MuxPDU Type 2 or MuxPDU Type 3.
- 31 ● FRAME_DURATION, which the multiplex sublayer shall set to
 - 32 – 20 ms if the Physical Layer SCH SDU contains a MuxPDU Type 1 or
 - 33 MuxPDU Type 2 or MuxPDU Type 3.
- 34 ● FRAME_RATE, which the multiplex sublayer shall set to the SCH's transmit rate.

35 **2.2.2.2.1.7.5 The Receive FCH Indication Service Interface Operation**

36 The Physical Layer delivers an FCH SDU to the multiplex sublayer using a *Receive FCH*
37 *Indication* with the following arguments:

- 38 ● SDU, which the Physical Layer sets to the Physical Layer FCH SDU if the Physical
- 39 Layer received a Physical Layer FCH frame.

- 1 ● FRAME_DURATION, which the Physical Layer sets to the duration of the received
- 2 Physical Layer frame (i.e., 5 ms or 20 ms).
- 3 ● FRAME_RATE, which the Physical Layer sets to the data rate of the received
- 4 Physical Layer frame.
- 5 ● FRAME_QUALITY, which the Physical Layer sets to the frame quality of the received
- 6 Physical Layer frame (i.e., sufficient or insufficient).

7 **2.2.2.2.1.7.6 The Receive DCCH Indication Service Interface Operation**

8 The Physical Layer delivers an DCCH SDU to the multiplex sublayer using a *Receive*
9 *DCCH Indication* with the following arguments:

- 10 ● SDU, which the Physical Layer sets to:
 - 11 – NULL if the Physical Layer did not receive a Physical Layer DCCH frame, or
 - 12 – the Physical Layer DCCH SDU if the Physical Layer received a Physical Layer
 - 13 DCCH frame.
- 14 ● FRAME_DURATION, which the Physical Layer sets to the duration of the received
- 15 Physical Layer frame (i.e., 5 ms or 20 ms).
- 16 ● FRAME_RATE, which the Physical Layer sets to the data rate of the received
- 17 Physical Layer frame.
- 18 ● FRAME_QUALITY, which the Physical Layer sets to the frame quality of the received
- 19 Physical Layer frame (i.e., sufficient or insufficient).

20 **2.2.2.2.1.7.7 The Receive SCCH Indication Service Interface Operation**

21 The Physical Layer delivers an SCCH SDU to the multiplex sublayer using a *Receive*
22 *SCCH Indication* with the following arguments:

- 23 ● SDU, which the Physical Layer sets to the Physical Layer SCCH SDU if the Physical
- 24 Layer received a Physical Layer SCCH frame.
- 25 ● FRAME_DURATION, which the Physical Layer sets to the duration of the received
- 26 Physical Layer frame (i.e., 20 ms).
- 27 ● FRAME_RATE, which the Physical Layer sets to the data rate of the received
- 28 Physical Layer frame.
- 29 ● FRAME_QUALITY, which the Physical Layer sets to the frame quality of the received
- 30 Physical Layer frame (i.e., sufficient or insufficient).

31 **2.2.2.2.1.7.8 The Receive SCH Indication Service Interface Operation**

32 The Physical Layer delivers an SCH SDU to the multiplex sublayer using a *Receive SCH*
33 *Indication* with the following arguments:

- 34 ● SDU, which the Physical Layer sets to the Physical Layer SCH SDU if the Physical
- 35 Layer received a Physical Layer SCH frame.
- 36 ● FRAME_DURATION, which the Physical Layer sets to the duration of the received
- 37 Physical Layer frame (i.e., 20 ms).
- 38 ● FRAME_RATE, which the Physical Layer sets to the data rate of the received
- 39 Physical Layer frame.

- 1 ● FRAME_QUALITY, which the Physical Layer sets to the frame quality of the received
- 2 Physical Layer frame (i.e., sufficient or insufficient).

- 1 **2.2.2.2.2 SRBP and Common Channel Multiplex Sublayer**
- 2 **2.2.2.2.2.1 Overview (Informative)**

1 **2.2.2.2.1.1 Sync Channel Procedures**

2 The Sync Channel is used to provide time and frame synchronization to the mobile
 3 station.

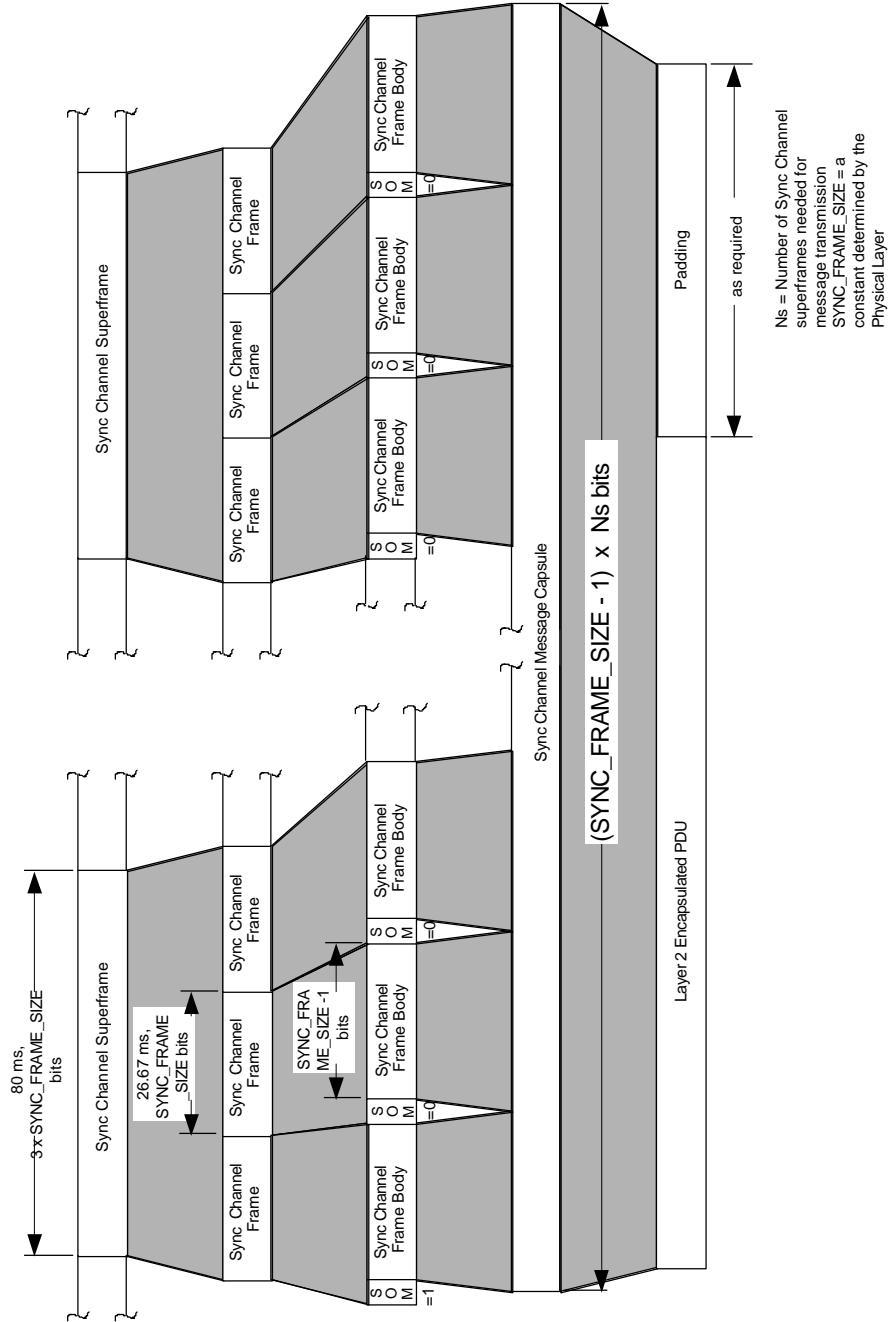

4

5

Figure 7. Sync Channel Structure (1200bps) Example

6 **2.2.2.2.1.2 Paging Channel Procedures**

7 The Paging Channel is used to send control information to mobile stations that have not
 8 been assigned to a Traffic Channel.

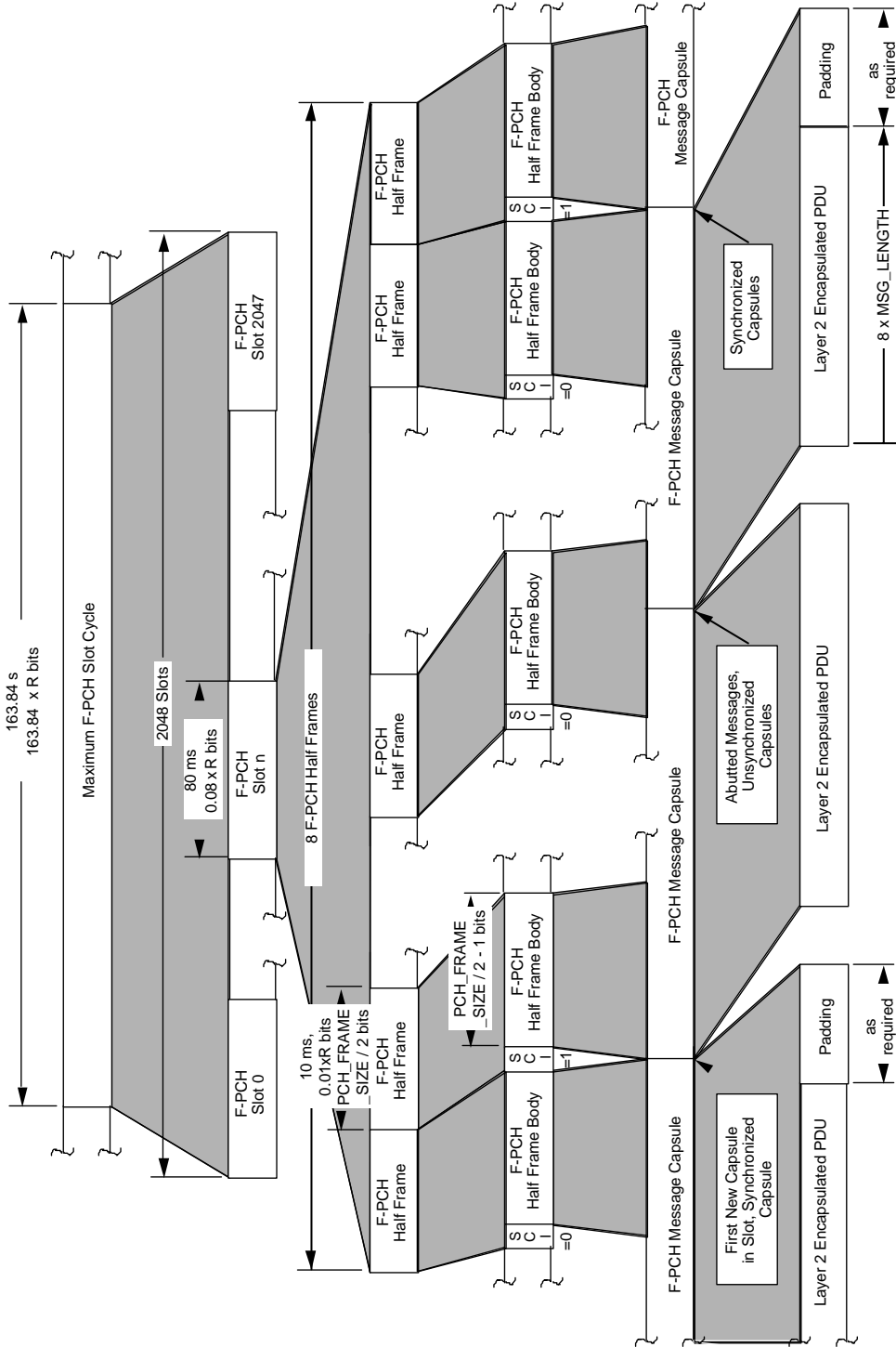

Note 1: See IS-2000-5 for maximum length limitations. R = F-PCH data rate (9600 bps or 4800 bps)

1
2
3

Figure 8. Paging Channel Structure Example

1 2.2.2.2.1.3 Access Procedures

2 The entire process of sending one Layer 2 encapsulated PDU and receiving (or failing to
3 receive) an acknowledgment for the PDU is called an access attempt (see Figure 9). One
4 access attempt consists of one or more access sub-attempts (see Figure 9 and Figure
5 10). Each transmission in the access sub-attempt is called an access probe. Each
6 access probe consists of an R-ACH preamble and a R-ACH message capsule (see Figure
7 10).

8 Within an access sub-attempt, access probes are grouped into access probe sequences.
9 The R-ACH used for each access probe sequence is chosen pseudorandomly from
10 among all the R-ACHs associated with the current F-PCH. If there is only one R-ACH
11 associated with the current F-PCH, all access probes within an access probe sequence
12 are transmitted on the same R-ACH. If there is more than one R-ACH associated with
13 the current F-PCH, all access probes within an access probe sequence may be
14 transmitted on the different R-ACHs associated with the current F-PCH. Each access
15 probe sequence consists of up to $1 + \text{NUM_STEP}_s$ access probes. The first access probe
16 of each access probe sequence is transmitted at an initial power level determined by the
17 Physical Layer relative to the nominal open loop power level. Each subsequent access
18 probe within an access probe sequence is transmitted at a power level that is a function
19 of PWR_LVL , calculated by the SRBP entity.

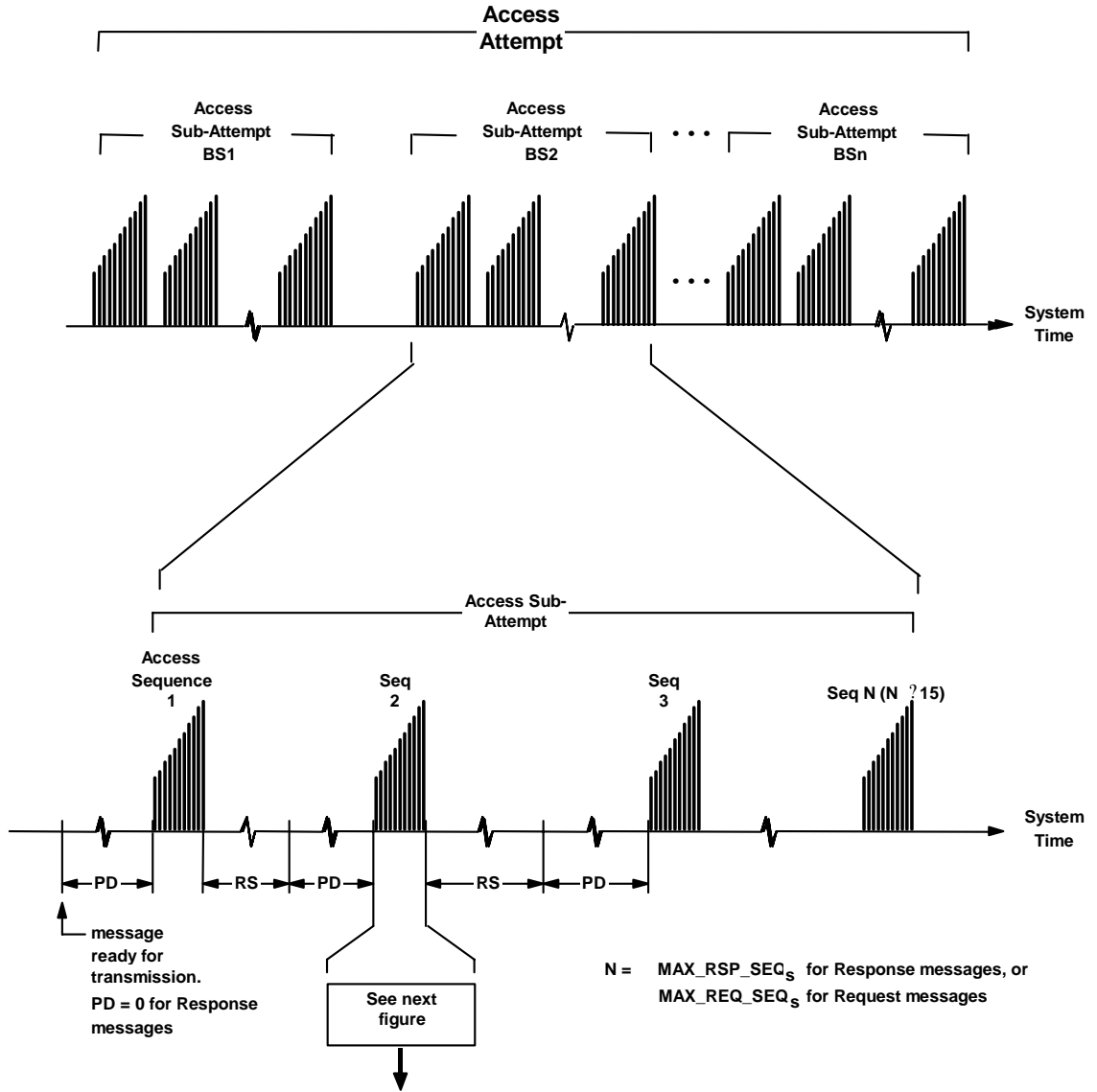

1
2
3
4

Figure 9. Access Attempt (Part 1)¹⁶

¹⁶ This figure contains some detailed information of the Access Attempt that is outside the scope of this document

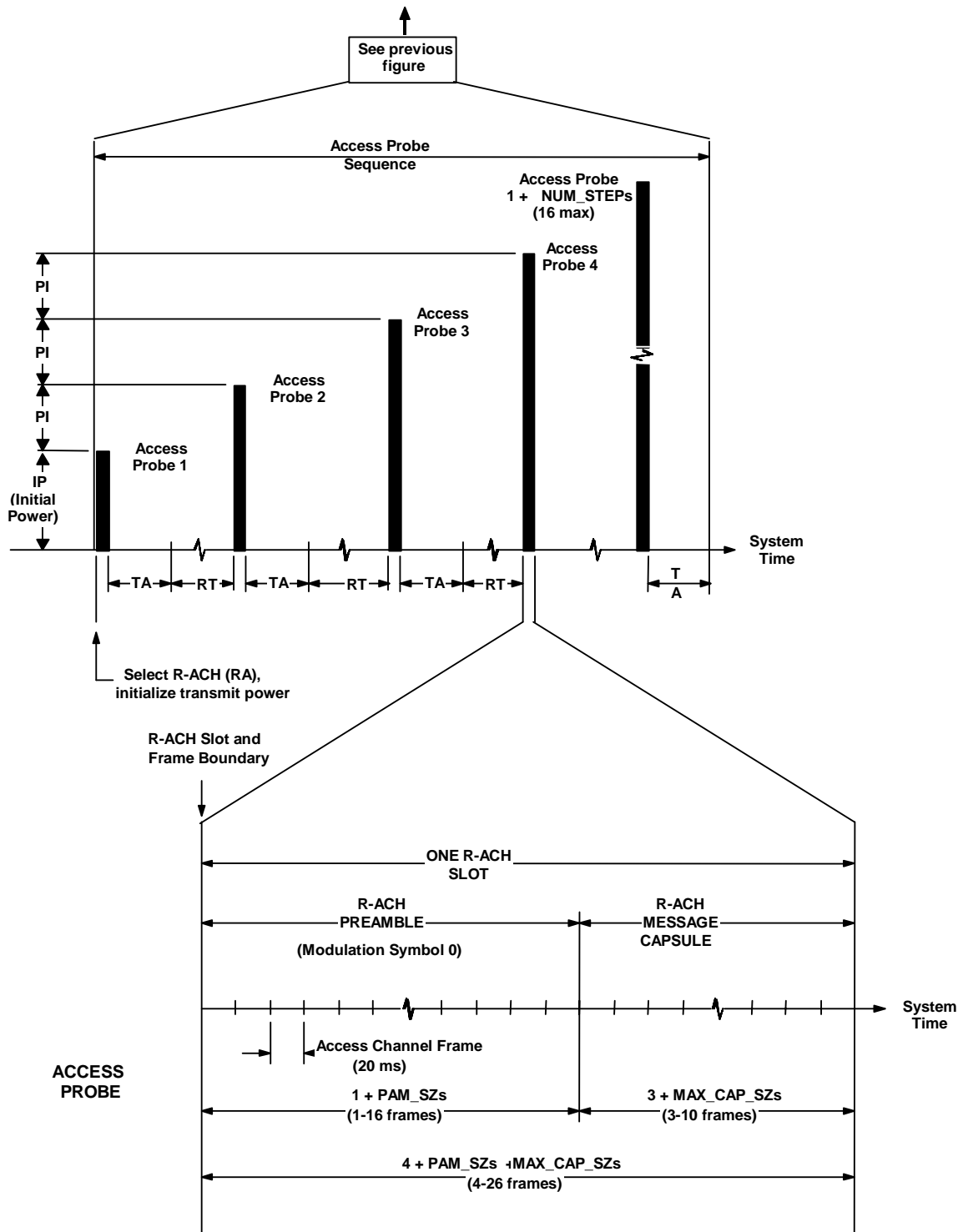

1
2
3

Figure 10. Access Attempt (Part 2)

1 The timing of access probes and access probe sequences is expressed in terms of R-
 2 ACH slots (see Figure 11). The transmission of an access probe begins at the start of an
 3 R-ACH slot. The timing of the start of each access probe sequence is determined
 4 pseudorandomly. For every access probe sequence, a backoff delay, RS , from 0 to $1 +$
 5 $BKOFF_S$ slots is generated pseudorandomly. An additional delay is imposed by the use
 6 of a random persistence test that determines the value of the Persistence Delay, PD^{17} ,
 7 based on the parameter P of the MAC-SDUReady.Request primitive.

8 For each slot after the backoff delay, RS , the SRBP entity performs a pseudorandom
 9 test based on the parameter P of the MAC-SDUReady.Request primitive. If the test
 10 passes, the first access probe of the sequence begins in that slot. If the test fails, the
 11 access probe sequence is deferred until at least the next slot.

12 The delay between access probes of an access probe sequence is generated
 13 pseudorandomly. Upon reception of an acknowledgement from the base station, the
 14 upper layer terminates the access by no longer sending the MAC-SDUReady.Request
 15 primitive. If a MAC-SDUReady.Request primitive with $(seqno \bmod (\text{NUM_STEP}_S + 1))$ not
 16 equal to 0 is received:

- 17 • If the ~~Common Channel Multiplex Sublayer~~common channel multiplex sublayer
 18 transmits all the access probes within an access probe sequence on the same R-
 19 ACH associated with the current F-PCH, the next access probe is transmitted after
 20 an additional backoff delay, RT , from 0 to $1 + \text{PROBE_BKOFF}_S$ slots.
- 21 • If the ~~Common Channel Multiplex Sublayer~~common channel multiplex sublayer
 22 pseudorandomly selects an R-ACH from among all R-ACHs associated with the
 23 current F-PCH, the next access probe is transmitted after an additional backoff
 24 delay, RT , from 0 to PROBE_BKOFF_S slots.

25 The precise timing of the Access Channel transmissions in an access attempt is
 26 determined by a procedure called PN randomization. For each access sub-attempt, the
 27 SRBP entity computes a delay, RN , from 0 to $2^{\text{PROBE_PN_RAN}_S} - 1$ PN chips using a
 28 hash function, which is a function of $RN_HASH_KEY_S$ and PROBE_PN_RAN_S (see
 29 2.2.2.2.2.3.4). The variables that are related to the random access are shown in Table
 30 21.

¹⁷A persistence test is not needed for sending SDUs that contain response messages, because the base station controls the arrival rate of response messages directly by controlling the rate at which it transmits messages requiring responses.

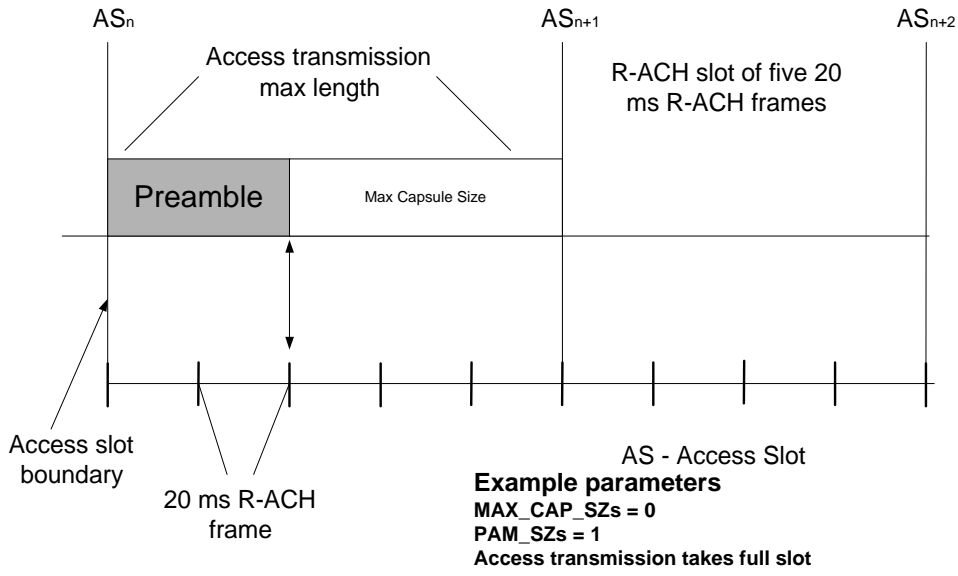

1

2

Figure 11. Example of R-ACH Slot Structure

1

Table 21. Calculated, Random, and Hashed Variables

Variable	Name	Generation	Range	Units
PD	Persistence Delay	Delay continues slot-by-slot until persistence test (run every slot) passes.	—	slots
RA	R-ACH Number	Random between 0 and ACC_CHAN _S ; generated before every access probe sequence or every access probe.	0 to 31	—
RN	PN Randomization Delay	Hash using RN_HASH_KEY _S between 0 and 2 ^{PROBE_PN_RAN_S} - 1; generated once at the beginning of each access sub-attempt.	0 to 511	chips
RS	Sequence Backoff	Random between 0 and 1 + BKOFF _S ; generated before every sequence of an access sub-attempt (except the first sequence).	0 to 16	slots
RT	Probe Backoff	Random between 0 and 1 + PROBE_BKOFF _S ; generated before subsequent probes if the mobile station transmits all access probes within an access probe sequence on the same R-ACH. Random between 0 and PROBE_BKOFF _S ; generated before subsequent probes if the Common Channel Multiplex Sublayer common channel multiplex sublayer pseudorandomly selects an R-ACH from among all R-ACHs associated with the current Paging Channel.	0 to 16	slots

2

3 2.2.2.2.1.4 R-ACH Structure

4 The base station shall set the ACH_FRAME_SIZE to 88.

5 An R-ACH slot is (3 + MAX_CAP_SZ_S) + (1 + PAM_SZ_S) R-ACH frames in length. An R-
6 ACH slot begins and ends on R-ACH frame boundary. R-ACH slots begin at R-ACH
7 frames, in which

$$8 \quad t \bmod (4 + \text{MAX_CAP_SZ}_S + \text{PAM_SZ}_S) = 0,$$

9

10 where t is the System Time in frames. Note that all R-ACHs associated with a
11 particular F-PCH have the same slot size, and that all of the slots begin at the same
12 time. Figure 11 shows an example of R-ACH slots and Figure 12 shows the R-ACH
13 structure.

14 An R-ACH transmission consists of the R-ACH preamble and the Layer 2 encapsulated
15 PDU. An R-ACH transmission is an integer number of R-ACH frames in length, and
16 does not exceed 4 + MAX_CAP_SZ_S + PAM_SZ_S R-ACH frames in length.

1 On each R-ACH transmission, the mobile station transmits a preamble consisting of
2 frames of (ACH_FRAME_SIZE + Length of Tail bits) zeros, starting at the beginning of
3 the slot (plus PN randomization, as specified in the "Pseudorandom Number Generator"
4 section of ~~IS-2000-5~~5) and 1 + PAM_SZ_s R-ACH frames in length.. The mobile station
5 transmits the R-ACH Message capsule, immediately following the preamble (see Figure
6 12).

7

1

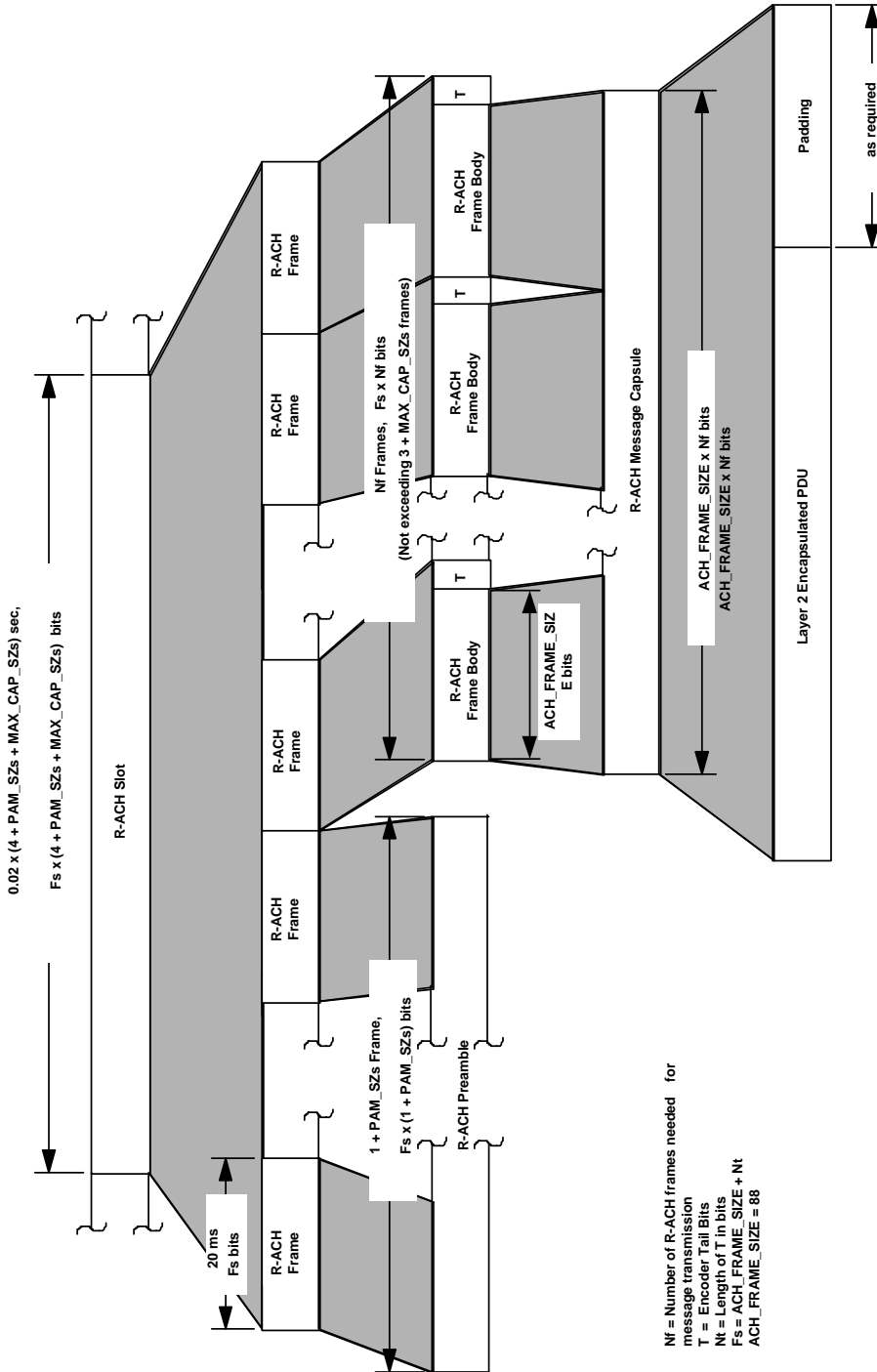

2

3

Figure 12. R-ACH Structure¹⁸

¹⁸ This figure contains some detailed information of the Access Channel structure that is outside the scope of this document

1

2 **2.2.2.2.1.5 R-ACH Message Capsule Structure**

3 An R-ACH message capsule consists of a Layer 2 encapsulated PDU and the padding
 4 added by the ~~Common Channel Multiplex Sublayer~~common channel multiplex sublayer,
 5 as shown in Figure 13. The length of the R-ACH message capsule is an integer number
 6 of R-ACH frames given by

$$7 \quad \text{CAP_SZ} = \lceil \text{size} / \text{ACH_FRAME_SIZE} \rceil,$$

8 where *size* is passed by the MAC-SDUReady.Request primitive.

9 The mobile station transmits the Layer 2 encapsulated PDU, immediately following the
 10 preamble. The mobile station transmits padding, consisting of zero or more '0' bits
 11 immediately following the Layer 2 encapsulated PDU. The length of the padding is
 12 equal to $\text{CAP_SZ} \times \text{ACH_FRAME_SIZE} - \text{size}$.

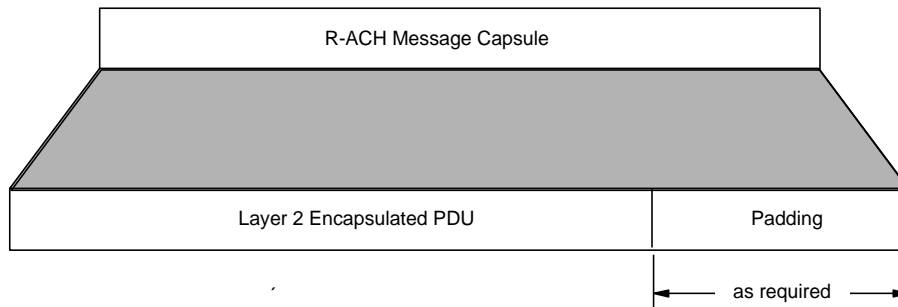

13

14

Figure 13. R-ACH Message Capsule Structure

1 **2.2.2.2.2 Mobile Station Procedures**

2 **2.2.2.2.2.1 Sync Channel Procedures**

3 If the ~~Common Channel Multiplex Sublayer~~common channel multiplex sublayer |
 4 receives a *Receive F-SYNC Indication* from the Physical Layer with SDU as the
 5 argument, the SRBP entity shall send a MAC-Data.Indication (*channel_id*, *type*, *data*,
 6 *size*, *system_time*) primitive with:

- 7 ● *type* set to “F-SYNC frame”,
- 8 ● *data* set to SDU,
- 9 ● *size* set to the size of *data* in bits; and
- 10 ● *system_time* set to the time associated with the Physical Layer frame which carried
 11 the F-SYNC SDU.

12 **2.2.2.2.2.2 Paging Channel Procedures**

13 If the ~~Common Channel Multiplex Sublayer~~common channel multiplex sublayer |
 14 receives a *Receive F-PCH Indication* from the Physical Layer with SDU as the argument,
 15 the ~~SRBP~~common channel multiplex sublayer entity shall send a MAC-Data.Indication |
 16 (*channel_id*, *type*, *data*, *size*, *system_time*) primitive with:

- 17 ● *type* set to “F-PCH frame”,
- 18 ● *data* set to SDU;
- 19 ● *size* set to the size of *data* in bits; and
- 20 ● *system_time* set to the time associated with the Physical Layer frame which carried
 21 the F-PCH SDU.

1 **2.2.2.2.2.3 Access Procedures**

2 This section specifies the random access procedures at the mobile station for sending
3 Layer 2 encapsulated PDUs on the R-ACH (see Figure 14).

4 **2.2.2.2.2.3.1 Processing of the MAC-SDUReady.Request Primitive**

5 Upon reception of a MAC-SDUReady.Request (*channel* type, size, *P*, *seqno*) primitive,
6 the SRBP entity shall do the following:

- 7 • If *seqno* is equal to 0:
- 8 – The SRBP entity shall compute a number, RN, from 0 to $2^{\text{PROBE_PN_RAN}_S} - 1$,
9 using the hashing technique described in 2.2.2.2.2.3.4.
 - 10 – The SRBP entity shall perform a persistence test for each R-ACH slot until
11 the test passes. To perform the persistence test, the SRBP entity shall
12 generate a random number RP, $0 < RP < 1$, using the technique described in
13 the "Pseudorandom Number Generator" section of ~~IS-2000-5~~[5]. The
14 persistence test is said to pass when RP is less than the value of *P*.
 - 15 – The ~~Common Channel Multiplex Sublayer~~common channel multiplex
16 sublayer shall generate a random number, RA, from 0 to ACC_CHAN_S using
17 the procedure described in the "Pseudorandom Number Generator" section
18 of ~~IS-2000-5~~[5].
- 19 • If *seqno* is non-zero and (*seqno* mod ($\text{NUM_STEP}_S + 1$)) is equal to 0:
- 20 – The SRBP entity shall generate a random number, RS, from 0 to ($\text{BKOFF}_S +$
21 1), using the procedure described in the "Pseudorandom Number Generator"
22 section of ~~IS-2000-5~~[5].
 - 23 – The SRBP entity shall wait for RS R-ACH slots and then perform a
24 persistence test for each R-ACH slot until the test passes (see above).
 - 25 – The ~~Common Channel Multiplex Sublayer~~common channel multiplex
26 sublayer shall generate a random number, RA, from 0 to ACC_CHAN_S using
27 the procedure described in the "Pseudorandom Number Generator" section
28 of ~~IS-2000-5~~[5].
- 29 • If (*seqno* mod ($\text{NUM_STEP}_S + 1$)) is non-zero:

- 1 – If the ~~Common Channel Multiplex Sublayer~~common channel multiplex
2 sublayer transmits all access probes within an access probe sequence on the
3 same R-ACH, the SRBP entity shall generate a random number, RT, from 0
4 to $1 + \text{PROBE_BKOFF}_S$, using the procedure described in the
5 "Pseudorandom Number Generator" section of ~~IS-2000-5~~[5].
6 – If the ~~Common Channel Multiplex Sublayer~~common channel multiplex
7 sublayer pseudorandomly selects an R-ACH among all the R-ACHs
8 associated with the current F-PCH, the SRBP entity shall generate a random
9 number, RT, from 0 to PROBE_BKOFF_S , using the procedure described in
10 the "Pseudorandom Number Generator" section of ~~IS-2000-5~~[5]. If there is
11 more than one R-ACH associated with the current Paging Channel, the
12 ~~Common Channel Multiplex Sublayer~~common channel multiplex sublayer
13 should generate a random number, RA, from 0 to ACC_CHAN_S using the
14 procedure described in the "Pseudorandom Number Generator" section of ~~IS-~~
15 ~~2000-5~~[5].
16 – The SRBP entity shall wait for RT R-ACH slots.
17 • Perform the procedures described in 2.2.2.2.2.3.2.

18 **2.2.2.2.2.3.2 Transmitting an Access Probe**

19 When transmitting an access probe, the SRBP entity shall do the following:

- 20 • Set PWR_LVL to (*seqno* mod ($\text{NUM_STEP}_S + 1$)).
21 • The ~~Common Channel Multiplex Sublayer~~common channel multiplex sublayer shall
22 send a *Transmit R-ACH Preamble Request* to the Physical Layer with the following
23 arguments:
24 – RA,
25 – PWR_LVL,
26 – RN, and
27 – NUM_PREAMBLE_FRAMES set to $(1 + \text{PAM_SZ}_S)$.
28 • After the transmission of the preamble, the SRBP entity shall send a MAC-
29 Availability.Indication primitive and wait for the reception of the matching MAC-
30 Data.Request primitive, for each R-ACH frame, until all the fragments of the Layer 2
31 encapsulated PDU are transmitted. When sending the MAC-Availability.Indication
32 primitive, the SRBP entity shall set *max_size* to ACH_FRAME_SIZE , and
33 *system_time* to the time at which the frame will be transmitted (see 2.2.2.2.2.3.3
34 for the processing of the MAC-Data.Request primitive).

35 **2.2.2.2.2.3.3 Processing of the MAC-Data.Request Primitive**

36 Upon reception of the MAC-Data.Request (*channel type*, *data*, *size*) primitive with non-
37 zero *size*, the SRBP entity shall perform the following:

- 38 • The SRBP entity shall add $(\text{ACH_FRAME_SIZE} - \textit{size})$ '0' bits to *data* to form a
39 Physical Layer R-ACH SDU.
40 • The ~~Common Channel Multiplex Sublayer~~common channel multiplex sublayer shall
41 send a *Transmit R-ACH Frame Request to the Physical Layer* with the following
42 arguments:

- 1 – RA,
- 2 – PWR_LVL,
- 3 – RN, and
- 4 – SDU set to the assembled R-ACH SDU.

5 **2.2.2.2.2.3.4 Hash Function**

6 The following function returns the value of RN, using RN_HASH_KEY_S and
 7 PROBE_PN_RAN_S as arguments as described below. Note that DECORR is a modifier
 8 that serves to decorrelate the values obtained for the various applications from the
 9 same mobile station.

10 Define:

- 11 • Word L to be bits 0-15 of RN_HASH_KEY_S, where bit 0 is the least significant bit of
 12 RN_HASH_KEY_S,
- 13 • Word H to be bits 16-31 of RN_HASH_KEY_S, where bit 0 is the least significant bit of
 14 RN_HASH_KEY_S,
- 15 • N to be $2^{\text{PROBE_PN_RAN}_S}$, and
- 16 • DECORR to be RN_HASH_KEY_S [0...11], where RN_HASH_KEY_S [0...11] denotes the
 17 12 least significant bits of RN_HASH_KEY_S.

18 Then RN is computed as follows:¹⁹

$$19 \quad \text{RN} = \lfloor N \times ((40503 \times (L \oplus H \oplus \text{DECORR})) \bmod 2^{16}) / 2^{16} \rfloor,$$

20 where \oplus denotes bitwise modulo-2 addition.

¹⁹This formula is adapted from Knuth, Donald N., *The Art of Computer Programming*, 2 volumes, (Reading, MA, Addison-Wesley, 1998).

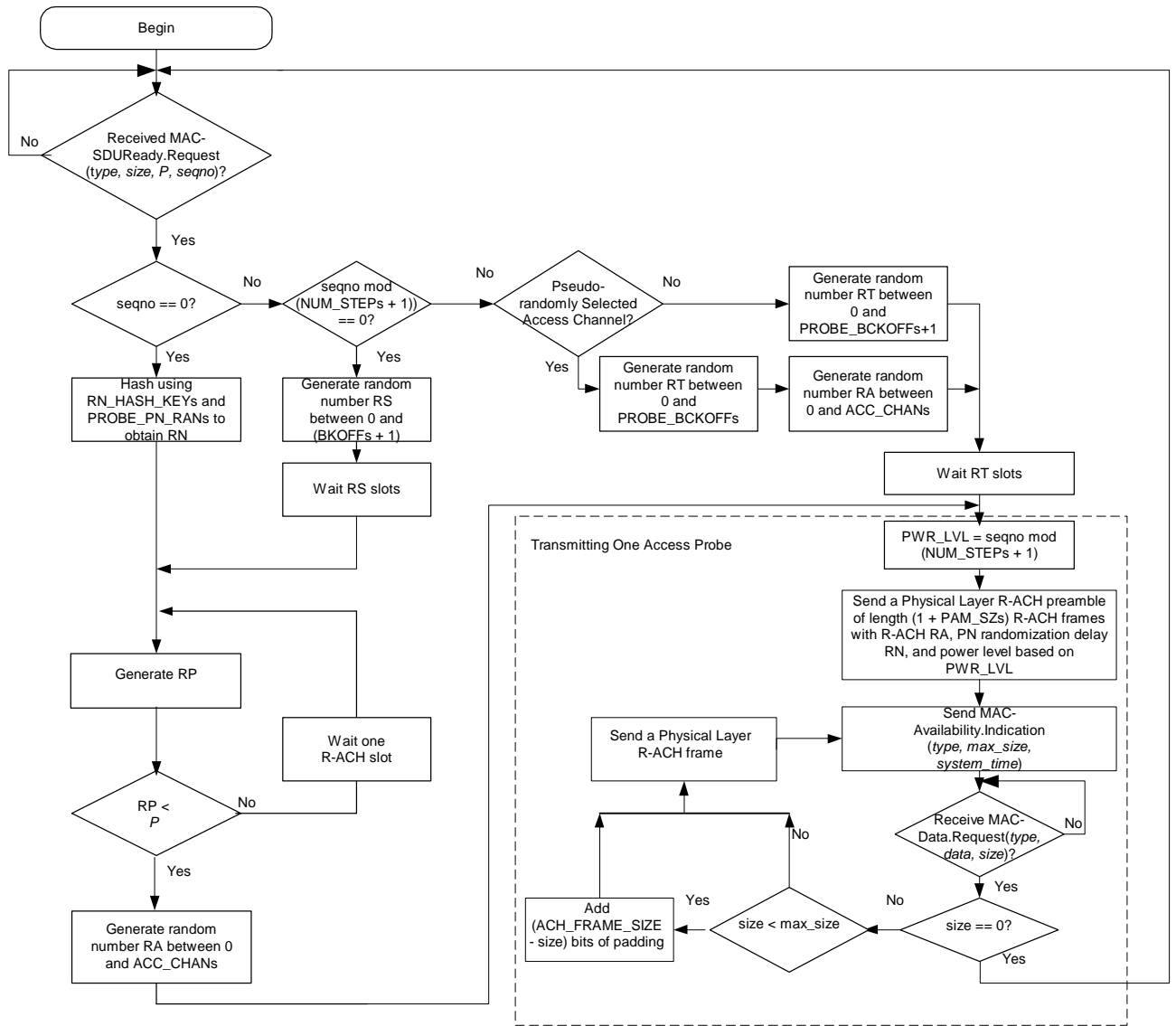

1
2
3

Figure 14. Example of Random Access Procedures at the Mobile Station

1 **2.2.2.2.2.3 Base Station Procedures**

2 **2.2.2.2.2.3.1 Sync Channel Procedures**

3 The base station shall set the SYNC_FRAME_SIZE to 32.

4 When the base station is transmitting the F-SYNC, the SRBP entity shall generate a
5 | MAC-Availability.Indication (*channel_type*, *max-size*, *system_time*) primitive every (80 ÷
6 | 3) ms, with:

- 7 • *type* set to “F-SYNC frame”,
- 8 • *max-size* set to SYNC_FRAME_SIZE, and
- 9 • *system_time* set to the time associated with the F-SYNC frame which will carry the
10 F-SYNC SDU.

11 | Upon reception of a MAC-Data.Request (*channel_type*, *data*, *size*) primitive, the SRBP
12 | entity shall perform the following:

- 13 • The SRBP entity shall append (SYNC_FRAME_SIZE - *size*) '0' bits to *data* to form a
14 Physical Layer F-SYNC SDU.
- 15 | • The ~~Common Channel Multiplex Sublayer~~ **common channel multiplex sublayer** shall
16 | send a *Transmit F-SYNC Request* to the Physical Layer with the argument SDU set to
17 | the assembled F-SYNC SDU.

18 **2.2.2.2.2.3.2 Paging Channel Procedures**

19 The base station shall set PCH_FRAME_SIZE to 96 if the F-PCH data rate is 4800 bps,
20 or to 192 if the F-PCH data rate is 9600 bps.

21 When the base station is transmitting an F-PCH, the SRBP entity shall generate a
22 | MAC-Availability.Indication (*channel_type*, *max_size*, *system_time*) primitive every 20
23 | ms, with:

- 24 • *type* set to “F-PCH frame”,
- 25 • *max-size* set to PCH_FRAME_SIZE, and
- 26 • *system_time* set to the time associated with the F-PCH frame which will carry the F-
27 PCH SDU.

28 | Upon reception of a MAC-Data.Request (*channel_type*, *data*, *size*) primitive, the SRBP
29 | entity shall perform the following:

- 30 • The SRBP entity shall append (PCH_FRAME_SIZE-*size*) '0' bits to *data* to form a
31 Physical Layer F-PCH SDU.
- 32 | • The ~~Common Channel Multiplex Sublayer~~ **common channel multiplex sublayer** shall
33 | send a *Transmit F-PCH Request* to the Physical Layer with the argument SDU set to
34 | the assembled F-PCH SDU.

35 **2.2.2.2.2.3.3 Access Channel Procedures**

36 | If the ~~Common Channel Multiplex Sublayer~~ **common channel multiplex sublayer**
37 | receives a *Receive R-ACH Indication* from the Physical Layer with SDU as an argument,
38 | the **common channel multiplex sublayer** ~~SRBP~~ entity shall send a MAC-Data.Indication
39 | (*channel_id*, *type*, *data*, *size*, *system_time*) primitive with:

- 1 ● *data* set to SDU;
- 2 ● *size* set to the size of *data* in bits; and
- 3 ● *system_time* set to the time associated with the R-ACH frame which carries the
- 4 SDU.

5 **2.2.2.2.4 Procedures for Generating the Channel Identifier**

6 ~~The SRBP entity on the BS shall set *channel_id* to Null.~~ The SRBP entity ~~on the MS~~ shall generate a channel identifier, *channel_id*, for the physical channel on which the
 7 data was received to be included in MAC-Data.Indication primitives. The *channel_id*
 8 values included in any two MAC-Data.Indication primitives shall be the same if all of
 9 the following are true:

- 11 ● the received data were transmitted by the same base station,
 - 12 ● the received data were transmitted on the same code channel, and
 - 13 ● the received data were transmitted on the same CDMA Channel.
- 14 Otherwise, the *channel_id* values included in the MAC-Data.Indication primitives shall
 15 have distinct values.

16 **2.2.3 Supervisory Procedures**

17 **2.2.3.1 Mobile Station Transmission Statistics**

18 The mobile station shall count, by physical channel, the number and type of Physical
 19 Layer SDU that the multiplex sublayer delivers to the Physical Layer. Each counter
 20 used for this purpose shall be 24 bits long. The mobile station shall initialize each
 21 counter that it maintains to zero upon power-on. The mobile station shall not
 22 reinitialize any counter except upon command from the base station. Each counter
 23 shall be maintained modulo 2^{24} .

24 Each time the multiplex sublayer delivers a Physical Layer SDU to the Physical Layer, it
 25 shall increment the counter corresponding to the physical channel and the type of
 26 Physical Layer SDU. If the mobile station also supports LTU processing, it shall also
 27 increment the counter corresponding to the physical channel for each LTU in the
 28 Physical Layer SDU.

29 **2.2.3.1.1 Mobile Station Transmission Statistics for the FCH**

30 The mobile station shall maintain counters 1 through 8 in Table 22. If the mobile
 31 station also supports secondary traffic on the FCH, it shall also maintain counters 11
 32 through 14 in Table 22. If the mobile station supports MuxPDU Type 4 on the FCH, it
 33 shall also maintain counter 16 in Table 22.

1

Table 22. FCH Transmission Counters for Multiplex Option 0x1

Counter Number	Counter Name	Description
1	MUX1_REV_FCH_1	9600 bps, MuxPDU Type 1 Header = '0' or null traffic MuxPDU
2	MUX1_REV_FCH_2	9600 bps, MuxPDU Type 1 Header = '1000'
3	MUX1_REV_FCH_3	9600 bps, MuxPDU Type 1 Header = '1001'
4	MUX1_REV_FCH_4	9600 bps, MuxPDU Type 1 Header = '1010'
5	MUX1_REV_FCH_5	9600 bps, MuxPDU Type 1 Header = '1011'
6	MUX1_REV_FCH_6	4800 bps, MuxPDU Type 1 or null traffic MuxPDU
7	MUX1_REV_FCH_7	2400, bps MuxPDU Type 1 or null traffic MuxPDU
8	MUX1_REV_FCH_8	1200, bps MuxPDU Type 1 or null traffic MuxPDU
9	MUX1_REV_FCH_9	reserved
10	MUX1_REV_FCH_10	reserved
11	MUX1_REV_FCH_11	9600 bps, MuxPDU Type 1 Header = '1100'
12	MUX1_REV_FCH_12	9600 bps, MuxPDU Type 1 Header = '1101'
13	MUX1_REV_FCH_13	9600 bps, MuxPDU Type 1 Header = '1110'
14	MUX1_REV_FCH_14	9600 bps, MuxPDU Type 1 Header = '1111'
15	MUX1_REV_FCH_15	reserved
16	MUX1_REV_FCH_5_ms	MuxPDU Type 4

2

3 If the mobile station supports multiplex option 0x2 on the FCH, it shall maintain
4 counters 1 through 5, 11 through 14, 19 through 21, and 24 in Table 23. If the mobile
5 station also supports secondary traffic on the FCH, it shall also maintain counters 6
6 through 10, 15 through 18, 22 through 23, and 25 in Table 23. If the mobile station
7 supports MuxPDU Type 4 on the FCH, it shall also maintain counter 28 in Table 23.

1

Table 23. FCH Transmission Counters for Multiplex Option 0x2

Counter Number	Counter Name	Description
1	MUX2_REV_FCH_1	14400 bps, MuxPDU Type 2 Header = '0' or null traffic MuxPDU
2	MUX2_REV_FCH_2	14400 bps, MuxPDU Type 2 Header = '10000'
3	MUX2_REV_FCH_3	14400 bps, MuxPDU Type 2 Header = '10001'
4	MUX2_REV_FCH_4	14400 bps, MuxPDU Type 2 Header = '10010'
5	MUX2_REV_FCH_5	14400 bps, MuxPDU Type 2 Header = '10011'
6	MUX2_REV_FCH_6	14400 bps, MuxPDU Type 2 Header = '10100'
7	MUX2_REV_FCH_7	14400 bps, MuxPDU Type 2 Header = '10101'
8	MUX2_REV_FCH_8	14400 bps, MuxPDU Type 2 Header = '10110'
9	MUX2_REV_FCH_9	14400 bps, MuxPDU Type 2 Header = '10111'
10	MUX2_REV_FCH_10	14400 bps, MuxPDU Type 2 Header = '11000'
11	MUX2_REV_FCH_11	7200 bps, MuxPDU Type 2 Header = '0' or null traffic MuxPDU
12	MUX2_REV_FCH_12	7200 bps, MuxPDU Type 2 Header = '1000'
13	MUX2_REV_FCH_13	7200 bps, MuxPDU Type 2 Header = '1001'
14	MUX2_REV_FCH_14	7200 bps, MuxPDU Type 2 Header = '1010'
15	MUX2_REV_FCH_15	7200 bps, MuxPDU Type 2 Header = '1011'
16	MUX2_REV_FCH_16	7200 bps, MuxPDU Type 2 Header = '1100'
17	MUX2_REV_FCH_17	7200 bps, MuxPDU Type 2 Header = '1101'
18	MUX2_REV_FCH_18	7200 bps, MuxPDU Type 2 Header = '1110'
19	MUX2_REV_FCH_19	3600 bps, MuxPDU Type 2 Header = '0' or null traffic MuxPDU
20	MUX2_REV_FCH_20	3600 bps, MuxPDU Type 2 Header = '100'
21	MUX2_REV_FCH_21	3600 bps, MuxPDU Type 2 Header = '101'
22	MUX2_REV_FCH_22	3600 bps, MuxPDU Type 2 Header = '110'
23	MUX2_REV_FCH_23	3600 bps, MuxPDU Type 2 Header = '111'
24	MUX2_REV_FCH_24	1800 bps, MuxPDU Type 2 Header = '0' or null traffic MuxPDU
25	MUX2_REV_FCH_25	1800 bps, MuxPDU Type 2 Header = '1'
26	MUX2_REV_FCH_26	reserved
27	MUX2_REV_FCH_27	reserved
28	MUX2_REV_FCH_5_ms	MuxPDU Type 4

2

3 2.2.3.1.2 Mobile Station Transmission Statistics for the DCCH

4 If the mobile station supports a DCCH, it shall maintain counters 1 through 5 and 15
5 in Table 24. If the mobile station supports secondary traffic on the DCCH, it shall also
6 maintain counters 11 through 14 in Table 24. If the mobile station supports MuxPDU
7 Type 4 on the DCCH, it shall also maintain counter 16 in Table 24.

1

Table 24. DCCH Transmission Counters for Multiplex Option 0x1

Counter Number	Counter Name	Description
1	MUX1_REV_DCCH_1	9600 bps, MuxPDU Type 1 Header = '0'
2	MUX1_REV_DCCH_2	9600 bps, MuxPDU Type 1 Header = '1000'
3	MUX1_REV_DCCH_3	9600 bps, MuxPDU Type 1 Header = '1001'
4	MUX1_REV_DCCH_4	9600 bps, MuxPDU Type 1 Header = '1010'
5	MUX1_REV_DCCH_5	9600 bps, MuxPDU Type 1 Header = '1011'
6	MUX1_REV_DCCH_6	reserved
7	MUX1_REV_DCCH_7	reserved
8	MUX1_REV_DCCH_8	reserved
9	MUX1_REV_DCCH_9	reserved
10	MUX1_REV_DCCH_10	reserved
11	MUX1_REV_DCCH_11	9600 bps, MuxPDU Type 1 Header = '1100'
12	MUX1_REV_DCCH_12	9600 bps, MuxPDU Type 1 Header = '1101'
13	MUX1_REV_DCCH_13	9600 bps, MuxPDU Type 1 Header = '1110'
14	MUX1_REV_DCCH_14	9600 bps, MuxPDU Type 1 Header = '1111'
15	MUX1_REV_DCCH_15	Null MuxPDU
16	MUX1_REV_DCCH_5_ms	MuxPDU Type 4

2

3

4

5

6

7

If the mobile station supports a DCCH and also supports multiplex option 0x2 on the DCCH, it shall maintain counters 1 through 5 and 27 in Table 25. If the mobile station also supports secondary traffic on the DCCH, it shall also maintain counters 6 through 10 in Table 25. If the mobile station supports MuxPDU Type 4 on the DCCH, it shall also maintain counter 28 in Table 25.

1

Table 25. DCCH Transmission Counters for Multiplex Option 0x2

Counter Number	Counter Name	Description
1	MUX2_REV_DCCH_1	14400 bps, MuxPDU Type 2 Header = '0'
2	MUX2_REV_DCCH_2	14400 bps, MuxPDU Type 2 Header = '10000'
3	MUX2_REV_DCCH_3	14400 bps, MuxPDU Type 2 Header = '10001'
4	MUX2_REV_DCCH_4	14400 bps, MuxPDU Type 2 Header = '10010'
5	MUX2_REV_DCCH_5	14400 bps, MuxPDU Type 2 Header = '10011'
6	MUX2_REV_DCCH_6	14400 bps, MuxPDU Type 2 Header = '10100'
7	MUX2_REV_DCCH_7	14400 bps, MuxPDU Type 2 Header = '10101'
8	MUX2_REV_DCCH_8	14400 bps, MuxPDU Type 2 Header = '10110'
9	MUX2_REV_DCCH_9	14400 bps, MuxPDU Type 2 Header = '10111'
10	MUX2_REV_DCCH_10	14400 bps, MuxPDU Type 2 Header = '11000'
11	MUX2_REV_DCCH_11	reserved
12	MUX2_REV_DCCH_12	reserved
13	MUX2_REV_DCCH_13	reserved
14	MUX2_REV_DCCH_14	reserved
15	MUX2_REV_DCCH_15	reserved
16	MUX2_REV_DCCH_16	reserved
17	MUX2_REV_DCCH_17	reserved
18	MUX2_REV_DCCH_18	reserved
19	MUX2_REV_DCCH_19	reserved
20	MUX2_REV_DCCH_20	reserved
21	MUX2_REV_DCCH_21	reserved
22	MUX2_REV_DCCH_22	reserved
23	MUX2_REV_DCCH_23	reserved
24	MUX2_REV_DCCH_24	reserved
25	MUX2_REV_DCCH_25	reserved
26	MUX2_REV_DCCH_26	reserved
27	MUX2_REV_DCCH_27	Null MuxPDU
28	MUX2_REV_DCCH_5_ms	MuxPDU Type 4

2

3 2.2.3.1.3 Mobile Station Transmission Statistics for the SCCH

4 If the mobile station supports multiplex option 0x3 or 0x4, it shall support counters 1
5 and 2 in Table 26. If the mobile station supports multiplex option 0x5 or 0x6, it shall
6 support counters 1 through 4 in Table 26. If the mobile station supports multiplex
7 option 0x7 or 0x8, it shall support counters 1 through 6 in Table 26. If the mobile
8 station supports multiplex option 0x9 or 0xa, it shall support counters 1 through 8 in
9 Table 26. If the mobile station supports multiplex option 0xb or 0xc, it shall support
10 counters 1 through 10 in Table 26. If the mobile station supports multiplex option 0xd
11 or 0xe, it shall support counters 1 through 12 in Table 26. If the mobile station
12 supports multiplex option 0xf or 0x10, it shall support counters 1 through 14 in Table
13 26.

1

Table 26. SCCH Transmission Counters

Counter Number	Counter Name	Description
1	SCCH1_REV_P	9600 bps, MuxPDU Type 1 Header = '0' or 14400 bps, MuxPDU Type 2 Header = '0'
2	SCCH1_REV_S	9600 bps, MuxPDU Type 1 Header = '1111' or 14400 bps, MuxPDU Type 2 Header = '10111'
3	SCCH2_REV_P	9600 bps, MuxPDU Type 1 Header = '0' or 14400 bps, MuxPDU Type 2 Header = '0'
4	SCCH2_REV_S	9600 bps, MuxPDU Type 1 Header = '1111' or 14400 bps, MuxPDU Type 2 Header = '10111'
5	SCCH3_REV_P	9600 bps, MuxPDU Type 1 Header = '0' or 14400 bps, MuxPDU Type 2 Header = '0'
6	SCCH3_REV_S	9600 bps, MuxPDU Type 1 Header = '1111' or 14400 bps, MuxPDU Type 2 Header = '10111'
7	SCCH4_REV_P	9600 bps, MuxPDU Type 1 Header = '0' or 14400 bps, MuxPDU Type 2 Header = '0'
8	SCCH4_REV_S	9600 bps, MuxPDU Type 1 Header = '1111' or 14400 bps, MuxPDU Type 2 Header = '10111'
9	SCCH5_REV_P	9600 bps, MuxPDU Type 1 Header = '0' or 14400 bps, MuxPDU Type 2 Header = '0'
10	SCCH5_REV_S	9600 bps, MuxPDU Type 1 Header = '1111' or 14400 bps, MuxPDU Type 2 Header = '10111'
11	SCCH6_REV_P	9600 bps, MuxPDU Type 1 Header = '0' or 14400 bps, MuxPDU Type 2 Header = '0'
12	SCCH6_REV_S	9600 bps, MuxPDU Type 1 Header = '1111' or 14400 bps, MuxPDU Type 2 Header = '10111'
13	SCCH7_REV_P	9600 bps, MuxPDU Type 1 Header = '0' or 14400 bps, MuxPDU Type 2 Header = '0'
14	SCCH7_REV_S	9600 bps, MuxPDU Type 1 Header = '1111' or 14400 bps, MuxPDU Type 2 Header = '10111'

2.2.3.1.4 Mobile Station Transmission Statistics for the SCH

3 If the mobile station supports **SCH1SCH0** and multiplex option 0x3 or 0x4, it shall
4 maintain counter 1 in Table 27. If the mobile station supports **SCH1SCH0** and
5 multiplex option 0x809, 0x80a, 0x905, or 0x906, it shall maintain counters 1 and 2 in
6 Table 27. If the mobile station supports **SCH1SCH0** and multiplex option 0x811, 0x812,
7 0x909, or 0x90a, it shall maintain counters 1 through 3 in Table 27. If the mobile
8 station supports **SCH1SCH0** and multiplex option 0x821, 0x822, 0x911, or 0x912, it
9 shall maintain counters 1 through 4 in Table 27. If the mobile station supports
10 **SCH1SCH0** and multiplex option 0x921 or 0x922, it shall maintain counters 1 through
11 5 in Table 27. If the mobile station supports LTU assembly for transmission on
12 **SCH1SCH0**, it shall maintain counter 6 in Table 27.

1 If the mobile station supports **SCH2SCH1** and multiplex option 0x3 or 0x4, it shall
 2 maintain counter 8 in Table 27. If the mobile station supports **SCH2SCH1** and
 3 multiplex option 0x809, 0x80a, 0x905, or 0x906, it shall maintain counters 8 and 9 in
 4 Table 27. If the mobile station supports **SCH2SCH1** and multiplex option 0x811, 0x812,
 5 0x909, or 0x90a, it shall maintain counters 8 through 10 in Table 27. If the mobile
 6 station supports **SCH2SCH1** and multiplex option 0x821, 0x822, 0x911, or 0x912, it
 7 shall maintain counters 8 through 11 in Table 27. If the mobile station supports
 8 **SCH2SCH1** and multiplex option 0x921 or 0x922, it shall maintain counters 8 through
 9 12 in Table 27. If the mobile station supports LTU assembly for transmission on
 10 **SCH2SCH1**, it shall maintain counter 13 in Table 27.

11 **Table 27. SCH Transmission Counters**

Counter Number	Counter Name	Description
1	SCH1SCH0_REV_1X	9600 bps or 14400 bps (1x SCH rate)
2	SCH1SCH0_REV_2X	19200 bps or 28800 bps (2x SCH rate)
3	SCH1SCH0_REV_4X	38400 bps or 57600 bps (4x SCH rate)
4	SCH1SCH0_REV_8X	76800 bps or 115200 bps (8x SCH rate)
5	SCH1SCH0_REV_16X	153600 bps (16x SCH rate)
6	SCH1SCH0_REV_LTU	number of LTUs delivered to the Physical Layer
7	SCH1SCH0_REV_LTUOK	reserved
8	SCH2SCH1_REV_1X	9600 bps or 14400 bps (1x SCH rate)
9	SCH2SCH1_REV_2X	19200 bps or 28800 bps (2x SCH rate)
10	SCH2SCH1_REV_4X	38400 bps or 57600 bps (4x SCH rate)
11	SCH2SCH1_REV_8X	76800 bps or 115200 bps (8x SCH rate)
12	SCH2SCH1_REV_16X	153600 bps (16x SCH rate)
13	SCH2SCH1_REV_LTU	number of LTUs delivered to the Physical Layer
14	SCH2SCH1_REV_LTUOK	reserved

12 **2.2.3.2 Mobile Station Reception Statistics**

13 For every Physical Layer SDU that the multiplex sublayer receives from the Physical
 14 Layer, the mobile station shall perform the following:

- 15 ● If the associated Physical Layer frame quality is sufficient, the mobile station shall
 16 count, by physical channel type, the number and type of Physical Layer SDU.
- 17 ● For a Physical Layer SCH SDU, if the multiplex sublayer performs LTU processing
 18 on the SDU, the mobile station shall count the total number of LTUs in the SDU
 19 and the number of successfully recovered LTUs.

20 Each counter used for this purpose shall be 24 bits long. The mobile station shall
 21 initialize each counter that it maintains to zero upon power-on. The mobile station shall
 22 not reinitialize any counter except upon command from the base station. Each counter
 23 shall be maintained modulo 2^{24} .

24 **2.2.3.2.1 Mobile Station Reception Statistics for the FCH**

25 The mobile station shall maintain counters 1 through 10 in Table 28. If the mobile
 26 station also supports secondary traffic on the FCH, it shall also maintain counters 11
 27 through 14 in Table 28. If the mobile station supports MuxPDU Type 4 on the FCH, it
 28 shall also maintain counter 16 in Table 28.

1

Table 28. FCH Reception Counters for Multiplex Option 0x1

Counter Number	Counter Name	Description
1	MUX1_FOR_FCH_1	9600 bps, MuxPDU Type 1 Header = '0' or null traffic MuxPDU
2	MUX1_FOR_FCH_2	9600 bps, MuxPDU Type 1 Header = '1000'
3	MUX1_FOR_FCH_3	9600 bps, MuxPDU Type 1 Header = '1001'
4	MUX1_FOR_FCH_4	9600 bps, MuxPDU Type 1 Header = '1010'
5	MUX1_FOR_FCH_5	9600 bps, MuxPDU Type 1 Header = '1011'
6	MUX1_FOR_FCH_6	4800 bps, MuxPDU Type 1 or null traffic MuxPDU
7	MUX1_FOR_FCH_7	2400 bps, MuxPDU Type 1 or null traffic MuxPDU
8	MUX1_FOR_FCH_8	1200 bps, MuxPDU Type 1 or null traffic MuxPDU
9	MUX1_FOR_FCH_9	9600 bps, Physical Layer frame with insufficient Physical Layer frame quality ²⁰
10	MUX1_FOR_FCH_10	Insufficient Physical Layer frame quality ²¹
11	MUX1_FOR_FCH_11	9600 bps, MuxPDU Type 1 Header = '1100'
12	MUX1_FOR_FCH_12	9600 bps, MuxPDU Type 1 Header = '1101'
13	MUX1_FOR_FCH_13	9600 bps, MuxPDU Type 1 Header = '1110'
14	MUX1_FOR_FCH_14	9600 bps, MuxPDU Type 1 Header = '1111'
15	MUX1_FOR_FCH_15	reserved
16	MUX1_FOR_FCH_5_ms	MuxPDU Type 4

2

3

4

5

6

7

8

If the mobile station supports multiplex option 0x2 on the FCH, it shall maintain counters 1 through 5, 11 through 14, 19 through 21, 24, and 26 in Table 29. If the mobile station also supports secondary traffic on the FCH, it shall also maintain counters 6 through 10, 15 through 18, 22 through 23, and 25 in Table 29. If the mobile station supports MuxPDU Type 4 on the FCH, it shall also maintain counter 28 in Table 29.

²⁰ This category is used when the Physical Layer frame quality is insufficient, but other parameters indicate a 9600 bps frame has been received.

²¹ This category is used when the Physical Layer frame's bit rate cannot be determined or when the error does not belong to category 9.

1

Table 29. FCH Reception Counters for Multiplex Option 0x2

Counter Number	Counter Name	Description
1	MUX2_FOR_FCH_1	14400 bps, MuxPDU Type 2 Header = '0' or null traffic MuxPDU
2	MUX2_FOR_FCH_2	14400 bps, MuxPDU Type 2 Header = '10000'
3	MUX2_FOR_FCH_3	14400 bps, MuxPDU Type 2 Header = '10001'
4	MUX2_FOR_FCH_4	14400 bps, MuxPDU Type 2 Header = '10010'
5	MUX2_FOR_FCH_5	14400 bps, MuxPDU Type 2 Header = '10011'
6	MUX2_FOR_FCH_6	14400 bps, MuxPDU Type 2 Header = '10100'
7	MUX2_FOR_FCH_7	14400 bps, MuxPDU Type 2 Header = '10101'
8	MUX2_FOR_FCH_8	14400 bps, MuxPDU Type 2 Header = '10110'
9	MUX2_FOR_FCH_9	14400 bps, MuxPDU Type 2 Header = '10111'
10	MUX2_FOR_FCH_10	14400 bps, MuxPDU Type 2 Header = '11000'
11	MUX2_FOR_FCH_11	7200 bps, MuxPDU Type 2 Header = '0' or null traffic MuxPDU
12	MUX2_FOR_FCH_12	7200 bps, MuxPDU Type 2 Header = '1000'
13	MUX2_FOR_FCH_13	7200 bps, MuxPDU Type 2 Header = '1001'
14	MUX2_FOR_FCH_14	7200 bps, MuxPDU Type 2 Header = '1010'
15	MUX2_FOR_FCH_15	7200 bps, MuxPDU Type 2 Header = '1011'
16	MUX2_FOR_FCH_16	7200 bps, MuxPDU Type 2 Header = '1100'
17	MUX2_FOR_FCH_17	7200 bps, MuxPDU Type 2 Header = '1101'
18	MUX2_FOR_FCH_18	7200 bps, MuxPDU Type 2 Header = '1110'
19	MUX2_FOR_FCH_19	3600 bps, MuxPDU Type 2 Header = '0' or null traffic MuxPDU
20	MUX2_FOR_FCH_20	3600 bps, MuxPDU Type 2 Header = '100'
21	MUX2_FOR_FCH_21	3600 bps, MuxPDU Type 2 Header = '101'
22	MUX2_FOR_FCH_22	3600 bps, MuxPDU Type 2 Header = '110'
23	MUX2_FOR_FCH_23	3600 bps, MuxPDU Type 2 Header = '111'
24	MUX2_FOR_FCH_24	1800 bps, MuxPDU Type 2 Header = '0' or null traffic MuxPDU
25	MUX2_FOR_FCH_25	1800 bps, MuxPDU Type 2 Header = '1'
26	MUX2_FOR_FCH_26	Insufficient Physical Layer frame quality ²²
27	MUX2_FOR_FCH_27	reserved
28	MUX2_FOR_FCH_5_ms	MuxPDU Type 4

2 **2.2.3.2.2 Mobile Station Reception Statistics for the DCCH**

3 If the mobile station supports a DCCH, it shall maintain counters 1 through 5, 10, and
4 15 in Table 30. If the mobile station supports secondary traffic on the DCCH, it shall
5 also maintain counters 11 through 14 in Table 30. If the mobile station supports
6 MuxPDU Type 4 on the DCCH, it shall also maintain counter 16 in Table 30.

²² This category is used when the Physical Layer frame's bit rate cannot be determined or when errors are detected.

1

Table 30. DCCH Reception Counters for Multiplex Option 0x1

Counter Number	Counter Name	Description
1	MUX1_FOR_DCCH_1	9600 bps, MuxPDU Type 1 Header = '0'
2	MUX1_FOR_DCCH_2	9600 bps, MuxPDU Type 1 Header = '1000'
3	MUX1_FOR_DCCH_3	9600 bps, MuxPDU Type 1 Header = '1001'
4	MUX1_FOR_DCCH_4	9600 bps, MuxPDU Type 1 Header = '1010'
5	MUX1_FOR_DCCH_5	9600 bps, MuxPDU Type 1 Header = '1011'
6	MUX1_FOR_DCCH_6	Reserved
7	MUX1_FOR_DCCH_7	Reserved
8	MUX1_FOR_DCCH_8	Reserved
9	MUX1_FOR_DCCH_9	Reserved
10	MUX1_FOR_DCCH_10	Insufficient Physical Layer frame quality
11	MUX1_FOR_DCCH_11	9600 bps, MuxPDU Type 1 Header = '1100'
12	MUX1_FOR_DCCH_12	9600 bps, MuxPDU Type 1 Header = '1101'
13	MUX1_FOR_DCCH_13	9600 bps, MuxPDU Type 1 Header = '1110'
14	MUX1_FOR_DCCH_14	9600 bps, MuxPDU Type 1 Header = '1111'
15	MUX1_FOR_DCCH_15	Null MuxPDU
16	MUX1_FOR_DCCH_5_ms	MuxPDU Type 4

2

3

4

5

6

7

If the mobile station supports a DCCH and also supports multiplex option 0x2 on the DCCH, it shall maintain counters 1 through 5, 26, and 27 Table 31. If the mobile station also supports secondary traffic on the DCCH, it shall also maintain counters 6 through 10 in Table 31. If the mobile station supports MuxPDU Type 4 on the DCCH, it shall also maintain counter 28 in Table 31.

1

Table 31. DCCH Reception Counters for Multiplex Option 0x2

Counter Number	Counter Name	Description
1	MUX2_FOR_DCCH_1	14400 bps, MuxPDU Type 2 Header = '0'
2	MUX2_FOR_DCCH_2	14400 bps, MuxPDU Type 2 Header = '10000'
3	MUX2_FOR_DCCH_3	14400 bps, MuxPDU Type 2 Header = '10001'
4	MUX2_FOR_DCCH_4	14400 bps, MuxPDU Type 2 Header = '10010'
5	MUX2_FOR_DCCH_5	14400 bps, MuxPDU Type 2 Header = '10011'
6	MUX2_FOR_DCCH_6	14400 bps, MuxPDU Type 2 Header = '10100'
7	MUX2_FOR_DCCH_7	14400 bps, MuxPDU Type 2 Header = '10101'
8	MUX2_FOR_DCCH_8	14400 bps, MuxPDU Type 2 Header = '10110'
9	MUX2_FOR_DCCH_9	14400 bps, MuxPDU Type 2 Header = '10111'
10	MUX2_FOR_DCCH_10	14400 bps, MuxPDU Type 2 Header = '11000'
11	MUX2_FOR_DCCH_11	Reserved
12	MUX2_FOR_DCCH_12	Reserved
13	MUX2_FOR_DCCH_13	Reserved
14	MUX2_FOR_DCCH_14	Reserved
15	MUX2_FOR_DCCH_15	Reserved
16	MUX2_FOR_DCCH_16	Reserved
17	MUX2_FOR_DCCH_17	Reserved
18	MUX2_FOR_DCCH_18	Reserved
19	MUX2_FOR_DCCH_19	Reserved
20	MUX2_FOR_DCCH_20	Reserved
21	MUX2_FOR_DCCH_21	Reserved
22	MUX2_FOR_DCCH_22	Reserved
23	MUX2_FOR_DCCH_23	Reserved
24	MUX2_FOR_DCCH_24	Reserved
25	MUX2_FOR_DCCH_25	Reserved
26	MUX2_FOR_DCCH_26	Insufficient Physical Layer frame quality
27	MUX2_FOR_DCCH_27	Null Physical Layer frame
28	MUX2_FOR_DCCH_5_ms	MuxPDU Type 4

2

2.2.3.2.3 Mobile Station Reception Statistics for the SCCH

3 If the mobile station supports multiplex option 0x3 or 0x4, it shall support counters 1
4 and 2 in Table 32. If the mobile station supports multiplex option 0x5 or 0x6, it shall
5 support counters 1 through 4 in Table 32. If the mobile station supports multiplex
6 option 0x7 or 0x8, it shall support counters 1 through 6 in Table 32. If the mobile
7 station supports multiplex option 0x9 or 0xa, it shall support counters 1 through 8 in
8 Table 32. If the mobile station supports multiplex option 0xb or 0xc, it shall support
9 counters 1 through 10 in Table 32. If the mobile station supports multiplex option 0xd
10 or 0xe, it shall support counters 1 through 12 in Table 32. If the mobile station
11 supports multiplex option 0xf or 0x10, it shall support counters 1 through 14 in Table
12 32.

1

Table 32. SCCH Reception Counters

Counter Number	Counter Name	Description
1	SCCH1_FOR_P	9600 bps, MuxPDU Type 1 Header = '0' or 14400 bps, MuxPDU Type 2 Header = '0'
2	SCCH1_FOR_S	9600 bps, MuxPDU Type 1 Header = '1111' or 14400 bps, MuxPDU Type 2 Header = '10111'
3	SCCH2_FOR_P	9600 bps, MuxPDU Type 1 Header = '0' or 14400 bps, MuxPDU Type 2 Header = '0'
4	SCCH2_FOR_S	9600 bps, MuxPDU Type 1 Header = '1111' or 14400 bps, MuxPDU Type 2 Header = '10111'
5	SCCH3_FOR_P	9600 bps, MuxPDU Type 1 Header = '0' or 14400 bps, MuxPDU Type 2 Header = '0'
6	SCCH3_FOR_S	9600 bps, MuxPDU Type 1 Header = '1111' or 14400 bps, MuxPDU Type 2 Header = '10111'
7	SCCH4_FOR_P	9600 bps, MuxPDU Type 1 Header = '0' or 14400 bps, MuxPDU Type 2 Header = '0'
8	SCCH4_FOR_S	9600 bps, MuxPDU Type 1 Header = '1111' or 14400 bps, MuxPDU Type 2 Header = '10111'
9	SCCH5_FOR_P	9600 bps, MuxPDU Type 1 Header = '0' or 14400 bps, MuxPDU Type 2 Header = '0'
10	SCCH5_FOR_S	9600 bps, MuxPDU Type 1 Header = '1111' or 14400 bps, MuxPDU Type 2 Header = '10111'
11	SCCH6_FOR_P	9600 bps, MuxPDU Type 1 Header = '0' or 14400 bps, MuxPDU Type 2 Header = '0'
12	SCCH6_FOR_S	9600 bps, MuxPDU Type 1 Header = '1111' or 14400 bps, MuxPDU Type 2 Header = '10111'
13	SCCH7_FOR_P	9600 bps, MuxPDU Type 1 Header = '0' or 14400 bps, MuxPDU Type 2 Header = '0'
14	SCCH7_FOR_S	9600 bps, MuxPDU Type 1 Header = '1111' or 14400 bps, MuxPDU Type 2 Header = '10111'

2 2.2.3.2.4 Mobile Station Reception Statistics for the SCH

3 If the mobile station supports ~~SCH1~~SCH0 and multiplex option 0x3 or 0x4, it shall
4 maintain counter 1 in Table 33. If the mobile station supports ~~SCH1~~SCH0 and
5 multiplex option 0x809, 0x80a, 0x905, or 0x906, it shall maintain counters 1 and 2 in
6 Table 33. If the mobile station supports ~~SCH1~~SCH0 and multiplex option 0x811, 0x812,
7 0x909, or 0x90a, it shall maintain counters 1 through 3 in Table 33. If the mobile
8 station supports ~~SCH1~~SCH0 and multiplex option 0x821, 0x822, 0x911, or 0x912, it
9 shall maintain counters 1 through 4 in Table 33. If the mobile station supports
10 ~~SCH1~~SCH0 and multiplex option 0x921 or 0x922, it shall maintain counters 1 through
11 5 in Table 33. If the mobile station supports LTU reception on ~~SCH1~~SCH0, it shall
12 maintain counters 6 and 7 in Table 33.

1 If the mobile station supports SCH2SCH1 and multiplex option 0x3 or 0x4, it shall
 2 maintain counter 8 in Table 33. If the mobile station supports SCH2SCH1 and
 3 multiplex option 0x809, 0x80a, 0x905, or 0x906, it shall maintain counters 8 and 9 in
 4 Table 33. If the mobile station supports SCH2SCH1 and multiplex option 0x811, 0x812,
 5 0x909, or 0x90a, it shall maintain counters 8 through 10 in Table 33. If the mobile
 6 station supports SCH2SCH1 and multiplex option 0x821, 0x822, 0x911, or 0x912, it
 7 shall maintain counters 8 through 11 in Table 33. If the mobile station supports
 8 SCH2SCH1 and multiplex option 0x921 or 0x922, it shall maintain counters 8 through
 9 12 in Table 33. If the mobile station supports LTU reception on SCH2SCH1, it shall
 10 maintain counters 13 and 14 in Table 33.

11 **Table 33. SCH Reception Counters**

Counter Number	Counter Name	Description
1	<u>SCH1SCH0</u> _FOR_1X	9600 bps or 14400 bps (1x SCH rate)
2	<u>SCH1SCH0</u> _FOR_2X	19200 bps or 28800 bps (2x SCH rate)
3	<u>SCH1SCH0</u> _FOR_4X	38400 bps or 57600 bps (4x SCH rate)
4	<u>SCH1SCH0</u> _FOR_8X	76800 bps or 115200 bps (8x SCH rate)
5	<u>SCH1SCH0</u> _FOR_16X	153600 bps (16x SCH rate)
6	<u>SCH1SCH0</u> _FOR_LTU	number of LTUs received from the Physical Layer
7	<u>SCH1SCH0</u> _FOR_LTUOK	number of LTUs received from the Physical Layer with a correct CRC
8	<u>SCH2SCH1</u> _FOR_1X	9600 bps or 14400 bps (1x SCH rate)
9	<u>SCH2SCH1</u> _FOR_2X	19200 bps or 28800 bps (2x SCH rate)
10	<u>SCH2SCH1</u> _FOR_4X	38400 bps or 57600 bps (4x SCH rate)
11	<u>SCH2SCH1</u> _FOR_8X	76800 bps or 115200 bps (8x SCH rate)
12	<u>SCH2SCH1</u> _FOR_16X	153600 bps (16x SCH rate)
13	<u>SCH2SCH1</u> _FOR_LTU	number of LTUs received from the Physical Layer
14	<u>SCH2SCH1</u> _FOR_LTUOK	number of LTUs received from the Physical Layer with a correct CRC

12

1

2 No text.

3