

1  
2  
3  
4  
5  
6  
7  
8  
9  
10  
11  
12  
13  
14  
15  
16  
17  
18  
19  
20  
21

**3GPP2 A.S0012-C**  
**Version 2.0**  
**Date: December 2005**



**3RD GENERATION  
PARTNERSHIP  
PROJECT 2  
"3GPP2"**

---

# Interoperability Specification (IOS) for cdma2000 Access Network Interfaces — Part 2 Transport

## **(3G-IOS v5.0.1)**



# Table of Contents

1  
2  
3  
4  
5  
6  
7  
8  
9  
10  
11  
12  
13  
14  
15  
16  
17  
18  
19  
20  
21  
22  
23  
24  
25  
26  
27  
28  
29  
30  
31  
32  
33  
34  
35  
36  
37  
38  
39  
40  
41  
42  
43  
44  
45  
46  
47  
48  
49  
50  
51  
52  
53  
54  
55

|           |  |    |
|-----------|--|----|
| 1.0       | Introduction .....   | 1  |
| 1.1       | Overview .....   | 1  |
| 1.1.1     | Purpose .....  | 1  |
| 1.1.2     | Scope .....  | 1  |
| 1.2       | References .....   | 1  |
| 1.2.1     | 3GPP2 .....  | 1  |
| 1.2.2     | Standards Committee T1 .....   | 2  |
| 1.2.3     | International Telecommunications Union - Telecommunications Sector (ITU-T) ..... | 2  |
| 1.2.4     | Other .....  | 2  |
| 1.3       | Terminology .....  | 4  |
| 1.3.1     | Acronyms .....   | 4  |
| 1.3.2     | Definitions .....  | 6  |
| 2.0       | General Protocol Requirements .....  | 7  |
| 2.1       | Physical Layer (Layer 1) .....   | 7  |
| 2.2       | Link Layer (Layer 2) .....   | 8  |
| 2.3       | Use of ATM .....   | 9  |
| 2.3.1     | ATM Adaptation Layer .....   | 9  |
| 2.3.2     | Use of ATM AAL5 for Transmission of IP Datagrams .....                           | 9  |
| 2.4       | IP Transport Considerations .....  | 9  |
| 2.4.1     | IP Topologies .....  | 9  |
| 2.4.2     | IP Network and Transport Specifications (Layers 3/4) .....                       | 10 |
| 2.4.2.1   | Addressing .....   | 10 |
| 2.4.2.2   | Routing .....  | 10 |
| 2.4.2.3   | Flow Association .....   | 10 |
| 2.4.3     | IP Performance Specifications .....  | 10 |
| 2.4.4     | IP Quality of Service (QoS) Framework .....                                      | 10 |
| 2.4.5     | IP Security Framework Specifications .....                                       | 11 |
| 2.5       | Use of TCP .....   | 11 |
| 2.5.1     | Message Delimiting in TCP .....  | 11 |
| 2.5.2     | TCP Connection Establishment .....   | 13 |
| 2.5.3     | TCP Connection Release .....   | 13 |
| 2.6       | Use of GRE .....   | 13 |
| 2.6.1     | GRE Attributes .....   | 16 |
| 2.6.1.1   | Short Data Indicator .....   | 16 |
| 2.6.1.2   | Flow Control Indication .....  | 16 |
| 2.6.2     | Relationship of GRE tunnel to Quality of Service .....                           | 17 |
| 2.6.3     | GRE Protocol Usage for VoIP SOs .....  | 18 |
| 2.7       | Use of RTP .....   | 18 |
| 2.8       | Use of SUA .....   | 18 |
| 2.9       | Base Station Application Part .....  | 18 |
| 2.9.1     | The BS Management Application Part .....   | 19 |
| 2.9.2     | The Direct Transfer Application Part .....                                       | 19 |
| 2.10      | Use of SCTP .....  | 19 |
| 3.0       | Interface Specific Protocol Requirements .....                                   | 21 |
| 3.1       | A1, A2, and A5 Interfaces .....  | 21 |
| 3.1.1     | Signaling Connection Transport Protocol Options .....                            | 21 |
| 3.1.2     | User Traffic Connection Transport Protocol Options .....                         | 22 |
| 3.1.3     | Use of ANSI SS7 Transport (Layer 2) .....  | 22 |
| 3.1.3.1   | Field of Application .....   | 23 |
| 3.1.3.2   | Message Transfer Part .....  | 23 |
| 3.1.3.2.1 | General .....  | 23 |
| 3.1.3.2.2 | Level 1 (Chapter 2 of [21]) .....  | 23 |
| 3.1.3.2.3 | Level 2 (Chapter 3 of [21]) .....  | 24 |

|    |             |  |    |
|----|-------------|--|----|
| 1  | 3.1.3.2.4   | Level 3 (Chapter 4 of [21])                              | 24 |
| 2  | 3.1.3.2.5   | Testing and Maintenance (Chapter 7 of [21])              | 27 |
| 3  | 3.1.3.2.6   | Interface Functions                                      | 27 |
| 4  | 3.1.3.2.7   | Overload Control (Message Throughput Congestion)         | 27 |
| 5  | 3.1.3.3     | SCCP Transport Layer Specification (SCCP Functions)      | 27 |
| 6  | 3.1.3.3.1   | Overview   | 27 |
| 7  | 3.1.3.3.2   | Primitives (Chapter 1 of [22])                           | 28 |
| 8  | 3.1.3.3.3   | SCCP Messages (Chapter 2 of [22])                        | 29 |
| 9  | 3.1.3.3.4   | SCCP Formats and Codes (Chapter 3 of [22])               | 30 |
| 10 | 3.1.3.3.5   | SCCP Procedures (Chapter 4 of [22])                      | 31 |
| 11 | 3.1.3.4     | Use of the SCCP  | 32 |
| 12 | 3.1.3.4.1   | Connection Establishment                                 | 32 |
| 13 | 3.1.3.4.1.1 | Establishment Procedure - Case 1                         | 33 |
| 14 | 3.1.3.4.1.2 | Establishment Procedure - Case 2                         | 34 |
| 15 | 3.1.3.4.2   | Connection Release                                       | 35 |
| 16 | 3.1.3.4.3   | Abnormal SCCP Release                                    | 36 |
| 17 | 3.1.3.4.3.1 | SCCP Release by BS: Loss of SCCP Connection Information  | 36 |
| 18 | 3.1.3.4.3.2 | SCCP Release by MSC: Loss of SCCP Connection Information | 37 |
| 19 | 3.1.3.4.4   | SCCP Reference Generation Philosophy                     | 37 |
| 20 | 3.1.3.4.5   | SCCP Transfer of DTAP and BSMAP Messages                 | 38 |
| 21 | 3.2         | A1p and A2p Interfaces                                   | 42 |
| 22 | 3.2.1       | Performance Specifications                               | 42 |
| 23 | 3.2.2       | A1p Transport Protocol                                   | 42 |
| 24 | 3.2.2.1     | Physical Layer (L1) Specification for A1p                | 42 |
| 25 | 3.2.2.2     | Layer 2 Specification for A1p                            | 42 |
| 26 | 3.2.2.3     | Use of IP for A1p  | 43 |
| 27 | 3.2.2.4     | QoS Specifications for A1p                               | 43 |
| 28 | 3.2.2.5     | Security Specifications for A1p                          | 43 |
| 29 | 3.2.2.6     | Use of the SUA for A1p                                   | 43 |
| 30 | 3.2.2.6.1   | SUA Connection Establishment                             | 43 |
| 31 | 3.2.2.6.1.1 | Establishment Procedure - Case 1                         | 44 |
| 32 | 3.2.2.6.1.2 | Establishment Procedure - Case 2                         | 45 |
| 33 | 3.2.2.6.2   | Connection Release                                       | 46 |
| 34 | 3.2.2.6.3   | Abnormal SUA Release                                     | 47 |
| 35 | 3.2.2.6.3.1 | SUA Release by BS: Loss of SUA Connection Information    | 47 |
| 36 | 3.2.2.6.3.2 | SUA Release by MSCe: Loss of SUA Connection Information  | 48 |
| 37 | 3.2.2.6.4   | SUA Transfer of DTAP and BSMAP Messages                  | 48 |
| 38 | 3.2.2.7     | Base Station Application Part on A1p                     | 52 |
| 39 | 3.2.2.8     | Use of SCTP  | 52 |
| 40 | 3.2.3       | A2p User Traffic Transport Protocol                      | 52 |
| 41 | 3.2.3.1     | Physical Layer (L1) Specification for A2p                | 54 |
| 42 | 3.2.3.2     | Layer 2 Specification for A2p                            | 54 |
| 43 | 3.2.3.3     | Use of IP for A2p  | 54 |
| 44 | 3.2.3.4     | QoS Specifications for A2p                               | 54 |
| 45 | 3.2.3.5     | Security Specifications for A2p                          | 55 |
| 46 | 3.3         | A3 and A7 Interfaces                                     | 55 |
| 47 | 3.3.1       | Performance Specifications                               | 55 |
| 48 | 3.3.1.1     | Performance Specification for IP Protocol Stacks         | 56 |
| 49 | 3.3.2       | A3 User Traffic Transport Requirements                   | 57 |
| 50 | 3.3.2.1     | ATM-Based User Traffic Transport                         | 57 |
| 51 | 3.3.2.1.1   | Physical Layer (L1) Specification                        | 57 |
| 52 | 3.3.2.1.2   | Use of ATM   | 58 |
| 53 | 3.3.2.1.3   | Use of AAL2  | 58 |
| 54 | 3.3.2.2     | IP-Based User Traffic Transport                          | 58 |
| 55 | 3.3.2.2.1   | Physical Layer (L1) Specification                        | 58 |
| 56 | 3.3.2.2.2   | Layer 2 Specification                                    | 58 |

|    |           |   |    |
|----|-----------|---|----|
| 1  | 3.3.2.2.3 | Use of IP .....                             | 58 |
| 2  | 3.3.2.2.4 | QoS Specifications.....                     | 59 |
| 3  | 3.3.2.2.5 | Security Specifications.....                | 59 |
| 4  | 3.3.3     | A3/A7 Signaling Transport Requirements..... | 59 |
| 5  | 3.3.3.1   | ATM-Based Signaling Protocol Stack.....     | 60 |
| 6  | 3.3.3.1.1 | Use of Physical Layer .....                 | 60 |
| 7  | 3.3.3.1.2 | Use of ATM.....                             | 60 |
| 8  | 3.3.3.1.3 | Use of AAL5.....                            | 60 |
| 9  | 3.3.3.1.4 | Use of IP .....                             | 60 |
| 10 | 3.3.3.1.5 | Use of TCP .....                            | 60 |
| 11 | 3.3.3.2   | IP-Based Signaling Protocol Stack.....      | 60 |
| 12 | 3.3.3.2.1 | Use of Physical Layer .....                 | 61 |
| 13 | 3.3.3.2.2 | Layer 2 Specification .....                 | 61 |
| 14 | 3.3.3.2.3 | Use of IP .....                             | 61 |
| 15 | 3.3.3.2.4 | QoS Specifications.....                     | 61 |
| 16 | 3.3.3.2.5 | Security Specifications.....                | 61 |
| 17 | 3.3.3.2.6 | Use of SCTP .....                           | 62 |
| 18 | 3.4       | A8 and A9 Interfaces .....                  | 62 |
| 19 | 3.4.1     | Use of TCP .....                            | 63 |
| 20 | 3.4.2     | Use of UDP.....                             | 63 |
| 21 | 3.4.3     | Use of GRE.....                             | 63 |
| 22 | 3.5       | A10 and A11 Interface .....                 | 64 |
| 23 | 3.5.1     | Use of UDP.....                             | 65 |
| 24 | 3.5.2     | Use of GRE.....                             | 65 |
| 25 |           |   |    |
| 26 |           |   |    |

# List of Figures

1  
2  
3  
4  
5  
6  
7  
8  
9  
10  
11  
12  
13  
14  
15  
16  
17  
18  
19  
20  
21  
22  
23  
24  
25  
26  
27  
28  
29  
30  
31  
32  
33  
34  
35  
36  
37

|                      |  |    |
|----------------------|--|----|
| Figure 2-1           | Transport Network Reference Model .....                                | 7  |
| Figure 2.5.1-1       | Delimiting Messages in an IOS Application TCP Byte Stream.....         | 12 |
| Figure 2.6-1         | GRE Encapsulated User Traffic.....                                     | 14 |
| Figure 2.6-2         | 3GPP2 GRE Frame.....   | 14 |
| Figure 2.6-3         | Attribute Format .....   | 15 |
| Figure 2.9-1         | A1 or A1p Interface Signaling Protocol Reference Model.....            | 19 |
| Figure 3.1.1-1       | A1 Signaling Protocol Stack.....                                       | 22 |
| Figure 3.1.2-1       | A2 User Traffic Protocol Stacks .....                                  | 22 |
| Figure 3.1.2-2       | A5 User Traffic Protocol Stacks .....                                  | 22 |
| Figure 3.1.3.4.1.1-1 | SCCP Connection Establishment .....                                    | 33 |
| Figure 3.1.3.4.1.1-2 | SCCP Connection Establishment Refusal.....                             | 34 |
| Figure 3.1.3.4.1.2-1 | SCCP Connection Establishment During Handoff .....                     | 35 |
| Figure 3.1.3.4.1.2-2 | SCCP Connection Refusal During Handoff.....                            | 35 |
| Figure 3.1.3.4.3.1-1 | BS Initiated SCCP Release: BS Lost SCCP Connection Information .....   | 36 |
| Figure 3.1.3.4.3.2-1 | MSC Initiated SCCP Release: MSC Lost SCCP Connection Information ..... | 37 |
| Figure 3.1.3.4.4-1   | SLR/DLR Usage .....  | 38 |
| Figure 3.2.2-1       | A1p Signaling Protocol Stack.....                                      | 42 |
| Figure 3.2.2.6.1.1-1 | SUA Connection Establishment.....                                      | 44 |
| Figure 3.2.2.6.1-2   | SUA Connection Establishment Refusal .....                             | 45 |
| Figure 3.2.2.6.1.2-1 | SUA Connection Establishment During Handoff .....                      | 46 |
| Figure 3.2.2.6.1.2-2 | SUA Connection Refusal During Handoff.....                             | 46 |
| Figure 3.2.2.6.3.1-1 | BS Initiated SUA Release: BS Lost SUA Connection Information .....     | 47 |
| Figure 3.2.2.6.3.2-1 | MSCe Initiated SUA Release: MSCe Lost SUA Connection Information ..... | 48 |
| Figure 3.2.3-1       | .....  | 53 |
| Figure 3.2.3-2       | .....  | 53 |
| Figure 3.2.3-3       | .....  | 54 |
| Figure 3.2.3-4       | .....  | 54 |
| Figure 3.3.2-1       | A3 User Traffic Protocol Stack .....                                   | 57 |
| Figure 3.3.3-1       | A3 and A7 Signaling Protocol Stack .....                               | 59 |
| Figure 3.4-1         | A9 Signaling Protocol Stack.....                                       | 62 |
| Figure 3.4-2         | A8 User Traffic Protocol Stack .....                                   | 63 |
| Figure 3.5-1         | A11 Signaling Protocol Stack.....                                      | 64 |
| Figure 3.5-2         | A10 User Traffic Protocol Stack.....                                   | 65 |

## List of Tables

1  
2  
3  
4  
5  
6  
7  
8  
9  
10

|                   |   |    |
|-------------------|---|----|
| Table 3.1.3.4.5-1 | Use of the User Data Field in SCCP Frames .....                   | 38 |
| Table 3.1.3.4.5-2 | Use of SCCP for BSMAP and DTAP Messages.....                      | 39 |
| Table 3.2.2.6.4-1 | Use of the User Data Field in SUA Frames .....                    | 49 |
| Table 3.2.2.6.4-2 | Use of SUA for BSMAP and DTAP Messages .....                      | 49 |
| Table 3.3.1-1     | Delay Budget Requirements .....                                   | 55 |
| Table 3.3.1.1-1   | A3/A7 Mapping Between Traffic Classes and Service-Level QoS ..... | 57 |

1  
2  
3  
4  
5

(This page intentionally left blank.)

## 1.0 Introduction

---

### 1.1 Overview

---

This document contains the protocol definitions and transport requirements for the interfaces defined in this specification.

#### 1.1.1 Purpose

---

The purpose of this document is to describe the transport protocols and protocol stacks used on the interfaces, which make up the logical network model, and to indicate any unique aspects of these protocols that are relevant to the Interoperability Specification (IOS).

#### 1.1.2 Scope

---

This document contains generic and specific requirements for the IOS interfaces. The document contains the generic protocol descriptions that are used through all of the IOS interfaces. In addition, protocol stack and transport network requirements for each IOS interface are contained in this document. Details of the IOS application and signaling layer messages are contained in the respective interface documents [14], [15], [16], and [17].

## 1.2 References

---

### 1.2.1 3GPP2

---

- [1~7] Reserved.
- [8] Reserved.
- [9] Reserved.
- [10] Reserved.
- [11] 3GPP2 A.S0011-C, *Interoperability Specification (IOS) for cdma2000 Access Network Interfaces – Part 1 Overview*, February 2005.
- [12] Reserved.
- [13] 3GPP2 A.S0013-C, *Interoperability Specification (IOS) for cdma2000 Access Network Interfaces – Part 3 Features*, February 2005.
- [14] 3GPP2 A.S0014-C, *Interoperability Specification (IOS) for cdma2000 Access Network Interfaces – Part 4 (A1, A1p, A2, and A5 Interfaces)*, February 2005.
- [15] 3GPP2 A.S0015-C, *Interoperability Specification (IOS) for cdma2000 Access Network Interfaces – Part 5 (A3 and A7 Interfaces)*, February 2005.
- [16] 3GPP2 A.S0016-C, *Interoperability Specification (IOS) for cdma2000 Access Network Interfaces – Part 6 (A8 and A9 Interfaces)*, February 2005.
- [17] 3GPP2 A.S0017-C, *Interoperability Specification (IOS) for cdma2000 Access Network Interfaces – Part 7 (A10 and A11 Interfaces)*, February 2005.
- [18] 3GPP2 C.S0047-0, Version 1.0, *Link-Layer Assisted Service Options for Voice-over-IP: Header Removal (SO60) and Robust Header Compression (SO61)*, April 14, 2003.
- [19] 3GPP2 N.S0019, *Intersystem Link Protocol*, January 28, 2000.

## 1.2.2 Standards Committee T1

---

- [20] ANSI T1.101-1999, *Synchronization Interface Standard, February 1999.*
- [21] ANSI T1.111-2001, *Signaling System No. 7 (SS7) - Message Transfer Part (Includes T1.111a-2002), February 2001.*
- [22] ANSI T1.112-2001, *Signaling System No. 7 (SS7) - Signaling Connection Control Part (SCCP) (Revision of T1.112-1996), August 2001.*
- [23] ANSI T1.627 – 1993 (R1999), *B-ISDN - ATM Layer Functionality and Specification, July 1993, Reaffirmed 1999.*
- [24] ANSI T1.105 – 2001, *Synchronous Optical Network (SONET) – Basic Description Including Multiplex Structure, Rates and Formats (Includes T1.105a-2002, May 2001.*

## 1.2.3 International Telecommunications Union - Telecommunications Sector (ITU-T)

---

- [25] ITU-T Recommendation G.707, *Network Node Interface for the Synchronous Digital Hierarchy (SDH), 1996.*
- [26] ITU-T Recommendation Q.2931, *Broadband-Integrated Services Digital Network (B-ISDN) Digital Subscriber Signaling No. 2 (DSS2) User-Network Interface Layer 3 Specification for Basic Call/Connection Control, 1995.*

## 1.2.4 Other

---

- [27] Internet Engineering Task Force, *RFC 768 – User Datagram Protocol (UDP), 1980.*
- [28] Internet Engineering Task Force, *RFC 791 – Internet Protocol (IP), 1981.*
- [29] Internet Engineering Task Force, *RFC 793 – Transmission Control Protocol (TCP), 1981.*
- [30] Internet Engineering Task Force, *RFC 1483 – Multiprotocol Encapsulation over ATM Adaptation Layer 5, 1993.*
- [31] Internet Engineering Task Force, *RFC 2002 – IP Mobility Support Specification, 1996.*
- [32] Internet Engineering Task Force, *RFC 2225 – Classical IP and ARP over ATM, 1998.*
- [33] Internet Engineering Task Force, *RFC 2475 – An Architecture for Differentiated Services, December 1998.*
- [34] Internet Engineering Task Force, *RFC 2658 – RTP Payload Format for PureVoice™ Audio, www.ietf.org, August 1999.*
- [35] Internet Engineering Task Force, *RFC 2784 – Generic Routing Encapsulation (GRE), 2000.*
- [36] Internet Engineering Task Force, *RFC 2833 – RTP Payload for DTMF Digits, Telephony Tones and Telephony Signals, www.ietf.org, May 2000.*
- [37] Internet Engineering Task Force, *RFC 2890 – Key and Sequence Number Extensions to GRE, September 2000.*
- [38] Internet Engineering Task Force, *RFC 2960 – Stream Control Transmission Protocol, October 2000.*
- [39] Internet Engineering Task Force, *RFC 3550 – RTP: A Transport Protocol for Real Time Applications, July 2003*
- [40] Internet Engineering Task Force, *RFC 3551 – RTP Profile for Audio and Video Conferences with Minimal Control, July 2003.*
- [41] Internet Engineering Task Force, *RFC 3558 – RTP Payload Format for Enhanced Variable Rate Codecs (EVRC) and Selectable Mode Vocoders (SMV), www.ietf.org, July 2003.*
- [42] Internet Engineering Task Force, *RFC 3868 – Signaling Connection Control Part User Adaptation Layer (SUA), October 2004.*

1  
2  
3  
4  
5  
6

[43] IEEE 802.3, *IEEE Standard for Information technology – Telecommunications and information exchange between systems – Local and metropolitan area networks – Specific requirements – Part 3: Carrier Sense Multiple Access with Collision Detection (CSMA/CD) Access Method and Physical Layer Specifications*, 2002.

## 1.3 Terminology

---

### 1.3.1 Acronyms

---

| <b>Acronym</b> | <b>Meaning</b>                           |
|----------------|--|
| 3GPP2          | 3rd Generation Partnership Project 2     |
| AAL2           | ATM Adaptation Layer type 2              |
| AAL5           | ATM Adaptation Layer type 5              |
| ADDS           | Application Data Delivery Service        |
| Ack            | Acknowledgement                          |
| AL             | Application Layer                        |
| ANSI           | American National Standards Institute    |
| ATM            | Asynchronous Transfer Mode               |
| BS             | Base Station                             |
| BSAP           | Base Station Application Part            |
| BSC            | Base Station Controller                  |
| BSMAP          | Base Station Management Application Part |
| BTS            | Base Transceiver System                  |
| CC             | Connection Confirm                       |
| CDMA           | Code Division Multiple Access            |
| CIC            | Circuit Identity Code                    |
| CLDT           | Connectionless Data Transfer (SUA)       |
| CM             | Connection Management                    |
| COAK           | Connection Acknowledge (SUA)             |
| CODT           | Connection Oriented Data Transfer (SUA)  |
| CORE           | Connection Request (SUA)                 |
| COREF          | Connection Refused (SUA)                 |
| CR             | Connection Request                       |
| CREF           | Connection Refused                       |
| DCCH           | Dedicated Control Channel                |
| DiffServ       | Differentiated Services                  |
| DLR            | Destination Local Reference              |
| DPC            | Destination Point Code                   |
| DS0            | Digital Signal Level 0                   |
| DSCP           | Differentiated Services Code Point       |
| DT1            | Data Transfer 1                          |
| DT2            | Data Form 2                              |
| DTAP           | Direct Transfer Application Part         |

| <b>Acronym</b> | <b>Meaning</b>   |
|----------------|--|
| E1             | E1-type Digital Carrier  |
| EIA            | Electronics Industry Association   |
| ESN            | Electronic Serial Number   |
| FCH            | Fundamental Channel  |
| GRE            | Generic Routing Encapsulation  |
| IMSI           | International Mobile Subscriber Identity   |
| IOS            | Interoperability Specification   |
| IP             | Internet Protocol  |
| IS             | Interim Standard   |
| ISD            | Interface Service Delay  |
| ISL            | Interface Service Packet Loss  |
| ISLP           | Intersystem Link Protocol  |
| IT             | Inactivity Test  |
| ITU-T          | International Telecommunications Union – Telecommunications Standardization Sector |
| kbps           | Kilobits per second  |
| L1             | Layer 1 (Physical Layer)   |
| L2             | Layer 2 (Link Layer)   |
| L3             | Layer 3 (Network Layer)  |
| LLC            | Logical Link Control   |
| LMSD           | Legacy MS Domain   |
| LSB            | Least Significant Bit  |
| Mbps           | Million Bits per Second  |
| MGW            | Media Gateway  |
| MS             | Mobile Station   |
| MSB            | Most Significant Bit   |
| MSC            | Mobile Switching Center  |
| MSCe           | Mobile Switching Center Emulation  |
| Msg            | Message  |
| MTP            | Message Transfer Part  |
| OAM&P          | Operation Administration Maintenance and Provisioning                              |
| OC3            | Optical Carrier Level 3  |
| PACA           | Priority Access and Channel Assignment   |
| PCF            | Packet Control Function  |
| PCM            | Pulse Code Modulation  |
| PDSN           | Packet Data Serving Node   |
| PLMN           | Public Land Mobile Network   |
| PPP            | Point to Point Protocol  |
| PVC            | Permanent Virtual Circuit  |
| QoS            | Quality of Service   |

| <b>Acronym</b> | <b>Meaning</b>  |
|----------------|---|
| RAN            | Radio Access Network                                      |
| RELCO          | Release Complete (SUA)                                    |
| RELRE          | Release Request (SUA)                                     |
| RFC            | Request For Comment                                       |
| RLC            | Release Complete (SCCP)                                   |
| RLSD           | Release (SCCP)  |
| RTP            | Real-time Transport Protocol                              |
| SCCP           | Signaling Connection Control Part                         |
| SCH            | Supplemental Channel                                      |
| SCTP           | Stream Control Transmission Protocol                      |
| SDU            | Service Data Unit (ATM), Selector/Distribution Unit (IOS) |
| SI             | Service Instance  |
| SID            | Session Identifier  |
| SLR            | Source Local Reference                                    |
| SLTM           | Signaling Link Test Message                               |
| SOG            | Subsystem Out-of-service Grant                            |
| SOR            | Subsystem Out-of-service                                  |
| SS7            | Signaling System Number 7                                 |
| SSN            | Subsystem Number  |
| STP            | Signaling Transfer Point                                  |
| SUA            | Signaling Connection Control Part User Adaptation Layer   |
| T1             | T1-type Digital Carrier                                   |
| T3             | T3-type Digital Carrier                                   |
| TCP            | Transmission Control Protocol                             |
| TIA            | Telecommunications Industry Association                   |
| TL             | Transport Layer   |
| UDI            | Unrestricted Digital Information                          |
| UDP            | User Datagram Protocol                                    |
| UDT            | Unit Data (SCCP)  |
| UNI            | User Network Interface                                    |
| VC             | Virtual Circuit   |
| Ver            | Version   |
| VoIP           | Voice over Internet Protocol                              |

1

2

### **1.3.2 Definitions**

---

3

Refer to [11] for definitions.

## 2.0 General Protocol Requirements

The Transport specification uses protocols and terminology for the interface in the IOS, that conform to the transport network reference model as outlined in Figure 2-1. Layer 1 is the physical layer. Layer 2 is the link layer. Layer 3 is the network layer, which may consist of several hops connected by routing or switching nodes. Figure 2-1 shows two hops but a network can have none or many hops. The transport layer is above L3 and is an end-to-end protocol. The transport layer (TL) is terminated at end nodes within the Radio Access Network (RAN). From a RAN perspective, the application layer (AL) consists of IOS signaling messages and bearer frames on the IOS interface. Note the transport network reference model may not be applicable to describe the protocol stack for user traffic.

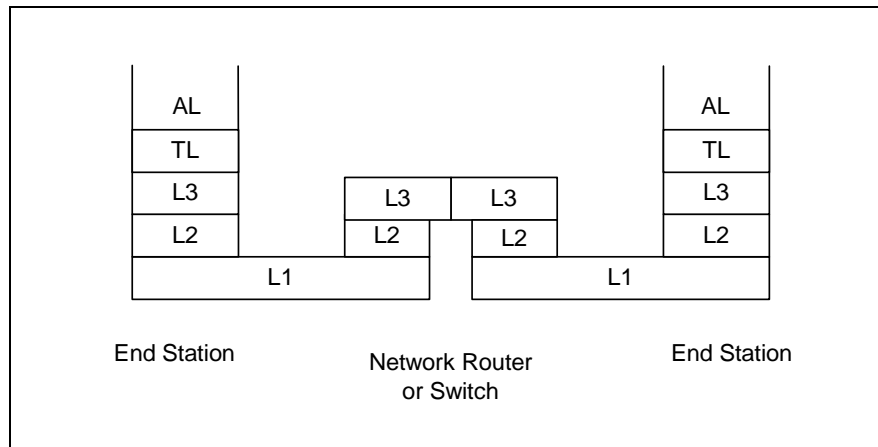

**Figure 2-1 Transport Network Reference Model**

The nodes comprising the RAN (e.g. Base Station (BS), Packet Control Function (PCF), Packet Data Service Node (PDSN) and Mobile Switching Centers (MSCs)) are often geographically distributed across and between areas of the transport network.

## 2.1 Physical Layer (Layer 1)

The IOS interfaces are based on the use of:

- T1 digital transmission system interfaces. Each 1.544 Mbps interface provides 24\*56 kbps or 24\*64 kbps channels or a 1.544 Mbps clear channel, which can be used for traffic or signaling as the operator requires. This type of interfaces can be full-duplex or half-duplex when it is used as a clear channel.
- E1 digital transmission interfaces consisting of 30\*64 kbps user channels or a 2.048 Mbps clear channel can also be used for traffic or signaling, as the operator requires, and as applicable to the network.
- T3 digital transmission interfaces supporting transmission rates of 43.232 Mbps.
- Optical Carrier Level 3 (OC3) digital transmission interfaces supporting transmission rates of 155.52 Mbps.
- Optical Carrier Level 12 (OC12) [24] and Synchronous Transfer Mode 4 (STM4) [25] digital transmission interfaces supporting transmission rates of 622.08 Mbps.
- Synchronous Transfer Mode 1 (STM1) [25] digital transmission interfaces supporting transmission rates of 155.52 Mbps.

- Asynchronous layer 1 protocols (e.g. 10/100BaseT, Gigabit Ethernet [43]) may be used on some IOS interfaces. These types of L1 protocols can be full or half-duplex, shared or dedicated. These types of L1 protocols may provide guaranteed bandwidth to the L2 protocol.

When the L1 protocol cannot guarantee the bandwidth to the L2 protocol, a mechanism should be provided by the L2 protocol that enables compliance to the performance specifications in this document if required.

Common physical interface standards are found in [20] and related references. For a list of references, refer to section 1.2.

## 2.2 Link Layer (Layer 2)

---

This standard uses different link layers on different interfaces. Message Transfer Part 2 and Asynchronous Transfer Mode (ATM) are used as the link layer (L2) protocol on some interfaces. For Internet Protocol (IP)-based protocol stacks in this specification, Layer 2 is left unspecified. In these cases requirements on L2 are invoked on an interface-by-interface basis as stated in the interface specific section of this document.

The following requirements may apply to an unspecified L2 implementation or protocol for IP:

- Bandwidth efficiency:** The L2 protocol provides functions to improve the bandwidth efficiency of transport network layer protocols when the physical layer (L1) consists of narrow-band (i.e., T1/E1 or lower rate) circuits. Bandwidth efficiency is defined here as the ratio of the total number of bits comprising a “packet” to the number of information (or payload) bits contained within that packet.
- Delay/jitter control:** The L2 protocol provides functions to manage queuing delay and inter-packet transmission time variation (jitter) for all packet sources (e.g., queuing, scheduling, prioritization). Queuing delay is defined here as the amount of time that a network layer (layer 3) packet waits at link layer (layer 2) for transmission on the physical interface (e.g. source bit-rate exceeds the transmission bit-rate of the destination connection associated with that packet).
- Multiplexing:** This function collects and concatenates eligible buffered frames/packet into one larger frame/packet reducing the impact of the protocol overhead for each frame. If the IP transport network employs this type of function, it shall be implemented in the link layer (L2) protocol. The implementation shall also permit enabling and disabling this feature on an L2 connection basis.
- Compression:** This function eliminates the need for transmission of certain header information (e.g., User Datagram Protocol (UDP) header, IP header, Point to Point Protocol (PPP) ID) for every packet in a given flow by making use of well-known or pre-negotiated connection state information. If the IP transport network employs this type of function, it shall be implemented in the link layer (L2) protocol. The implementation shall also permit enabling and disabling this feature on an L2 connection basis.
- Segmentation and re-assembly (SAR):** This function segments a packet (from the transport network or higher layers) into multiple packets/frames to control latency. If the IP transport network employs this type of function, it shall be implemented in the link layer (L2) or IP layer (L3) protocol. If implemented in L2, the implementation shall permit enabling and disabling this feature and controlling the respective frame size on an L2 connection basis as required by performance specifications of the connection.

- Error detection: The L2 protocol provides an error detection function for the L2 protocol fields. The L2 protocol may provide error detection for layer 2 payload data. The implementation shall permit enabling and disabling of this feature, if required by the L2 protocol, on a per L2 connection basis.
- Addressing: L2 addressing (e.g. MAC, VCI/VPI) supports a means of translating an IP address (unicast, multicast or broadcast) to an associated L2 address.

## 2.3 Use of ATM

---

The ATM Layer uses a basic 53 octet cell consisting of a 5 octet header and 48 octet payload. This standard uses the ATM Layer as specified in [23] without modification.

### 2.3.1 ATM Adaptation Layer

---

To make use of the basic cell transfer capability of the ATM Transport Layer in specific usages, various ATM Adaptation Layers (AALs) have been defined.

Within this standard, two AALs are used:

- AAL5 — for the transfer of signaling, and
- AAL2 — for the transfer of user traffic (voice/data) on A3 traffic subchannels.

Both ATM Adaptation Layer Type 5 (AAL5) and ATM Adaptation Layer Type 2 (AAL2) are used without modification in this standard. The Service Specific Segmentation and Reassembly sublayer for AAL2, as specified in [25], is used for segmentation and reassembly of AAL2 SDUs.

In this version of this standard, the functionality of other sublayers of AAL2 are not supported. Specifically, Service Specific Transmission Error Detection and Service Specific Assured Data Transfer are not included.

### 2.3.2 Use of ATM AAL5 for Transmission of IP Datagrams

---

Use of the AAL5 Permanent Virtual Circuit (PVC) and Switched Virtual Connection as the link layer of IP protocol stack shall follow [32]. Specification of either Logical Link Control (LLC) and Sub Network Attachment Point encapsulation or Virtual Channel (VC) multiplexing as per [30] is left to the discretion of operators and manufacturers.

## 2.4 IP Transport Considerations

---

The standard IP protocol, as defined in [28], shall be used for routing Internet Protocol packets.

### 2.4.1 IP Topologies

---

Within the IOS RAN, an IP transport network may be used to provide communication between the end nodes. This IP transport network itself may consist of transport nodes (routers, switches, etc) arranged into a number of different topologies (e.g. point-to-point, hierarchical, meshed, hub-spoke, star, etc). The transport network may also consist of one or more communication links that connect the end nodes to the transport network and the transport nodes to each other. The IP transport network may also consist of edge transport nodes that interface to other RANs or packet data networks providing security, address

1 translation and other functions specific to the type of network to which they are  
2 connected. There is no restriction on the number or types of topologies or devices that  
3 can be used to implement this RAN transport network.

## 4 **2.4.2 IP Network and Transport Specifications (Layers 3/4)**

---

5 This section provides a minimum set of requirements on transport and network layer  
6 (layer 3/4) interfaces to the BS, PCF, PDSN, MSCe, MGW or other network devices in  
7 the RAN.

### 8 **2.4.2.1 Addressing**

---

9 The IP transport network may support a class-less IP addressing scheme. This is  
10 necessary to allow flexibility in both routing and network design. To support this, a  
11 hierarchical addressing scheme shall be implemented with Variable Length Subnet  
12 Masks.

### 13 **2.4.2.2 Routing**

---

14 An implementation may choose one or more IP routing protocols as needed for non  
15 point-to-point network topologies.

### 16 **2.4.2.3 Flow Association**

---

17 Every logical element defined in an IOS interface that may be an information source or  
18 target may be individually addressable (e.g., via an IP address and UDP port number). In  
19 cases where logical sub-elements exist, the IP address and port number (such as for UDP,  
20 Transmission Control Protocol (TCP), or Stream Control Transmission Protocol (SCTP))  
21 may be used to uniquely identify a sub-element. Specific addressing requirements are set  
22 forth in the individual interface specifications.

23 A traffic flow (i.e., radio frame protocols, call control signaling, OAM&P, etc.) may be  
24 uniquely identified by the IP address of the destination element. In cases where logical  
25 sub-flows exist, the IP address and port number of the destination sub-element may be  
26 used to uniquely identify a flow. Mapping application flows to transport flows is  
27 specified by the individual IOS interfaces.

## 28 **2.4.3 IP Performance Specifications**

---

29 Each IOS interface may specify the performance it requires from the transport network.  
30 The following parameters may be specified by IOS interfaces that require performance  
31 specifications:

- 32 • Interface Service Delay (ISD): This is composed of the cumulative queuing,  
33 transmission, and propagation delays across the transport network between nodes  
34 supporting an IOS interface.
- 35 • Interface Service Packet Loss (ISL): This is the packet loss across the transport  
36 network between nodes supporting an IOS interface.

## 37 **2.4.4 IP Quality of Service (QoS) Framework**

---

38 To ensure that the transport network provides the necessary performance characteristics,  
39 the end nodes and transport network interfaces which require QoS shall support the

Differentiated Services (DiffServ) framework as specified in [33], with the following clarifications:

- The A1p/A2p, A3/A7, A8/A9 and A10/A11 network portions of the RAN transport network may be over-provisioned in comparison to the air interface (BS to MS) capacity, the A3/A7, A8/A9 and A10/A11 network traffic loads, or both. In case a RAN transport network is over-provisioned, the QoS framework in this section is not applicable to that transport network.
- Transport nodes (e.g., interior routers) shall support the following:
  - Per packet classification according to the Type of Service (TOS)/Differentiated Services Code Point (DSCP) field in the IPv4 header
  - One or more queuing disciplines to meet the interface's delay/jitter requirements.
- Edge transport nodes (e.g., border routers) shall support the following:
  - Policing disciplines to meet the traffic flow requirements.
- End host nodes (e.g., BS, PCF, PDSN's) shall support the following when required:
  - Per packet marking of a DSCP via the IPv4 TOS octet according to the prescribed DSCP value
  - Four or more traffic classes as defined by the relevant interface. The parameters of each class include mandatory and optional traffic types, service delay, and packet loss rate.

## 2.4.5 IP Security Framework Specifications

---

The IOS RAN may be realized as a managed network. In this case, it is assumed that all interfaces are physically secured as a minimum and any additional security measures are beyond the scope of this standard. For security measures specific to particular IOS interfaces, refer to [13].

## 2.5 Use of TCP

---

The standard TCP protocol, as described in [29], shall be used for establishing, using, and clearing TCP connections.

TCP connections for signaling may be set up on a per-call basis or signaling messages for multiple calls may be multiplexed on a single TCP connection.

The TCP protocol provides a reliable byte stream transfer. Therefore, a means needs to be provided for two application entities to delimit the messages sent between them. The technique for such delimitation is as follows.

### 2.5.1 Message Delimiting in TCP

---

TCP provides a reliable byte stream between two application entities. Because the protocol in this standard uses messages to communicate, these messages shall be delimited in the TCP byte stream. Such delimitation shall be done by means of a two byte flag field and a two byte length field inserted at the beginning of each message sent over a TCP connection. The flag field shall contain the hex value "F634". The purpose of the flag field is to facilitate verification of message boundaries and to speed up reestablishment of synchronization if synchronization of message boundaries is lost. Refer to Figure 2.5.1-1.

|               | 7                                       | 6 | 5 | 4 | 3 | 2 | 1     | 0 |
|---------------|---|---|---|---|---|---|-------|---|
| <b>Flag</b>   | 1                                       | 1 | 1 | 1 | 0 | 1 | 1     | 0 |
| <b>Flag</b>   | 0                                       | 0 | 1 | 1 | 0 | 1 | 0     | 0 |
| <b>Length</b> | (MSB)                                   |   |   |   |   |   |       |   |
| <b>Length</b> |   |   |   |   |   |   | (LSB) |   |
| <b>Msg</b>    | First Octet of IOS Application Message  |   |   |   |   |   |       |   |
|               | Second Octet of IOS Application Message |   |   |   |   |   |       |   |
|               | Third Octet of IOS Application Message  |   |   |   |   |   |       |   |
|               | ...                                     |   |   |   |   |   |       |   |
|               | Last Octet of IOS Application Message   |   |   |   |   |   |       |   |
| <b>Flag</b>   | 1                                       | 1 | 1 | 1 | 0 | 1 | 1     | 0 |
| <b>Flag</b>   | 0                                       | 0 | 1 | 1 | 0 | 1 | 0     | 0 |
| <b>Length</b> | (MSB)                                   |   |   |   |   |   |       |   |
| <b>Length</b> |   |   |   |   |   |   | (LSB) |   |
| <b>Msg</b>    | First Octet of IOS Application Message  |   |   |   |   |   |       |   |
|               | Second Octet of IOS Application Message |   |   |   |   |   |       |   |
|               | Third Octet of IOS Application Message  |   |   |   |   |   |       |   |
|               | ...                                     |   |   |   |   |   |       |   |
|               | Last Octet of IOS Application Message   |   |   |   |   |   |       |   |
| <b>Flag</b>   | 1                                       | 1 | 1 | 1 | 0 | 1 | 1     | 0 |
| <b>Flag</b>   | 0                                       | 0 | 1 | 1 | 0 | 1 | 0     | 0 |
| <b>Length</b> | (MSB)                                   |   |   |   |   |   |       |   |
| <b>Length</b> |   |   |   |   |   |   | (LSB) |   |
| <b>Msg</b>    | First Octet of IOS Application Message  |   |   |   |   |   |       |   |
|               | Second Octet of IOS Application Message |   |   |   |   |   |       |   |
|               | Third Octet of IOS Application Message  |   |   |   |   |   |       |   |
|               | ...                                     |   |   |   |   |   |       |   |

Figure 2.5.1-1 Delimiting Messages in an IOS Application TCP Byte Stream

1

2

## 2.5.2 TCP Connection Establishment

---

A new TCP connection is established when a signaling message is required to be exchanged over an interface and no such connection exists for that interface. Normal active-passive TCP connection establishment procedures are used.

## 2.5.3 TCP Connection Release

---

An existing TCP connection over an interface may be released when there are no more signaling messages to be exchanged over the interface. Normal TCP connection release procedures are used.

## 2.6 Use of GRE

---

The upper layer for the A8 and A10 interfaces is the Generic Routing Encapsulation (GRE) protocol as defined in [35] and extended in [37]. Refer to sections 3.4 and 3.5 for A8 and A10 protocol stack descriptions.

The A8 and A10 connections are used for the transport of user data for a packet data session. Link layer/network layer frames are carried between the BS, PCF and the PDSN encapsulated in GRE packets, which in turn are carried over IP. Each GRE packet is encapsulated in exactly one IP datagram. The BS Address, PCF Address and the PDSN Address are used in the source address and destination address fields of the IP header used with the GRE packet.

In the bearer traffic direction from the PDSN to the PCF, the key field in the GRE header contains the PCF Session Identifier (SID) that indicates to which A10 connection a particular payload packet belongs.

In the bearer traffic direction from the PCF to the PDSN, the key field in the GRE header contains the PDSN SID.

If the PDSN assigns a unique SID to each A10 connection, the PDSN SID can be used to identify to which A10 connection the packet belongs. Otherwise, the PDSN may use the combination of the PCF Address and the PDSN SID parameters of each received packet to identify the associated A10 connection.

In the bearer traffic direction from the PCF to the BS, the key field in the GRE header contains a unique BS identifier that indicates to which A8 connection a particular payload packet belongs.

In the bearer traffic direction from the BS to the PCF, the key field in the GRE header contains a unique PCF identifier that indicates to which A8 connection a particular payload packet belongs.

With the A8 and A10 connections in place, link layer/network layer packets pass over these connections in both directions between the BS and the PDSN using GRE framing. In the direction towards the BS, the PDSN encapsulates the link/network layer frames in GRE frames and sends them on the IP connection between the PDSN and PCF. The PCF decapsulates the link/network layer frames in GRE frames before forwarding them on the IP connection between the PCF and the BS. The BS accepts these GRE frames, strips the GRE headers, and processes the link/layer frames as normal incoming frames by passing them to the upper layer. The other direction behaves analogously: The BS encapsulates

1 the link layer/network layer frames in GRE frames and sends them on the IP connection  
 2 between the BS and the PCF, the PCF decapsulates the link/network layer frames  
 3 received from the IP connection and re-encapsulates the link/network layer frames in  
 4 GRE frames before forwarding them on the IP connection between the PCF and the  
 5 PDSN. The PDSN accepts the GRE frames, strips the GRE headers, and processes the  
 6 link/network frames as normal incoming frames by passing them to the upper layer.

7 GRE encapsulates user traffic as shown in Figure 2.6-1.

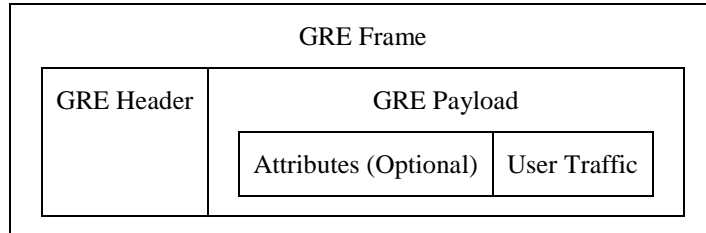

8 **Figure 2.6-1 GRE Encapsulated User Traffic**

9 Figure 2.6-2 shows the structure of the 3GPP2 GRE frame.

|                            |   |   |   |          |   |   |   |   |     |   |               |   |   |   |   |   |   |   |   |   |   |
|----------------------------|---|---|---|----------|---|---|---|---|-----|---|---------------|---|---|---|---|---|---|---|---|---|---|
| 0                          |   |   |   |          | 1 |   |   |   |     | 2 |               |   |   |   | 3 |   |   |   |   |   |   |
| 0                          | 1 | 2 | 3 | 4        | 5 | 6 | 7 | 8 | 9   | 0 | 1             | 2 | 3 | 4 | 5 | 6 | 7 | 8 | 9 | 0 | 1 |
| C                          | r | K | S | Reserved |   |   |   |   | Ver |   | Protocol Type |   |   |   |   |   |   |   |   |   |   |
| Key                        |   |   |   |          |   |   |   |   |     |   |               |   |   |   |   |   |   |   |   |   |   |
| Sequence number (Optional) |   |   |   |          |   |   |   |   |     |   |               |   |   |   |   |   |   |   |   |   |   |
| Attributes (Optional)      |   |   |   |          |   |   |   |   |     |   |               |   |   |   |   |   |   |   |   |   |   |
| User Traffic (Optional)    |   |   |   |          |   |   |   |   |     |   |               |   |   |   |   |   |   |   |   |   |   |

10 **Figure 2.6-2 3GPP2 GRE Frame**

11 The 3GPP2 GRE header shall be encoded as follows:

|    |                             |   |
|----|-----------------------------|---|
| 12 | C (Checksum Present)        | '0'   |
| 13 | r (reserved)                | '0'   |
| 14 | K (Key Present)             | '1'   |
| 15 | S (Sequence Number Present) | '0 or 1'  |
| 16 | Reserved                    | '00000000'  |
| 17 | Ver (Version Number)        | '000'   |
| 18 | Protocol Type               | Hex '88 81H' for "Unstructured Byte Stream", or hex<br>19 '88 D2H' for "3GPP2 Packet". The protocol type<br>20 shall be set to "3GPP2 Packet" only if the packet<br>21 contains attributes. Otherwise it shall be set to<br>22 "Unstructured Byte Stream". If the receiving entity<br>23 does not recognize the value of this field, it should<br>24 discard the GRE frame. |

1  
2  
3  
4  
5  
6  
7  
8  
9  
10  
11  
12  
13  
14  
15  
16  
17  
18  
19  
20  
21  
22  
23  
24  
25  
26  
27  
28  
29  
30

**Key** The Key field contains a four-octet number. The Key field is used for identifying an individual A8 or A10 connection.

**Sequence number** If the link layer/network layer protocol requires that the GRE packets be delivered in sequence (e.g. if a state-full compression mechanism is in use) over the connection, the S indicator shall be set to '1' and the sequence number field shall be included in each GRE packet sent over the connection. The sequence number field is used for in-order delivery of the encapsulated user data. For each GRE connection (identified by the Key field) and direction, the sending and receiving entities shall each maintain at most one Sequence Number counter independent of the Protocol Type field. When the sequence number field is included, the sender and receiver shall perform the following:

- The sequence numbers shall be set to zero after the connection is established.
- The sequence number shall be incremented according to [37] in each subsequent packet sent on the same connection
- Receipt of an out-of-sequence packet on a connection shall be handled according to [37].

**Attributes** If the Protocol Type field is set to '88 D2H' for "3GPP2 Packet", one or more attributes are included. Each attribute includes four or more octets and contains information specific to the attribute.

The Attribute format is as follows. The fields are transmitted from left to right.

| 0      | 1    | 2 | 3 | 4 | 5 | 6 | 7 | Octet |
|--------|------|---|---|---|---|---|---|-------|
| E      | Type |   |   |   |   |   |   | 1     |
| Length |      |   |   |   |   |   |   | 2     |
| Value  |      |   |   |   |   |   |   | 3     |
|        |      |   |   |   |   |   |   | n     |

**Figure 2.6-3 Attribute Format**

31  
32  
33  
34  
35  
36  
37  
38  
39  
40  
41  
42  
43  
44

**E:** The E bit is set to 1 for the last attribute in the attribute list. It is set to zero for all other attributes.

**Type:** The Type field identifies the type of attribute. If the receiving entity does not recognize the value of this field, it should discard the attribute, but process the remainder of the GRE frame.

**Length:** The Length field indicates the length in octets of the Value field.

**Value:** The Value field is two or more octets in length and contains information specific to the attribute. The format and length of the Value field are determined by the Type and Length fields. The Value field may contain one or more reserved bits. The sending entity

shall set the reserved bits to '0' and the receiving entity shall ignore the value of the reserved bits. If the receiving entity does not recognize the value of any non-reserved portion of this field, it should discard the attribute, but process the remainder of the GRE frame.

User Traffic

The User Traffic may follow the last attribute in the attribute list, indicated by the E bit set to 1.

## 2.6.1 GRE Attributes

This section contains the specification of attributes that may be included in a GRE frame when the Protocol Type field is set to '88 D2H' for "3GPP2 Packet".

### 2.6.1.1 Short Data Indicator

If the packet is tagged by the PDSN as being suitable for SDB transmission, it is identified by an attribute defined as follows:

| 0            | 1                 | 2 | 3 | 4 | 5 | 6 | 7 | Octet |
|--------------|-------------------|---|---|---|---|---|---|-------|
| E = [0,1]    | Type = '000 0001' |   |   |   |   |   |   | 1     |
| Length = 02H |                   |   |   |   |   |   |   | 2     |
| SDI = '1'    | Reserved          |   |   |   |   |   |   | 3     |
| Reserved     |                   |   |   |   |   |   |   | 4     |

Type '000 0001' – Short Data Indication  
 Length 02H  
 SDI 0 – Reserved  
 1 – packet suitable for SDB transmission

### 2.6.1.2 Flow Control Indication

If the PDSN has enabled flow control, the PCF may control the flow of packet data in the forward direction by including XON/XOFF signals in GRE frames sent to the PDSN, as follows:

| 0                              | 1                          | 2        | 3 | 4 | 5 | 6 | 7 | Octet |
|--------------------------------|----------------------------|----------|---|---|---|---|---|-------|
| E = [0,1]                      | Type = '000 0010'          |          |   |   |   |   |   | 1     |
| Length = 02H                   |                            |          |   |   |   |   |   | 2     |
| Flow Control Indicator = [0,1] | Duration Indicator = [0,1] | Reserved |   |   |   |   |   | 3     |
| Reserved                       |                            |          |   |   |   |   |   | 4     |

Type '000 0010' - Flow Control  
 Length 02H  
 Flow Control Indicator This field contains the flow control instructions from the PCF and is set in response to one or more events occurring within the RAN. It is used by the PDSN to determine when to stop and when to resume packet

|    |                    |  |
|----|--------------------|--|
| 1  |                    | transmission for a PDSI connection to the PCF. This    |
| 2  |                    | field is coded as follows:                             |
| 3  |                    | 1 – XOFF: PDSN shall stop sending data to the PCF      |
| 4  |                    | for the A10 connection identified by “key”, on         |
| 5  |                    | receiving this signal.                                 |
| 6  |                    | 0 – XON: If the PDSN has data available, it shall      |
| 7  |                    | resume data transmission to the PCF for the A10        |
| 8  |                    | connection identified by “key”, on receiving this      |
| 9  |                    | signal.  |
| 10 | Duration Indicator | This field is valid when the Flow Control Indicator    |
| 11 |                    | field is set to XOFF. The PCF sets this field based on |
| 12 |                    | the event in the RAN triggering flow control for the   |
| 13 |                    | PDSI connection, how long the XOFF condition is        |
| 14 |                    | expected to last, and other information. The PDSN      |
| 15 |                    | uses this field with other information to determine if |
| 16 |                    | the flow-controlled packets for the PDSI should be     |
| 17 |                    | buffered.  |
| 18 |                    | 0 - TEMPORARY: The XOFF condition for the              |
| 19 |                    | PDSI connection is expected to be temporary.           |
| 20 |                    | The PDSN may buffer packets for the flow               |
| 21 |                    | controlled PDSI connection.                            |
| 22 |                    | 1 – INDEFINITE: The XOFF condition for the PDSI        |
| 23 |                    | connection is indefinite. The PDSN may drop            |
| 24 |                    | packets for the flow controlled PDSI connection.       |

## 2.6.2 Relationship of GRE tunnel to Quality of Service

---

The user’s IP traffic associated with the packet data service is tunneled across the RAN using GRE/IP transport. The inner IP packet is the packet transmitted between the user (e.g. Mobile Station (MS)) and its correspondent node (e.g. Internet server). The outer IP packet transports (or tunnels) a portion of the inner packet between the RAN components (i.e. BS, PCF, PDSN). Thus, the inner and outer packets may have inner and outer DSCP values whose usage is described as follows.

If the RAN supports QoS on the A8/A9 and A10/A11 interfaces, the RAN shall have a local RAN transport network QoS policy which indicates which outer DSCP values can be used by the PDSN, PCF and BS for traffic. These DSCP values shall be made available to the PDSN (e.g. via OAM&P functions) to enable QoS for the RAN transport network.

When QoS is required for GRE tunnels across the A8/A10 transport network, the IOS shall implement Diffserv as described in section 2.4.4 to support intra-network QoS requirements. In addition, the BS, PCF and PDSN shall follow specific mapping rules as follows:

1. The PDSN shall mark packets in the GRE tunnel (outer DSCP value) according to the policy in use by the RAN transport network (refer to section 2.4.4) connecting the PDSN to the PCF. This policy is local and specifies the DSCP values for use on each GRE tunnel (i.e. service instance) instantiated on the PDSN.
2. The PCF and BS shall use the local QoS policy (refer to section 2.4.4) to set the outer DSCP value of the packets in the GRE tunnels (i.e. service instance). Since the PCF and BS are not required to inspect the encapsulated IP packets to derive the inner DSCP value, the PCF and BS may mark all GRE packets in the same service instance (SI) with the same DSCP value. The PCF and BS may also set the DSCP

- 1 value of all GRE packets associated with the same user to the same value if this is  
2 the local policy.
- 3 3. The BS may use the outer DSCP value for RAN QoS functions (e.g. RLP frame  
4 prioritization). However, the BS is not required to differentiate between packets in  
5 the same SI or between users.

### 6 **2.6.3 GRE Protocol Usage for VoIP SOs**

---

7 The VoIP SOs define their own format for the GRE payload and may make use of the  
8 GRE sequence number or may require the sequence number to be absent. Refer to the SO  
9 specification [18] for more details.

### 10 **2.7 Use of RTP**

---

11 Real-time Transport Protocol (RTP) provides an end-to-end network transport function  
12 suitable for applications transmitting real-time data, such as audio, video, or simulation  
13 data, over multicast or unicast network services [39]. The complete specification of RTP  
14 also includes profile specifications (e.g. RTP/AVP) and payload type definitions [40].

### 15 **2.8 Use of SUA**

---

16 The Signaling Connection Control Part User Adaptation Layer (SUA) [42] defines a  
17 protocol for the transport of SS7 SCCP user-protocols, such as BSAP, over IP using  
18 SCTP.

### 19 **2.9 Base Station Application Part**

---

20 The Base Station Application Part (BSAP) is the application layer signaling protocol that  
21 provides messaging to accomplish the functions of the A1 or A1p interface component of  
22 the MSC - BS interface. BSAP is split into two sub-application parts; the BS  
23 Management Application Part (BSMAP), and the Direct Transfer Application Part  
24 (DTAP).

25 A distribution function located in the BSAP, which is reflected in the protocol  
26 specification by the layer 3 (A1 or A1p) header, performs the discrimination between  
27 BSMAP and DTAP messages. Refer to [14] for more information.

28 Refer to Figure 2.9-1 for an illustration of this structure.

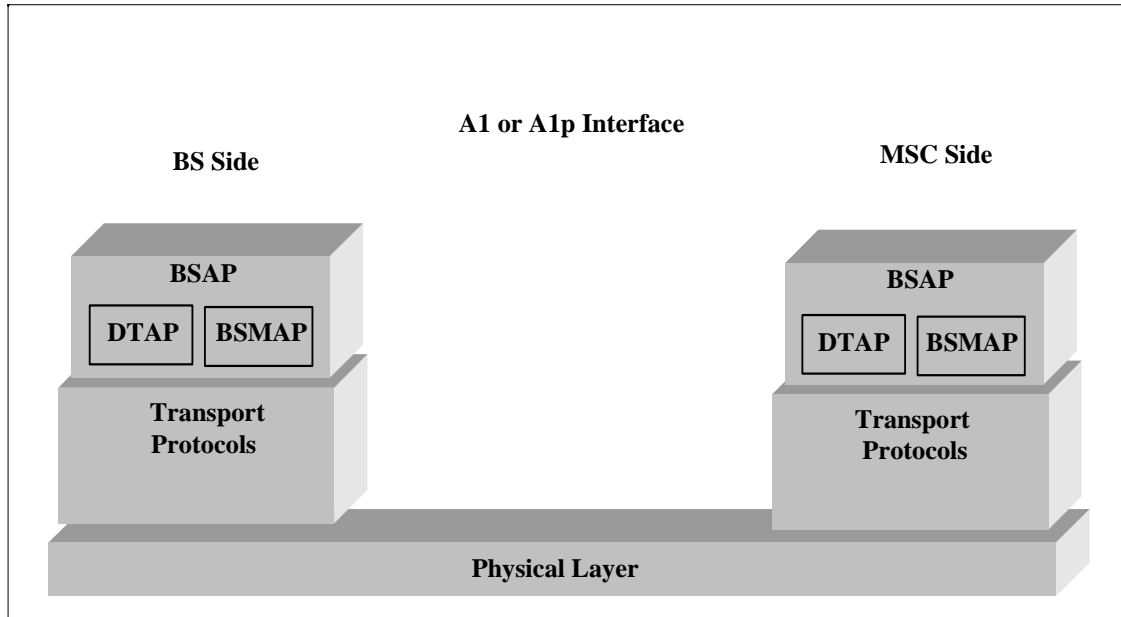

1  
2 **Figure 2.9-1 A1 or A1p Interface Signaling Protocol Reference Model**

3 **2.9.1 The BS Management Application Part**

---

4 The BSMAP supports all Radio Resource Management and Facility Management  
5 procedures between the MSC and the BS or a cell(s) within the BS. BSMAP messages  
6 are not passed to the MS, but are used only to perform functions at the MSC or the BS. A  
7 BSMAP message (Complete Layer 3 Information) is also used together with a DTAP  
8 message to establish a connection for an MS between the BS and the MSC, in response to  
9 the first layer 3 air interface message sent by the MS to the BS for each MS system  
10 request. The description of the layer 3 protocol for the BSMAP information exchange is  
11 contained in [14].

12 **2.9.2 The Direct Transfer Application Part**

---

13 The DTAP messages are used to transfer call processing and mobility management  
14 messages between the MSC and BS. DTAP messages carry call processing and mobility  
15 management information that is primarily used by the MS. The BS shall map the DTAP  
16 messages going to the MSC from the appropriate air interface signaling protocol.

17 **2.10 Use of SCTP**

---

18 SCTP provides a reliable message transport in IP networks. SCTP is used without any  
19 modifications and is defined in [38].

20 An SCTP connection between two endpoints is called an association. One SCTP  
21 association can be considered as a logical aggregation of streams. A stream is a  
22 unidirectional logical channel between two endpoints. To achieve bi-directional  
23 communications, two streams are necessary, one in each direction. Each user message  
24 (i.e., a message originated from the user application above SCTP) handled by SCTP has  
25 to specify the stream to which it is attached. A stream identifier exists for each stream  
26 within an association. Therefore, each SCTP stream can be considered as an independent

1 flow of user messages from one node to another. This stream independence characteristic  
2 provides a mechanism to avoid and/or manage blocking between streams.

## 3.0 Interface Specific Protocol Requirements

---

This section provides specific requirements for various protocol layers used in the IOS interfaces.

### 3.1 A1, A2, and A5 Interfaces

---

This section applies only to circuit-switched MSCs. All references to “MSC” in this section are references to circuit-switched MSCs.

The MSC-BS interface consists of user traffic channels and signaling channels. In general, user traffic channels are independent of signaling channels. Different paths and different underlying transport technologies can be employed for each.

The A1 interface shall use one of the channelized physical layer protocols T1 or E1 interface from section 2.1. The T1 and E1 may be mapped into one of the higher digital hierarchy protocols (e.g., T3, OC3, or STM1) specified in section 2.1. The A1 signaling interface is used to establish A2 and A5 user traffic circuit connections.

As a BS/MSC agreed option, Dedicated Signal Level 0 (DS0) signaling link(s) may be used instead of the T1/E1 interface.

The A2 and A5 interface shall use one of the channelized physical layer protocols T1 or E1 interface from section 2.1. The T1 and E1 may be mapped into one of the higher digital hierarchy protocols (e.g., T3, OC3, or STM1) specified in section 2.1.

This standard assumes the use of Signaling System Number 7 (SS7) signaling for the transport protocol on the A1 interface.

#### 3.1.1 Signaling Connection Transport Protocol Options

---

Signaling over the A1 interfaces requires a reliable transport protocol and appropriate addressing and routing mechanisms to deliver messages from source to destination. The IOS application is independent of the underlying transport, which is left to the discretion of operators and manufacturers. The signaling protocol stack options available to operators and manufacturers for the A1 interface is shown in Figure 3.1.1-1.

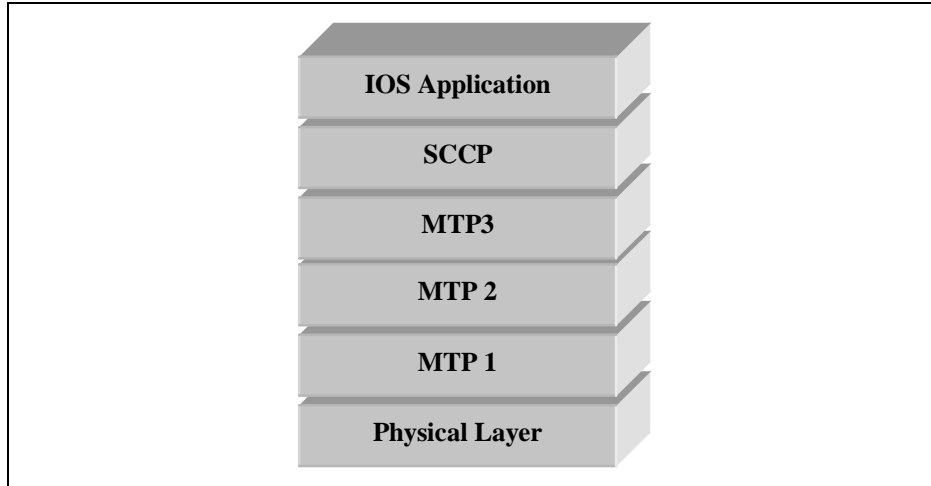

1  
2

**Figure 3.1.1-1 A1 Signaling Protocol Stack**

**3.1.2 User Traffic Connection Transport Protocol Options**

---

3  
4  
5  
6

The protocol stack options for transport of user traffic that are available to operators and manufacturers are shown in Figure 3.1.2-1 and Figure 3.1.2-2. The link layer for the A5 interface uses the Intersystem Link Protocol (ISLP) [19].

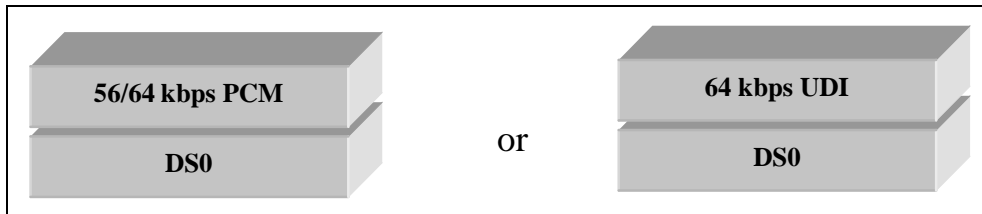

7  
8

**Figure 3.1.2-1 A2 User Traffic Protocol Stacks**

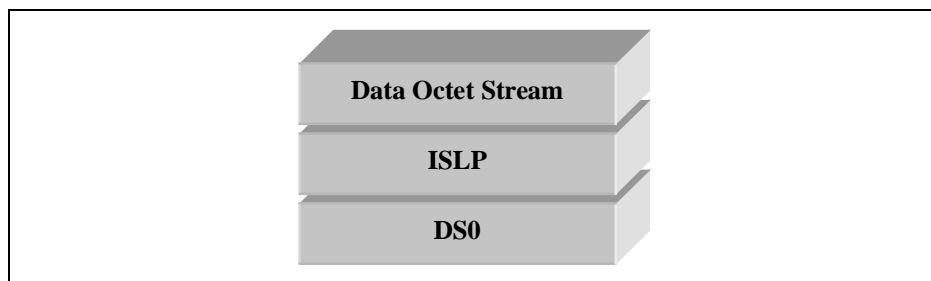

9  
10

**Figure 3.1.2-2 A5 User Traffic Protocol Stacks**

**3.1.3 Use of ANSI SS7 Transport (Layer 2)**

---

11  
12  
13

This standard specifies multiple protocols for the transport of signaling and user information. Refer to sections 3.1.1 and 3.1.2.

1 When SS7 is used to provide signaling transport, the underlying transport mechanism  
 2 defined to carry signaling information between the BS and the MSC is the Message  
 3 Transfer Part (MTP) and the Signaling Connection Control Part (SCCP).

4 The MTP and SCCP are used to transport the application layer signaling protocol, which  
 5 is defined as the BSAP.

6 Information for this section was excerpted from [21] and [22]. Section 3.1.3.2 deals with  
 7 the MTP. Section 3.1.3.3 deals with SCCP and its use.

8 The MTP provides a mechanism giving reliable transfer of signaling messages. Section  
 9 3.1.3.2 deals with the subset of the MTP that can be used between a BS and a MSC,  
 10 which is compatible with a full MTP.

11 SCCP is used to provide a referencing mechanism to identify a particular transaction  
 12 relating to, for instance, a particular call. Section 3.1.3.3 identifies the SCCP subset that  
 13 shall be used between a BS and an MSC. SCCP can also be used to enhance the message  
 14 routing for operations and maintenance information.

### 15 3.1.3.1 Field of Application

---

16 This section is applicable to the signaling between BSs and MSCs in Public Land Mobile  
 17 Networks (PLMNs). It provides a minimum set of MTP requirements that may be  
 18 implemented at a BS or MSC, while maintaining compatibility with the implementation  
 19 of a full specification of the MTP.

20 This section defines the interfaces at the 56 or 64 kbps boundary to the BS or MSC and  
 21 applies primarily to digital access arrangements. The use of analog arrangements is not  
 22 supported.

23 The reliability of signaling links is an administrative concern. It is recommended that in  
 24 the case where more than one multiplex system is required and reliability reasons dictate  
 25 the use of multiple link sets, then each signaling link should be assigned in a different  
 26 multiplex system.

27 Only the associated mode of signaling is applicable to the BS.

### 28 3.1.3.2 Message Transfer Part

---

29 The American National Standards Institute (ANSI) recommendations concerning MTP  
 30 shall be taken as being requirements unless covered by a statement in this section.

#### 31 3.1.3.2.1 General

---

32 The MTP functions as specified in [21] are applicable. However, the following  
 33 exceptions and modifications to those recommendations may be applied for the MSC to  
 34 BS signaling. Refer to section 3.1.3.2.2 through section 3.1.3.2.4.

#### 35 3.1.3.2.2 Level 1 (Chapter 2 of [21])

---

##### 36 **Chapter 2, Figure 2**

37 These figures are for information only. For the A1 interface, interface point C is  
 38 appropriate.

1                   **Chapter 2, Section 1.4 Analog Signaling Link**

2                   The use of analog signaling links is not an available option.

3                   **Chapter 2, Section 2 General**

4                   A signaling rate of 56/64 kbps is normally used. When higher speeds are needed, 1.536  
5                   Mbps digital paths can be used for the signaling data link.

6                   **Chapter 2, Section 3 Error Characteristics and Availability**

7                   Error characteristics and availability are an operator concern. Excessive errors could lead  
8                   to inefficient use of the signaling links.

9                   **Chapter 2, Section 5 Digital Signaling Link**

10                  The standard arrangement is to derive the signaling link from a T1/E1 digital path.  
11                  However, dedicated DS0 signaling link(s) may be used as a BS/MSC agreed option.

12                  **Chapter 2, Section 6 Analog Signaling Data Link**

13                  Only digital signaling data links are supported.

14   3.1.3.2.3      Level 2 (Chapter 3 of [21])

---

15                  **Chapter 3, Section 1.4 Signal Unit Error Correction**

16                  Only the basic error correction protocol is required.

17                  **Chapter 3, Section 7 Signaling Link Initial Alignment Procedure**

18                  In the initial alignment procedure specified in Chapter 3 of [21], only the emergency  
19                  proving period is applicable for the BS. Thus, in states 02 and 03 of the initial alignment  
20                  procedure status indication "N" is not sent from the BS. The BS should be capable of  
21                  recognizing status indication "N" if received in order for the alignment procedure to  
22                  complete.

23   3.1.3.2.4      Level 3 (Chapter 4 of [21])

---

24                  **Chapter 4, Section 1.1.2 End Point of a Signaling Link**

25                  The BS is only implemented as the end point of a signaling link. There are no Signaling  
26                  Transfer Point (STP) network management features in the BS.

1  
2  
3  
4  
5  
6  
7  
8  
9  
10  
11  
12  
13  
14  
15  
16  
17  
18  
19  
20  
21  
22  
23  
24  
25  
26  
27  
28  
29  
30  
31  
32  
33  
34  
35  
36  
37  
38

## **Chapter 4, Section 2**

Since STP functions are not required for discrimination and routing, MTP functions used between the MSC and the BS can be simplified. Since the implementation of this interface is intended only for point-to-point applications, the routing function within MTP is preset to select the point code appropriate to the parent MSC.

### **Chapter 4, Section 2.2 Routing Label**

Load sharing is performed on the BS with more than one signaling link by means of the Signaling Link Selection field.

### **Chapter 4, Section 2.3 Message Routing Function**

Load sharing between link sets is not required since there can only be one link set between the BS and MSC.

#### **Chapter 4, Section 2.3.5 Handling of Messages under Signaling Link Congestion**

The procedures for handling message congestion priority levels as defined for U. S. Signaling Networks in Chapter 4, section 2.3.5.2 of [21] shall be followed. The message priorities given in Appendix B (of Chapter 5 of [21]) for SCCP and MTP messages shall be used. The remaining message priorities for BSMAP and DTAP messages are provided in [14].

### **Chapter 4, Section 2.4 Message Discrimination**

At the BS, only messages with a correct Destination Point Code (DPC) are accepted. Other messages are discarded. It is recommended that discarding a message because of an incorrectly set point code should cause an incident report to be generated.

At an MSC (which has the capability of acting as an STP), administration procedures may determine that each message received from a BS signaling link is passed through a “screening” function that checks that the DPC of the message is the same as the Signaling Point code of the exchange. If that is the case, the message is sent to the normal MTP message handling functions. Otherwise, the message is discarded and an incident report is made.

### **Chapter 4, Section 3 Signaling Network Management**

Since the A1 interface utilizes point to point signaling between the BS and the MSC, the Signaling Route Management procedures, including the status of signaling routes, signaling route restricted, signaling route unavailability and availability, are not required.

#### **Chapter 4, Section 3.8 Signaling Network Congestion**

The procedures defined for U. S. Networks shall be followed for handling congestion on signaling links.

### **Chapter 4, Section 4 Signaling Traffic Management**

Since the A1 interface utilizes point to point signaling, the Traffic Management procedures supporting signaling routes, including signaling route restricted, signaling route unavailability and availability, are not required.

1                   **Chapter 4, Section 4.2**

2                   The normal routing situation is that there are one or more signaling links available  
3                   between the BS and MSC, and these links constitute a link set. They are run in load  
4                   sharing mode and changeover and change back procedures are supported between these  
5                   signaling links.

6                   **Chapter 4, Section 4.3.3**

7                   There is no alternative link set.

8                   **Chapter 4, Section 5 Changeover**

9                   Changeover between link sets is not applicable.

10                  **Chapter 4, Section 6 Change back**

11                 Change back between link sets is not applicable.

12                  **Chapter 4, Section 7 Forced Rerouting**

13                 Forced rerouting is not applicable since there is only one signaling route existing between  
14                 the BS and the MSC.

15                  **Chapter 4, Section 8 Controlled Rerouting**

16                 Controlled rerouting is not applicable since there is only one signaling route existing  
17                 between the BS and the MSC.

18                  **Chapter 4, Section 9 MTP Restart**

19                 The MTP Restart procedure is not required.

20                  **Chapter 4, Section 11 Signaling Traffic Flow Control**

21                 The Signaling Route Management procedures supporting signaling traffic flow control  
22                 including signaling route unavailability and signaling route set congestion are not  
23                 applicable for the A1 interface.

24                  **Chapter 4, Section 12 Signaling Link Management**

25                 Only basic link management procedures are applicable.

26                  **Chapter 4, Section 13 Signaling Link Management**

27                 Signaling Route Management procedure is not applicable for the A1 interface since it is a  
28                 point to point connection. No action is required upon reception of a Transfer-Prohibited  
29                 Signal, Transfer-Restricted Signal, Transfer-Allowed Signal, Signaling Route Set Test,  
30                 Signaling Route Set Congestion Test, or Transfer Control message.

31                  **Chapter 4, Section 14.2.1**

32                 Since all messages are passed using the SCCP, the service indicator is: D=0, C=0, B=1,  
33                 A=1.

1                   **Chapter 4, Section 14.2.2**

2                   The sub service field is always set to D=1, C=0, to indicate a national network.

3                   **Chapter 4, Section 15**

4                   The formats and codes listed are only relevant to the messages that are required.

5    3.1.3.2.5       Testing and Maintenance (Chapter 7 of [21])

---

6                   **Chapter 7, Section 2.1 Signaling Data Link Test**

7                   The Signaling Data Link Test procedure is not required for the A1 interface.

8                   **Chapter 7, Section 2.2**

9                   The generation of a Signaling Link Test Message (SLTM) is not applicable at the BS;  
10                  however the BS shall be capable of responding with an acknowledgment message to an  
11                  SLTM.

12   3.1.3.2.6       Interface Functions

---

13                  The method of interfacing to the higher layers is by the primitives defined in Chapter 1 of  
14                  [21].

15                  The primitives defined are:

- 16                  • MTP Pause indication
- 17                  • MTP Resume indication
- 18                  • MTP Status indication
- 19                  • MTP Transfer request
- 20                  • MTP Transfer indication

21   3.1.3.2.7       Overload Control (Message Throughput Congestion)

---

22                  MTP overload control is not required.

23   3.1.3.3         SCCP Transport Layer Specification (SCCP Functions)

---

24

25   3.1.3.3.1       Overview

---

26                  The purpose of this section is to identify the subset of the SCCP functions that are  
27                  necessary to achieve the management of the MS transactions in the A1 interface, and to  
28                  provide addressing facilities. If this subset of SCCP functions is implemented,  
29                  compatibility with a full ANSI SCCP shall be maintained. Only the needs of the BSAP  
30                  are taken into account in this section.

31                  The following simplifications are applicable to the signaling between BS and MSC in  
32                  PLMNs:

- 1                   • To limit the complexity of the procedures, a BS exchanges signaling messages only  
 2                   with its MSC, where a protocol conversion may be needed in some cases. Therefore,  
 3                   no SCCP translation function is required in the MSC between the national and the  
 4                   local SCCP and MTP within the MSC area.
- 5                   • Several functions of the SCCP are not used on the A1 interface: error detection,  
 6                   receipt confirmation, and flow control.
- 7                   • The segmenting/reassembling function shall be used if the total message length  
 8                   exceeds the maximum allowed message length that can be carried by the MTP.
- 9                   • Chapters 1 through 4 of [22] are considered as the basis for elaboration of this  
 10                  document.

### 11 3.1.3.3.2 Primitives (Chapter 1 of [22])

---

#### 12 **Chapter 1, Table 1**

13 Two primitives of the table are not used:

14 N-INFORM DATA

15 N-RESET

#### 16 **Chapter 1, Table 2**

17 The following parameters of the N-CONNECT primitive are not used:

18 Responding address

19 Receipt confirmation selection

20 Expedited data selection

#### 21 **Chapter 1, Table 3**

22 The following parameter of the N-DATA primitive is not used:

23 Confirmation request

#### 24 **Chapter 1, Table 6**

25 The following parameter of the N-DISCONNECT primitive is not used:

26 Responding address

#### 27 **Chapter 1, Section 2.1.2**

28 Permanent signaling connections are not applicable.

#### 29 **Chapter 1, Table 8**

30 The primitive N-NOTICE is not used.

#### 31 **Chapter 1, Table 8A**

32 The following parameter of the N-UNITDATA primitive is not used:

33 Return option

1                   **Chapter 1, Section 4.1.2**

2                   Functions for permanent signaling connections are not applicable.

3    3.1.3.3.3       **SCCP Messages (Chapter 2 of [22])**

---

4                   **Chapter 2, Section 2.4**

5                   The Data Acknowledgment message is not used.

6                   **Chapter 2, Section 2.6**

7                   The Data Form 2 (DT2) message is not used.

8                   **Chapter 2, Section 2.7**

9                   The Expedited Data message is not used.

10                  **Chapter 2, Section 2.8**

11                  The Expedited Data Acknowledgment message is not used.

12                  **Chapter 2, Section 2.10**

13                  The Protocol Data Unit Error message is not used; the inconsistent messages of the SCCP  
14                  protocol are discarded.

15                  **Chapter 2, Section 2.13**

16                  The Reset Confirm message is not used.

17                  **Chapter 2, Section 2.14**

18                  The Reset Request message is not used.

19                  **Chapter 2, Section 3.5**

20                  The Subsystem-Out-Of-Service-Grant (SOG) message is not used.

21                  **Chapter 2, Section 3.4**

22                  The Subsystem-Out-Of-Service (SOR) message is not used.

23                  **Chapter 2, Section 2.16**

24                  The Unit Data Service message is not used.

25                  **Chapter 2, Section 4.2**

26                  The “credit” parameter field is not used for protocol class 2. However, the parameter  
27                  shall still be included in the Inactivity Test (IT) message for syntax reasons.

1                   **Chapter 2, Section 4.6**

2                   The “error cause” parameter field is not used.

3                   **Chapter 2, Section 4.10**

4                   The “receive sequence number” parameter is not used.

5                   **Chapter 2, Section 4.13**

6                   The “reset cause” parameter field is not used.

7                   **Chapter 2, Section 4.16**

8                   The “sequencing/segmenting” parameter field is not used for protocol class 2. However,  
9                   the parameter shall still be included in the IT message for syntax reasons.

10                  **3.1.3.3.4           SCCP Formats and Codes (Chapter 3 of [22])**

---

11                   **Chapter 3, Section 3.4**

12                   For point-to-point network structures (i.e., direct connections between the MSC and BS),  
13                   the called party address may consist of the single element: subsystem number.

14                   No global title is used. The signaling point code which is coded in the MTP routing label  
15                   and the Subsystem Number (SSN) in the called party address allow the routing of the  
16                   message.

17                   **Chapter 3, Section 3.4.2.2**

18                   SSN Values: BSAP = 11111100, (252)

19                   Use of alternative values is an administrative concern.

20                   Note: It was determined that the IOS A1 interface should use its own SSN value and this  
21                   was selected as BSAP = 11111100 (252).

22                   **Chapter 3, Section 3.4.2.3**

23                   Global title: refer to Chapter 3, section 3.4 of [22].

24                   **Chapter 3, Section 3.6**

25                   Protocol classes 1 and 3 are not used.

26                   **Chapter 3, Sections 3.8, 3.9, 3.10, 3.13, 3.14**

27                   Parameters are not used.

28                   **Chapter 3, Sections 4.8, 4.9, 4.11, 4.12, 4.13, 4.14, 4.15, 4.16**

29                   Messages are not used.

|    |  |
|----|--|
| 1  | <b>Chapter 3, Section 5.1.1</b>  |
| 2  | SOR and SOG are not needed.  |
| 3  | <b>3.1.3.3.5</b> <b>SCCP Procedures (Chapter 4 of [22])</b>  |
| 4  | <hr/>  |
| 5  | <b>Chapter 4, Sections 1.1.2.2, 1.1.2.4</b>  |
| 6  | Protocol classes 1 and 3 are not used.   |
| 7  | <b>Chapter 4, Section 1.1.3</b>  |
| 8  | A signaling connection consists of a single connection section. No intermediate nodes are defined in the A1 interface.       |
| 9  | The use of multiple connections sections is an administrative concern.   |
| 10 | <b>Chapter 4, Section 1.2.1 (b)</b>  |
| 11 | Not applicable for single connections.   |
| 12 | <b>Chapter 4, Section 2.1 (1.)</b>   |
| 13 | Global title is not used for single connections.   |
| 14 | <b>Chapter 4, Section 2.2.1</b>  |
| 15 | SSN is only present in the called party address for single connections.  |
| 16 | <b>Chapter 4, Section 2.2.2</b>  |
| 17 | The addressing information may take the following form in the N-CONNECT request primitive: DPC+SSN (for single connections). |
| 18 |  |
| 19 | <b>Chapter 4, Section 2.2.2.2</b>  |
| 20 | No SCCP translation function is required for single connections.   |
| 21 | <b>Chapter 4, Section 2.3.1 (3)</b>  |
| 22 | Not applicable for single connections.   |
| 23 | <b>Chapter 4, Section 2.3.2 (4)</b>  |
| 24 | Not applicable for single connections.   |
| 25 | <b>Chapter 4, Section 3.1.3</b>  |
| 26 | Not applicable: no protocol class and flow control negotiations.   |
| 27 | <b>Chapter 4, Section 3.1.5</b>  |
| 28 | Not applicable.  |

1                   **Chapter 4, Section 3.2.2**

2                   Not applicable.

3                   **Chapter 4, Section 3.3.4**

4                   Not applicable.

5                   **Chapter 4, Section 3.5.1.2**

6                   Not applicable.

7                   **Chapter 4, Section 3.5.2**

8                   Not applicable.

9                   **Chapter 4, Sections 3.6, 3.7, 3.9, 3.10**

10                  Not applicable.

11                  **Chapter 4, Section 4.2**

12                  Message return is not applicable.

13                  **Chapter 4, Section 5**

14                  Only those messages and procedures relating to non-replicated subsystems or nodes are  
15                  required. At the BS the concerned point is the parent MSC. The subsystem involved is  
16                  the BSAP.

17    **3.1.3.4            Use of the SCCP**

---

18                  The SCCP is used to support signaling messages between the MSC and the BS. BSAP  
19                  (refer to section 2.9) uses one SCCP signaling connection for the transfer of layer 3 (A1)  
20                  messages per MS.

21                  The SCCP uses both connectionless (Class 0) and connection-oriented (Class 2)  
22                  procedures to support the BSAP. The procedures in this specification identify whether  
23                  connection-oriented or connectionless procedures are to be used for each layer 3 (A1)  
24                  procedure.

25    **3.1.3.4.1        Connection Establishment**

---

26                  The initial messages exchanged in call setup are used to establish an SCCP connection  
27                  for subsequent signaling communications relating to the call. A new connection is  
28                  established when individual information related to an MS transaction is required to be  
29                  exchanged between a BS and an MSC, and no such transaction exists between the MSC  
30                  and that BS.

31                  Two connection establishment cases are distinguished:

32                  Case 1.            A new transaction (e.g., Location updating, incoming or outgoing call –  
33                                       refer to [13]) is initiated on the radio path. Following an Access  
34                                       Request made by the MS on the Access Channel, the connection  
35                                       establishment is then initiated by the BS.

1 Case 2. The MSC decides to perform an inter-BS handoff (refer to [13]). The  
 2 connection establishment is then initiated by the MSC.

### 3 3.1.3.4.1.1 Establishment Procedure - Case 1

4 In this case, the connection establishment is initiated at the reception by the BS of the  
 5 first layer 3 message from the MS. Generally, such a message contains the Mobile  
 6 Identity parameter (Electronic Serial Number (ESN), or International Mobile Subscriber  
 7 Identity (IMSI)). The BS then constructs the first A1 interface BSMAP message  
 8 (Complete Layer 3 Information), which includes one of the appropriate DTAP messages  
 9 (Location Updating Request, Connection Management (CM) Service Request, or Paging  
 10 Response) depending on whether the MS is accessing the network for the purpose of  
 11 registration, call origination, or termination. The Complete Layer 3 Information message  
 12 is sent to the MSC in the user data field of the SCCP Connection Request message (refer  
 13 to [14]). The Complete Layer 3 Information message includes the cell identity and the  
 14 layer 3 message that was received from the MS. The exact coding of the BSMAP  
 15 message is specified in [14].

16 Upon receipt of the SCCP Connection Request message, the MSC may determine (for  
 17 example based on the type of DTAP message received, or based on the received identity,  
 18 whether another association already exists for the same MS) if it should proceed with  
 19 connection establishment or not. In the latter case the connection establishment is  
 20 refused. This message may optionally contain a BSMAP or DTAP message in the user  
 21 data field. Otherwise, an SCCP Connection Confirm message is sent back to the BS. This  
 22 message may optionally contain a BSMAP or DTAP message in the user data field.

23 The diagram in Figure 3.1.3.4.1.1-1 shows a successful SCCP connection establishment  
 24 procedure.

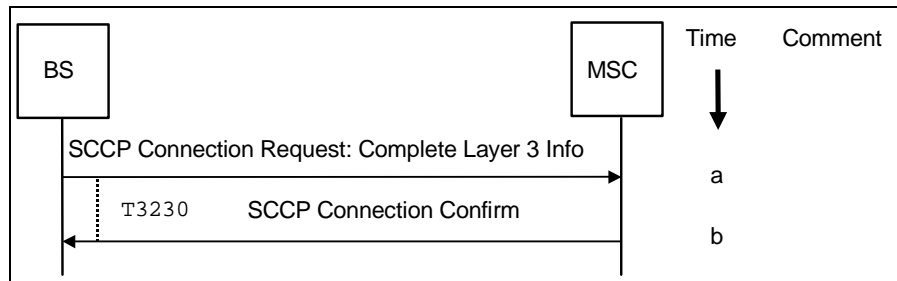

25

26 **Figure 3.1.3.4.1.1-1 SCCP Connection Establishment**

26

- 27 a. The BS sends an SCCP Connection Request message, including a user data field, to  
 28 the MSC. The BS starts timer  $T_{3230}$ . Refer to [14] for the  $T_{3230}$  timer definition.
- 29 b. Upon receipt of the SCCP Connection Request message, the MSC sends an SCCP  
 30 Connection Confirm message, which may contain a Layer 3 application message, to  
 31 the BS. Upon receipt of this message, the BS stops timer  $T_{3230}$  and establishes the  
 32 connection.

33 The procedures in case of connection establishment refusal are shown in Figure  
 34 3.1.3.4.1.1-2.

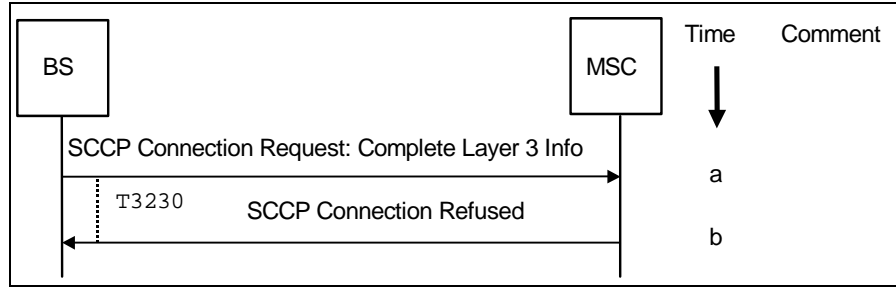

**Figure 3.1.3.4.1.1-2 SCCP Connection Establishment Refusal**

- a. The BS sends an SCCP Connection Request message, including a user data field, to the MSC. The BS then starts timer T<sub>3230</sub>.
- b. Upon receipt of the SCCP Connection Request message, the MSC sends an SCCP Connection Refused message to the BS. Upon receipt of this message, the BS stops timer T<sub>3230</sub>.

If the user data field of the SCCP Connection Request message contains a Complete Layer 3 Info message with a Location Updating Request application message, the MSC shall respond with an SCCP Connection Refused message with a Location Updating Accept, Location Updating Reject or Service Redirection message in the user data field.

#### 3.1.3.4.1.2 Establishment Procedure - Case 2

In this case, the connection establishment is initiated by the MSC as soon as the MSC decides to perform an inter-BS handoff.

An SCCP Connection Request message is sent to the BS. The user data field of this message may contain the BSMAP Handoff Request message (refer to [14]). If the layer 3 message is included, it shall be transferred in the user data field of the SCCP Connection Request to complete the establishment of the relation between the radio channel requested and the SCCP connection as soon as possible. The exact structure of the user data field is explained in [14]. If the BS received the SCCP Connection Request message without the Handoff Request message in the user data field, the BS establishes the SCCP connection by sending an SCCP Connection Confirm message. In this case, the Handoff Request and Handoff Request Ack messages are sent as DT1 messages after the SCCP connection is established.

When a BS receives an SCCP Connection Request message that contains a Handoff Request message in the user data field, the BS performs the necessary checking and reserves, in the successful case, a radio channel for the requested handoff. If the BS fails to reserve a radio channel, it may send an SCCP Connection Refuse message with a Handoff Failure message in the user data field to the MSC. Otherwise, an SCCP Connection Confirm message is returned to the MSC that may contain the BSMAP Handoff Request Acknowledge message in the user data field.

If the Handoff Request message is received as a DT1 message and the BS fails to reserve a radio channel for the call, then it shall send a Handoff Failure message as a DT1 message to the MSC.

The diagram in Figure 3.1.3.4.1.2-1 shows a successful SCCP connection establishment procedure during handoff.

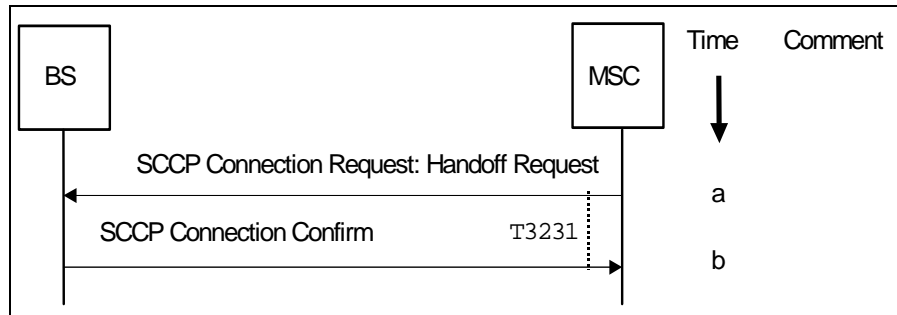

**Figure 3.1.3.4.1.2-1 SCCP Connection Establishment During Handoff**

- a. The MSC sends an SCCP Connection Request message, including a user data field that contains a Handoff Request application message, to the BS. The MSC starts timer  $T_{3231}$ . Refer to [14] for the  $T_{3231}$  timer definition.
- b. Upon receipt of the SCCP Connection Request message, the BS sends an SCCP Connection Confirm message, which shall contain the Layer 3 application message Handoff Request Acknowledge, to the MSC and establishes the connection. Upon receipt of this message, the MSC stops timer  $T_{3231}$ .

The diagram in Figure 3.1.3.4.1.2-2 shows an SCCP connection refusal during handoff.

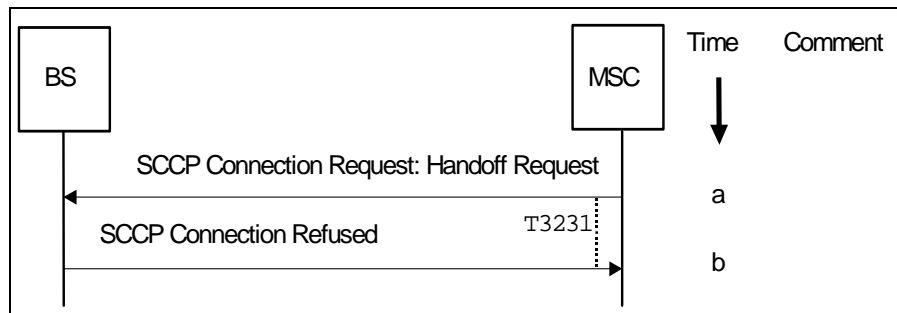

**Figure 3.1.3.4.1.2-2 SCCP Connection Refusal During Handoff**

- a. The MSC sends an SCCP Connection Request message, including a user data field that contains a Handoff Request application message, to the BS. The MSC starts timer  $T_{3231}$ .
- b. Upon receipt of the SCCP Connection Request message, the BS sends an SCCP Connection Refused message, which contains the Layer 3 application message Handoff Failure, to the MSC. Upon receipt of this message, the MSC stops timer  $T_{3231}$ .

### 3.1.3.4.2 Connection Release

This procedure is normally initiated at the MSC side but in the case of abnormal SCCP connection release (refer to 3.1.3.4.3), the BS may initiate connection clearing.

The MSC initiates this procedure with respect to the source BS in normal conditions for all calls supported by A1 connections.

1 A connection is released when a given signaling connection is no longer required. This  
 2 may occur in normal cases:

- 3 • at the end of a transaction (call, location updating);
- 4 • after completion of a successful hard handoff: the connection with the source BS is  
 5 released.

6 When either the MSC or the BS sends an SCCP Released (RLSD) message, the user data  
 7 field is optional and may contain a transparent layer 3 message (e.g., DTAP) or be empty.  
 8 The structure of the user data field, if any, is explained in [14].

9 When receiving this message, the BS releases or the MSC initiates release of all the radio  
 10 resources allocated to the relevant MS, if there are still any left, and returns an SCCP  
 11 Release Complete (RLC) message.

12 For abnormal cases a connection failure may be detected by the connection supervision  
 13 service provided by SCCP. If so, the Reset Circuit procedure described in [14] is used.  
 14 For other abnormal SCCP connection releases, refer to section 3.1.3.4.3, “Abnormal  
 15 SCCP Release”.

16 **3.1.3.4.3 Abnormal SCCP Release**

---

17 The normal release of SCCP A1 connections is initiated by the MSC. Under abnormal  
 18 conditions, an SCCP connection may be released by the BS to clear resources.

19 Whenever an SCCP connection is abnormally released, all resources associated with that  
 20 connection shall be cleared. Abnormal release can result from, for example, resource  
 21 failure, protocol error, or unexpected receipt of the SCCP RLSD or SCCP RLC  
 22 command.

23 **3.1.3.4.3.1 SCCP Release by BS: Loss of SCCP Connection Information**

---

24 Figure 3.1.3.4.3.1-1 demonstrates release of an SCCP connection by the BS due to loss of  
 25 SCCP connection information. Note that when a circuit(s) is associated with the call at  
 26 the MSC, Reset Circuit/Reset Circuit Ack [14] messages need to be exchanged between  
 27 the MSC and BS to guarantee release of the circuit by both the MSC and BS.

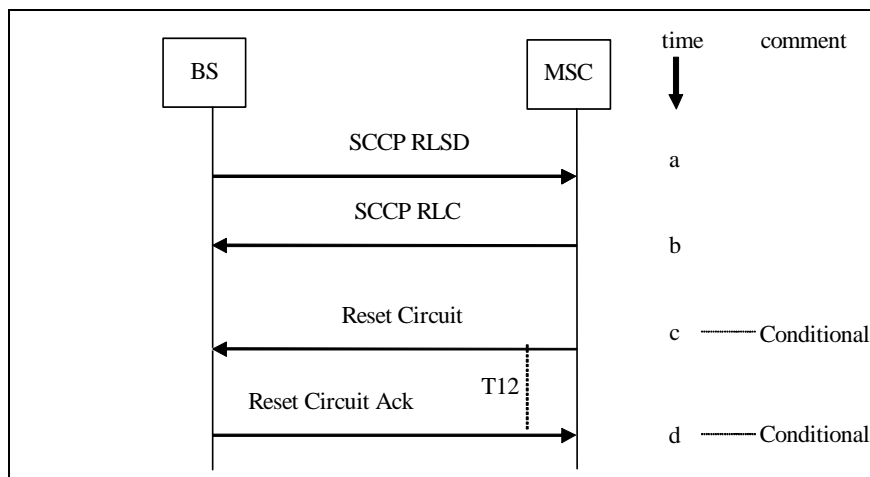

28 **Figure 3.1.3.4.3.1-1 BS Initiated SCCP Release: BS Lost SCCP Connection Information**

- 1 a. An unexpected SCCP RLSD message (under abnormal termination) is received by  
2 the MSC from the BS.
- 3 b. The MSC sends an SCCP RLC message to the BS to indicate that the SCCP RLSD  
4 message has been received and that the appropriate procedures have been completed.
- 5 c. If a circuit was involved with the call at the MSC, the MSC sends a Reset Circuit  
6 message to inform the BS that had sent the SCCP RLSD to clear its call data and  
7 starts timer  $T_{12}$ . Refer to [14] for the  $T_{12}$  timer definition. The Reset Circuit message  
8 carries the Circuit Identity Code (CIC) of the trunk whose corrupted connection was  
9 released.
- 10 d. The Reset Circuit Ack message informs the MSC that the Reset Circuit has been  
11 received and acted upon. The MSC stops timer  $T_{12}$ .

#### 12 3.1.3.4.3.2 SCCP Release by MSC: Loss of SCCP Connection Information

13 Figure 3.1.3.4.3.2-1 demonstrates release of an SCCP connection by the MSC due to loss  
14 of SCCP connection information. Note that when a circuit(s) is associated with the call at  
15 the BS, Reset Circuit/Reset Circuit Ack messages [14] need to be exchanged between the  
16 MSC and BS to guarantee release of the circuit by both the MSC and BS.

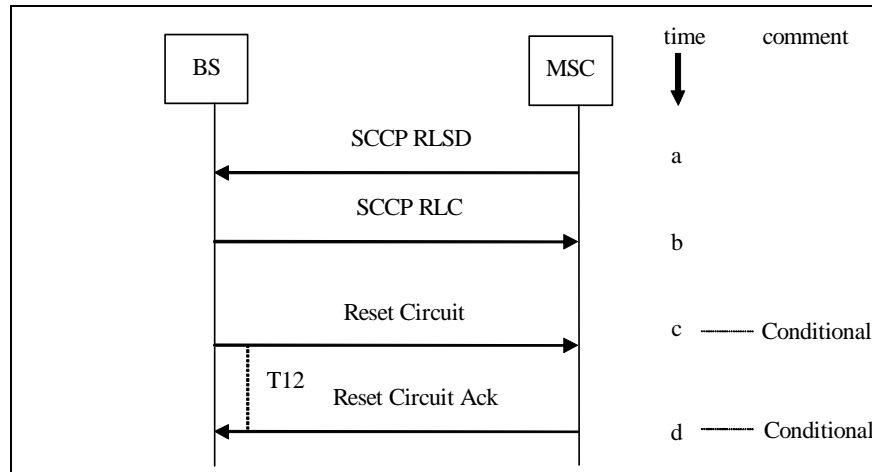

17

18 **Figure 3.1.3.4.3.2-1 MSC Initiated SCCP Release: MSC Lost SCCP Connection Information**

- 19 a. An unexpected SCCP RLSD message (under abnormal termination) is received by  
20 the BS from the MSC.
- 21 b. The BS sends an SCCP RLC message to the MSC to indicate that the SCCP RLSD  
22 message has been received and that the appropriate procedures have been completed.
- 23 c. If a circuit was involved with the call at the BS, the BS sends a Reset Circuit  
24 message to inform the MSC which had sent the SCCP RLSD to clear its call data and  
25 starts timer  $T_{12}$ . The Reset Circuit message carries the CIC of the trunk whose  
26 corrupted connection was released.
- 27 d. The Reset Circuit Ack message informs the BS that the Reset Circuit has been  
28 received and acted upon. The BS stops timer  $T_{12}$ .

#### 29 3.1.3.4.4 SCCP Reference Generation Philosophy

30 Referring to Figure 3.1.3.4.4-1 “SLR/DLR Usage”, the SCCP local reference number  
31 (source/destination) is a three byte element internally chosen by the MSC or BS to

1 uniquely identify a signaling connection. In the direction MSC to BS, the source local  
 2 reference is chosen by the MSC and the destination local reference is chosen by the BS.  
 3 In the direction BS to MSC, the source local reference is chosen by the BS and the  
 4 destination local reference is chosen by the MSC. In the direction MSC to BS, the MSC  
 5 always echoes the BS Source Local Reference (SLR) in the Destination Local Reference  
 6 (DLR) field. In the direction BS to MSC, the BS always echoes the MSC SLR in the  
 7 DLR field. Note that it is the responsibility of the BS and MSC to insure that no two calls  
 8 have identical SCCP local reference numbers.

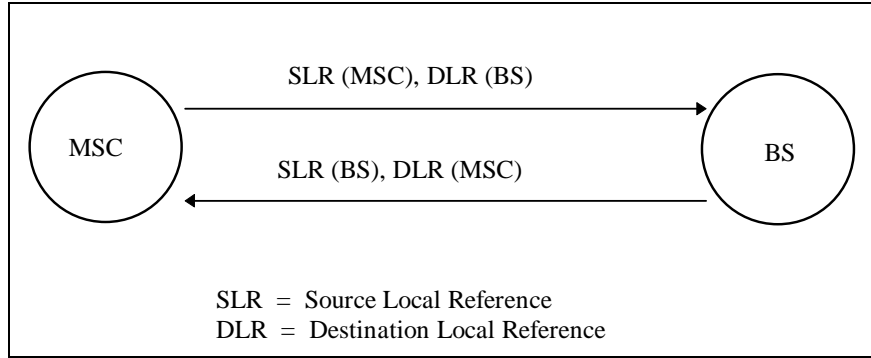

9  
10 **Figure 3.1.3.4.4-1 SLR/DLR Usage**

11 MSC generation of SCCP local reference numbers shall conform to [22].

12 **3.1.3.4.5 SCCP Transfer of DTAP and BSMAP Messages**

13 The DTAP and BSMAP messages on the A1 interface are contained in the user data field  
 14 of the exchanged SCCP frames. Table 3.1.3.4.5-1 below summarizes the use of the User  
 15 Data Field in SCCP frames.

16 **Table 3.1.3.4.5-1 Use of the User Data Field in SCCP Frames**

| SCCP Frame                                  | User Data Field (BSMAP/DTAP) |
|---|------------------------------|
| <b>Connection Oriented Protocol Class 2</b> |                              |
| SCCP Connection Request (CR)                | Optional                     |
| SCCP Connection Confirm (CC)                | Optional                     |
| SCCP Connection Refused (CREF)              | Optional                     |
| SCCP Released (RLSD)                        | Optional                     |
| SCCP Release Complete (RLC)                 | Not Applicable               |
| SCCP Data Transfer 1 (DT1)                  | Mandatory                    |
| <b>Connectionless Protocol Class 0</b>      |                              |
| SCCP Unit Data (UDT)                        | Mandatory                    |

17 For connection oriented transactions, a connection is requested, obtained or refused using  
 18 the following SCCP messages (protocol class 2):

- 19
- SCCP Connection Request (CR)
  - SCCP Connection Confirm (CC)
  - SCCP Connection Refused (CREF)
- 21

- SCCP Released (RLSD) and SCCP Release Complete (RLC) messages are used to break a connection.

The use of the User Data Field in SCCP frames in the various establishment and release cases is described in section 3.1.3.4.1, “Connection Establishment” and section 3.1.3.4.2, “Connection Release”.

For connection oriented (protocol class 2) transactions, once the signaling connection is confirmed between the MSC and the BS, all A1 interface messages are transported in the SCCP Data Transfer 1 (DT1) message until the connection is to be dropped.

For Connectionless (protocol class 0) transactions, where there is no SCCP connection, A1 interface messages are transported in the SCCP Unit Data (UDT) message.

Table 3.1.3.4.5-2 below indicates which SCCP messages shall be used to transport each of the application messages on the A1 interface.

**Table 3.1.3.4.5-2 Use of SCCP for BSMAP and DTAP Messages**

| <b>Application Message</b>             | <b>Message Discriminator</b> | <b>SCCP Message</b>   |
|--|------------------------------|-----------------------|
| <b>Call Processing Messages</b>        |                              |                       |
| Complete Layer 3 Information           | BSMAP                        | CR <sup>a</sup>       |
| CM Service Request                     | DTAP                         | CR <sup>a,b</sup>     |
| Paging Request                         | BSMAP                        | UDT <sup>a</sup>      |
| Paging Response                        | DTAP                         | CR <sup>a,b</sup>     |
| CM Service Request Continuation        | DTAP                         | DT1 <sup>c</sup>      |
| Connect                                | DTAP                         | DT1                   |
| Progress                               | DTAP                         | DT1                   |
| Service Release                        | DTAP                         | DT1                   |
| Service Release Complete               | DTAP                         | DT1                   |
| Assignment Request                     | BSMAP                        | CC <sup>d</sup> , DT1 |
| Assignment Complete                    | BSMAP                        | DT1                   |
| Assignment Failure                     | BSMAP                        | DT1                   |
| Clear Request                          | BSMAP                        | DT1                   |
| Clear Command                          | BSMAP                        | DT1                   |
| Clear Complete                         | BSMAP                        | DT1                   |
| Alert With Information                 | DTAP                         | DT1                   |
| BS Service Request                     | BSMAP                        | UDT                   |
| BS Service Response                    | BSMAP                        | UDT                   |
| Additional Service Request             | DTAP                         | DT1                   |
| Additional Service Notification        | BSMAP                        | DT1                   |
| <b>Supplementary Services Messages</b> |                              |                       |
| Flash with Information                 | DTAP                         | DT1                   |
| Flash with Information Ack             | DTAP                         | DT1                   |

**Table 3.1.3.4.5-2 Use of SCCP for BSMAP and DTAP Messages**

| <b>Application Message</b>                        | <b>Message Discriminator</b> | <b>SCCP Message</b>   |
|---|------------------------------|-----------------------|
| Feature Notification                              | BSMAP                        | UDT <sup>a</sup>      |
| Feature Notification Ack                          | BSMAP                        | UDT <sup>a</sup>      |
| Priority Access Channel Assignment (PACA) Command | BSMAP                        | CC <sup>d</sup> , DT1 |
| PACA Command Ack                                  | BSMAP                        | DT1                   |
| PACA Update                                       | BSMAP                        | UDT                   |
| PACA Update Ack                                   | BSMAP                        | UDT                   |
| Radio Measurements for Position Request           | BSMAP                        | DT1                   |
| Radio Measurements for Position Response          | BSMAP                        | DT1                   |
| <b>Mobility Management Messages</b>               |                              |                       |
| Authentication Request                            | DTAP/BSMAP                   | DT1, UDT <sup>c</sup> |
| Authentication Response                           | DTAP/BSMAP                   | DT1, UDT <sup>c</sup> |
| SSD Update Request                                | DTAP                         | DT1                   |
| Base Station Challenge                            | DTAP                         | DT1                   |
| Base Station Challenge Response                   | DTAP                         | DT1                   |
| Status Request                                    | DTAP/BSMAP                   | DT1, UDT <sup>c</sup> |
| Status Response                                   | DTAP/BSMAP                   | DT1, UDT <sup>c</sup> |
| SSD Update Response                               | DTAP                         | DT1                   |
| Location Updating Request                         | DTAP                         | CR <sup>a,b</sup>     |
| Location Updating Accept                          | DTAP                         | CREF                  |
| Location Updating Reject                          | DTAP                         | CREF                  |
| Mobile Station Registered Notification            | BSMAP                        | DT1                   |
| Parameter Update Request                          | DTAP                         | DT1                   |
| Parameter Update Confirm                          | DTAP                         | DT1                   |
| Privacy Mode Command                              | BSMAP                        | DT1                   |
| Privacy Mode Complete                             | BSMAP                        | DT1                   |
| Registration Request                              | BSMAP                        | UDT                   |
| User Zone Reject                                  | DTAP/BSMAP                   | DT1, UDT <sup>c</sup> |
| User Zone Update                                  | DTAP                         | DT1                   |
| User Zone Update Request                          | DTAP                         | DT1                   |
| BS Authentication Request                         | BSMAP                        | DT1                   |
| BS Authentication Response                        | BSMAP                        | DT1                   |
| <b>Handoff Messages</b>                           |                              |                       |
| Handoff Required                                  | BSMAP                        | DT1                   |
| Handoff Request                                   | BSMAP                        | CR, DT1 <sup>h</sup>  |

**Table 3.1.3.4.5-2 Use of SCCP for BSMAP and DTAP Messages**

| <b>Application Message</b>                               | <b>Message Discriminator</b> | <b>SCCP Message</b>                  |
|--|------------------------------|--------------------------------------|
| Handoff Request Acknowledge                              | BSMAP                        | CC, DT1 <sup>f</sup>                 |
| Handoff Failure  | BSMAP                        | DT1 <sup>f</sup> , CREF <sup>g</sup> |
| Handoff Command  | BSMAP                        | DT1                                  |
| Handoff Required Reject                                  | BSMAP                        | DT1                                  |
| Handoff Commenced  | BSMAP                        | DT1                                  |
| Handoff Complete   | BSMAP                        | DT1                                  |
| Handoff Performed  | BSMAP                        | DT1                                  |
| <b>Facilities Management Messages</b>                    |                              |                                      |
| Block  | BSMAP                        | UDT                                  |
| Block Acknowledge  | BSMAP                        | UDT                                  |
| Unblock  | BSMAP                        | UDT                                  |
| Unblock Acknowledge                                      | BSMAP                        | UDT                                  |
| Reset  | BSMAP                        | UDT                                  |
| Reset Acknowledge  | BSMAP                        | UDT                                  |
| Reset Circuit  | BSMAP                        | UDT                                  |
| Reset Circuit Acknowledge                                | BSMAP                        | UDT                                  |
| Service Redirection                                      | DTAP                         | DT1, CREF                            |
| Transcoder Control Request                               | BSMAP                        | DT1                                  |
| Transcoder Control Acknowledge                           | BSMAP                        | DT1                                  |
| <b>Application Data Delivery Service (ADDS) Messages</b> |                              |                                      |
| ADDS Page  | BSMAP                        | UDT                                  |
| ADDS Transfer  | BSMAP                        | UDT                                  |
| ADDS Deliver   | DTAP                         | DT1                                  |
| ADDS Page Ack  | BSMAP                        | UDT                                  |
| ADDS Deliver Ack   | DTAP                         | DT1                                  |
| ADDS Transfer Ack  | BSMAP                        | UDT                                  |
| <b>Error Handling Messages</b>                           |                              |                                      |
| Rejection  | DTAP/BSMAP                   | DT1, UDT <sup>e</sup>                |

- 1 Following are the footnotes referred to in Table 3.1.3.4.5-2.
- 2 a. Required, SCCP DT1 is not an option.
- 3 b. Sent within Complete Layer 3 Information, which is a BSMAP message.
- 4 c. This message may be used in addition to the CM Service Request.
- 5 d. May be used if responding to a CM Service Request or Paging Response.
- 6 e. Used only when the procedure is done on a paging channel.
- 7 f. May be used after an SCCP connection has been established.

- 1 g. May be used if responding to an SCCP Connection Request/Handoff Request.
- 2 h. This message is sent as DT1 if it is too large to fit into the User Data field of the
- 3 Connection Request.

4 **3.2 A1p and A2p Interfaces**

---

5 The A1p packet based signaling interface between the Legacy MS Domain (LMSD)  
 6 Mobile Switching Center Emulation (MSCe) and the BS is used in part to establish  
 7 packet based A2p user traffic connections between the Media Gateway (MGW) and the  
 8 BS. Message details for A1p and A2p are contained in [14].

9 **3.2.1 Performance Specifications**

---

10 The performance requirements for the A1p and A2p interface are for further study.

11 **3.2.2 A1p Transport Protocol**

---

12 Signaling over the A1p interfaces requires a reliable transport protocol and appropriate  
 13 addressing and routing mechanisms to deliver messages from source to destination. The  
 14 IOS application is independent of the underlying physical layer and link layer transport,  
 15 which is left to the discretion of operators and manufacturers. The signaling protocol  
 16 stack for the A1p interface is shown in Figure 3.2.2-1.

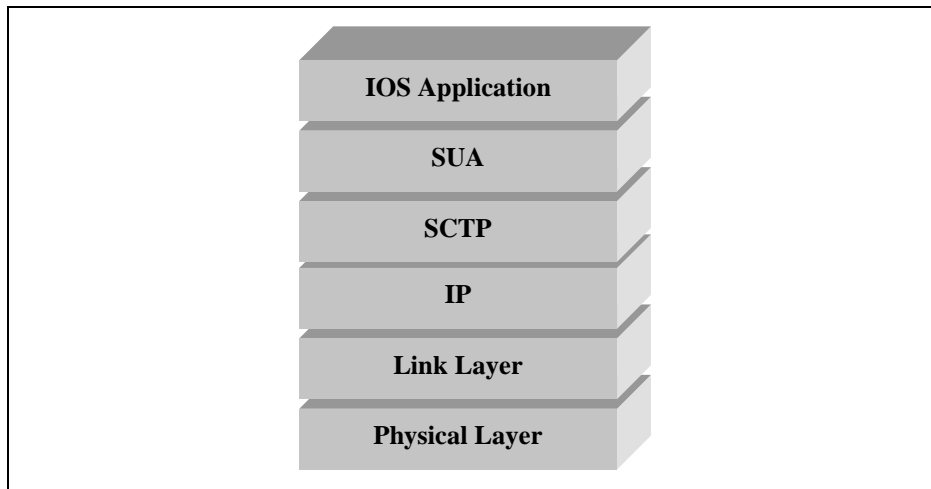

17  
 18 **Figure 3.2.2-1 A1p Signaling Protocol Stack**

19 **3.2.2.1 Physical Layer (L1) Specification for A1p**

---

20 The A1p interface shall use one of the L1 specifications in section 2.1.

21 **3.2.2.2 Layer 2 Specification for A1p**

---

22 The A1p L2 requirements as specified in section 2.2 may apply as per inter-vendor  
 23 agreements.

|    |                  |  |
|----|------------------|--|
| 1  | <b>3.2.2.3</b>   | <b>Use of IP for A1p</b>   |
| 2  |                  | The requirements for 2.4.1 and 2.4.2 may apply as per inter-vendor agreements.               |
| 3  | <b>3.2.2.4</b>   | <b>QoS Specifications for A1p</b>  |
| 4  |                  | The A1p QoS requirements are for further study.  |
| 5  | <b>3.2.2.5</b>   | <b>Security Specifications for A1p</b>   |
| 6  |                  | The A1p bearer Security Framework requirements are specified in section 2.4.5.               |
| 7  | <b>3.2.2.6</b>   | <b>Use of the SUA for A1p</b>  |
| 8  |                  | The SUA is used to support signaling messages between the MSCe and the BS. BSAP              |
| 9  |                  | (refer to section 3.2.2.7) uses one SUA signaling connection for the transfer of layer 3     |
| 10 |                  | (A1p) messages per MS.   |
| 11 |                  | The SUA uses both connectionless (Class 0) and connection-oriented (Class 2)                 |
| 12 |                  | procedures to support the BSAP. The procedures in this specification identify whether        |
| 13 |                  | connection-oriented or connectionless procedures are to be used for each layer 3 (A1p)       |
| 14 |                  | procedure.   |
| 15 |                  | The use of SUA in this standard is limited to the equivalent subset of functions that SCCP   |
| 16 |                  | is limited to in this standard.  |
| 17 |                  | The procedures and formats for the following SUA messages shall be supported by the          |
| 18 |                  | A1p interface (refer to [42]). Support for other SUA messages and procedures are for         |
| 19 |                  | further study.   |
| 20 |                  | Connectionless messages:   |
| 21 |                  | <ul style="list-style-type: none"> <li>• Connectionless Data Transfer (CLDT)</li> </ul>      |
| 22 |                  | Connection-Oriented messages:  |
| 23 |                  | <ul style="list-style-type: none"> <li>• Connection Request (CORE)</li> </ul>                |
| 24 |                  | <ul style="list-style-type: none"> <li>• Connection Acknowledge (COAK)</li> </ul>            |
| 25 |                  | <ul style="list-style-type: none"> <li>• Connection Refused (COREF)</li> </ul>               |
| 26 |                  | <ul style="list-style-type: none"> <li>• Connection Oriented Data Transfer (CODT)</li> </ul> |
| 27 |                  | <ul style="list-style-type: none"> <li>• Release Request (RELRE)</li> </ul>                  |
| 28 |                  | <ul style="list-style-type: none"> <li>• Release Complete (RELCO)</li> </ul>                 |
| 29 | <b>3.2.2.6.1</b> | <b>SUA Connection Establishment</b>  |
| 30 |                  | The initial messages exchanged in call setup are used to establish an SUA connection for     |
| 31 |                  | subsequent signaling communications relating to the call. A new connection is                |
| 32 |                  | established when individual information related to an MS transaction is required to be       |
| 33 |                  | exchanged between a BS and an MSCe, and no such transaction exists between the               |
| 34 |                  | MSCe and that BS.  |
| 35 |                  | Two connection establishment cases are distinguished:  |

- 1 Case 1. A new transaction (e.g., Location updating, incoming or outgoing call –
- 2 refer to [13]) is initiated on the radio path. Following an Access
- 3 Request made by the MS on the Access Channel, the connection
- 4 establishment is then initiated by the BS.
- 5 Case 2. The MSCe decides to perform an inter-BS handoff (refer to [13]). The
- 6 connection establishment is then initiated by the MSCe.

7 **3.2.2.6.1.1 Establishment Procedure - Case 1**

8 In this case, the connection establishment is initiated at the reception by the BS of the  
 9 first layer 3 message from the MS. Generally, such a message contains the Mobile  
 10 Identity parameter (Electronic Serial Number (ESN), or International Mobile Subscriber  
 11 Identity (IMSI)). The BS then constructs the first A1p interface BSMAP message  
 12 (Complete Layer 3 Information), which includes one of the appropriate DTAP messages  
 13 (Location Updating Request, Connection Management (CM) Service Request, or Paging  
 14 Response) depending on whether the MS is accessing the network for the purpose of  
 15 registration, call origination, or termination. The Complete Layer 3 Information message  
 16 is sent to the MSCe in the user data field of the SUA Connection Request (CORE)  
 17 message (refer to [42]). The Complete Layer 3 Information message includes the cell  
 18 identity and the layer 3 message that was received from the MS. The exact coding of the  
 19 BSMAP message is specified in [14].

20 Upon receipt of the SUA Connection Request message, the MSC may determine (for  
 21 example based on the type of DTAP message received, or based on the received identity,  
 22 whether another association already exists for the same MS) if it should proceed with  
 23 connection establishment or not. In the latter case the connection establishment is  
 24 refused. This message may optionally contain a BSMAP or DTAP message in the user  
 25 data field. Otherwise, an SUA Connection Acknowledge (COAK) message is sent back  
 26 to the BS. This message may optionally contain a BSMAP or DTAP message in the user  
 27 data field.

28 The diagram in Figure 3.2.2.6.1.1-1 shows a successful SUA connection establishment  
 29 procedure.

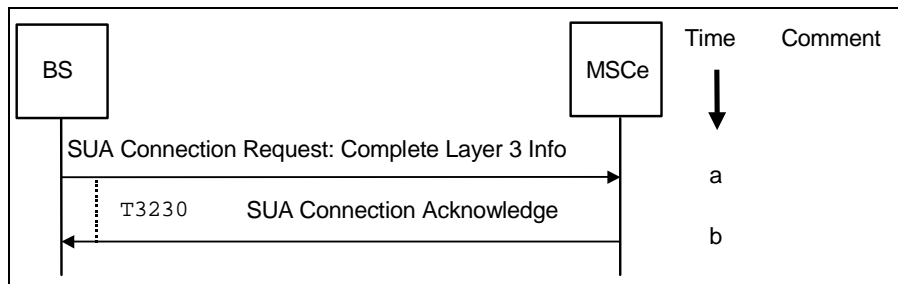

30 **Figure 3.2.2.6.1.1-1 SUA Connection Establishment**

- 31 a. The BS sends an SUA Connection Request message, including a user data field, to
- 32 the MSCe. The BS starts timer T<sub>3230</sub>. Refer to [14] for the T<sub>3230</sub> timer definition.
- 33 b. Upon receipt of the SUA Connection Request message, the MSCe sends an SUA
- 34 Connection Acknowledge message, which may contain a Layer 3 application
- 35 message, to the BS. Upon receipt of this message, the BS stops timer T<sub>3230</sub> and
- 36 establishes the connection.
- 37

38 The procedures in case of connection establishment refusal are shown in Figure 3.2.2.6.1-  
 39 2.

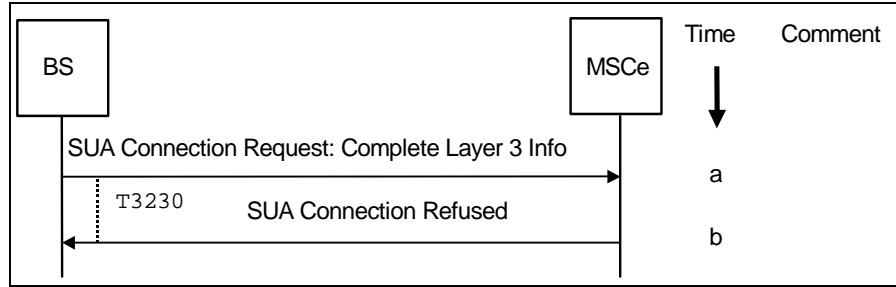

**Figure 3.2.2.6.1-2 SUA Connection Establishment Refusal**

- a. The BS sends an SUA Connection Request message, including a user data field, to the MSCe. The BS then starts timer T<sub>3230</sub>.
- b. Upon receipt of the SUA Connection Request message, the MSCe sends an SUA Connection Refused (COREF) message to the BS. Upon receipt of this message, the BS stops timer T<sub>3230</sub>.

If the user data field of the SUA Connection Request message contains a Complete Layer 3 Info message with a Location Updating Request application message, the MSCe shall respond with an SUA Connection Refused message with a Location Updating Accept, Location Updating Reject, Service Redirection message in the user data field.

#### 3.2.2.6.1.2 Establishment Procedure - Case 2

In this case, the connection establishment is initiated by the MSCe as soon as the MSCe decides to perform an inter-BS handoff.

An SUA Connection Request message is sent to the BS. The user data field of this message shall contain the BSMAP Handoff Request message (refer to [14]). It shall be transferred in the user data field of the SUA Connection Request message to complete the establishment of the relation between the radio channel requested and the SUA connection as soon as possible. The exact structure of the user data field is explained in [14].

When a BS receives an SUA Connection Request message that contains a Handoff Request message in the user data field, the BS performs the necessary checking and reserves, in the successful case, a radio channel for the requested handoff. If the BS fails to reserve a radio channel, it may send an SUA Connection Refused message with a Handoff Failure message in the user data field to the MSCe. Otherwise, an SUA Connection Acknowledge message is returned to the MSCe that may contain the BSMAP Handoff Request Acknowledge message in the user data field.

The diagram in Figure 3.2.2.6.1.2-1 shows a successful SUA connection establishment procedure during handoff.

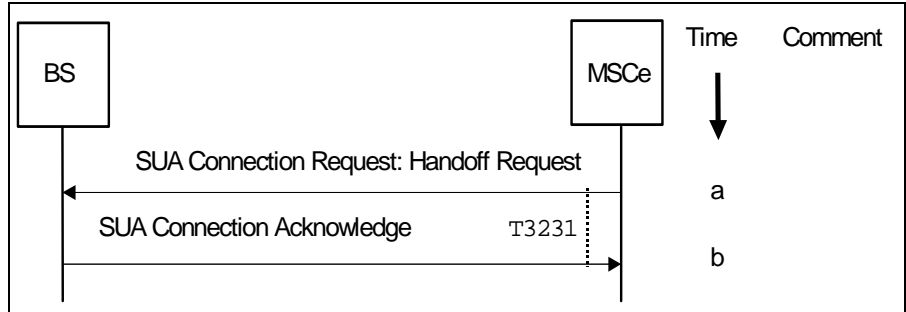

**Figure 3.2.2.6.1.2-1 SUA Connection Establishment During Handoff**

- a. The MSCe sends an SUA Connection Request message, including a user data field that contains a Handoff Request application message, to the BS. The MSCe starts timer T<sub>3231</sub>. Refer to [14] for the T<sub>3231</sub> timer definition.
- b. Upon receipt of the SUA Connection Request message, the BS sends an SUA Connection Acknowledge message, which shall contain the Layer 3 Handoff Request Acknowledge application message, to the MSCe and establishes the connection. Upon receipt of this message, the MSCe stops timer T<sub>3231</sub>.

The diagram in Figure 3.2.2.6.1.2-2 shows an SUA connection refusal during handoff.

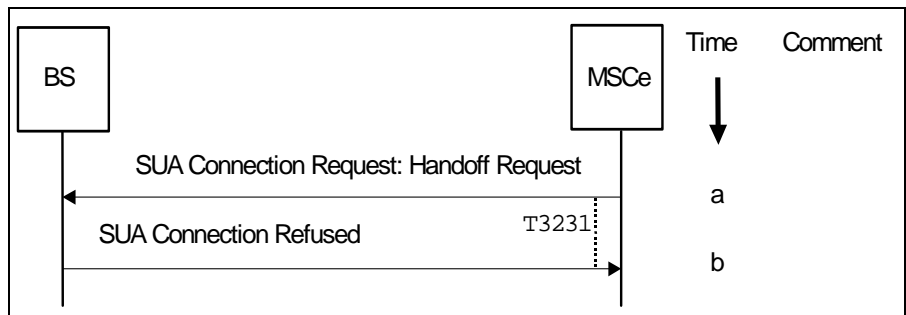

**Figure 3.2.2.6.1.2-2 SUA Connection Refusal During Handoff**

- a. The MSCe sends an SUA Connection Request message, including a user data field that contains a Handoff Request application message, to the BS. The MSCe starts timer T<sub>3231</sub>.
- b. Upon receipt of the SUA Connection Request message, the BS sends an SUA Connection Refused message, which contains the Layer 3 Handoff Failure application message, to the MSCe. Upon receipt of this message, the MSCe stops timer T<sub>3231</sub>.

### 3.2.2.6.2 Connection Release

This procedure is normally initiated at the MSCe side but in the case of abnormal SUA connection release (refer to 3.2.2.6.3), the BS may initiate connection clearing.

The MSCe initiates this procedure with respect to the source BS in normal conditions for all calls supported by A1p connections.

A connection is released when a given signaling connection is no longer required. This may occur in normal cases:

- at the end of a transaction (call, location updating);
- after completion of a successful hard handoff: the connection with the source BS is released.

When either the MSCe or the BS sends an SUA Release Request (RELRE) message, the user data field is optional and may contain a transparent layer 3 message (e.g., DTAP) or be empty. The structure of the user data field, if any, is explained in [14].

When receiving this message, the BS releases or the MSCe initiates release of all the radio resources allocated to the relevant MS, if there are still any left, and returns an SUA Release Complete (RELCO) message.

For abnormal cases a connection failure may be detected by the connection supervision service provided by SUA. For other abnormal SUA connection releases, refer to section 3.2.2.6.3, "Abnormal SUA Release".

### 3.2.2.6.3 Abnormal SUA Release

The normal release of SUA A1p connections is initiated by the MSCe. Under abnormal conditions, an SUA connection may be released by the BS to clear resources.

Whenever an SUA connection is abnormally released, all resources associated with that connection shall be cleared. Abnormal release can result from, for example, resource failure, protocol error, or unexpected receipt of the SUA RELRE or SUA RELCO command.

#### 3.2.2.6.3.1 SUA Release by BS: Loss of SUA Connection Information

Figure 3.2.2.6.3.1-1 demonstrates release of an SUA connection by the BS due to loss of SUA connection information.

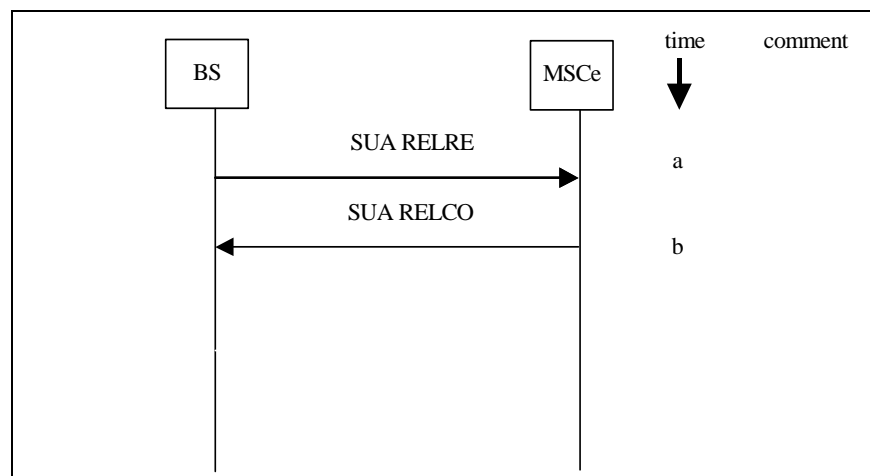

**Figure 3.2.2.6.3.1-1 BS Initiated SUA Release: BS Lost SUA Connection Information**

- An unexpected SUA RELRE message (under abnormal termination) is received by the MSCe from the BS.

- 1                   b. The MSCe sends an SUA RELCO message to the BS to indicate that the SUA
- 2                   RELRE message has been received and that the appropriate procedures have been
- 3                   completed.

4 **3.2.2.6.3.2    SUA Release by MSCe: Loss of SUA Connection Information**

---

5                   Figure 3.2.2.6.3.2-1 demonstrates release of an SUA connection by the MSCe due to loss

6                   of SUA connection information.

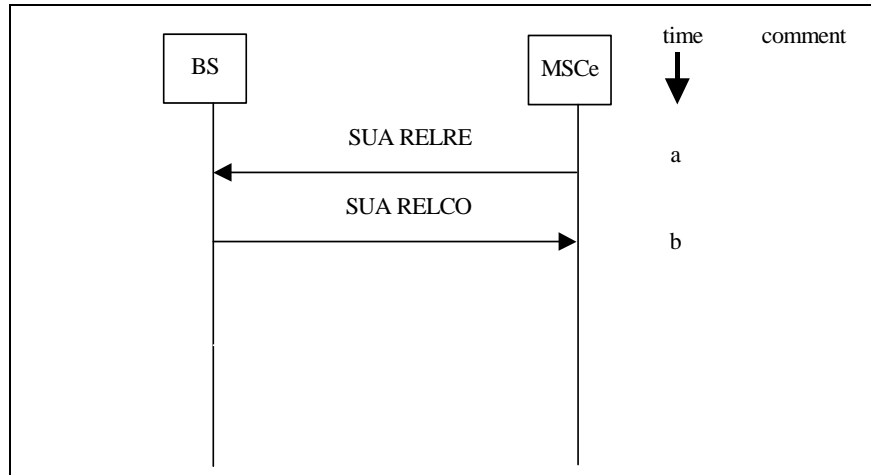

7

8 **Figure 3.2.2.6.3.2-1    MSCe Initiated SUA Release: MSCe Lost SUA Connection Information**

- 9                   a. An unexpected SUA RELRE message (under abnormal termination) is received by
- 10                  the BS from the MSCe.
- 11                  b. The BS sends an SUA RELCO message to the MSCe to indicate that the SUA
- 12                  RELRE message has been received and that the appropriate procedures have been
- 13                  completed.

14 **3.2.2.6.4        SUA Transfer of DTAP and BSMAP Messages**

---

15                  The DTAP and BSMAP messages on the A1p interface are contained in the user data

16                  field of the exchanged SUA frames. Table 3.2.2.6.4-1 below summarizes the use of the

17                  User Data Field in SUA frames.

18

**Table 3.2.2.6.4-1 Use of the User Data Field in SUA Frames**

| SUA Frame                                    | User Data Field (BSMAP/DTAP) |
|--|------------------------------|
| <b>Connection Oriented Protocol Class 2</b>  |                              |
| SUA Connection Request (CORE)                | Optional                     |
| SUA Connection Acknowledge (COAK)            | Optional                     |
| SUA Connection Refused (COREF)               | Optional                     |
| SUA Release Request (RELRE)                  | Optional                     |
| SUA Release Complete (RELCO)                 | Not Applicable               |
| SUA Connection Oriented Data Transfer (CODT) | Mandatory                    |
| <b>Connectionless Protocol Class 0</b>       |                              |
| SUA Connectionless Data Transfer (CLDT)      | Mandatory                    |

For connection oriented transactions, a connection is requested, obtained or refused using the following SUA messages (protocol class 2):

- SUA Connection Request (CORE)
- SUA Connection Acknowledge (COAK)
- SUA Connection Refused (COREF)
- SUA Release Request (RELRE) and SUA Release Complete (RELCO) messages are used to break a connection.

The use of the User Data Field in SUA frames in the various establishment and release cases is described in section 3.2.2.6.1 and section 3.2.2.6.2.

For connection oriented (protocol class 2) transactions, once the signaling connection is confirmed between the MSCe and the BS, all A1p interface messages are transported in the SUA Connection Oriented Data Transfer (CODT) message until the connection is to be dropped.

For Connectionless (protocol class 0) transactions, where there is no SUA connection, A1p interface messages are transported in the SUA Connectionless Data Transfer (CLDT) message.

Table 3.2.2.6.4-2 below indicates which SUA messages shall be used to transport each of the application messages on the A1p interface.

**Table 3.2.2.6.4-2 Use of SUA for BSMAP and DTAP Messages**

| Application Message             | Message Discriminator | SUA Message |
|---------------------------------|-----------------------|-------------|
| <b>Call Processing Messages</b> |                       |             |
| Bearer Update Request           | BSMAP                 | CODT        |
| Bearer Update Required          | BSMAP                 | CODT        |
| Bearer Update Response          | BSMAP                 | CODT        |

**Table 3.2.2.6.4-2 Use of SUA for BSMAP and DTAP Messages**

| <b>Application Message</b>                        | <b>Message Discriminator</b> | <b>SUA Message</b>       |
|---|------------------------------|--------------------------|
| Complete Layer 3 Information                      | BSMAP                        | CORE <sup>a</sup>        |
| CM Service Request                                | DTAP                         | CORE <sup>a,b</sup>      |
| Paging Request                                    | BSMAP                        | CLDT <sup>a</sup>        |
| Paging Response                                   | DTAP                         | CORE <sup>a,b</sup>      |
| CM Service Request Continuation                   | DTAP                         | CODT <sup>c</sup>        |
| Connect   | DTAP                         | CODT                     |
| Progress  | DTAP                         | CODT                     |
| Service Release                                   | DTAP                         | CODT                     |
| Service Release Complete                          | DTAP                         | CODT                     |
| Assignment Request                                | BSMAP                        | COAK <sup>d</sup> , CODT |
| Assignment Complete                               | BSMAP                        | CODT                     |
| Assignment Failure                                | BSMAP                        | CODT                     |
| Clear Request                                     | BSMAP                        | CODT                     |
| Clear Command                                     | BSMAP                        | CODT                     |
| Clear Complete                                    | BSMAP                        | CODT                     |
| Alert With Information                            | DTAP                         | CODT                     |
| BS Service Request                                | BSMAP                        | CLDT                     |
| BS Service Response                               | BSMAP                        | CLDT                     |
| Additional Service Request                        | DTAP                         | CODT                     |
| Additional Service Notification                   | BSMAP                        | CODT                     |
| <b>Supplementary Services Messages</b>            |                              |                          |
| Flash with Information                            | DTAP                         | CODT                     |
| Flash with Information Ack                        | DTAP                         | CODT                     |
| Feature Notification                              | BSMAP                        | CLDT <sup>a</sup>        |
| Feature Notification Ack                          | BSMAP                        | CLDT <sup>a</sup>        |
| Priority Access Channel Assignment (PACA) Command | BSMAP                        | COAK <sup>d</sup> , CODT |
| PACA Command Ack                                  | BSMAP                        | CODT                     |
| PACA Update                                       | BSMAP                        | CLDT                     |
| PACA Update Ack                                   | BSMAP                        | CLDT                     |
| Radio Measurements for Position Request           | BSMAP                        | CODT                     |
| Radio Measurements for Position Response          | BSMAP                        | CODT                     |
| <b>Mobility Management Messages</b>               |                              |                          |
| Authentication Request                            | DTAP/BSMAP                   | CODT, CLDT <sup>c</sup>  |
| Authentication Response                           | DTAP/BSMAP                   | CODT, CLDT <sup>c</sup>  |

**Table 3.2.2.6.4-2 Use of SUA for BSMAP and DTAP Messages**

| <b>Application Message</b>                               | <b>Message Discriminator</b> | <b>SUA Message</b>      |
|--|------------------------------|-------------------------|
| SSD Update Request                                       | DTAP                         | CODT                    |
| Base Station Challenge                                   | DTAP                         | CODT                    |
| Base Station Challenge Response                          | DTAP                         | CODT                    |
| BS Authentication Request                                | BSMAP                        | CODT                    |
| BS Authentication Request Ack                            | BSMAP                        | CODT                    |
| Status Request   | DTAP/BSMAP                   | CODT, CLDT <sup>c</sup> |
| Status Response  | DTAP/BSMAP                   | CODT, CLDT <sup>c</sup> |
| SSD Update Response                                      | DTAP                         | CODT                    |
| Location Updating Request                                | DTAP                         | CORE <sup>a,b</sup>     |
| Location Updating Accept                                 | DTAP                         | COREF                   |
| Location Updating Reject                                 | DTAP                         | COREF                   |
| Mobile Station Registered Notification                   | BSMAP                        | CODT                    |
| Parameter Update Request                                 | DTAP                         | CODT                    |
| Parameter Update Confirm                                 | DTAP                         | CODT                    |
| Privacy Mode Command                                     | BSMAP                        | CODT                    |
| Privacy Mode Complete                                    | BSMAP                        | CODT                    |
| Registration Request                                     | BSMAP                        | CLDT                    |
| User Zone Reject   | DTAP/BSMAP                   | CODT, CLDT <sup>c</sup> |
| User Zone Update   | DTAP                         | CODT                    |
| User Zone Update Request                                 | DTAP                         | CODT                    |
| <b>Handoff Messages</b>                                  |                              |                         |
| Handoff Required   | BSMAP                        | CODT                    |
| Handoff Request  | BSMAP                        | CORE                    |
| Handoff Request Acknowledge                              | BSMAP                        | COAK                    |
| Handoff Failure  | BSMAP                        | COREF <sup>f</sup>      |
| Handoff Command  | BSMAP                        | CODT                    |
| Handoff Required Reject                                  | BSMAP                        | CODT                    |
| Handoff Commenced  | BSMAP                        | CODT                    |
| Handoff Complete   | BSMAP                        | CODT                    |
| Handoff Performed  | BSMAP                        | CODT                    |
| <b>Facilities Management Messages</b>                    |                              |                         |
| Reset  | BSMAP                        | CLDT                    |
| Reset Acknowledge  | BSMAP                        | CLDT                    |
| Service Redirection                                      | DTAP                         | CODT, COREF             |
| <b>Application Data Delivery Service (ADDS) Messages</b> |                              |                         |
| ADDS Page  | BSMAP                        | CLDT                    |

**Table 3.2.2.6.4-2 Use of SUA for BSMAP and DTAP Messages**

| <b>Application Message</b>     | <b>Message Discriminator</b> | <b>SUA Message</b>      |
|--------------------------------|------------------------------|-------------------------|
| ADDS Transfer                  | BSMAP                        | CLDT                    |
| ADDS Deliver                   | DTAP                         | CODT                    |
| ADDS Page Ack                  | BSMAP                        | CLDT                    |
| ADDS Deliver Ack               | DTAP                         | CODT                    |
| ADDS Transfer Ack              | BSMAP                        | CLDT                    |
| <b>Error Handling Messages</b> |                              |                         |
| Rejection                      | DTAP/BSMAP                   | CODT, CLDT <sup>e</sup> |

1  
2  
3  
4  
5  
6  
7  
8  
9  
10  
11  
12  
13  
14  
15  
16  
17  
18  
19  
20

Following are the footnotes referred to in Table 3.2.2.6.4-2.

- a. Required, SUA CODT is not an option.
- b. Sent within Complete Layer 3 Information, which is a BSMAP message.
- c. This message may be used in addition to the CM Service Request.
- d. May be used if responding to a CM Service Request or Paging Response.
- e. Used only when the procedure is done on a paging channel.
- f. May be used if responding to an SUA Connection Request/Handoff Request.

**3.2.2.7 Base Station Application Part on A1p**

---

The Base Station Application Part is specified in section 2.9.

**3.2.2.8 Use of SCTP**

---

The A1p interface shall use SCTP as specified in section 2.10.

SCTP port value 14001 is used for SUA on the A1p interface.

**3.2.3 A2p User Traffic Transport Protocol**

---

The protocol stack options for transport of user traffic over A2p that are available to operators and manufacturers are shown in Figure 3.2.3-1 to Figure 3.2.3-4.

- a. Figure 3.2.3-1 is used for EVRC or SMV. Refer to [41].
- b. Figure 3.2.3-2 is used for PCM (G.711). Refer to [40].
- c. Figure 3.2.3-3 is used for 13K. Refer to [34].
- d. Figure 3.2.3-4 is used for DTMF. Refer to [36].

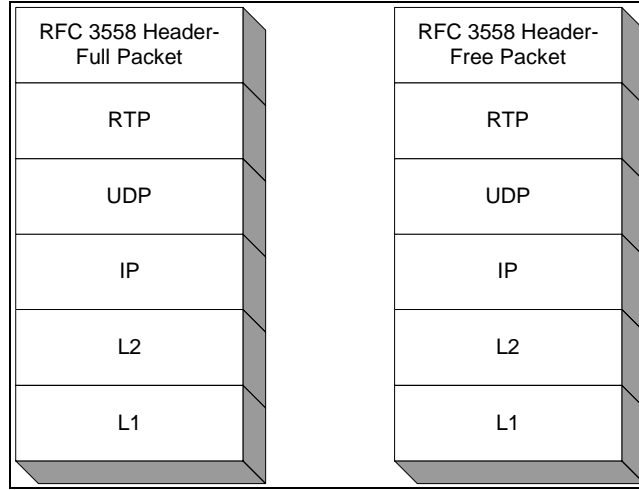

1  
2  
3

**Figure 3.2.3-1**

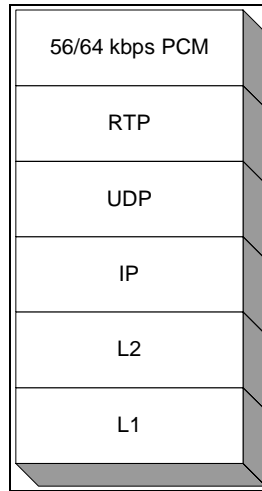

4  
5  
6

**Figure 3.2.3-2**

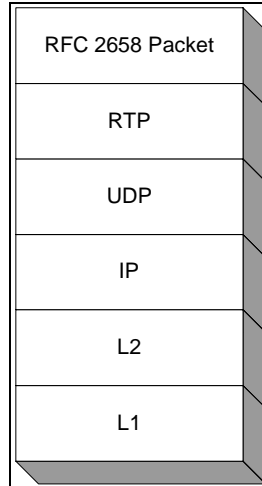

1  
2  
3  
**Figure 3.2.3-3**

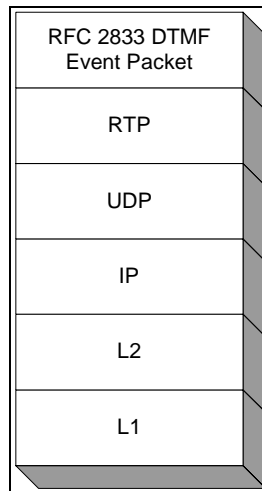

4  
5  
**Figure 3.2.3-4**

6 **3.2.3.1 Physical Layer (L1) Specification for A2p**

---

7 The A2p interface shall use one of the L1 specifications in section 2.1.

8 **3.2.3.2 Layer 2 Specification for A2p**

---

9 The A2p L2 requirements as specified in section 2.2 may apply as per inter-vendor  
10 agreements.

11 **3.2.3.3 Use of IP for A2p**

---

12 The requirements for 2.4.1 and 2.4.2 may apply as per inter-vendor agreements.

13 **3.2.3.4 QoS Specifications for A2p**

---

14 The A2p QoS requirements are for further study.

### 3.2.3.5 Security Specifications for A2p

The A2p Security Framework requirements are specified in section 2.4.5.

## 3.3 A3 and A7 Interfaces

Two protocol stacks are defined for the A3 and A7 signaling interface, and two protocol stacks are defined in this standard for the A3 user traffic interface.

As a mandatory requirement, the BS shall implement the ATM-based protocol stack. As an option, the IP-based protocol stack may be implemented at the BS.

### 3.3.1 Performance Specifications

The following parameters shall be specified by the required performance specifications on the A3/A7 interfaces:

- **ISD:** This is composed of the cumulative queuing, transmission, and propagation delays across the transport network between nodes supporting the A3/A7 interface. ISD is specified as a statistical variable (e.g. 99.9<sup>th</sup> percentile) allowing for delay variation (e.g. jitter). The delay budget for each hop in the transport network is not specified but rather each deployment or implementation should be engineered to meet the ISD using, for example, the link rate and technology at L1/L2.
- **ISL:** This is the packet loss across the transport network between nodes supporting the A3/A7 interface. ISL includes two components of packet loss in IP transport networks, queue overflow and errors on the transmission media. An implementation may choose to specify a packet loss rate that does not significantly impact the overall performance of the system while enabling a practical physical layer transmission network to be employed.

The performance of the A3/A7 interfaces has a significant impact on a subscriber's service quality. The RAN components supporting the fundamental channel (FCH), dedicated control channel (DCCH), and supplemental channel (SCH), on the A3/A7 interface shall conform to the delay budget requirements in Table 3.3.1-1.

The delay between the source BS and target BS (channel element) includes the ISD and network entity processing delays. The forward delay is the 99.9 percentile delay measured from the time the first bit of the frame is transmitted from the source BS to the time the first bit of the frame is transmitted over the air interface at the channel element for any soft handoff leg. The reverse delay is the 99.9 percentile delay measured from the time the last bit of the frame is received on the air interface at the channel element of any soft handoff leg to the time the last bit of the frame is received at the source BS.

**Table 3.3.1-1 Delay Budget Requirements**

| Traffic type                         | IOS BSC-BTS | IOS BSC-BTS<br>w/Turbo coding | A3 ISD |
|--------------------------------------|-------------|-------------------------------|--------|
| IS-95/IS-2000<br>FCH/DCCH<br>forward | 50 ms       | N/A                           | 10 ms  |
| IS-95/IS-2000<br>FCH/DCCH<br>reverse | 60 ms       | N/A                           | 10 ms  |
| IS-2000 SCH<br>forward               | 55 ms       | 55 ms                         | 15 ms  |

| <b>Traffic type</b>    | <b>IOS BSC-BTS</b> | <b>IOS BSC-BTS<br/>w/Turbo coding</b> | <b>A3 ISD</b> |
|------------------------|--------------------|---------------------------------------|---------------|
| IS-2000 SCH<br>reverse | 65 ms              | 75 ms                                 | 15 ms         |

1    **3.3.1.1                    Performance Specification for IP Protocol Stacks**

---

2                    If QoS is required (refer to section 2.4.4), the BSs on the A3/A7 interfaces shall employ  
3                    Diffserv [33] marking for traffic as per the classes in Table 3.3.1.1-1. The transport  
4                    network shall use this class information to meet the specified ISD and ISL on the  
5                    particular interface, as given in Table 3.3.1.1-1.

6

1 **Table 3.3.1.1-1 A3/A7 Mapping Between Traffic Classes and Service-Level QoS**

| Traffic Classes      | Mandatory Traffic Types      | Optional Traffic Types                             | 99.9 %-tile Interface Service Delay (includes jitter) | Interface Service Packet Loss Rate |
|----------------------|------------------------------|--|---|------------------------------------|
| Class 1              | FCH and DCCH frame protocols | Very low latency control and/or signaling messages | 10 ms   | 1.e-5                              |
| Class 2              | SCH frame protocol           | Low latency control and/or signaling messages      | 15 ms   | 1.e-4                              |
| Class 3 <sup>a</sup> | None.                        | Normal signaling Messages                          | 100 ms  | 1.e-4                              |
| Class 4 <sup>a</sup> | None.                        | OAM&P messages                                     | 2 sec   | 1.e-3                              |

2 a. The ISD and ISL values for these classes are suggested values.

### 3 3.3.2 A3 User Traffic Transport Requirements

4 The protocol stack options for transport of user traffic that are available to operators and  
5 manufactures are shown in Figure 3.3.2-1.

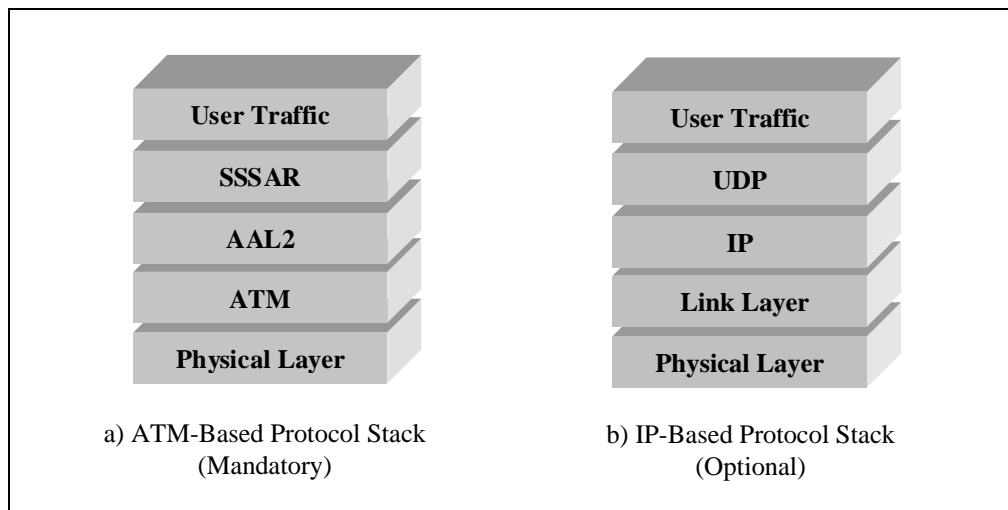

8 **Figure 3.3.2-1 A3 User Traffic Protocol Stack**

#### 9 3.3.2.1 ATM-Based User Traffic Transport

10 The A3 user traffic interface, when implementing an ATM-based protocol stack, shall contain the layers shown in a) of Figure 3.3.2-1.

##### 11 3.3.2.1.1 Physical Layer (L1) Specification

12 The A3 user traffic interface shall use one of the L1 specifications in section 2.1.

---

**1 3.3.2.1.2 Use of ATM**

---

2 For this specification only ATM PVCs shall be required for the A3 user traffic interface.  
3 These virtual circuits shall be configured through administrative procedures and no  
4 special signaling interface procedures, e.g., ATM User Network Interface (UNI) [26],  
5 shall be required.

---

**6 3.3.2.1.3 Use of AAL2**

---

7 When ATM is used to provide user traffic (voice/data) transport, the AAL2 protocol is  
8 used. The procedures defined in [15] determine the allocation and use of the logical  
9 channels, i.e., the connection identifiers (CIDs) that AAL2 provides over an ATM virtual  
10 circuit.

11 Each BS has one or more ATM virtual circuits that connect it to other BSs (regardless of  
12 whether switched or permanent virtual circuits are used). These virtual circuits are  
13 comprised of one or more virtual circuits using AAL2 for the user traffic connections.

---

**14 3.3.2.2 IP-Based User Traffic Transport**

---

15 The A3 user traffic interface, when implementing an IP-based protocol stack, shall  
16 contain the protocol layers shown in b) of Figure 3.3.2-1.

17 The requirements of this section shall apply to the transport layer for the A3 user traffic  
18 frames.

---

**19 3.3.2.2.1 Physical Layer (L1) Specification**

---

20 The A3 user traffic interface shall use one of the L1 specifications in section 2.1.

---

**21 3.3.2.2.2 Layer 2 Specification**

---

22 The A3 user traffic L2 requirements as specified in section 2.2 shall apply for the  
23 following areas:

- 24 • Bandwidth efficiency
- 25 • Delay/jitter control
- 26 • Multiplexing
- 27 • Compression
- 28 • Segmentation and re-assembly (SAR)
- 29 • Error detection
- 30 • Addressing

---

**31 3.3.2.2.3 Use of IP**

---

32 The following requirements are valid for the IP network, when it is used for A3 user  
33 traffic:

- 34 • The A3 bearer transport topology options are specified in section 2.4.1.
- 35 • The standard IP protocol, as defined in [28], shall be used for routing A3 user traffic.
- 36 • The A3 bearer transport network addressing shall support a class-less IP addressing  
37 scheme as specified in section 2.4.2.1.

- 1 • The A3 bearer transport network routing requirements are specified in section
- 2 2.4.2.2.
- 3 • The A3 bearer flow association guidelines are specified in section 2.4.2.3. Specific
- 4 flow association requirements for A3 bearer frames are as follows:
- 5 – Every unidirectional soft handoff leg (i.e. logical A3 bearer path between a
- 6 Selector/Distribution Unit (SDU) frame selector and a BTS channel element)
- 7 shall be addressed via an IP address and a UDP port number.
- 8 – Unique IP addresses and UDP port numbers may be assigned in the forward and
- 9 reverse directions.
- 10 – The target side IP address and UDP port number pair shall uniquely identify a
- 11 connection.

12 **3.3.2.2.4 QoS Specifications**

---

13 The A3 bearer QoS requirements are specified in sections 2.4.4 and 3.3.1.1.

14 The A3 bearer mapping between Traffic Classes and Service-Level QoS requirements are

15 specified in Table 3.3.1.1-1.

16 **3.3.2.2.5 Security Specifications**

---

17 The A3 bearer Security Framework requirements are specified in section 2.4.5.

18 **3.3.3 A3/A7 Signaling Transport Requirements**

---

19 The two signaling protocol stack options that are available to operators and

20 manufacturers for the A3 and A7 signaling interfaces include:

21

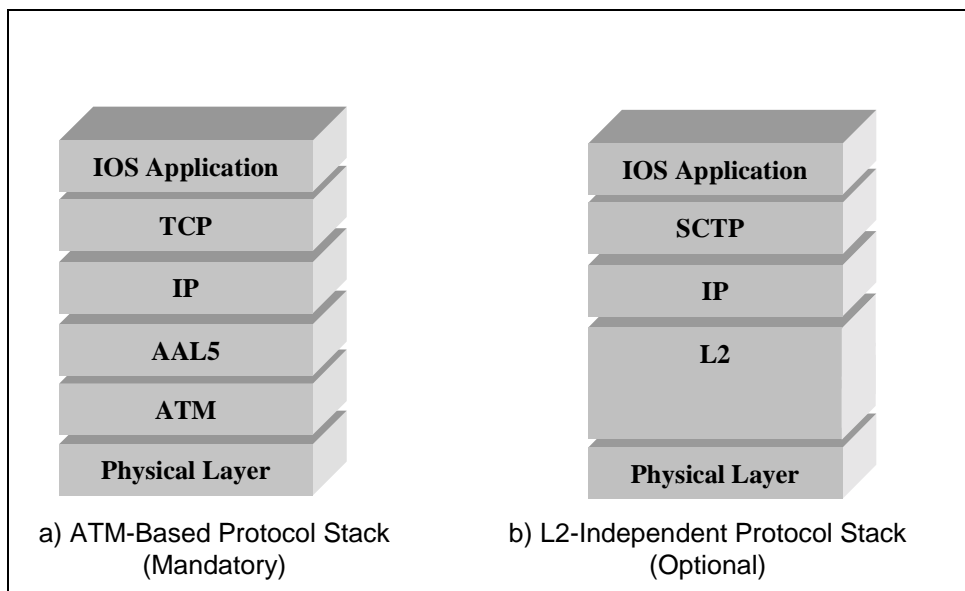

22

23

**Figure 3.3.3-1 A3 and A7 Signaling Protocol Stack**

|    |                  |  |
|----|------------------|--|
| 1  | <b>3.3.3.1</b>   | <b>ATM-Based Signaling Protocol Stack</b>  |
| 2  |                  | The A3/A7 Signaling interfaces, when using an ATM-based protocol stack, shall contain  |
| 3  |                  | the layers shown in a) of Figure 3.3.3-1.  |
| 4  | <b>3.3.3.1.1</b> | <b>Use of Physical Layer</b>   |
| 5  |                  | The A3/A7 signaling interfaces shall use one of the specification defined in section 2.1.  |
| 6  | <b>3.3.3.1.2</b> | <b>Use of ATM</b>  |
| 7  |                  | For this specification only ATM PVC shall be required for the A3 and A7 signaling  |
| 8  |                  | interfaces. These virtual circuits shall be configured through administrative procedures   |
| 9  |                  | and no special signaling interface procedures, e.g., ATM UNI [26], shall be required.  |
| 10 |                  | When ATM is used to provide signaling transport, the AAL5 protocol is employed.  |
| 11 |                  | Each BS has one or more ATM virtual circuits that connect it to other BSs (regardless of   |
| 12 |                  | whether switched or permanent virtual circuits are used). These virtual circuits are   |
| 13 |                  | comprised of one or more virtual circuits using the AAL5 protocol for signaling.   |
| 14 | <b>3.3.3.1.3</b> | <b>Use of AAL5</b>   |
| 15 |                  | The AAL5 requirements are specified in section 2.3.1.  |
| 16 | <b>3.3.3.1.4</b> | <b>Use of IP</b>   |
| 17 |                  | The IP requirements are specified in section 2.3.2.  |
| 18 | <b>3.3.3.1.5</b> | <b>Use of TCP</b>  |
| 19 |                  | The standard TCP, as described in [29] and shown in section 2.5 shall be used on the A3  |
| 20 |                  | (signaling subchannel) and A7 interfaces.  |
| 21 |                  | All response messages associated with the handoff procedures shall be sent back to the   |
| 22 |                  | same TCP connection where the first A3 or A7 message initiating the procedure is   |
| 23 |                  | received. For example, the A3-Connect Ack (refer to [15]) message is sent back to the  |
| 24 |                  | same TCP connection from which the A3-Connect message is received.   |
| 25 |                  | Any A3 or A7 signaling link disconnection during a handoff procedure may result in a   |
| 26 |                  | failure of the handoff procedure. Optionally, a connection recovery may be performed for   |
| 27 |                  | continuation of the handoff procedures. If a connection recovery is performed, the same  |
| 28 |                  | active-passive TCP establishment procedure shall be used.  |
| 29 |                  | The following TCP port values are reserved for signaling across A7 interfaces:   |
| 30 |                  | <ul style="list-style-type: none"><li>• A7: (BS-to-BS) 5602 — This is the registered TCP port at a BS used for signaling</li></ul> |
| 31 |                  | interconnection to another BS.   |
| 32 | <b>3.3.3.2</b>   | <b>IP-Based Signaling Protocol Stack</b>   |
| 33 |                  | The A3/A7 Signaling interfaces, when implementing the L2-independent protocol stack,   |
| 34 |                  | shall contain the layers shown in b) of Figure 3.3.3-1.  |

1    **3.3.3.2.1    Use of Physical Layer**

---

2    The A3/A7 signaling interface shall use one of the L1 specifications in section 2.1.

3    **3.3.3.2.2    Layer 2 Specification**

---

4    The A3/A7 signaling transport L2 requirements are specified in section 2.2 shall apply  
5    for the following areas:

- 6    • Bandwidth efficiency
- 7    • Delay/jitter control
- 8    • Multiplexing
- 9    • Compression
- 10    • Segmentation and re-assembly (SAR)
- 11    • Error detection
- 12    • Addressing

13    **3.3.3.2.3    Use of IP**

---

14    The following requirements are valid for the IP network, when used for A3/A7 signaling  
15    transport:

- 16    • The A3/A7 signaling transport topology options are described in section 2.4.1.
- 17    • The standard IP protocol, as defined in [28], shall be used for routing A3/A7  
18    signaling.
- 19    • The A3/A7 signaling transport IP network shall support a class-less IP addressing  
20    scheme as specified in section 2.4.2.1.
- 21    • The A3/A7 signaling transport network routing requirements are specified in section  
22    2.4.2.2.
- 23    • The A3/A7 signaling transport flow association guidelines are specified in section  
24    2.4.2.3. Specific flow association requirements for A3/A7 signaling are as follows:
  - 25    – Every logical signaling (i.e., BS) point defined in A3 or A7 interfaces that may  
26    be a signaling source or target (e.g., BS source or target) shall be individually  
27    addressable via an IP address and TCP or SCTP port number.
  - 28    – When using the SCTP-based protocol, messages associated with individual  
29    traffic connections shall contain unique SCTP stream identifiers.

30    **3.3.3.2.4    QoS Specifications**

---

31    The A3/A7 signaling transport QoS requirements are specified in sections 2.4.4 and  
32    3.3.1.1.

33    The A3/A7 signaling transport mapping between Traffic Classes and Service-Level QoS  
34    requirements are specified in Table 3.3.1.1-1.

35    **3.3.3.2.5    Security Specifications**

---

36    The A3/A7 signaling transport security Framework requirements are specified in section  
37    2.4.5.

### 3.3.3.2.6 Use of SCTP

The L2-Independent Protocol Stack on the A3 and A7 signaling interface shall use SCTP as specified in section 2.10.

Between BSs (e.g., A3 and A7), one or several SCTP associations may exist. A BS may select an SCTP association at creation of a user session context. However, it may not be very efficient to consider each association as a signaling connection because typical requirements of signaling application transport can be fulfilled by an SCTP stream pair. Therefore, it should be assumed that one SCTP association is an aggregation of signaling application connections. As such, each signaling application connection shall be mapped to a pair of SCTP streams (one in downlink and one in uplink). The choice of stream identifiers should be a function of the user application. One simple solution is to choose the same stream identifier for each of the two streams comprising the connection.

SCTP port value 5604 is used for A7 signaling.

## 3.4 A8 and A9 Interfaces

The A8 and A9 interfaces are based on the use of IP. IP can operate across various physical layer media. The specific layer 1 media and layer 2 link protocols to be used for these interfaces are not specified in this standard.

Signaling over the A9 interface requires a reliable transport protocol and appropriate addressing and routing mechanisms to deliver messages from source to destination. The signaling protocol stack option available to operators and manufacturers for the A9 interface is shown in Figure 3.4-1.

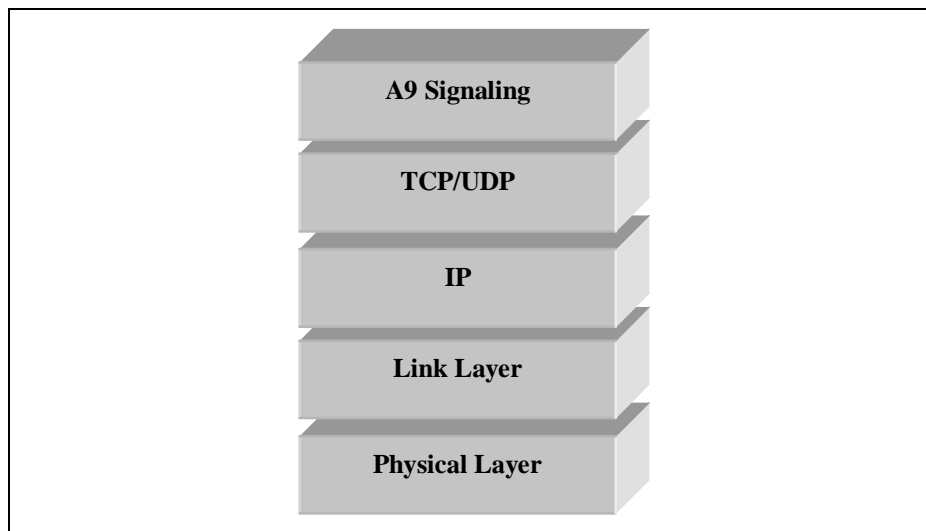

**Figure 3.4-1 A9 Signaling Protocol Stack**

The protocol stack options for transport of user traffic that are available to operators and manufacturers are shown in Figure 3.4-2.

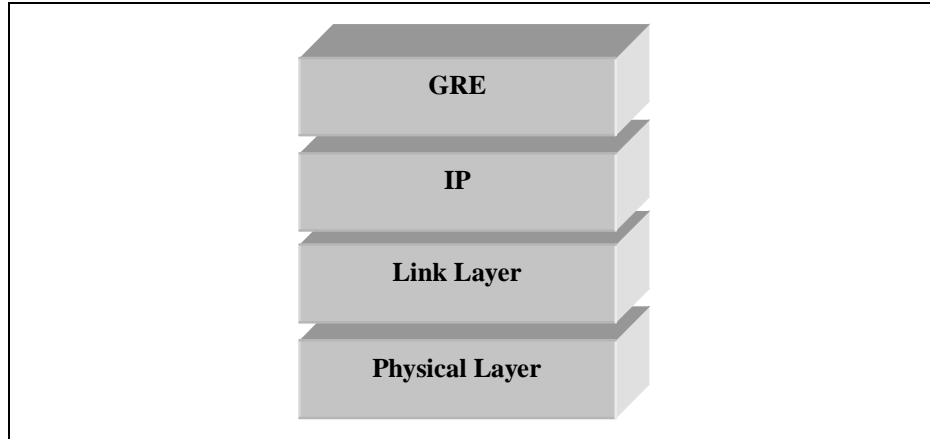

Figure 3.4-2 A8 User Traffic Protocol Stack

### 3.4.1 Use of TCP

---

When TCP is used for transferring the A9 interface messages, the standard TCP, as described in [29] and shown in section 2.5, shall be used. The following TCP port value is reserved for signaling across the A9 interface:

- A9: (BS-to-PCF) 5603 — This is the registered TCP/UDP port at a BS used for signaling interconnection to a PCF.

### 3.4.2 Use of UDP

---

When UDP is used for transferring the A9 interface messages, the standard UDP, as described in [27], shall be used.

UDP Port value '5603' is reserved for signaling use on the A9 interface. The initiator (BS) of an A9 link picks an available source UDP port, and sends an A9-Setup-A8 message (refer to [16]) to the destination (PCF) at port 5603. The PCF responds with an A9-Connect-A8 message to the UDP port of the BS that initiated the A9-Setup-A8 message (refer to [16]).

### 3.4.3 Use of GRE

---

For general use of GRE, refer to section 2.6.

The BS shall set the Key field in the GRE header to the value in the Key field in the A8 Traffic ID element in the A9-Connect-A8 message received from the PCF indicating that the PCF accepts the A8 connection. The PCF shall set the Key field in the GRE header to the value in the Key field in the A8 Traffic ID element in the A9-Setup-A8 message received from the BS requesting the establishment of the A8 connection. Refer to [16] for details on these A9 messages.

On the A8 interface, no attributes have been defined (refer to section 2.6.1) that may be included in the GRE frames when the Protocol Type field is set to "3GPP2 Packet".

## 3.5 A10 and A11 Interface

The A10 and A11 interfaces are based on the use of IP. IP can operate across various physical layer media. The specific layer 1 media and layer 2 link protocols to be used for these interfaces are not specified in this standard.

Mobile IP based messages are used for A11 interface call control signaling and for passing accounting related and other information from the PCF to the PDSN (refer to [17] for details). Each signaling exchange consists of a request message and a reply message. When a message is sent by the PCF, the PCF's A11 IP address shall be used as the IP Source Address and the PDSN's A11 IP shall be used as the IP Destination Address. When a message is sent by the PDSN, the PDSN's A11 IP address shall be used as the IP Source Address and the PCF's A11 IP address shall be used as the IP Destination Address. Each message is transported within a UDP datagram. The initiator of the request message shall pick an available UDP source port, and set the UDP destination port to 699 in the request message it sends to the selected receiver. In the reply message it sends to the initiator, the receiver shall pick an available UDP source port (it can use the UDP destination port in the request message) and set the UDP destination port to the UDP source port in the request message.

Signaling over the A11 interface requires a reliable transport protocol and appropriate addressing and routing mechanisms to deliver messages from source to destination. The signaling protocol stack option available to operators and manufacturers for the A11 interface is shown in Figure 3.5-1.

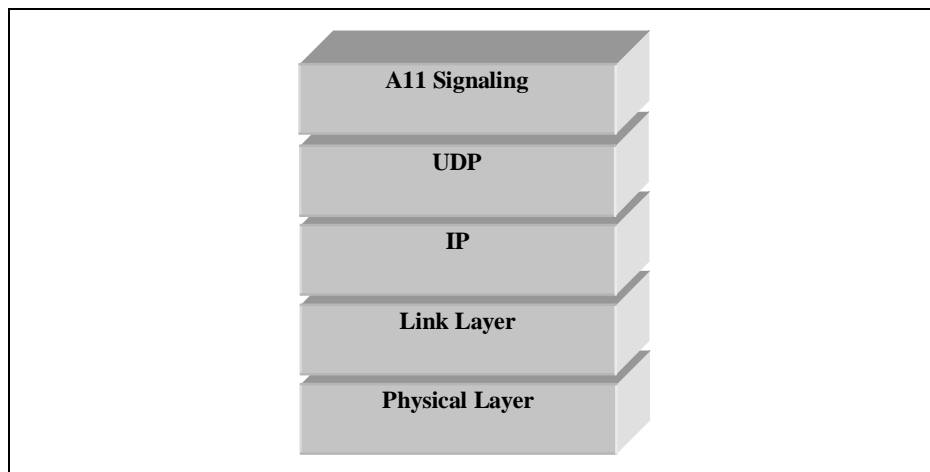

**Figure 3.5-1 A11 Signaling Protocol Stack**

The protocol stack option for transport of user traffic that is available to operators and manufacturers is shown in Figure 3.5-2.

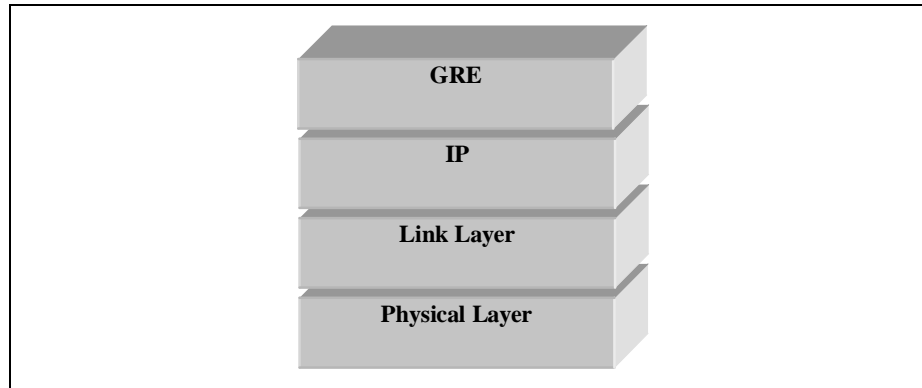

**Figure 3.5-2 A10 User Traffic Protocol Stack**

### 3.5.1 Use of UDP

---

The use of UDP over the A11 interface conforms to the use of UDP for Mobile IP, as specified in [31] with the exception of the UDP port number.

### 3.5.2 Use of GRE

---

For general use of GRE, refer to section 2.6.

The PCF shall set the Key field in the GRE header to the value in the Key field in the Session Specific Extension in the A11-Registration Reply message received from the PDSN indicating that the PDSN accepts the A10 connection. The PDSN shall set the Key field in the GRE header to the value in the Key field in the Session Specific Extension in the A11-Registration Request message received from the PCF requesting the establishment of the A10 connection. Refer to [17] for details on these A11 messages.

On the A10 interface, valid attributes (refer to section 2.6.1) that may be included in the GRE frames when the Protocol Type field is set to “3GPP2 Packet” include:

- Short Data Indicator
- Flow Control Indication

1  
2  
3  
4  
5  
6

(This page intentionally left blank.)