

1  
2  
3  
4  
5  
6  
7  
8  
9  
10  
11  
12  
13  
14  
15  
16  
17  
18  
19  
20  
21

**3GPP2 A.S0011-C**  
**Version 2.0**  
**Date: December 2005**



**3RD GENERATION  
PARTNERSHIP  
PROJECT 2  
"3GPP2"**

---

# Interoperability Specification (IOS) for cdma2000 Access Network Interfaces — Part 1 Overview

## **(3G-IOS v5.0.1)**

COPYRIGHT

3GPP2 and its Organizational Partners claim copyright in this document and individual Organizational Partners may copyright and issue documents or standards publications in individual Organizational Partner's name based on this document. Requests for reproduction of this document should be directed to the 3GPP2 Secretariat at [secretariat@3gpp2.org](mailto:secretariat@3gpp2.org). Requests to reproduce individual Organizational Partner's documents should be directed to that Organizational Partner. Refer to [www.3gpp2.org](http://www.3gpp2.org) for more information.



# Table of Contents

1			
2			
3	1.0	Introduction .....	1
4	1.1	Overview .....	1
5	1.1.1	Purpose .....	1
6	1.1.2	Scope .....	3
7	1.1.3	New Features and Enhancements in this Release .....	4
8	1.2	References .....	4
9	1.2.1	3GPP2 and TIA/EIA .....	4
10	1.2.2	Other .....	5
11	1.3	Terminology .....	5
12	1.3.1	Acronyms .....	5
13	1.3.2	Definitions .....	6
14	1.4	Organization .....	10
15	1.4.1	Overall IOS Specifications .....	10
16	1.5	Document Layout .....	11
17	1.6	Documentation Conventions .....	12
18	1.6.1	Procedural Descriptions .....	13
19	2.0	Interface Model .....	15
20	2.1	Reference Points A, A <sub>ter</sub> , A <sub>quinter</sub> , A <sub>quater</sub> , 48 and 27 .....	15
21	2.2	Interface Reference Model .....	15
22	3.0	Information Flows .....	19
23	4.0	MS Mobility for Packet Data Service.....	21
24			
25			
26			

## List of Figures

1  
2  
3  
4  
5  
6  
7  
8

Figure 1.6-1	Document Convention Example: Call Clear Initiated by MS .....	13
Figure 2.2-1	Reference Model for Circuit Switched cdma2000 Access Network Interfaces.....	16
Figure 2.2-2	Reference Model for Packet-based cdma2000 Access Network Interfaces.....	17
Figure 4-1	Levels of Packet Data Mobility .....	21

## List of Tables

1  
2  
3  
4  
5

Table 1.4.1-1 IOS Cross References..... 11

# Foreword

(This foreword is not part of this standard.)

This document was produced by TSG-A of the Third Generation Partnership Project 2. This document was developed in accordance with the procedural guidelines of 3GPP2 and its Organizational Partners, and represents the consensus position of these groups.

The following table indicates which parts of the base document are modified by the incorporation of this revision.

Base Document	Title	Document	Notes
A.S0011-C v1.0	Interoperability Specification (IOS) for cdma2000 Access Network Interfaces — Part 1 Overview	A.S0011-C v2.0	Changes relative to the base document.
A.S0012-C v1.0	Interoperability Specification (IOS) for cdma2000 Access Network Interfaces — Part 2 Transport	A.S0012-C v2.0	No changes relative to the base document.
A.S0013-C v1.0	Interoperability Specification (IOS) for cdma2000 Access Network Interfaces — Part 3 Features	A.S0013-C v2.0	Changes relative to the base document.
A.S0014-C v1.0	Interoperability Specification (IOS) for cdma2000 Access Network Interfaces — Part 4 (A1, A2, and A5 Interfaces)	A.S0014-C v2.0	Changes relative to the base document.
A.S0015-C v1.0	Interoperability Specification (IOS) for cdma2000 Access Network Interfaces — Part 5 (A3 and A7 Interfaces)	A.S0015-C v2.0	No changes relative to the base document
A.S0016-C v1.0	Interoperability Specification (IOS) for cdma2000 Access Network Interfaces — Part 6 (A8 and A9 Interfaces)	A.S0016-C v2.0	No changes relative to the base document
A.S0017-C v1.0	Interoperability Specification (IOS) for cdma2000 Access Network Interfaces — Part 7 (A10 and A11 Interfaces)	A.S0017-C v2.0	Changes relative to the base document

Note, that the cover page and headers for documents with no changes relative to the base document are updated to keep the numbering of the document set consistent.

Suggestions for improvement of this standard are welcome. They should be sent to:

Director, 3GPP2  
250 Wilson Boulevard, Suite 300  
Arlington, VA 22201 USA

## 1.0 Introduction

---

### 1.1 Overview

---

This standard describes the overall system functions, including services and features required for interfacing a base station (BS) to a Mobile Switching Center (MSC), Mobile Switching Center Emulation (MSCe), Media Gateway (MGW), other BSs, and a Packet Control Function (PCF). It further describes the interface between a PCF and a Packet Data Service Node (PDSN). These interfaces are based on interoperation with the cdma2000<sup>®1</sup> air interface [1]~[6], the wireless IP network [8] and the ANSI-41 core network [9].

This standard is intended to provide sufficient specification of a set of interfaces to support the interoperability of one vendor's equipment with that of another. Which interface(s) a vendor chooses to implement is dependent on business decisions, and is up to each vendor. However conformance to any given interface specified within this standard requires all of the messages and procedures for supported features on that interface to be supported as specified within this standard. Establishing standard interfaces allows the BS, MSC MSCe, MGW, PCF, and PDSN equipment to evolve independently and to be provided by multiple vendors.

#### 1.1.1 Purpose

---

The purpose is to provide the standard for:

- interfacing a circuit switched MSC with one or more BSs,
- interfacing an MSCe with one or more BSs,
- interfacing an MGW with one or more BSs,
- interfacing a BS with one or more BSs,
- interfacing a PCF with one or more BSs,
- interfacing one or more PDSNs with one or more PCFs.

This document defines the functional capabilities, including services and features, of the specified interfaces. These services and features are the defining characteristics that are the basis for the overall system standard.

The MSC-BS interface provides telecommunications services access between a Mobile Switching Center and a base station. It specifically represents the demarcation point between the MSC and the BS which coincides with the Reference Point "A". This point establishes the technical interface and designates the test points and operational division of responsibility between the MSC and the BS. The MSC and BS interface is defined as the A1/A2/A5 interface shown in Figure 2.2-1.

---

<sup>1</sup> cdma2000<sup>®</sup> is the trademark for the technical nomenclature for certain specifications and standards of the Organizational Partners (OPs) of 3GPP2. Geographically (and as of the date of publication), cdma2000<sup>®</sup> is a registered trademark of the Telecommunications Industry Association (TIA-USA) in the United States.

1 The MSCe-BS interface provides telecommunications services access between an MSCe  
2 and a BS. It specifically represents the demarcation point between the MSCe and the BS,  
3 which coincides with the Reference Point 48 [19]. This point establishes the technical  
4 interface and designates the test points and operational division of responsibility between  
5 the MSCe and the BS. The MSCe and BS interface is defined as the A1p interface shown  
6 in Figure 2.2-2.

7 This standard fulfills the following criteria:

- 8 • supports current [1]~[6], [7] and [10] air interfaces;
- 9 • makes maximum use of existing standards from the TIA and other sources;
- 10 • promotes reliability enhancement, technical innovation, network product availability,  
11 and economic competition;
- 12 • allows connection of various manufacturers' BSs to the same MSC;
- 13 • supports future MSC and BS implementations;
- 14 • allows the separate evolution of MSC and BS technology.

15 The BS-MGW interface provides a bearer for traffic between a BS and an MGW. The BS  
16 and MGW interface, defined as the A2p interface (Reference Point 27), is shown in  
17 Figure 2.2-2.

18 The source BS - target BS interface provides for inter-BS soft/softer handoffs. It  
19 specifically represents the demarcation point between two BSs which coincides with the  
20 Reference Point "A<sub>ter</sub>". This point establishes the technical interface and designates the  
21 test points and operational division of responsibility between the source BS and target  
22 BS. The source BS and target BS interface is defined as the A3/A7 interface shown in  
23 Figure 2.2-1 and Figure 2.2-2.

24 The BS-PCF interface provides access between the BS and the Packet Control Function  
25 for high speed packet data services. It specifically represents the demarcation point  
26 between the BS and the PCF which coincides with the Reference Point "A<sub>quinter</sub>". This  
27 point establishes the technical interface and designates the test points and operational  
28 division of responsibility between the BS and the PCF. The BS-PCF interface is defined  
29 as the A8/A9 interface shown in Figure 2.2-1 and Figure 2.2-2.

30 The PCF-PDSN interface provides access between a Packet Control Function and a  
31 Packet Data Serving Node for high speed packet data services. It specifically represents  
32 the demarcation point between the PCF and the PDSN which coincides with the  
33 Reference Point "A<sub>quater</sub>". This point establishes the technical interface and designates  
34 the test points and operational division of responsibility between the PCF and the PDSN.  
35 The PCF-PDSN interface is defined as the A10/A11 interface shown in Figure 2.2-1 and  
36 Figure 2.2-2.

37 The PCF-PDSN interface definition fulfills the following criteria:

- 38 • allows connection of various manufacturers' PCFs to the same PDSN and vice versa;
- 39 • makes maximum use of existing standards from the Internet Engineering Task Force  
40 (IETF) and other sources;
- 41 • promotes quality of service and accounting information exchange between the PCFs  
42 and the PDSNs;
- 43 • promotes reliability enhancement, technical innovation, network product availability,  
44 and economic competition;

- supports future PCF and PDSN implementations;
- allows the separate evolution of PCF and PDSN technologies.

### 1.1.2 Scope

---

This standard provides the specification for the interfaces which coincide with the Reference Points “A”, “A<sub>ter</sub>”, “A<sub>quater</sub>”, and “A<sub>quinter</sub>” defined in the TR45 Network Reference Model shown in [18] and Reference Points 27 and 48 for Legacy MS Support [19].

The scope of this standard includes the following topics:

- MSC-BS and BS-BS interfaces:
  - descriptions of the specified functional capabilities that provide wireless telecommunications services across the MSC-BS and BS-BS interfaces as defined in the TR45 Network Reference Model;
  - descriptions of the specified functional capabilities that provide wireless telecommunications services across the MSCe-BS and the MGW-BS interfaces;
  - descriptions of the division of responsibility of the functions provided between the BS and the MSC, and between the source BS and the target BS, without prescribing specific implementations;
  - descriptions of the MSC-BS interface and the BS-BS interface standards that support DS-41 and cdma2000 systems.
- BS-PCF interfaces:
  - descriptions of the specified functional capabilities that provide packet data services across the BS-PCF interface;
  - descriptions of the division of responsibility of the functions provided between the BS and the PCF without prescribing specific implementations.
- PCF-PDSN interfaces:
  - descriptions of the specified functional capabilities that provide packet data services across the PCF-PDSN interface;
  - descriptions of the division of responsibility of the functions provided between the PCF and the PDSN without prescribing specific implementations.

The interfaces defined in this standard are specified by a set of characteristics, including:

- physical and electromagnetic parameters;
- channel structures;
- message types and contents;
- network operating procedures;
- user data framing and transport.

### 1.1.3 New Features and Enhancements in this Release

---

The following features have been added to this revision of the standard:

- A10 Flow Control
- Circuit Switched Video Conferencing Support (Service Options 57, 58)
- Direct Channel Assignment
- Mobile Equipment Identifier (MEID) Support
- Page Set Maintenance
- Remote Transcoder Operation (RTO)
- Reverse Packet Data Channel (R-PDCH) Support
- Support for Enhanced Frequency Hashing and Band Subclasses
- Support for cdma2000 Pre-Rev D MEID Capable Mobiles
- Transcoder Free Operation (TrFO)
- Vocoder Support
  - Wideband Speech Codec
- Voice Preference Over Packet (VPOP)

Enhancements have been made to the following features in this revision of the standard:

- PDSN Selection Algorithm
- Short Data Bursts

## 1.2 References

---

For consistency within IOS parts, the most commonly referenced documents [1]~[17] shall be the same as they appear here in this part, or left as “Reserved” if not used in a particular IOS part.

### 1.2.1 3GPP2 and TIA/EIA

---

- [1] 3GPP2 C.S0001-D v2.0, *Introduction to cdma2000 Standards for Spread Spectrum Systems*, September 2005.
- [2] 3GPP2 C.S0002-D v2.0, *Physical Layer Standard for cdma2000 Spread Spectrum Systems*, September 2005.
- [3] 3GPP2 C.S0003-D v2.0, *Medium Access Control (MAC) Standard for cdma2000 Spread Spectrum Systems*, September 2005.
- [4] 3GPP2 C.S0004-D v2.0, *Signaling Link Access Control (LAC) Standard for cdma2000 Spread Spectrum Systems*, September 2005.
- [5] 3GPP2 C.S0005-D v2.0, *Upper Layer (Layer 3) Signaling Standard for cdma2000 Spread Spectrum Systems*, September 2005.
- [6] 3GPP2 C.S0006-D v2.0, *Analog Signaling Standard for cdma2000 Spread Spectrum Systems*, September 2005.
- [7] 3GPP2 C.S0007-0, *Direct Spread Specification for Spread Spectrum Systems on ANSI-41 (DS-41) (Upper Layers Air Interface)*, June 2000.
- [8] 3GPP2 X.S0011-C, *Wireless IP Network Standard*, six parts, September 2003.

- 1 [9] 3GPP2 N.S0005, *Cellular Radiotelecommunications Intersystem Operations*,  
 2 December 1997.
- 3 [10] TIA/EIA-95-B, *Mobile Station - Base Station Compatibility Standard for*  
 4 *Wideband Spread Spectrum Cellular Systems*, March 1999.
- 5 [11] 3GPP2 A.S0011-C v2.0, *Interoperability Specification (IOS) for cdma2000*  
 6 *Access Network Interfaces – Part 1 Overview*, December 2005.
- 7 [12] 3GPP2 A.S0012-C v2.0, *Interoperability Specification (IOS) for cdma2000*  
 8 *Access Network Interfaces – Part 2 Transport*, December 2005.
- 9 [13] 3GPP2 A.S0013-C v2.0, *Interoperability Specification (IOS) for cdma2000*  
 10 *Access Network Interfaces – Part 3 Features*, December 2005.
- 11 [14] 3GPP2 A.S0014-C v2.0, *Interoperability Specification (IOS) for cdma2000*  
 12 *Access Network Interfaces – Part 4 (A1, A1p, A2, and A5 Interfaces)*, December  
 13 2005.
- 14 [15] 3GPP2 A.S0015-C v2.0, *Interoperability Specification (IOS) for cdma2000*  
 15 *Access Network Interfaces – Part 5 (A3 and A7 Interfaces)*, December 2005.
- 16 [16] 3GPP2 A.S0016-C v2.0, *Interoperability Specification (IOS) for cdma2000*  
 17 *Access Network Interfaces – Part 6 (A8 and A9 Interfaces)*, December 2005.
- 18 [17] 3GPP2 A.S0017-C v2.0, *Interoperability Specification (IOS) for cdma2000*  
 19 *Access Network Interfaces – Part 7 (A10 and A11 Interfaces)*, December 2005.
- 20 [18] 3GPP2 S.R0005-B, *Network Reference Model for cdma2000 Spread Spectrum*  
 21 *Systems*, April 2001.
- 22 [19] 3GPP2 X.S0012-0 v2.0, *Legacy MS Domain Step 1*, March 2004.
- 23

## 24 1.2.2 Other

---

- 25
- 26 [20] Internet Engineering Task Force, *RFC 2002 – IP Mobility Support Specification*,  
 27 1996.
- 28

## 29 1.3 Terminology

---

### 31 1.3.1 Acronyms

---

32 Acronym	Meaning
3GPP	Third Generation Partnership Project
3GPP2	Third Generation Partnership Project 2
ANSI	American National Standards Institute
BS	Base Station
BSC	Base Station Controller
BTS	Base Transceiver System
CDMA	Code Division Multiple Access
DS-41	Direct Spread (ANSI)-41
EHDM	Extended Handoff Direction Message
EIA	Electronics Industry Association
GHDM	General Handoff Direction Message

<b>Acronym</b>	<b>Meaning</b>
IETF	Internet Engineering Task Force
IOS	Interoperability Specification
IP	Internet Protocol
IS	Interim Standard
ISDN	Integrated Services Digital Network
IWF	Interworking Function
kbps	kilobits per second
MEID	Mobile Equipment Identifier
MGW	Media Gateway
MIP	Mobile Internet Protocol
MS	Mobile Station
MSC	Mobile Switching Center
MSCe	Mobile Switching Center Emulation
MTSO	Mobile Telephone Switching Office
PCF	Packet Control Function
PCM	Pulse Code Modulation
PDSN	Packet Data Serving Node
PSTN	Public Switched Telephone Network
RTO	Remote Transcoder Operation
SDU	Selection/Distribution Unit
TIA	Telecommunications Industry Association
TrFO	Transcoder Free Operation
TSB	Telecommunications Systems Bulletin
UDI	Unrestricted Digital Information
UMTS	Universal Mobile Telecommunication System
UHDM	Universal Handoff Direction Message
VPOP	Voice Preference Over Packet
XC	Transcoder

1

### 2 **1.3.2 Definitions**

---

3 **Base Station.** An entity in the public radio telecommunications system used for radio  
4 telecommunications with MSs.

5 **Base Station Controller.** The control portion of the BS that includes call control logic  
6 and interconnections to the MSC, the MSCe, the MGW, the PCF, the BTSs that are part  
7 of the BS, other BSCs, and BTSs of neighboring BSs for purposes of soft/softer handoff.

8 **Base Transceiver Station.** A component of a BS that includes radio equipment. A BTS  
9 is sometimes equated with the physical cell site of a wireless network.

10 **Bearer Connection.** A connection intended to provide a path for user traffic.

1 **Call Association.** The totality of the active communication between the MS and the  
2 network, including all signaling and transfer of user information.

3 **Cell.** The unit of a BS having the ability to radiate in a given geographic area. In this  
4 standard, a Cell ID refers to a particular cell and sector.

5 **Channel Assignment Message.** Either a Channel Assignment Message or Extended  
6 Channel Assignment Message.

7 **Circuit-Switched MSC.** A circuit-switched MSC provides processing, control and bear-  
8 er path for calls and services. The MSC provides signaling capability via an SS7-based  
9 connection to the BS on the A1 interface and bearer paths via terrestrial circuits on the  
10 A2 and A5 interfaces.

11 **DS-41.** An operational mode in which the BS and MS operate with the direct spread (DS)  
12 radio layers of the UMTS system defined by 3GPP, and the upper layers defined in  
13 [1]~[6] that conform to and interoperate with ANSI-41 based networks [9].

14 **Dormant Handoff.** A handoff that occurs when an MS with a dormant packet session  
15 determines that it has crossed a packet zone boundary. Dormant handoff results in A10  
16 connection(s) being established between the target PCF and the target PDSN. A dormant  
17 handoff may require exchange of higher layer protocol messages between the MS and the  
18 PDSN, and thus, reactivation of the packet data session. Note that no air interface  
19 channels are handed off or re-configured as the result of a dormant handoff.

20 **Fast Handoff.** Fast handoff is a particular type of hard handoff that applies only to  
21 packet data sessions. Fast handoff allows the target PDSN to connect to an anchor PDSN  
22 where the packet data session was first established, eliminating the need to re-establish a  
23 PPP session while the packet data session is active. Fast handoff allows for early  
24 establishment of the A10 connections on the target side.

25 **Handoff.** Handoff is the process by which an air interface circuit between an MS and a  
26 BS is transferred from the current BS equipment and air interface channel to either a  
27 different BS equipment and air interface channel or a different air interface channel on  
28 the current BS equipment. Handoffs are an IOS consideration insofar as user traffic and  
29 signaling paths through the RAN need to be established, modified or released;  
30 information needs to be exchanged between the source and target BSs; and air interface  
31 changes may need to be signaled to the core network. Refer also to [13], section 3.19, for  
32 specific handoff considerations. The following types of handoffs are supported:

- 33 1. **Hard Handoff:** A handoff characterized by a temporary disconnection of the Traffic  
34 Channel. Hard handoffs occur when the MS is transferred between disjoint Active  
35 Sets, when the CDMA Frequency Assignment changes, when the frame offset  
36 changes, or when the MS is directed from a CDMA Traffic Channel to an analog  
37 voice channel. From an IOS perspective, a change in Selection Distribution Unit  
38 (SDU) across BSs is considered to be a hard handoff.
- 39 2. **Soft Handoff:** A handoff occurring while the MS is in the Mobile Station Control on  
40 the Traffic Channel State. This handoff is characterized by commencing  
41 communications with a new BTS on the same CDMA Frequency Assignment  
42 without terminating communications with an old BTS. For IOS considerations, the  
43 same SDU function is used before and after the handoff is performed.
- 44 3. **Soft Handoff with Pre-Selection:** The configuration achieved when a BS internally  
45 splits a single forward flow of coded user information from the frame selector to  
46 send it to two or more cells controlled by that BS. In the reverse direction, the BS  
47 joins the flows of coded user information frames from those cells, selects the best

1 quality frame (preselection), and forwards only that selected frame to the frame  
2 selector.

3 4. **Softer Handoff**: A handoff involving two or more traffic channels on a call such that  
4 in the forward direction the BS splits a single flow of traffic channel frames into two  
5 or more forward flows to be sent to the MS with the power control combined bit set  
6 to indicate that the same reverse power control information is to be used. In the  
7 reverse direction the BS combines the traffic channel frames that are received from  
8 two or more cells/sectors and forms a single reverse flow from this combination.

9 **IMSI\_M**. MIN-based IMSI using the lower 10 digits to store the MIN.

10 **IMSI\_T**. True IMSI not associated with MIN. This could be 15 digits or fewer.

11 **Interworking Function**. The Interworking Function (IWF), used in the context of this  
12 standard, provides a translation of the user traffic on a circuit data call between the fixed  
13 network and the air interface.

14 **Logical Channel**. A logical path that can carry signaling, user traffic, or a combination  
15 of the two between two entities such as the network and the MS. A logical channel can be  
16 instantiated over one or more physical channels. Logical channels may also share  
17 physical channels.

18 **MC-41**. An operational mode in which the BS and MS operate with the multi-carrier  
19 (MC) radio layers and the upper layers defined in [1]~[6] that conform to and inter-  
20 operate with ANSI-41 based networks [9].

21 **Media Gateway**. The MGW provides an interface between the packet environment of  
22 the core network and the circuit switched environment of the Public Switched Telephone  
23 Network (PSTN) for bearer traffic, when equipped with circuit capabilities. The MGW  
24 may provide transcoding functions to the bearer traffic. The MGW may also provide  
25 modem functions to convert digital byte streams to and from audio modem tones placed  
26 on circuits. It also provides policy enforcement relative to its activities and resources. The  
27 MGW provides a bearer path to the BS. The MSCe controls the MGW.

28 **Mobile Equipment Identifier (MEID)**. A 56-bit number assigned by the MS manu-  
29 facturer, uniquely identifying the MS equipment.

30 **Mobile Station**. An entity in the public cellular radio telecommunications service  
31 intended to be used while in motion or during halts at unspecified points. Mobile stations  
32 include portable units (e.g., hand-held personal units) and units installed in vehicles.

33 **Mobile Switching Center**. The MSC switches MS-originated or MS-terminated traffic.  
34 An MSC connects to one or more BS . It may connect to other public networks (PSTN,  
35 ISDN, etc.), other MSCs in the same network, or MSCs in different networks. (It has  
36 been referred to as Mobile Telephone Switching Office, MTSO.) It provides the interface  
37 for user traffic between the wireless network and other public switched networks, or other  
38 MSCs.

39 In this document, for signaling, the term MSC refers to either a circuit-switched MSC or  
40 an MSCe. For bearer path, the term MSC refers to either a circuit-switched MSC or a  
41 MGW. In situations where a statement applies to either the circuit-switched or packet-  
42 based MSC exclusively, the type of MSC will be specifically identified (i.e. "circuit-  
43 switched MSC" or "MSCe").

1           **Mobile Switching Center Emulation.** The MSCe provides processing and control for  
 2 calls and services. The MSCe provides signaling capabilities equivalent to a circuit-  
 3 switched MSC on the A1p interface. The MSCe connects to a BS via IP based protocols.

4           **origination message.** In this document, “origination message” is used to indicate either  
 5 an Origination or Enhanced Origination air interface message.

6           **ORYX.** A wireless data encryption and decryption algorithm.

7           **Packet Control Function.** An entity in the radio access network that manages the relay  
 8 of packets between the BS and the PDSN.

9           **Packet Data Session.** The set of one or more packet data service instances in use at any  
 10 time at the RAN/PDSN. A packet data session starts when the first service instance  
 11 transitions out of the Null/Inactive State, and ends when the last service instance  
 12 transitions to the Null/Inactive State.

13           **Packet Data Serving Node.** An entity that routes MS originated or MS terminated  
 14 packet data traffic. A PDSN establishes, maintains and terminates link layer sessions to  
 15 MSs.

16           **Physical Channel.** A physical path between the SDU function and the MS that consists  
 17 of any connecting A3 traffic channel(s) and radio channel(s). Depending on the radio  
 18 technology in use, a physical channel may be in soft handoff between the MS and the  
 19 SDU function.

20           **Remote Transcoder Operation:** A network capability for endpoints with incompatible  
 21 codecs. RTO attempts to enable the bearer by matching the incompatible codecs with a  
 22 single transcoder. For circumstances where a single transcoder is not available to enable  
 23 the bearer, two tandem transcoders may be required to find a match between the end-  
 24 points.

25           **SDU Function.** The SDU function (Selection/Distribution Unit function) provides bearer  
 26 termination within the BS. An example SDU implementation may include the following  
 27 functions:

- 28           • Signaling Layer 2: This function performs the layer 2 functionality of the air  
 29 interface signaling protocol and is responsible for the reliable delivery of layer 3  
 30 signaling messages between the BS and the MS. This functionality may be in the  
 31 BTS in some situations.
- 32           • Multiplex Sublayer: This function multiplexes and demultiplexes user traffic and  
 33 signaling traffic for the air interface.
- 34           • Power Control: This function administers parts of the forward and reverse link power  
 35 control in a CDMA system. This function and the channel elements provide power  
 36 control functionality. This function generates or utilizes the power control  
 37 information in whole or in part that is exchanged over the air interface or with the  
 38 channel elements.
- 39           • Frame Selection/Distribution: This function is responsible for selecting the “best”  
 40 incoming air interface reverse link frame from the channel elements involved in the  
 41 soft handoff. It also distributes forward air interface frames to all channel elements  
 42 involved in a call.
- 43           • Backhaul Frame Handler: This function demultiplexes the control information and  
 44 the air interface reverse frame from the frame received over the backhaul network. It

1 also multiplexes the control information and the air interface frames in the forward  
2 direction.

3 • **Intra-BS Frame Handler:** This function exchanges backhaul frames with channel  
4 elements involved in intra-BS soft handoff.

5 • **Inter-BS Frame Handler:** This function exchanges backhaul frames with channel ele-  
6 ments involved in inter-BS soft handoff.

7 **Sector.** A face of a of physical radio equipment implementation.

8 **Service Instance.** An instance of a higher level communication service between the MS  
9 user and various other endpoints.

10 **Service Provider Network.** A network operated by either the home service provider or  
11 the visited service provider. The home service provider maintains the customer business  
12 relationship with the user. The visited service provider provides access services through  
13 the establishment of a service agreement with the home service provider.

14 **Serving Network.** The network that provides access services to the user.

15 **Signaling Connection.** A connection intended to provide a path for signaling traffic.

16 **Source Base Station.** The BS that is in control of the call.

17 **System Identification.** The System Identification (SID) is a number that uniquely ident-  
18 ifies a network within a cellular or PCS system.

19 **Target Base Station.** Any BS that supports the call other than the source BS.

20 **Transcoder.** A function that converts from one speech encoding format to another  
21 speech encoding format.

22 **Transcoder Free Operation:** A network capability for MS-to-MS calls, where the MSs  
23 have identical codecs. TrFO enables the bearer path without introducing vocoders in the  
24 bearer path. Compressed speech is passed between the MS endpoints.

## 25 1.4 Organization

---

26 This section outlines the relationship of the current specification with neighboring  
27 elements (air interface, packet data network and the core network) as well as with older  
28 versions of the IOS itself. The cross reference of IOS specifications in section 1.4.1 is  
29 provided for information and is not intended to indicate additional requirements for the  
30 IOS.

### 31 1.4.1 Overall IOS Specifications

---

32 When addressing previous revisions of the IOS, this revision of the specification uses a  
33 common (historical) identifier, IOS v x.y.z, which can be cross referenced as shown in  
34 Table 1.4.1-1.

35

**Table 1.4.1-1 IOS Cross References**

<b>Common<sup>2</sup></b>	<b>CDG</b>	<b>3GPP2</b>	<b>TIA</b>	<b>Air Interface<sup>3</sup></b>
-	-	-	IS-634 December 1995	IS-95 July 1993
-	-	-	IS-634-A July 1998	IS-95-A May 1995
-	-	-	IS-634-B April 1999	TIA/EIA-95-B March 1999
IOS v2.0.1	IOS v2.0.1 Dec 1998	-	-	-
IOS v2.2	IOS v2.2 June 1999	-	-	-
IOS v2.3	IOS v2.3 Feb 2000	-	-	-
IOS v2.4	IOS v2.4 March 2000	-	-	-
IOS v3.0	IOS v3.0 Nov 1998	-	-	-
IOS v3.1.1	IOS v3.1.1 Aug 1999	-	-	-
IOS v3.2	IOS v3.2 March 2001	-	-	-
IOS v4.0	-	A.S0001 v0.1 June 2000	IS-2001 December 2000	IS-2000 August 2001
IOS v4.1	-	A.S0001-A v2.0 June 2001	IS-2001-A August 2001	IS-2000-A April 2002
IOS v4.2	-	A.S0011~17 v2.0 May 2002	TIA-2001-B May 2002	TIA-2000-B May 2002
IOS v4.3	-	A.S0011~17-A v2.0.1 July 2003	TIA-2001-C July 2003	TIA-2000-B May 2002
IOS v4.3.1	-	A.S0011~17-B v1.0 April 2004	TIA-2001-C-1 December 2003	TIA-2000-C May 2002
IOS v5.0	-	A.S0011~17-C v1.0 February 2005	TIA-2001-D February 2005	TIA-2000-D March 2004
IOS v5.0.1	-	A.S0011~17-C v2.0 December 2005	TIA-2001-D-1 tbd	TIA-2000-D-1 September 2005

1

## 1.5 Document Layout

2

3

The IOS is organized into seven parts, each published in a separate document:

4

[11] Overview, general overview

5

[12] Transport, protocol definitions and transport requirements

6

[13] Features, descriptions of features

<sup>2</sup> The Common identifier aligns with numbering used in the Software Version Information Element.

<sup>3</sup> The relationship between air interface and IOS releases is provided for information and is not intended to be an absolute indication of features supported by an IOS release.

1 [14] A1/A1p/A2/A5 Interfaces, definition of the interfaces

2 [15] A3/A7 Interfaces, definition of the interfaces

3 [16] A8/A9 Interfaces, definition of the interfaces

4 [17] A10/A11 Interfaces, definition of the interfaces

5 The interface documents define the individual interfaces – this includes message proced-  
6 ures, message bitmaps, information element definitions, and the definitions of timers that  
7 are related to the interface. Note that some information elements are used on multiple  
8 interfaces; in this situation, the information element is defined in each of the associated  
9 interface documents. Changes to the definition of an information element in one interface  
10 document do not imply changes to its definition in other interface documents. However,  
11 insofar as possible, the same Information Element Identifier shall be used in all definiti-  
12 ons of the same information element.

13 The Features document provides descriptions of the features supported in the IOS and  
14 Stage 2 text (e.g. call flows) for these features, which interfaces are used, which messages  
15 are used, and how the feature is implemented using these messages.

## 16 1.6 Documentation Conventions

---

17 “Shall” and “shall not” identify requirements to be followed strictly to conform to the  
18 standard and from which no deviation is permitted. “Should” and “should not” indicate  
19 that one of several possibilities is recommended as particularly suitable, without  
20 mentioning or excluding others; that a certain course of action is preferred but not  
21 necessarily required; or (in the negative form) that a certain possibility or course of action  
22 is discouraged but not prohibited. “May” and “need not” indicate a course of action  
23 permissible within the limits of the standard. “Can” and “cannot” are used for statements  
24 of possibility and capability, whether material, physical, or causal.

25 The scenarios and examples in this specification are not meant to be exhaustive, but are  
26 only used to help explain some of the important procedures of the protocol.

27 Figure 1.6-1 is provided as an example of the call flow conventions used in this specifi-  
28 cation.

29 Several points within the diagram are worthy of note. The circled numbers in the  
30 following figure correspond to the numbered items below.

- 31 1. Horizontal dotted lines are used to indicate messaging that is not part of defined  
32 interfaces specified in this specification. Not all air interface messages are shown,  
33 and names may be generic. For example, the phrase “handoff direction message” is  
34 meant to include Extended Handoff Direction Message (EHDM), General Handoff  
35 Direction Message (GHDM), and Universal Handoff Direction Message (UHDM).
- 36 2. Vertical dotted lines between messages are used to indicate the span of timers. The  
37 timer name is placed as close as possible to the line. Timer names begin with a  
38 capital “T” followed by digits or alphabetic characters. If a timer expires prior to  
39 reception of a message that stops the timer, the expiration is shown with an ‘x’ at the  
40 end of the vertical dotted line.
- 41 3. Horizontal solid lines are used to indicate messaging that is part of the interfaces  
42 specified in this standard.
- 43 4. Lower case letters are associated with individual messaging instances in the diagram  
44 in alphabetical order arranged vertically. These letters correlate the text below the  
45 diagram with portions of the diagram.

- 1                   5. Procedures that may involve the exchange of several messages are shown as an open  
2                   block arrow with the name of the procedure inside.
- 3                   6. Comments related to parts of the diagram are located in a comment column on the  
4                   right side of the diagram.

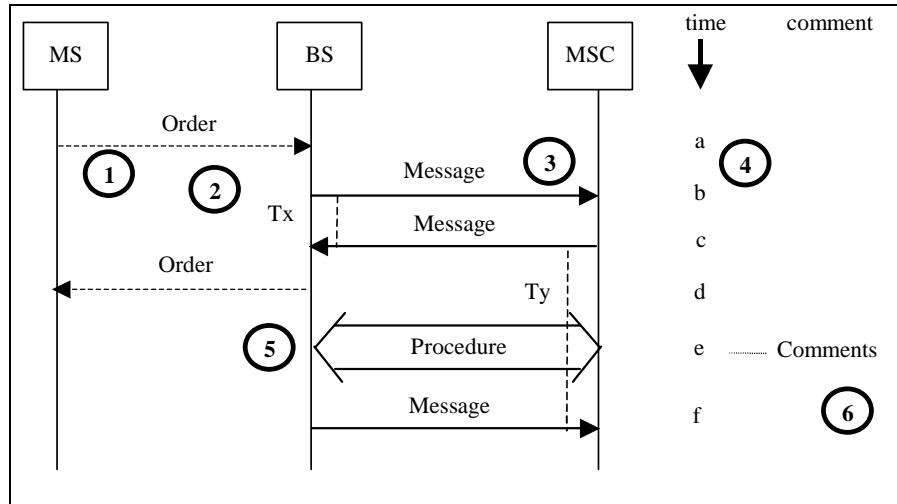

5  
6 **Figure 1.6-1 Document Convention Example: Call Clear Initiated by MS**

- 7                   a. The MS transmits an Order over the reverse link.
- 8                   b. The BS sends a message to the MSC. The BS starts timer  $T_x$ .
- 9                   c. The MSC sends a message to the BS and starts timer  $T_y$ . The BS stops timer  $T_x$ .
- 10                  d. The BS acknowledges the MS message by returning an Order over the forward link.
- 11                  e. The BS and MSC execute the procedure.
- 12                  f. The BS returns a message to the MSC. The MSC stops timer  $T_y$ .

## 13 **1.6.1 Procedural Descriptions**

14                  The procedural descriptions are broken into sections where each section describes one of  
15                  the messages in the procedure. The description for each procedure is written to flow  
16                  through each section devoted to the messages that make up the procedure. Each of these  
17                  sections has the following subsection breakdowns (as appropriate):

- 18                  1. **Successful Operation:** this section is used to describe what the message is for, why  
19                  the sender is sending it, and what the receiver is expected to do with the message. It  
20                  may also provide a brief tutorial on the overall impact of this message regarding the  
21                  particular procedure. It includes invocation of any pertinent timers or discussion of  
22                  timing constraints. It may also provide subsections that describe the uses of the  
23                  elements within the message, particularly if they are not obvious.
- 24                  2. **Failure Operation:** if applicable, this section is used to describe the actions of the  
25                  sender if the expected response is not received by the sender. This includes treatment  
26                  of timer expiration or receipt of failure messages stemming from the message that  
27                  was sent.
- 28                  3. **Abnormal Operation:** if applicable, this section is used to describe out of sequence  
29                  events that could possibly occur and the treatment by the receiver of the message.
- 30
- 31

1

(This page intentionally left blank)

2

## 2.0 Interface Model

---

The logical reference model used for this standard is the Network Reference Model as shown in [18] and [19].

### 2.1 Reference Points A, A<sub>ter</sub>, A<sub>quinter</sub>, A<sub>quater</sub>, 48 and 27

---

The Network Reference Model contains reference points A, A<sub>ter</sub>, A<sub>quinter</sub>, A<sub>quater</sub>, 48 and 27 that are implemented by the protocols and interfaces of this standard.

- The A reference point is implemented by the A1, A2 and A5 interfaces.
- Reference point 48 is implemented by the A1p interface.
- Reference point 27 is implemented by the A2p interface.
- The A<sub>ter</sub> reference point is implemented by the A3 and A7 interfaces.
- The A<sub>quater</sub> reference point is implemented by the A10 and A11 interfaces.
- The A<sub>quinter</sub> reference point is implemented by the A8 and A9 interfaces.

### 2.2 Interface Reference Model

---

The interfaces defined in this standard are described below.

A1	The A1 interface carries signaling information between the call control and mobility management functions of the circuit-switched MSC and the call control component of the BS (BSC).
A1p	The A1p interface carries signaling information between the call control and mobility management functions of the MSCe and the call control component of the BS (BSC).
A2	The A2 interface is used to provide a path for user traffic. The A2 interface carries 64/56 kbps PCM information (for circuit-oriented voice) or 64 kbps Unrestricted Digital Information (UDI, for ISDN) between the Switch component of the circuit-switched MSC and the Selection/Distribution Unit (SDU) function of the BS.
A2p	The A2p interface provides a path for packet-based user traffic sessions. The A2p interface carries either compressed (i.e., vocoded) or uncompressed (i.e., PCM) voice information via IP packets between the MGW and either the Transcoder (XC) or the Selection/Distribution Unit (SDU) function of the BS.
A3	The A3 interface is used to transport user traffic and signaling for inter-BS soft/softer handoff when a target BS is attached to the frame selection function within the source BS. The A3 interface carries coded user information (voice/data) and signaling information between the source BS SDU function and the channel element component (BTS) of the target BS. This is a logical description of the endpoints of the A3 interface. The physical endpoints are beyond the scope of this specification. The A3 interface is composed of two parts: signaling and user traffic. The signaling information is carried across a separate logical channel from the user traffic channel, and controls the allocation and use of channels for transporting user traffic.
A5	The A5 interface is used to provide a path for user traffic for circuit-oriented data calls between the source BS and the circuit-switched MSC.



1

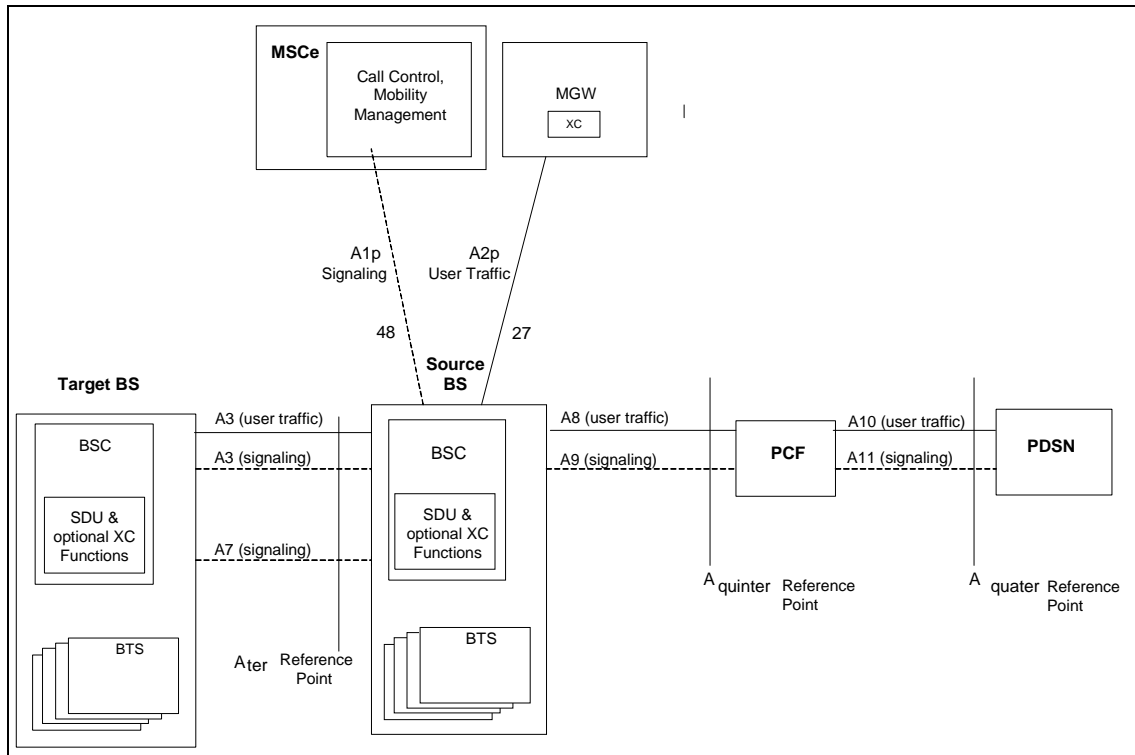

2

3

**Figure 2.2-2 Reference Model for Packet-based cdma2000 Access Network Interfaces**

4

5

6

1

(This page intentionally left blank)

2

## 3.0 Information Flows

---

The interfaces defined in this standard provide:

- bearer (user traffic) connections (A2, A2p, A3 (traffic), A5, A8, and A10);
- a signaling connection between the channel element component of the target BS and the SDU function in the source BS (A3 signaling);
- a direct BS to BS signaling connection (A7);
- a signaling connection between the BS and the circuit-switched MSC (A1);
- a signaling connection between the BS and the MSCe (A1p);
- a signaling connection between the BS and PCF (A9); and
- a signaling connection between a PCF and PDSN pair (A11). A11 signaling messages are also used for passing accounting related and other information from the PCF to the PDSN.

In general, the functions specified on the interfaces are based on the premise that the interfaces carry signaling information that traverses the following logical paths:

- between the BS and MSC only (e.g., BS management information);
- between the MS and the MSC via the BS (e.g., the BS maps air interface messages to the A1 or A1p interface);
- between the BS and other network elements via the MSC;
- between the source BS and the target BS;
- between the BS and the PCF;
- between the PCF and the PDSN; and
- between the MS and the PDSN (e.g., authorization information and Mobile Internet Protocol (MIP) signaling).

These logical paths define all of the traffic that can exist on the defined interfaces.

1

(This page intentionally left blank)

2

3

## 4.0 MS Mobility for Packet Data Service

The Figure 4-1 provides a conceptual view of levels of packet data mobility.

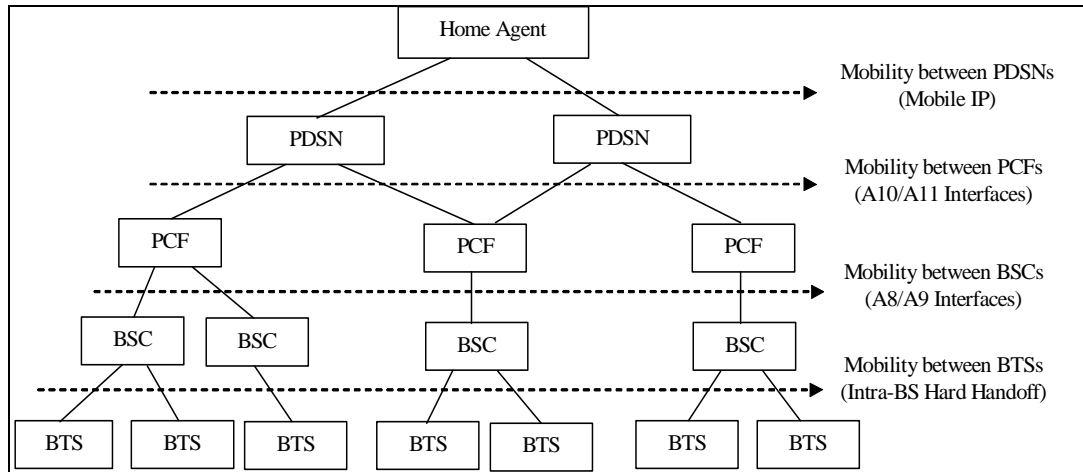

**Figure 4-1 Levels of Packet Data Mobility**

- MIP [20] supports MS mobility between PDSNs under the same Home Agent. The PDSN provides the functionality of the Foreign Agent.
- The A10/A11 interfaces support MS mobility between PCFs under the same PDSN.
- The A8/A9 interfaces support MS mobility between BSCs under the same PCF.
- Hard handoff, fast handoff, dormant handoff and soft handoff procedures realize MS mobility between BTSs.

1

(This page intentionally left blank)

2

3