

3GPP2 A.R1001-B v1.0

September 2010



3RD GENERATION
PARTNERSHIP
PROJECT 2
"3GPP2"

3GPP2 TSG-A Numbering Reference

© 2010, 3GPP2

3GPP2 and its Organizational Partners claim copyright in this document and individual Organizational Partners may copyright and issue documents or standards publications in individual Organizational Partner's name based on this document. Requests for reproduction of this document should be directed to the 3GPP2 Secretariat at secretariat@3gpp2.org. Requests to reproduce individual Organizational Partner's documents should be directed to that Organizational Partner. See www.3gpp2.org for more information.

Revision History

Date	Revision	Description
February 2007	A.R1001-0 v1.0	Publication.
April 2009	A.R1001-A v1.0	Incorporates assignments from IOS v5.1, HRPD IOS-B v2.0, HRPD IOS-C v2.0, BCMCS IOS-A v2.0 and A.S0022-0 v1.0.
September 2010	A.R1001-B v1.0	Incorporate assignments from A.S0011~17-D v2.0, A.S0008/9-C v3.0, A.S0022-0 v2.0 and A.S00024-0 v1.0.

Table of Contents

1	Table of Contents		
2			
3	Foreword.....	iv	
4	1 Introduction.....	1-1	
5	1.1 Overview.....	1-1	
6	1.1.1 Purpose.....	1-1	
7	1.1.2 Scope.....	1-1	
8	1.1.3 Document Convention.....	1-1	
9	1.2 References.....	1-1	
10	1.2.1 Informative References.....	1-1	
11	1.3 Terminology.....	1-2	
12	1.3.1 Acronyms.....	1-2	
13	1.3.2 Definitions.....	1-3	
14	1.4 Interaction Between Specifications.....	1-3	
15	2 GRE Attributes.....	2-1	
16	3 Message Types.....	3-1	
17	3.1 A1/A1p Interface.....	3-1	
18	3.2 A3/A7 Interface.....	3-10	
19	3.3 A9 Interface.....	3-10	
20	3.4 A11 Interface.....	3-15	
21	3.5 A13 Interface.....	3-17	
22	3.6 A14 Interface.....	3-21	
23	3.7 A15 Interface.....	3-21	
24	3.8 A16 Interface.....	3-21	
25	3.9 A17, A18, and A19 Interface.....	3-25	
26	3.10 A21 Interface.....	3-36	
27	3.11 A23 Interface.....	3-39	
28	4 Information Element Identifiers.....	4-1	
29	4.1 A1 IEs.....	4-1	
30	4.2 A3/A7 IEs.....	4-14	
31	4.3 A9 IEs.....	4-14	
32	4.4 A11 IEs.....	4-23	
33	4.5 A13 IEs.....	4-25	
34	4.6 A14 IEs.....	4-33	
35	4.7 A15 IEs.....	4-39	
36	4.8 A16 IEs.....	4-39	
37	4.9 A17, A18 and A19 IEs.....	4-50	

1	4.10	A21 IEIs	4-60
2	4.11	A23 IEIs	4-64
3	5	Code, Cause, and Other Values	5-1
4	5.1	A1 Cause Values.....	5-1
5	5.2	A3/A7 Cause Values.....	5-8
6	5.3	A9 Cause Values and Indicators	5-8
7	5.4	A11 Code, PDSN Code, and Status Values	5-17
8	5.5	A13 Cause Values.....	5-30
9	5.6	A14 Cause Values.....	5-32
10	5.7	A15 Code and Cause Values.....	5-32
11	5.8	A16 Cause Values.....	5-32
12	5.9	A17 Cause Values.....	5-34
13	5.10	A21 Cause, Event and GCSNA Status Values	5-37
14	5.11	A23 Code and Cause Values.....	5-42
15			

Table of Figures

1
2
3
4
5
6
7

Figure 1.4-1 Architecture Interaction Reference Model (SC/MM in the AN)..... 1-3
Figure 1.4-2 Architecture Interaction Reference Model (SC/MM in the PCF) 1-4

Table of Tables

1		
2		
3	Table 2-1	GRE Attributes2-1
4	Table 3-1	Cross Reference Between Specifications and Interfaces Used..... 3-1
5	Table 3.1-1	A1 (BSMAP) Message Types 3-1
6	Table 3.1-2	A1 (DTAP) Message Types 3-7
7	Table 3.3-1	A9 Message Types..... 3-10
8	Table 3.4-1	A11 Message Types..... 3-15
9	Table 3.5-1	A13 Message Types..... 3-17
10	Table 3.8-1	A16 Message Types..... 3-21
11	Table 3.9-1	A17, A18, and A19 Message Types 3-25
12	Table 3.10-1	A21 Message Types..... 3-36
13	Table 4.1-1	A1 IEIs..... 4-1
14	Table 4.3-1	A9 IEIs..... 4-14
15	Table 4.4-1	A11 IEIs..... 4-23
16	Table 4.5-1	A13 IEIs..... 4-25
17	Table 4.6-1	A14 IEIs..... 4-33
18	Table 4.8-1	A16 IEIs..... 4-39
19	Table 4.9-1	A17 IEIs..... 4-50
20	Table 4.10-1	A21 IEIs..... 4-60
21	Table 5.1-1	A1 Cause Values 5-1
22	Table 5.3-1	A9 Cause Values 5-8
23	Table 5.3-2	A9 Indicators 5-16
24	Table 5.4-1	A11 Code Values..... 5-17
25	Table 5.4-2	A11 Status Values 5-21
26	Table 5.4-3	A11 NVSE Application Types 5-24
27	Table 5.4-4	A11 PDSN Code Values..... 5-28
28	Table 5.5-1	A13 Cause Values 5-30
29	Table 5.8-1	A16 Session Transfer Abort Cause Values 5-32
30	Table 5.8-2	A16 Session Transfer Reject Cause Values..... 5-33
31	Table 5.9-1	A17 Cause Values 5-35
32	Table 5.10-1	A21 Cause Values 5-37
33	Table 5.10-2	A21 Event Values..... 5-39
34	Table 5.10-3	GCSNA Status Values..... 5-41
35		
36		

1 **Foreword**

2 This foreword is not part of this document.

3 The Radio Access Network (RAN) identifiers listed in this document are provided for guidance in the
4 development of interface messaging where interfaces are shared between 3GPP2 TSG-A specifications.

5

1
2
3
4
5

(This page intentionally left blank)

1 Introduction

1.1 Overview

This informative document includes a listing of 1x, High Rate Packet Data (HRPD), Broadcast Multicast Service (BCMCS), and Femtocell Interoperability Specification (IOS) identifiers.

1.1.1 Purpose

The purpose of this document is to provide a single point of reference for listing RAN identifiers (e.g., message types and Information Element Identifiers (IEIs)). TSG-A maintains and routinely updates this document to prevent duplicate number assignment.

1.1.2 Scope

This document provides, for information, a list of 1x, HRPD, BCMCS IOS, and Femtocell identifiers used in RAN specifications within 3GPP2 TSG-A. In the event that the identifiers in this report do not align with those in a published specification, the identifiers in the published specification take precedence.

1.1.3 Document Convention

“Shall” and “shall not” identify requirements to be followed strictly to conform to the standard and from which no deviation is permitted. “Should” and “should not” indicate that one of several possibilities is recommended as particularly suitable, without mentioning or excluding others; that a certain course of action is preferred but not necessarily required; or (in the negative form) that a certain possibility or course of action is discouraged but not prohibited. “May” and “need not” indicate a course of action permissible within the limits of the standard. “Can” and “cannot” are used for statements of possibility and capability, whether material, physical, or causal.

1.2 References

References are either normative or informative. A normative reference is used to include another document as a mandatory part of a 3rd Generation Partnership Project 2 (3GPP2) specification. Documents that provide additional non-essential information are included in the informative references section.

1.2.1 Informative References

- [1] **3GPP2:** A.S0008-B v2.0, *Interoperability Specification (IOS) for High Rate Packet Data (HRPD) Radio Access Network Interfaces with Session Control in the Access Network*, December 2008.
- [2] **3GPP2:** A.S0008-C v3.0, *Interoperability Specification (IOS) for High Rate Packet Data (HRPD) Radio Access Network Interfaces with Session Control in the Access Network*, June 2010.
- [3] **3GPP2:** A.S0009-B v2.0, *Interoperability Specification (IOS) for High Rate Packet Data (HRPD) Radio Access Network Interfaces with Session Control in the Packet Control Function*, December 2008.
- [4] **3GPP2:** A.S0009-C v3.0, *Interoperability Specification (IOS) for High Rate Packet Data (HRPD) Radio Access Network Interfaces with Session Control in the Packet Control Function*, June 2010.

- 1 [5] **3GPP2:** A.S0011-D v2.0, *Interoperability Specification (IOS) for cdma2000 Access Network*
2 *Interfaces – Part 1 Overview*, August 2009.
- 3 [6] **3GPP2:** A.S0012-D v2.0, *Interoperability Specification (IOS) for cdma2000 Access Network*
4 *Interfaces – Part 2 Transport*, August 2009.
- 5 [7] **3GPP2:** A.S0013-D v2.0, *Interoperability Specification (IOS) for cdma2000 Access Network*
6 *Interfaces – Part 3 Features*, August 2009.
- 7 [8] **3GPP2:** A.S0014-D v2.0, *Interoperability Specification (IOS) for cdma2000 Access Network*
8 *Interfaces – Part 4 (A1, A1p, A2, and A5 Interfaces)*, August 2009.
- 9 [9] **3GPP2:** A.S0015-D v2.0, *Interoperability Specification (IOS) for cdma2000 Access Network*
10 *Interfaces – Part 5 (A3 and A7 Interfaces)*, August 2009.
- 11 [10] **3GPP2:** A.S0016-D v2.0, *Interoperability Specification (IOS) for cdma2000 Access Network*
12 *Interfaces – Part 6 (A8 and A9 Interfaces)*, August 2009.
- 13 [11] **3GPP2:** A.S0017-D v2.0, *Interoperability Specification (IOS) for cdma2000 Access Network*
14 *Interfaces – Part 7 (A10 and A11 Interfaces)*, August 2009.
- 15 [12] **3GPP2:** A.S0019-A v2.0, *Interoperability Specification (IOS) for Broadcast Multicast Services*
16 *(BCMCS)*, April 2008.
- 17 [13] **3GPP2:** A.S0022-0 v2.0, *Interoperability Specification (IOS) for Evolved High Rate Packet*
18 *Data (eHRPD) Radio Access Network Interfaces and Interworking with Enhanced Universal*
19 *Terrestrial Radio Access Network (E-UTRAN)*, April 2010.
- 20 [14] **3GPP2:** A.S0023-0 v1.0, *Interoperability Specification (IOS) for High Rate Packet Data*
21 *(HRPD) Radio Access Network Interfaces and Interworking with World Interoperability for*
22 *Microwave Access (WiMAX)*, April 2009.
- 23 [15] **3GPP2:** A.S0024-0 v1.0, *Interoperability Specification (IOS) for Femtocell Access Points*,
24 March 2010.

26 1.3 Terminology

28 1.3.1 Acronyms

AN	Access Network
AN-AAA	Access Network – Authentication, Authorization, Accounting
AT	Access Terminal
BCMCS	Broadcast Multicast Services
BS	Base Station
BSMAP	Base Station Management Application Part
DTAP	Direct Transfer Application Part
eHRPD	evolved High Rate Packet Data
GCSNA	Generic Circuit Services Notification Application
GRE	Generic Routing Encapsulation
HRPD	High Rate Packet Data
HSGW	HRPD Serving Gateway
IEI	Information Element Identifier

IOS	Interoperability Specification
IWS	Interworking Solution
LAC	Link Access Control
MS	Mobile Station
MSC	Mobile Switching Center
MSCe	Mobile Switching Center Emulation
NVSE	Normal Vendor/Organization Specific Extension
PCF	Packet Control Function
PDSN	Packet Data Serving Node
PDU	Packet Data Unit
RAN	Radio Access Network
RT	Radio Transceiver
SC/MM	Session Control / Mobility Management
UATI	Unicast Access Terminal Identifier
WiMAX	World Interoperability for Microwave Access

1

2 **1.3.2 Definitions**

3

4 HRPD For purposes of this document, the term ‘HRPD’ refers to either a legacy HRPD
 5 or an evolved HRPD (eHRPD) system and the listed references are used to
 6 provide additional differentiation.

7 **1.4 Interaction Between Specifications**

8 HRPD IOS [1], [2], [3], [4] and BCMCS IOS [12] refer to the 1x IOS [5]~[11] for common sections and
 9 employ revision marks or references to identify relevant changes to the 1x IOS. As some interface
 10 message types, IELs and cause codes are shared between specifications, the intent of this report is to list
 11 the unique RAN identifiers in one document to prevent their accidental reuse between 1x and HRPD
 12 common interfaces, as shown in Figure 1.4-1 and Figure 1.4-2.

13

14 Note: In the section 1.4 figures, the A23 interface between the source AN and the World Interoperability
 15 for Microwave Access (WiMAX^{TM1}) Signal Forwarding Function is not shown for clarity.

16

1 ¹ “WiMAX Forum,” the WiMAX Forum logo and the WiMAX Forum Certified logo are registered trademarks of the WiMAX Forum. “WiMAX,” “Mobile WiMAX,” “Fixed WiMAX,” “WiMAX Certified,” and “WiMAX Forum Certified” are trademarks of the WiMAX Forum.

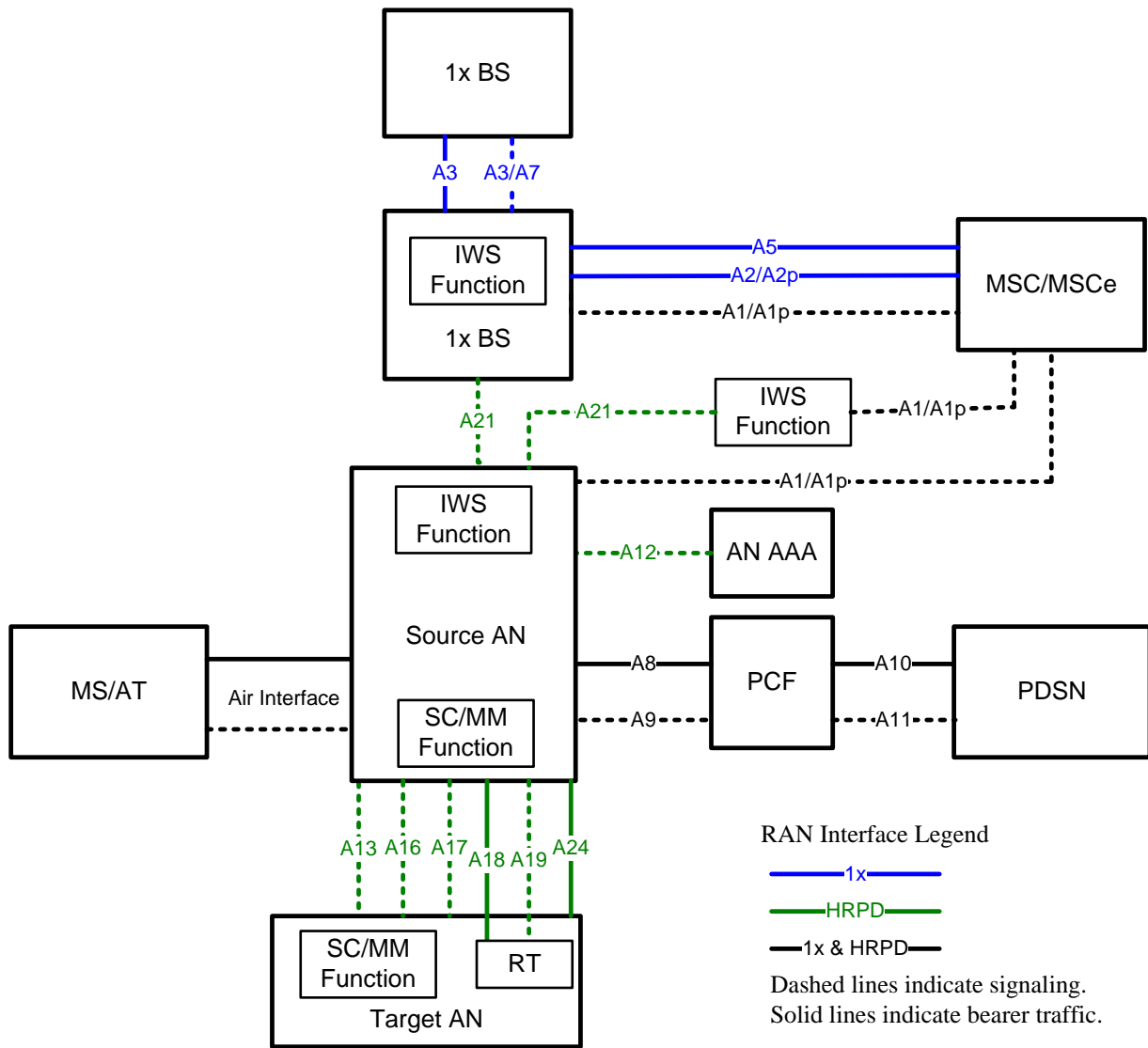

1
2

Figure 1.4-1 Architecture Interaction Reference Model (SC/MM in the AN)

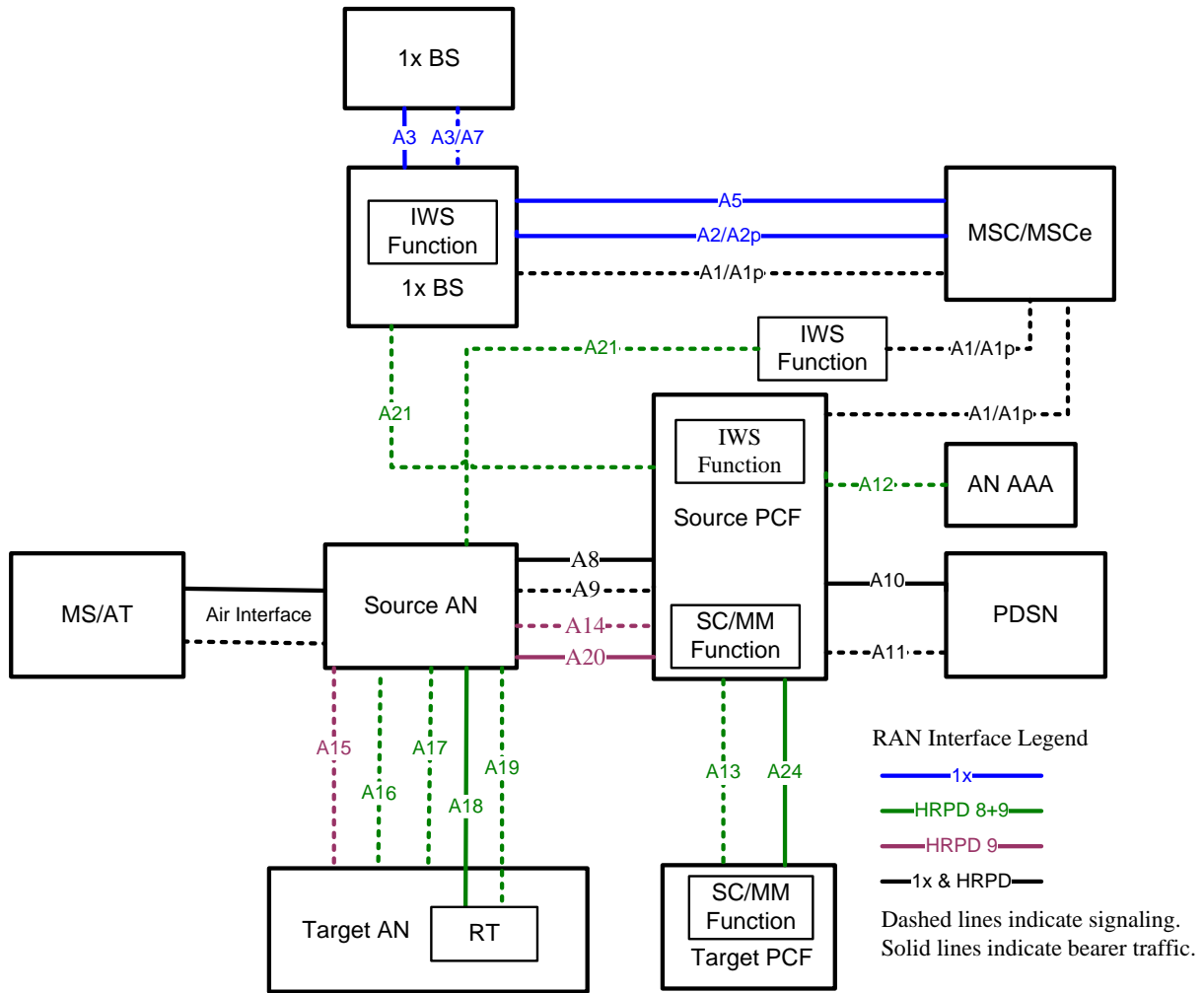

Figure 1.4-2 Architecture Interaction Reference Model (SC/MM in the PCF)

1
2
3
4
5

1
2
3
4

(This page intentionally left blank)

2 GRE Attributes

This section lists the Generic Routing Encapsulation (GRE) Attributes used in RAN specifications, per interface.

Table 2-1 GRE Attributes

Type	Attribute Name	Reference
01H	Short Data Indicator	[6]
02H	Flow Control Indicator	[6]
03H	IP Flow Discriminator	[1], [2], [3], [4], [6]
04H	Segmentation Indication	[1], [2], [3], [4], [6], [12]
05H	Buffered Data Information	[2], [4]

1
2
3
4

(This page intentionally left blank)

3 Message Types

This section lists the message types used in RAN specifications, per interface.

Table 3-1 Cross Reference Between Specifications and Interfaces Used

Specification	Interface Messaging Used
1x IOS [5]~[11]	A1/A1p, A3/A7, A9, A11
HRPD IOS with SC/MM in the AN [1], [2], [13]	A1/A1p, A9, A11, A12, A13, A16, A17, A18, A19, A21
HRPD IOS with SC/MM in the PCF [3], [4], [13]	A1/A1p, A9, A11, A12, A13, A14, A15, A16, A17, A18, A19, A21
BCMCS IOS [12]	A1/A1p, A9, A11, A12, A13, A14, A15, A16, A17, A18, A19, A21
Femtocell IOS [15]	A1/A1p

3.1 A1/A1p Interface

A1 messages, for both the A1 and A1p interfaces, are used in 1x and HRPD systems. BSMAP messages (refer to Table 3.1-1) are used to perform functions at the MSC or BS while DTAP messages (refer to Table 3.1-2) carry information primarily used by the MS. Note that A1 BSMAP messages are also used on the Fx2 interface as defined in [15].

Table 3.1-1 A1 (BSMAP) Message Types

Type	A1 BSMAP Message Name	Reference
01H	Assignment Request	[1], [2], [3], [4], [8]
02H	Assignment Complete	[1], [2], [3], [4], [8]
03H	Assignment Failure	[8]
04H	Event Notification	[1], [2], [3], [4], [8]
05H	Registration Request	[8]
06H	Event Notification Ack	[1], [2], [3], [4], [8]
07H	BS Authentication Request	[8]
08H	BS Authentication Request Ack	[8]
09H	BS Service Request	[1], [2], [3], [4], [8]
0AH	BS Service Response	[1], [2], [3], [4], [8]
0BH	User Zone Reject	[8]
10H	Handoff Request	[8]
11H	Handoff Required	[8]
12H	Handoff Request Acknowledge	[8]
13H	Handoff Command	[8]
14H	Handoff Complete	[8]
15H	Handoff Commenced	[8]
16H	Handoff Failure	[8]
17H	Handoff Performed	[8]
1AH	Handoff Required Reject	[1], [2], [3], [4], [8]
20H	Clear Command	[8]
21H	Clear Complete	[8]

Table 3.1-1 A1 (BSMAP) Message Types

Type	A1 BSMAP Message Name	Reference
22H	Clear Request	[8]
23H	Radio Measurements for Position Request	[8]
25H	Radio Measurements for Position Response	[8]
30H	Reset	[8]
31H	Reset Acknowledge	[8]
34H	Reset Circuit	[1], [2], [3], [4], [8]
35H	Reset Circuit Acknowledge	[8]
38H	Transcoder Control Request	[8]
39H	Transcoder Control Acknowledge	[8]
40H	Block	[8]
41H	Block Acknowledge	[8]
42H	Unblock	[8]
43H	Unblock Acknowledge	[8]
45H	Authentication Request	[8]
46H	Authentication Response	[8]
48H	Base Station Challenge	[8]
49H	Base Station Challenge Response	[8]
4BH	BS Security Mode Request	[8]
4CH	Security Mode Request	[8]
4DH	Security Mode Response	[8]
52H	Paging Request	[1], [2], [3], [4], [8]
53H	Privacy Mode Command	[8]
55H	Privacy Mode Complete	[8]
56H	Rejection	[1], [2], [3], [4], [8]
57H	Complete Layer 3 Information	[8]
58H	Bearer Update Request	[8]
59H	Bearer Update Response	[8]
5AH	Bearer Update Required	[8]
60H	Feature Notification	[8]
61H	Feature Notification Ack	[8]
65H	ADDS Page	[8]
66H	ADDS Page Ack	[8]
67H	ADDS Transfer	[8]
68H	ADDS Transfer Ack	[8]
69H	Additional Service Notification	[8]
6AH	Status Request	[8]
6BH	Status Response	[8]
6CH	PACA Command	[8]
6DH	PACA Command Ack	[8]

Table 3.1-1 A1 (BSMAP) Message Types

Type	A1 BSMAP Message Name	Reference
6EH	PACA Update	[8]
6FH	PACA Update Ack	[8]
71H	Measurement Request	[15]
72H	Measurement Response	[15]
73H	Femtocell Supplementary Info	[15]

1

Table 3.1-2 A1 (DTAP) Message Types

Type	A1 DTAP Message Name	Reference
02H	Location Updating Accept	[8]
03H	Progress	[8]
04H	Location Updating Reject	[8]
07H	Connect	[8]
08H	Location Updating Request	[8]
0BH	User Zone Reject	[8]
0CH	User Zone Update	[8]
0DH	User Zone Update Request	[8]
10H	Flash with Information	[8]
24H	CM Service Request	[8]
25H	CM Service Request Continuation	[8]
26H	Alert with Information	[8]
27H	Paging Response	[8]
2BH	Parameter Update Confirm	[8]
2CH	Parameter Update Request	[8]
2EH	Service Release	[8]
2FH	Service Release Complete	[8]
45H	Authentication Request	[8]
46H	Authentication Response	[8]
47H	SSD Update Request	[8]
48H	Base Station Challenge	[8]
49H	Base Station Challenge Response	[8]
4AH	SSD Update Response	[8]
4CH	Security Mode Request	[8]
4DH	Security Mode Response	[8]
4EH	Authentication Report	[8]
4FH	Authentication Report Response	[8]
50H	Flash with Information Ack	[8]
53H	ADDS Deliver	[8]
54H	ADDS Deliver Ack	[8]
56H	Rejection	[1], [2], [3], [4], [8]

Table 3.1-2 A1 (DTAP) Message Types

Type	A1 DTAP Message Name	Reference
62H	Additional Service Request	[8]
6AH	Status Request	[8]
6BH	Status Response	[8]
70H	Service Redirection	[8]

1

3.2 A3/A7 Interface

2

3 A3/A7 messages are used only in 1x systems. A3/A7 message types are shown in [9].

3.3 A9 Interface

4

5 A9 messages are used in both 1x and HRPD systems. A9 message types are shown in Table 3.3-1.

6

Table 3.3-1 A9 Message Types

Type	A9 Message Name	Reference
01H	A9-Setup-A8	[1], [2], [3], [4], [10], [13]
02H	A9-Connect-A8	[1], [2], [3], [4], [10], [13]
03H	A9-Disconnect-A8	[1], [2], [3], [4], [10]
04H	A9-Release-A8	[1], [2], [3], [4], [10], [13]
05H	A9-Release-A8 Complete	[1], [2], [3], [4], [10]
06H	A9-BS Service Request	[1], [2], [3], [4], [10]
07H	A9-BS Service Response	[1], [2], [3], [4], [10]
08H	A9-AL Connected	[1], [2], [3], [4], [10]
09H	A9-AL Connected Ack	[1], [2], [3], [4], [10]
0AH	A9-AL Disconnected	[1], [2], [3], [4], [10]
0BH	A9-AL Disconnected Ack	[1], [2], [3], [4], [10]
0CH	A9-Short Data Delivery	[1], [2], [3], [4], [10]
0DH	A9-Short Data Ack	[1], [2], [3], [4], [10]
0EH	A9-Update-A8	[1], [2], [3], [4], [10], [13]
0FH	A9-Update-A8-Ack	[1], [2], [3], [4], [10], [13]
10H	A9-Version Info	[1], [2], [3], [4], [10]
11H	A9-Version Info Ack	[1], [2], [3], [4], [10]
B0H	A9-BC Service Request	[12]
B1H	A9-BC Service Response	[12]
B2H	A9-BC Setup-A8	[12]
B3H	A9-BC Connect-A8	[1], [12]
B4H	A9-BC Disconnect-A8	[12]
B5H	A9-BC Release-A8	[12]
B6H	A9-BC Release-A8 Complete	[12]
B7H	A9-BC Service Initiate Request	[12]
B8H	A9-BC Service Initiate Response	[12]

3.4 A11 Interface

A11 messages are used in both 1x and HRPD systems. A11 message types are shown in Table 3.4-1.

Table 3.4-1 A11 Message Types

Type	A11 Interface Message Name	Reference
01H	A11-Registration Request	[1], [2], [3], [4], [11], [13]
03H	A11-Registration Reply	[1], [2], [3], [4], [11], [13]
14H	A11-Registration Update	[1], [2], [3], [4], [11], [13]
15H	A11-Registration Acknowledge	[1], [2], [3], [4], [11], [13]
16H	A11-Session Update	[1], [2], [3], [4], [11], [13]
17H	A11-Session Update Acknowledge	[1], [2], [3], [4], [11], [13]
18H	A11-Capabilities Info	[11]
19H	A11-Capabilities Info Ack	[11]
B0H	A11-BC Service Request	[12]
B1H	A11-BC Service Response	[12]
B2H	A11-BC Registration Request	[12]
B3H	A11-BC Registration Reply	[12]
B4H	A11-BC Registration Update	[12]
B5H	A11-BC Registration Acknowledge	[12]
B6H	A11-BC Service Initiate Request	[12]
B7H	A11-BC Service Initiate Response	[12]

3.5 A13 Interface

A13 messages are used in HRPD systems. A13 message types are shown in Table 3.5-1.

Table 3.5-1 A13 Message Types

Type	A13 Interface Message Name	Reference
01H	A13-Session Information Request	[1], [2], [3], [4], [13]
02H	A13-Session Information Confirm	[1], [2], [3], [4]
03H	A13-Session Information Reject	[1], [2], [3], [4]
04H	A13-Session Information Response	[1], [2], [3], [4], [13]
05H	A13-Resource Release Request	[1], [2], [3], [4]
06H	A13-Resource Release Response	[1], [2], [3], [4]
07H	A13-Paging Request	[2], [4]
08H	A13-Paging Response	[2], [4]
09H	A13-Keep Alive Request	[2], [4]
0AH	A13-Keep Alive Response	[2], [4]
0BH	A13-Paging Delivered	[2], [4]
0CH	A13-Paging Delivered Ack	[2], [4]
0DH	A13-1x Air Interface Signaling	[2], [4]
0EH	A13-1x Air Interface Signaling Ack	[2], [4]

3.6 A14 Interface

A14 messages are used only in HRPD systems with session control in the PCF. A14 message types are shown in [3], [4] and [13].

3.7 A15 Interface

A15 messages are used only in HRPD systems with session control in the PCF. A15 message types are shown in [3], [4].

3.8 A16 Interface

A16 messages are used in HRPD systems. A16 message types are shown in Table 3.8-1.

Table 3.8-1 A16 Message Types

Type	A16 Interface Message Name	Reference
01H	A16-Session Transfer Request	[1], [2], [3], [4], [13]
02H	A16-Session Transfer Response	[1], [2], [3], [4], [13]
03H	A16-Session Transfer Complete	[1], [2], [3], [4]
04H	A16-Session Release Indication	[1], [2], [3], [4]
05H	A16-Session Release Indication Ack	[1], [2], [3], [4]
06H	A16-Session Transfer Abort	[1], [2], [3], [4]
07H	A16-Session Transfer Abort Ack	[1], [2], [3], [4]
08H	A16-Session Transfer Reject	[1], [2], [3], [4]
09H	A16-FL Signal Tunnel	[2], [4]
0AH	A16-FL Signal Tunnel Ack	[2], [4]
0BH	A16-RL Signal Tunnel	[2], [4]
0CH	A16-RL Signal Tunnel Ack	[2], [4]
0DH	A16-Attributes Update	[2], [4]
0EH	A16-Attributes Update Ack	[2], [4]

3.9 A17, A18, and A19 Interface

A17, A18, and A19 messages are used in HRPD systems. A17, A18, and A19 message types are shown in Table 3.9-1.

Table 3.9-1 A17, A18, and A19 Message Types

Type	A17 Interface Message Name	Reference
01H	A17-Allocate Request	[1], [2], [3], [4]
02H	A17-Allocate Response	[1], [2], [3], [4]
03H	A17-Set Attributes	[1], [2], [3], [4]
04H	A17-Set Attributes Ack	[1], [2], [3], [4]
05H	A17-Modify Request	[1], [2], [3], [4]
06H	A17-Modify Response	[1], [2], [3], [4]
07H	A17-Target Modify Request	[1], [2], [3], [4]
08H	A17-Target Modify Response	[1], [2], [3], [4]

Table 3.9-1 A17, A18, and A19 Message Types

Type	A17 Interface Message Name	Reference
09H	A17-Deallocate Request	[1], [2], [3], [4]
0AH	A17-Deallocate Ack	[1], [2], [3], [4]
0BH	A17-Target Deallocate Request	[1], [2], [3], [4]
0CH	A17-Target Deallocate Ack	[1], [2], [3], [4]
0DH	A17-CC Packet	[1], [2], [3], [4]
10H	A18-FTCH Packet	[1], [2], [3], [4]
11H	A18-RTCH Packet	[1], [2], [3], [4]
12H	A19-Acquisition Status	[1], [2], [3], [4]
13H	A19-Acquisition Status Ack	[1], [2], [3], [4]
14H	A19-Serving RT Changed	[1], [2], [3], [4]
15H	A19-Serving RT Changed Ack	[1], [2], [3], [4]
16H	A19-Forward Desired	[1], [2], [3], [4]
17H	A19-Forward Desired Ack	[1], [2], [3], [4]
18H	A19-Forward Stopped	[1], [2], [3], [4]
19H	A19-Forward Stopped Ack	[1], [2], [3], [4]
1AH	A19-Flush	[1], [2], [3], [4]
1BH	A19-Flush Ack	[1], [2], [3], [4]
1CH	A19-Purge	[1], [2], [3], [4]
1DH	A19-Purge Ack	[1], [2], [3], [4]
1EH	A17-Neighbor Information Request	[1], [2], [3], [4]
1FH	A17-Neighbor Information Notification	[1], [2], [3], [4]
20H	A17-Neighbor Information Notification Ack	[1], [2], [3], [4]
21H	A17-Slave Attach Request	[2], [4]
22H	A17-Slave Attach Response	[2], [4]
23H	A17-Slave Detach Request	[2], [4]
24H	A17-Slave Detach Ack	[2], [4]

1

2 3.10 A21 Interface

3 A21 messages are used in HRPD systems and non-HRPD systems (e.g., E-UTRAN) for interworking
4 with 1x systems. A21 message types are shown in Table 3.10-1.

5

Table 3.10-1 A21 Message Types

Type	A21 Interface Message Name	Reference
01H	A21-1x Air Interface Signaling	[1], [2], [3], [4]
02H	A21-Ack	[1], [2], [3], [4]
03H	A21-1x Parameters	[1], [2], [3], [4]
04H	A21-Event Notification	[1], [2], [3], [4]
05H	A21-1x Parameters Request	[1], [2], [3], [4]
06H	A21-Service Request	[2], [4]

Table 3.10-1 A21 Message Types

Type	A21 Interface Message Name	Reference
07H	A21-Service Response	[2], [4]
08H	A21-Radio Update Request	[1], [2], [3], [4]
09H	A21-Radio Update Response	[1], [2], [3], [4]

1

2 **3.11 A23 Interface**

3 A23 messages are used only in interworking with WiMAX systems. A23 message types are shown in [14].

4

5

4 Information Element Identifiers

This section lists the IEs used in RAN specifications, per interface.

4.1 A1 IEs

A1 IEs are used in 1x and HRPD systems. A1 IEs are shown in Table 4.1-1.

Table 4.1-1 A1 IEs

IEI (Hex)	A1 Element Name	Reference
01H	Circuit Identity Code	[8]
02H	User Zone ID	[8]
03H	Service Option	[8]
04H	Cause	[8]
05H	Cell Identifier	[8]
06H	Priority	[8]
07H	Quality of Service Parameters	[8]
08H	Cause Layer 3	[8]
09H	<i>IS-2000</i> Channel Identity	[8]
0AH	Encryption Information	[8]
0BH	Channel Type	[8]
0CH	CDMA Serving One Way Delay	[8]
0DH	Mobile Identity	[8]
0EH	<i>IS-2000</i> Service Configuration Record	[8]
0FH	<i>IS-2000</i> Non-Negotiable Service Configuration Record	[8]
10H	Extended Handoff Direction Parameters	[8]
11H	<i>IS-2000</i> Mobile Capabilities	[8]
12H	Classmark Information Type 2	[8]
13H	Reserved (This value is used to identify Location Area Identification).	[8]
14H	Source PDSN Address	[8]
15H	MS Information Records	[8]
16H	Hard Handoff Parameters	[8]
17H	Layer 3 Information	[8]
18H	Protocol Type	[8]
19H	Circuit Group	[8]
1AH	Cell Identifier List	[8]
1BH	Response Request	[8]
1CH	(unused – available element identifier values)	n/a
1DH	Radio Environment and Resources	[8]
1EH	Service Option Connection Identifier (SOCI)	[8]
1FH	Registration Type	[8]

Table 4.1-1 A1 IEs

IEI (Hex)	A1 Element Name	Reference
20H	Access Network Identifiers	[8]
21H	RF Channel Identity	[8]
22H	<i>IS-95</i> Channel Identity	[8]
23H	Channel Number	[8]
24H	Circuit Identity Code Extension	[8]
25H	AMPS Hard Handoff Parameters	[8]
26H	Handoff Power Level	[8]
27H	<i>IS-2000</i> Channel Identity 3X	[8]
28H	Authentication Confirmation Parameter (RANDC)	[8]
29H	Downlink Radio Environment	[8]
2AH	Service Option List	[8]
2BH	Downlink Radio Environment List	[8]
2CH	Geographic Location	[8]
2DH	PSMM Count	[8]
2EH	Information Record Requested	[8]
2FH	(unused – available element identifier values)	n/a
30H	Anchor PDSN Address	[8]
31H	Software Version	[8]
32H	SID	[8]
33H	Tag	[8]
34H	Signal	[8]
35H	Slot Cycle Index	[8]
36H	Transcoder Mode	[8]
37H	Band Class	[8]
39H	Source RNC to Target RNC Transparent Container	[8]
3AH	Target RNC to Source RNC Transparent Container	[8]
3BH	Protocol Revision	[8]
3CH	(unused – available element identifier values)	n/a
3DH	ADDS User Part	[8]
3EH	(unused – available element identifier value)	n/a
3FH	Mobile Supported Service Options	[8]
40H	Authentication Parameter COUNT	[8]
41H	Authentication Challenge Parameter	[8]
42H	Authentication Response Parameter	[8]
43H	Reserved (this value is used by the Private Parameters IE)	[8]
44H	Reject Cause	[8]
45H	A2p Bearer Session-Level Parameters	[8]
46H	A2p Bearer Format-Specific Parameters	[8]

Table 4.1-1 A1 IEIs

IEI (Hex)	A1 Element Name	Reference
47H	Integrity Info	[8]
48H	Authentication Vector Info	[8]
49H	AKA Report	[8]
4AH	Authentication Event	[8]
4CH	Enhanced Voice Privacy Request	[8]
4DH	Encryption and Integrity Info	[8]
4EH	PACA Timestamp	[8]
4FH	UIM Authentication Info	[8]
50H	Long Code	[15]
51H	Measurement Response Options	[15]
52H	Measurement Report	[15]
53H	Global RAND Key	[15]
54H	Pilot List	[15]
55H	Nonce	[15]
56H-58H	(unused - available element identifier values)	n/a
59H	Authentication Data	[8]
5AH	Special Service Call Indicator	[8]
5BH	Called Party ASCII Number	[8]
5CH	Reserved (this value is used by the Calling Party BCD Information Element)	[8]
5DH	(unused – available element identifier value)	n/a
5EH	Called Party BCD Number	[8]
5FH	PACA Order	[8]
60H	PACA Reorigination Indicator	[8]
61H	(unused – available element identifier value)	n/a
62H	IS-2000 Cause Value	[8]
63H	(unused – available element identifier value)	n/a
64H	MS Measured Channel Identity	[8]
65H	(unused – available element identifier value)	n/a
66H	(unused – available element identifier value)	n/a
67H	IS-2000 Redirection Record	[8]
68H	Return Cause	[8]
69H	Service Redirection Info	[8]
6AH-6FH	(unused – available element identifier values)	n/a
70H	Packet Session Parameters	[8]
71H	Service Reference Identifier (SR_ID)	[8]
72H	Public Long Code Mask Identifier	[8]
73H	MS Designated Frequency	[8]
74H-7AH	(unused – available element identifier values)	n/a

Table 4.1-1 A1 IEIs

IEI (Hex)	A1 Element Name	Reference
7BH	Page Indicator	[1], [2], [3], [4], [8]
7CH	Anchor P-P Address	[8]
7DH	Mobile Subscription Information	[8]
7EH	Event	[1], [2], [3], [4], [8]
7FH	(reserved - vendor specific use)	n/a
Type 1 Information Elements		
8XH ^a	(unused - available element identifier value)	n/a
9XH ^a	CM Service Type	[8]
Type 2 Information Elements		
A0H	Origination Continuation Indicator	[8]
A1H	Voice Privacy Request	[8]
A2H	Power Down Indicator	[8]
A3H-AFH	(unused - available type 2 element identifier values)	n/a
Additional Type 1 Information Elements		
EXH ^a FXH ^a	(unused - available type 1 element identifier value)	n/a
Information Elements without Identifiers		
none	Message Discrimination	[8]
none	Message Type	n/a
none ^b	Data Link Connection Identifier (DLCI)	[8]
none ^b	Protocol Discriminator	[8]
none ^b	Reserved - Octet	n/a

1

4.2 A3/A7 IEIs

2

3 A3/A7 IEIs are used only in 1x systems. A3/A7 IEIs are shown in [9].

4.3 A9 IEIs

4

5 A9 IEIs are used in both the 1x and HRPD systems. A9 IEIs are shown in Table 4.3-1.

6

Table 4.3-1 A9 IEIs

IEI (Hex)	A9 Element Name	Reference
01H	CON_REF	[10]
02H	User Zone ID	[10]
03H	Service Option	[10]
04H	Cause	[10]
05H	A9 Indicators	[10]

Table 4.3-1 A9 IELs

IEI (Hex)	A9 Element Name	Reference
06H	A9 Cell Identifier	[10]
07H	Quality of Service Parameters	[10]
08H	A8 Traffic ID	[10]
09H	Data Count	[10]
0AH	Active Connection Time in Seconds	[10]
0BH	SR_ID	[10]
0CH	A9 PDSN Code	[10]
0DH	Mobile Identity	[10]
0EH	IS-2000 Service Configuration Record	[10]
0FH	RN-PDIT	[10]
13H	Correlation ID	[10]
14H	PDSN Address	[10]
20H	Access Network Identifiers	[10]
30H	Anchor PDSN Address	[10]
31H	Software Version	[10]
3DH	ADDS User Part	[10]
3FH	Call Connection Reference	[10]
40H	Anchor P-P Address	[10]
41H	Service Instance Info	[10]
88H	Sector ID	[3], [4]
89H	Security Layer Packet	[3], [4]
8AH	Session State Information Record	[3], [4]
8BH	HRPD A9 Indicators	[3], [4]
8CH	System Time	[3], [4]
8DH	Extended Session State Information Record	[3], [4]
8EH	Forward QoS Information	[1], [2], [3], [4]
8FH	Reverse QoS Information	[1], [2], [3], [4]
90H	Subscriber QoS Profile	[1], [2], [3], [4]
91H	Flow ID	[1], [2], [3], [4]
92H	Additional A8 Traffic ID	[1], [2], [3], [4]
93H	ROHC Configuration Parameters	[1], [2], [3], [4]
94H	Forward QoS Update Information	[1], [2], [3], [4]
95H	Reverse QoS Update Information	[1], [2], [3], [4]
96H	Assigning SC IP Address	[4]
97H	Timers	[4]
98H	eHRPD A9 Indicators	[2], [4], [13]
99H	EPS Information	[13]
9AH	HSGW Information	[2], [4], [13]

Table 4.3-1 A9 IEs

IEI (Hex)	A9 Element Name	Reference
9BH	Forward Flow Priority Update Information	[2], [4], [13]
9CH	Reverse Flow Priority Update Information	[2], [4], [13]
B0H	A8 BC Traffic ID	[12]
B1H	BCMCS Information List	[12]
B2H	BCMCS Flow and Registration Information	[12]
B3H	BCMCS Registration Result	[12]
B4H	BCMCS Flow ID	[12]
B5H	HRPD Subnet	[12]
B6H	BSID	[12]
B7H	Enhanced BCMCS Information List	[12]

1

4.4 A11 IEs

2

A11 IEs are used in both the 1x and HRPD systems. A11 IEs are shown in Table 4.4-1.

3

4

Table 4.4-1 A11 IEs

IEI (Hex)	A11 Element Name	Reference
None	A11 Message Type	[11]
None	Care-of-Address	[11]
None	Code	[11]
None	Flags	[11]
None	Home Address	[11]
None	Home Agent	[11]
None	Identification	[11]
None	Lifetime	[11]
None	Status	[11]
None	Reason	[12]
20H	Mobile-Home Authentication Extension	[11]
26H	Critical Vendor/Organization Specific Extension	[11]
27H	Session Specific Extension	[11]
28H	Registration Update Authentication Extension	[11]
86H	Normal Vendor/Organization Specific Extension	[11]
B0H	BCMCS Session Extension	[12]

5

4.5 A13 IEs

A13 IEs are used in HRPD systems. A13 IEs are shown in Table 4.5-1.

Table 4.5-1 A13 IEs

IEI (Hex)	A13 Element Name	Reference
01H	UATI 128	[1], [2], [3], [4]
02H	Security Layer Packet	[1], [2], [3], [4]
03H	Sector ID	[1], [2], [3], [4]
04H	Cause	[1], [2], [3], [4]
05H	Mobile Identity (MN ID)	[1], [2], [3], [4]
06H	PDSN IP Address	[1], [2], [3], [4]
07H	Access Network Identifiers	[1], [2], [3], [4]
08H	Session State Information Record	[1], [2], [3], [4]
09H	Extended Session State Information Record	[1], [2], [3], [4]
0AH	Forward QoS Information	[1], [2], [3], [4]
0BH	Reverse QoS Information	[1], [2], [3], [4]
0CH	Subscriber QoS Profile	[1], [2], [3], [4]
0DH	Hardware ID	[1], [2], [3], [4]
0EH	Forward QoS Update Information	[1], [2], [3], [4]
0FH	Reverse QoS Update Information	[1], [2], [3], [4]
10H	AT-ID	[2], [4]
11H	Correlation ID	[2], [4]
12H	Paging Control Information	[2], [4]
13H	Paging Cause	[2], [4]
14H	AT Designated Frequency	[2], [4]
15H	A13 Vendor-Specific Information	[2], [4]
16H	Adds User Part	[2], [4]
17H	A13 1x LAC PDU	[2], [4]
18H	A13 1x Message Transmission Control	[2], [4]
19H	Data Transfer	[2], [4]
1AH	Forward Flow Priority Update Information	[2], [4], [13]
1BH	Reverse Flow Priority Update Information	[2], [4], [13]
20H	Source HSGW H1 IPv4 Address	[13]
21H	A13 eHRPD Indicators	[13]

4.6 A14 IEIs

A14 IEIs are used in HRPD and eHRPD systems with session control in the PCF. A14 IEIs are shown in Table 4.6-1.

Table 4.6-1 A14 IEIs

IEI (Hex)	A14 Element Name	Reference
04H	Cause	[3], [4]
13H	Correlation ID	[3], [4]
20H	Access Network Identifiers	[3], [4]
80H	ATI	[3], [4]
81H	Sector ID List	[3], [4]
82H	A14 Indicators	[3], [4]
83H	Message Sequence	[3], [4]
84H	Upper Old UATI Length	[3], [4]
85H	Upper Old UATI	[3], [4]
86H	UATI Subnet Mask	[3], [4]
87H	A20 Traffic ID	[3], [4]
88H	Sector ID	[3], [4]
89H	Security Layer Packet	[3], [4]
8AH	Session State Information Record	[3], [4]
8BH	HRPD A9 Indicators	[3], [4]
8CH	System Time	[3], [4]
8DH	UATI Color Code	[3], [4]
8EH	AT Designated Frequency	[3], [4]
8FH	Extended Session State Information Record	[3], [4]
90H	Forward QoS Information	[3], [4]
91H	Reverse QoS Information	[3], [4]
92H	Subscriber QoS Profile	[3], [4]
93H	A14 1x LAC PDU	[3], [4]
94H	Prior Information	[3], [4]
95H	Forward QoS Update Information	[3], [4]
96H	Reverse QoS Update Information	[3], [4]
97H	LCM UATI	[3], [4]
98H	Authentication Challenge Parameter	[3], [4]
99H	1x Message Transmission Control	[3], [4]
9AH	Pilot List	[3], [4]
9BH	A14 1x Parameters	[4]
9CH	Paging Control Information	[4]
9DH	eHRPD A14 Indicators	[13]

4.7 A15 IEIs

A15 IEIs are used only in HRPD systems with session control in the PCF. A15 IEIs are shown in [3], [4].

4.8 A16 IEIs

A16 IEIs are used in HRPD systems. A16 IEIs are shown in Table 4.8-1.

Table 4.8-1 A16 IEIs

IEI (Hex)	A16 Element Name	Reference
01H	Mobile Identity (MN ID)	[1], [2], [3], [4]
02H	Access Network Identifiers	[1], [2], [3], [4]
03H	Session State Information Record	[1], [2], [3], [4]
04H	Proposed Session State Information Record	[1], [2], [3], [4]
05H	Extended Session State Information Record	[1], [2], [3], [4]
06H	Source PDSN Address	[1], [2], [3], [4]
07H-08H	Reserved	n/a
09H	Encapsulated Message	[1], [2], [3], [4]
0AH	Session Transfer Information	[1], [2], [3], [4]
0BH	Session Transfer Abort Cause	[1], [2], [3], [4]
0CH	AT-ID	[1], [2], [3], [4]
0DH	ConfirmedUATI	[1], [2], [3], [4]
0EH	AssignedUATI	[1], [2], [3], [4]
0FH	LCM UATI	[1], [2], [3], [4]
10H	SLP-D Parameters	[1], [2], [3], [4]
11H	SLP-F Parameters	[1], [2], [3], [4]
12H	Forward QoS Information	[1], [2], [3], [4]
13H	Reverse QoS Information	[1], [2], [3], [4]
14H	Subscriber QoS Profile	[1], [2], [3], [4]
15H	Forward QoS Update Information	[1], [2], [3], [4]
16H	Reverse QoS Update Information	[1], [2], [3], [4]
17H	Session Transfer Reject Cause	[1], [2], [3], [4]
18H	Correlation ID	[1], [2], [3], [4]
19H	Session Transfer Complete Parameters	[2], [4]
1AH	Sequence Number	[2], [4]
1BH	Fixed Rate Mode	[2], [4]
1CH	Serving Sector Information	[2], [4]
1DH	FL Signal Tunnel Parameter	[2], [4]
1EH	Sector Endpoint Information	[2], [4]
1FH	SLP Reset Message SEQ info	[2], [4]
20H	Assigning SC IP Address	[2], [4]
21H	Timers	[2], [4]

Table 4.8-1 A16 IEIs

IEI (Hex)	A16 Element Name	Reference
22H	RTD Information	[2], [4]
23H	Serving Sector ID	[1], [2], [3], [4]
24H	Target Sector ID	[1], [2], [3], [4]
25H	Source HSGW H1 IPv4 Address	[13]
26H	Forward Flow Priority Update Information	[2], [4], [13]
27H	Reverse Flow Priority Update Information	[2], [4], [13]
28H	PDN Information	[13]
29H	Forwarding Tunnel Parameter	[13]
2AH	HRPDOpenLoopParameters	[13]

1

4.9 A17, A18 and A19 IEIs

2

3 A17, A18 and A19 IEIs are used in HRPD systems. The A17, A18 and A19 interfaces share a common
4 set of IEIs and are identified by the first interface listed, A17. A17 IEIs are shown in Table 4.9-1.

5

Table 4.9-1 A17 IEIs

IEI (Hex)	A17 Element Name	Reference
02H	Current Session State Information Record	[1], [2], [3], [4]
03H	Proposed Session State Information Record	[1], [2], [3], [4]
04H	Alternative Session State Information Record	[1], [2], [3], [4]
08H	Sector Information	[1], [2], [3], [4]
0BH	Correlation ID	[1], [2], [3], [4]
0CH	AT Acquired Flag	[1], [2], [3], [4]
0DH	RTCH Power Control Setpoint	[1], [2], [3], [4]
0EH	Deallocation Timer	[1], [2], [3], [4]
0FH	Power Ramp-Up Bias	[1], [2], [3], [4]
10H	Queue ID Information	[1], [2], [3], [4]
11H	FTCH Packet Served Status	[1], [2], [3], [4]
12H	AT Acquisition Status	[1], [2], [3], [4]
13H	CC Packet Control Information	[1], [2], [3], [4]
14H	Air-Interface Signaling Header	[1], [2], [3], [4]
15H	RL Application Layer Packet	[1], [2], [3], [4]
16H	FL Application Layer Packet	[1], [2], [3], [4]
18H	RTCH Packet Control Information	[1], [2], [3], [4]
19H	Last Packet ID Served	[1], [2], [3], [4]
1AH	Rapid Commit	[1], [2], [3], [4]
1BH	CRC Pass Fail	[1], [2], [3], [4]
1CH	AN A17 IPv4 Address	[1], [2], [3], [4]

Table 4.9-1 A17 IEIs

IEI (Hex)	A17 Element Name	Reference
1DH	Neighbor Information	[1], [2], [3], [4]
1FH	Leg Number	[1], [2], [3], [4]
21H	AT-ID	[1], [2], [3], [4]
22H	AN Leg Information	[1], [2], [3], [4]
23H	Leg-Sector Association	[1], [2], [3], [4]
24H	RT Leg Information	[1], [2], [3], [4]
25H	Requested Sector Information	[1], [2], [3], [4]
26H	A17 Cause	[1], [2], [3], [4]

1

4.10 A21 IEIs

2

A21 IEIs are used in HRPD and non-HRPD (e.g. E-UTRAN) systems for interworking with 1x systems.

3

A21 IEIs are shown in Table 4.10-1.

4

5

Table 4.10-1 A21 IEIs

IEI (Hex)	A21 Element Name	Reference
01H	1x LAC PDU	[1], [2], [3], [4]
02H	A21 1x Parameters	[1], [2], [3], [4]
03H	Pilot List	[1], [2], [3], [4]
04H	Correlation ID	[1], [2], [3], [4]
05H	Mobile Identity (MN ID)	[1], [2], [3], [4]
06H	Authentication Challenge Parameter (RAND)	[1], [2], [3], [4]
07H	A21 1x Message Transmission Control	[1], [2], [3], [4]
08H	A21 Cause	[1], [2], [3], [4]
09H	A21 Event	[1], [2], [3], [4]
0AH	Service Option	[2], [4]
0BH	A21 Mobile Subscription Information	[2], [4]
0CH	GCSNA Status	[2], [4]
0DH	Reference Cell ID	[2], [4]
30H-3FH	Reserved range of IEIs for S102	[2], [4]
C0H	GCSNA PDU	[2], [4]

6

4.11 A23 IEIs

7

There are currently no IEIs defined for the A23 interface.

8

9

10

1
2
3

(This page intentionally left blank)

5 Code, Cause, and Other Values

This section lists the code, cause and other shared values used in RAN specifications, per interface.

5.1 A1 Cause Values

A1 cause values are shown in Table 5.1-1.

Table 5.1-1 A1 Cause Values

Hex Value	Cause	Reference
Normal Event Class (000 xxxx and 001 xxxx)		
00	Radio interface message failure	[8]
01	Radio interface failure	[8]
02	Uplink quality	[8]
03	Uplink strength	[8]
04	Downlink quality	[8]
05	Downlink strength	[8]
06	Distance	[8]
07	OAM&P intervention	[8]
08	MS busy	[8]
09	Call processing	[8]
0A	Reversion to old channel	[8]
0B	Handoff successful	[8]
0C	No response from MS	[8]
0D	Timer expired	[8]
0E	Better cell (power budget)	[8]
0F	Interference	[8]
10	Packet call going dormant	[8]
11	Service option not available	[8]
15	Short data burst authentication failure	[8]
17	Time critical relocation/handoff	[8]
18	Network optimization	[8]
19	Power down from dormant state	[8]
1A	Authentication failure	[8]
1B	Inter-BS soft handoff drop target	[8]
1D	Intra-BS soft handoff drop target	[8]
1E	Autonomous Registration by the Network	[8]
1F	1x-service rejected	[1], [2], [3], [4]
Resource Unavailable Class (010 xxxx)		
20	Equipment failure	[8]
21	No radio resource available	[8]
22	Requested terrestrial resource unavailable	[8]
23	A2p RTP Payload Type not available	[8]
24	A2p Bearer Format Address Type not available	[8]
25	BS not equipped	[8]
26	MS not equipped (or incapable)	[8]
27	2G only sector	[8]
28	2G only carrier	[8]
29	PACA call queued	[8]
2A	Handoff Blocked	[8]
2B	Alternate signaling type reject	[8]

Table 5.1-1 A1 Cause Values

Hex Value	Cause	Reference
2C	A2p Resource not available	[8]
2D	PACA queue overflow	[8]
2E	PACA cancel request rejected	[8]
Service or Option Not Available Class (011 xxxx)		
30	Requested transcoding/rate adaptation unavailable	[8]
31	Lower priority radio resources not available	[8]
32	PCF resources are not available	[1], [2]
33	TFO control request failed	[8]
34	MS rejected order	[8]
Service or Option Not Implemented Class (100 xxxx)		
45	PDS-related capability not available or not supported)	[8]
Invalid Message Class (101 xxxx)		
50	Terrestrial circuit already allocated	[8]
Protocol Error (110 xxxx)		
60	Protocol error between BS and MSC	[8]
Interworking (111 xxxx)		
70	Measurement successful	[15]
71	ADDS message too long for delivery on the paging channel	[8]
72	MS not detected	[15]
73	MS not allowed	[15]
74	BS busy	[15]
75	Terrestrial resources not available	[15]
76	Measurement procedure time-out	[15]
77	PPP session closed by the MS	[8]
78	Do not notify MS	[8]
79	PCF (or PDSN) resources are not available	[8]
7B	Concurrent authentication	[8]
7F	Handoff procedure time-out	[8]
All other values are reserved		

1

2 **5.2 A3/A7 Cause Values**

3 A3/A7 cause values are used only in 1x systems. A3/A7 cause values are shown in [9].

4 **5.3 A9 Cause Values and Indicators**

5 A9 cause values are shown in Table 5.3-1 and A9 indicators are shown in Table 5.3-2.

6

Table 5.3-1 A9 Cause Values

Hex Value	Cause	Reference
Normal Event Class (000 xxxx and 001 xxxx)		
01	Partial connection release	[1], [2], [3], [4]
02	Multi-connection required	[1], [2], [3], [4]
03	Partial connection establishment	[3], [4]
05	Program end	[12]
06	Too few users	[12]

Table 5.3-1 A9 Cause Values

Hex Value	Cause	Reference
07	OAM&P intervention	[10]
08	MS busy	[10]
0B	Handoff successful	[10]
0F	Packet data session release	[10]
10	Packet call going dormant (HRPD connection release)	[10]
11	Service option not available	[10]
13	Successful operation	[10], [12]
14	Normal call release (HRPD session release)	[10], [12]
16	Initiate re-activation of packet data call	[10]
17	SDB successfully delivered	[10]
18	SDB couldn't be delivered	[10]
19	Power down from dormant state	[10]
1A	Authentication failure	[10]
1B	Capability update	[10]
1C	Update Accounting: late traffic channel setup	[10]
1D	Hard handoff failure	[10]
1E	Update Accounting: parameter change	[10]
1F	Air link lost	[1], [2], [3], [4]
2B	BS resources are not available	[1], [2], [3], [4]
2C	Partial QoS update	[3], [4]
2E	QoS update	[3], [4]
2F	Flow priority update	[2], [4] [13]
Resource Unavailable Class (010 xxxx)		
20	Equipment failure	[10], [12]
23	Authentication required	[1], [2], [3], [4]
24	Session unreachable	[1], [2], [3], [4]
Service or Option Not Available Class (011 xxxx)		
32	PCF resources are not available	[1], [2], [3], [4], [10], [12]
36	Session parameter/option not supported at BS	[10], [12]
Service or Option Not Implemented Class (100 xxxx)		
Invalid Message Class (101 xxxx)		
Protocol Error (110 xxxx)		
60	State mismatch	[1], [2], [3], [4]
61	PMK not requested	[2], [4], [13]
Interworking (111 xxxx)		
79	PDSN resources are not available	[10], [12]
7A	Data ready to send	[10]
7B	Session parameter update	[10]
All other values are reserved		

1
2

Octet	Bit	A9 Indicator	Reference
3	0	Handoff Indicator	[1], [2], [3], [4], [10], [12]
3	1	Data Ready Indicator	[1], [2], [3], [4], [10], [12]
3	2	Emergency Services	[2], [4]
3	3	CCPD Mode	[10]
3	4	SDB/DoS Supported	[1], [2], [3], [4], [10], [12]
3	5	GRE Segment Supported	[1], [2], [3], [4], [10], [12]
3	6	Packet Boundary Supported	[1], [2], [3], [4], [10], [12]
3	7	QoS Mode	[1], [2], [3], [4]
4	0	Buffer Transfer	[2]
All other values are reserved			

1

5.4 A11 Code, PDSN Code, and Status Values

2

3 A11 Code values are shown in Table 5.4-1, Status Values are shown in Table 5.4-2, Application Types
4 are shown in Table 5.4-3 and PDSN Code Values are shown in Table 5.4-4.

5

Table 5.4-1 A11 Code Values

Hex Value	Code	Reference
00H	Registration Accepted	[1], [2], [3], [4], [11], [12]
02H	Registration Accepted, but partial connection establishment	[2], [4]
09H	Reserved	[11]
80H	Registration Denied – reason unspecified	[1], [2], [3], [4], [11], [12]
81H	Registration Denied – administratively prohibited	[1], [2], [3], [4], [11], [12]
82H	Registration Denied – insufficient resources	[1], [2], [3], [4], [11], [12]
83H	Registration Denied – PCF failed authentication	[1], [2], [3], [4], [11], [12]
85H	Registration Denied – identification mismatch	[1], [2], [3], [4], [11], [12]
86H	Registration Denied – poorly formed request	[1], [2], [3], [4], [11], [12]
88H	Registration Denied – unknown PDSN address	[1], [2], [3], [4], [11], [12]
89H	Registration Denied – requested reverse tunnel unavailable	[1], [2], [3], [4], [11], [12]
8AH	Registration Denied – reverse tunnel is mandatory and ‘T’ bit not set	[1], [2], [3], [4], [11], [12]
8BH	Registration Denied – service option not supported	[1], [2], [3], [4]
8CH	Registration Denied – no CID available	[1], [2], [3], [4]
8DH	Registration Denied – unsupported Vendor ID or unable to interpret Application Type or Application Sub Type in the CVSE sent by the PCF to the BSN	[1], [2], [3], [4], [11], [12]
8EH	Registration Denied - nonexistent A10 or IP flow	[1], [2], [3], [4]
B0H	Registration Denied - BSN session info unavailable	[12]
B1H	Session information accepted	[12]
B2H	Session parameter/option not supported at BS	[12]
B3H	Rejected – failed authentication	[12]

Table 5.4-1 A11 Code Values

Hex Value	Code	Reference
B4H	Rejected – identification mismatch	[12]
All other values are reserved		

1
2**Table 5.4-2 A11 Status Values**

Hex Value	A11 Status	Reference
00H	Update Accepted	[1], [2], [3], [4], [11], [12]
01H	Partial QoS updated	[2], [4]
80H	Update Denied – reason unspecified	[1], [2], [3], [4], [11], [12]
83H	Update Denied – sending node failed authentication	[1], [2], [3], [4], [11], [12]
85H	Update Denied – identification mismatch	[1], [2], [3], [4], [11], [12]
86H	Update Denied – poorly formed registration update	[1], [2], [3], [4], [11], [12]
C9H	Update Denied – session parameters not updated	[1], [2], [3], [4], [11]
CAH	Update Denied – PMK not requested	[2], [4], [13]
FDH	Update Denied – QoS profileID not supported	[1], [2], [3], [4]
FEH	Update Denied – insufficient resources	[1], [2], [3], [4]
FFH	Update Denied – handoff in progress	[1], [2], [3], [4]
All other values are reserved		

3
4**Table 5.4-3 A11 NVSE Application Types**

Application Type		Application Sub Type		Reference
Name	Value	Name	Value	
Accounting	01H	RADIUS	01H	[11]
		DIAMETER	02H	[11]
Mobility Event Indicator	02H	Mobility	01H	[11]
Data Available Indicator	03H	Data Ready to Send	01H	[11]
Access Network Identifiers (ANID)	04H	ANID	01H	[11]
PDSN Identifier	05H	Anchor P-P Address	01H	[11]
Indicators	06H	All Dormant Indicator	01H	[11]
		eHRPD Mode	02H	[13]
		eHRPD Indicators	03H	[2], [4], [13]
PDSN Code	07H	PDSN CODE	01H	[11]
Session Parameter	08H	RN-PDIT	01H	[11]
		Always-On	02H	[11]
		QoS Mode	03H	[1], [2], [3], [4]
Service Option	09H	Service Option Value	01H	[11]

PDSN Enabled Features	0AH	Flow Control Enabled	01H	[11]
		Packet Boundary Enabled	02H	[11]
		GRE Segmentation Enabled	03H	[1], [2], [3], [4]
PCF Enabled Features	0BH	Short Data Indication Supported	01H	[11]
		GRE Segmentation Enabled	02H	[11]
Additional Session Information	0CH	Additional Session Information	01H	[1], [2], [3], [4]
QoS Information	0DH	Forward QoS Information	01H	[1], [2], [3], [4]
		Reverse QoS Information	02H	[1], [2], [3], [4]
		Subscriber QoS Profile	03H	[1], [2], [3], [4]
		Forward Flow Priority Update Information	04H	[2], [4], [13]
		Reverse Flow Priority Update Information	05H	[2], [4], [13]
		Forward QoS Update Information	FEH	[1], [2], [3], [4]
		Reverse QoS Update Information	FFH	[1], [2], [3], [4]
Header Compression Information	0EH	ROHC Configuration Parameters	01H	[1], [2], [3], [4]
Information	0FH	Cause code	01H	[2], [4]
		HSGW H1 Address Information	02H	[13]
		EPS Information	03H	[13]
		Additional HSGW Information	04H	[2], [4], [13]
HRPD Indicators	10H	Emergency Services	01H	[2], [4]

1
2**Table 5.4-4 A11 PDSN Code Values**

Hex Value	PDSN Code	Reference
C1H	Connection Release - reason unspecified	[1], [2], [3], [4], [11]
C2H	Connection Release - PPP time-out	[2], [4], [11]
C3H	Connection Release - registration time-out	[1], [2], [3], [4], [11]
C4H	Connection Release - PDSN error	[2], [4], [11]
C5H	Connection Release - inter-PCF handoff	[1], [2], [3], [4], [11]
C6H	Connection Release - inter-PDSN handoff	[1], [2], [3], [4], [11]
C7H	Connection Release - PDSN OAM&P intervention	[1], [2], [3], [4], [11]
C8H	Connection Release - accounting error	[1], [2], [3], [4], [11]
CAH	Connection Release - user (NAI) failed authentication	[11]
CBH	PDSN reset	[11]
All other values are reserved		

3

5.5 A13 Cause Values

A13 cause values are shown in Table 5.5-1.

Table 5.5-1 A13 Cause Values

Hex Value	Cause Value Meaning	Reference
01H	Protocol subtype not recognized	[1], [2], [3], [4]
02H	Protocol subtype attribute(s) not recognized	[1], [2], [3], [4]
03H	Protocol subtype attribute(s) missing	[1], [2], [3], [4]
04H	Requested session not found	[1], [2], [3], [4]
05H	Requested session not authentic	[1], [2], [3], [4]
06H	Requested prior session released	[1], [2], [3], [4]
07H	Requested prior session not found	[1], [2], [3], [4]
08H	Requested prior session not authentic	[1], [2], [3], [4]
09H	Requested session is not in handoff	[2], [4]
All other values are reserved		

5.6 A14 Cause Values

A14 cause values are used only in HRPD systems with session control in the PCF. A14 cause values are shown in [3], [4].

5.7 A15 Code and Cause Values

There are currently no code or cause values defined for the A15 interface.

5.8 A16 Cause Values

A16 session transfer causes are shown in Table 5.8-1 and Table 5.8-2.

Table 5.8-1 A16 Session Transfer Abort Cause Values

Hex Values	Abort Cause Value Meaning	Reference
00	No reason specified	[1], [2], [3], [4]
01	Timeout	[1], [2], [3], [4]
02	Connection Release	[1], [2], [3], [4]
03	AT lost	[1], [2], [3], [4]
All other values are reserved		

Table 5.8-2 A16 Session Transfer Reject Cause Values

Hex Values	Reject Cause Value Meaning	Reference
00	No reason specified	[1], [2], [3], [4]
01	The target AN cannot support some Session State Information Records and/or Extended Session State Information Records	[1], [2], [3], [4]

Table 5.8-2 A16 Session Transfer Reject Cause Values

Hex Values	Reject Cause Value Meaning	Reference
02	Insufficient radio resources in the target AN to support the session	[1], [2], [3], [4]
03	Insufficient network resources in the target AN to support the session	[1], [2], [3], [4]
04	Equipment failures	[1], [2], [3], [4]
05	Make before break is not supported	[2], [4]
All other values are reserved		

1

5.9 A17 Cause Values

2

3 A17 cause values are shown in Table 5.9-1.

3

Table 5.9-1 A17 Cause Values

Hex Value	Cause Value Meaning	Reference
00H	Successful operation	[1], [2], [3], [4]
01H	Counter proposal	[1], [2], [3], [4]
02H	Reject – No reason specified	[1], [2], [3], [4]
03H	Reject – Radio resource unavailable	[1], [2], [3], [4]
04H	Reject – Network resource unavailable	[1], [2], [3], [4]
05H	No reason specified	[1], [2], [3], [4]
06H	Air link lost	[1], [2], [3], [4]
07H	Equipment failure	[1], [2], [3], [4]
All other values are reserved		

4

5.10 A21 Cause, Event and GCSNA Status Values

5

6 A21 cause values are shown in Table 5.10-1, A21 event values are shown in Table 5.10-2 and GCSNA
7 status values are shown in Table 5.10-3.

8

Table 5.10-1 A21 Cause Values

Hex Value	A21 Cause Value Meaning	Reference
00H	Unknown mobile	[1], [2], [3], [4]
01H	Unknown cell identifier(s)	[1], [2], [3], [4]
02H	Tunneling of 1x messages not available	[1], [2], [3], [4]
03H	Resources not available	[1], [2], [3], [4]
04H	A21 context for this MS/AT may be released	[1], [2], [3], [4]
05H	Airlink lost	[1], [2], [3], [4]
06H	Abort Handoff from HRPD to 1x	[1], [2], [3], [4]
07H	Unspecified	[1], [2], [3], [4]
08H	Rejection	[2], [4]
09H	Already Paging	[2], [4]

Table 5.10-1 A21 Cause Values

Hex Value	A21 Cause Value Meaning	Reference
0AH	Reserved for backwards compatibility	[2], [4]
All other values are reserved		

1

Table 5.10-2 A21 Event Values

Hex Value	Event Meaning	Reference
00H	MS/AT present in 1x	[1], [2], [3], [4]
01H	MS/AT present in HRPD/Cancel Handoff	[1], [2], [3], [4]
02H	1x Power Down	[1], [2], [3], [4]
03H	HRPD Power Down/Connection Closed	[1], [2], [3], [4]
04H	Handoff Reject ²	[1], [2], [3], [4]
05H	1x Registration	[2], [4]
06H	Transmission of All 1x LAC Encapsulated PDUs Disabled	[2], [4]
07H	Transmission of 1x LAC Encapsulated PDU(s) Enabled	[2], [4]
08H	MS/AT no longer present in this AN/PCF	[2], [4]
09H	MS/AT no longer present in this 1xBS	[2], [4]
0AH	MS/AT Not Acquired	[1], [2], [3], [4]
0BH	Redirection	[1], [2], [3], [4]
All other values are reserved		

2

Table 5.10-3 GCSNA Status Values

Hex Value	Status Meaning	Reference
01H	Handoff successful	[2], [4]
02H	Handoff failure	[2], [4]
All other values are reserved		

3

5.11 A23 Code and Cause Values

4

There are currently no code or cause values defined for the A23 interface.

5

6

7

² This Event meaning was formerly called “MS/AT Service Reject”.

1
2
3

(This page intentionally left blank)